

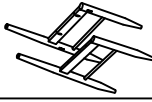









ASSEMBLY INSTRUCTIONS

MODEL : LW 2404

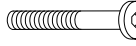
ITEM	PART NAME	QTY
1	Back Rest 	1 PC
2	Chair Leg R&L 	2 PCS
3	Front Apron 	1 PC
4	Back Apron 	1 PC
5	Back Support 	1 PC
6	Seat Cushion 	1 PC

ITEM	HARDWARE LIST	DESCRIPTION	QTY
A	JCBC M6 x 45mm		4 PCS
B	JCBC M6 x 35mm		2 PCS
C	Spring Washer M6 x 13		6 PCS
D	Wood Dowel M8 x 30		4 PCS
E	CSK Screw M4 x 32		7 PCS
F	Allen Key		1 PC

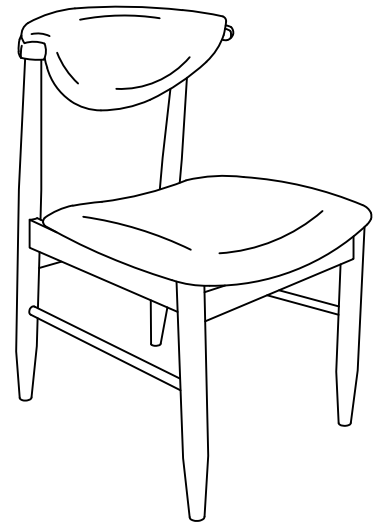

STEP 1

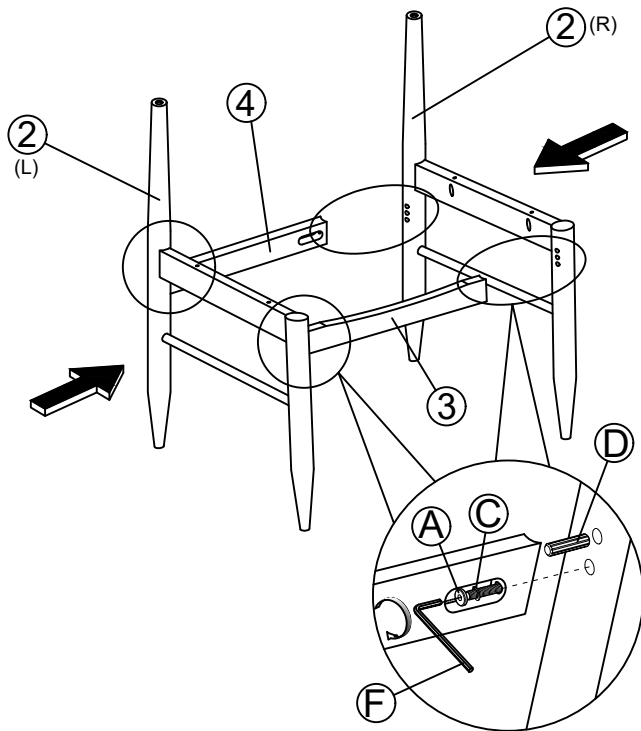

STEP 2

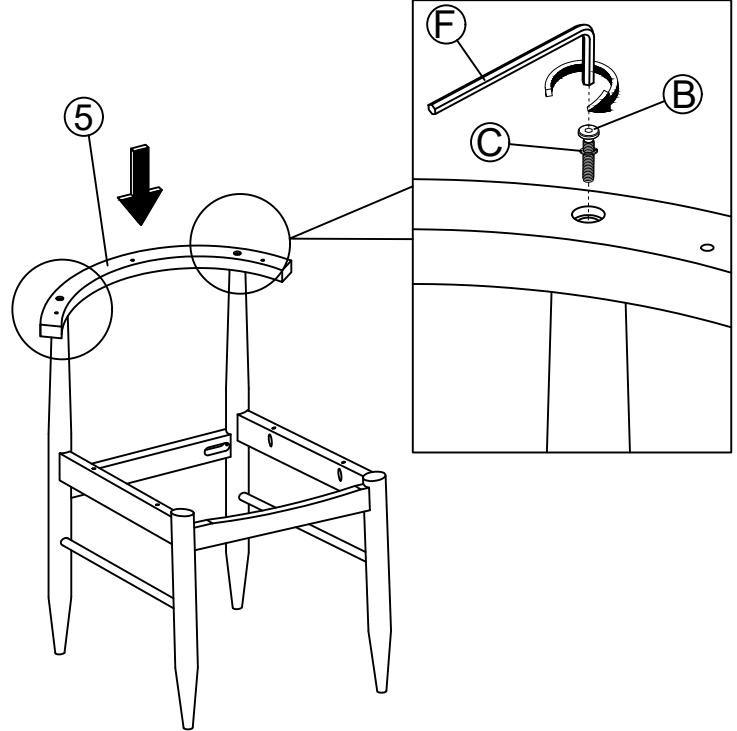

STEP 3

