

ASSEMBLY INSTRUCTION

Montageanleitung
Instructions De Montage
Istruzioni Per L'assemblaggio
Instrucciones De Montaje
組立説明書
安装说明书



HELPFUL HINTS

⚠ BEFORE YOU START

- Inspect product packaging to ensure the appearance is good.
- Read the assembly instruction carefully and follow it step by step.
- To avoid any scratching, putting a soft blanket on the floor is suggested.
- Identify, sort and count all the parts with tags.
- Find out installation position according to the drawing and install it in correct steps.



OTHER

- 1-2 people are required for assembly
- Estimated assembly time 3-5 minutes

⚠ CAUTION

- Be cautious when using a power drill or power screwdriver.
- Please be aware to slow down and stop when screw is nearly tight.
- Do Not use any harsh chemicals or abrasive cleaners for this item.
- Push, pull or drag this item carefully.

ASTUCES UTILES

⚠ AVANT DE COMMENCER

- Inspectez l'emballage du produit pour vous assurer que l'apparence est bonne.
- Lisez attentivement les instructions de montage et suivez-les étape par étape.
- Pour éviter toute rayure, posez une couverture douce sur le sol est suggéré.
- Identifiez, trie et comptez toutes les pièces avec des étiquettes.
- Trouver la position d'installation selon le dessin et l'installer dans les étapes correctes.



AUTRE

- Für die Montage werden 1-2 Personen benötigt
- Geschätzte Montagezeit 3-5 Minuten

⚠ AVERTIR

- Soyez prudent lorsque vous utilisez une perceuse électrique ou un tournevis électrique.
- Veuillez être conscient de ralentir et d'arrêter lorsque la vis est presque serrée.
- N'utilisez pas de produits chimiques corrosifs ou de nettoyeurs abrasifs pour cet article.
- Poussez, tirez ou tirez cet article avec précaution.

CONSEJOS ÚTILES

⚠ ANTES DE EMPEZAR

- Inspeccione el paquete del producto para asegurarse de que la apariencia es buena.
- Lea atentamente las instrucciones de montaje y sígalas paso a paso.
- Para evitar rayas, se sugiere poner una manta suave en el suelo.
- Identifique, clasifique y enumere todas las piezas con etiquetas.
- Averigüe la posición de instalación según el dibujo e instálela en los pasos correctos.



OTROS

- 1 à 2 personnes sont nécessaires pour l'assemblage
- Temps d'assemblage estimé 3 à 5 minutes

⚠ PRECAUCIÓN

- Tenga cuidado al utilizar un taladro eléctrico o un destornillador eléctrico.
- Tenga en cuenta que debe hacerlo más despacio y detenerse cuando el tornillo esté casi apretado.
- No utilice productos químicos agresivos ni limpiadores abrasivos para este artículo.
- Empuje, tire o arrastre este elemento con cuidado.

SUGGERIMENTI UTILI

⚠ PRIMA DI INIZIARE

- Controllare la confezione del prodotto per assicurarsi che sia in buono stato.
- Leggere con attenzione le istruzioni per l'assemblaggio e seguirle passo dopo passo.
- Per evitare graffi al pavimento, suggeriamo di stenderci una coperta morbida.
- Identificare, suddividere e contare tutte le parti con etichetta.
- Trovare la posizione adatta per il montaggio in base al disegno e montare lo scaffale seguendo correttamente i vari passaggi.



ALTRO

- Per il montaggio sono necessarie 1-2 persone
- Tempo stimato di montaggio 3-5 minuti

⚠ ATTENZIONE

- Prestare molta attenzione quando si utilizza un trapano elettrico o un cacciavite elettrico.
- Rallentare con accortezza e fermarsi quando una vite è già sufficientemente serrata.
- Non utilizzare prodotti chimici aggressivi o detergenti abrasivi su questo articolo.
- Spingere, tirare o trascinare questo articolo con cautela.

NÜTZLICHE HINWEISE

⚠ BEVOR SIE BEGINNEN

- Überprüfen Sie die Produktverpackung auf Schäden.
- Lesen Sie sich die Montageanleitung sorgfältig durch und befolgen Sie sie Schritt für Schritt.
- Um etwaiges Zerkratzen zu vermeiden, wird das Auslegen einer weichen Decke auf dem Boden empfohlen.
- Identifizieren, sortieren und zählen Sie alle Teile mit Tags nach.
- Identifizieren Sie die Montageposition gemäß der Zeichnung und bauen Sie das Regal den richtigen Schritten entsprechend auf.



SONSTIGES

- Se requieren 1-2 personas para el montaje.
- Tiempo estimado de montaje 3-5 minutos

⚠ VORSICHT

- Seien Sie bei der Verwendung einer Bohrmaschine oder eines Akkuschraubers vorsichtig.
- Bitte vergessen Sie nicht darauf, langsamer zu werden und zu stoppen, sobald die Schraube fast festgezogen ist.
- Verwenden Sie keinerlei aggressive Chemikalien oder scheuernden Reinigungsmittel für dieses Produkt.
- Schieben oder ziehen Sie dieses Produkt vorsichtig.

温馨提示

⚠ 安装前注意事项

- 检查产品包装，确保外观良好。
- 仔细阅读安装说明，按步骤操作。
- 为了避免刮伤，建议在地板上放一条柔软的毯子。
- 标识、分类和清点所有部件。
- 根据图形找到安装孔位，按正确步骤安装。



其他：

- 组装所需人员1-2人。
- 预计组装时间3-5分钟。

⚠ 注意：

- 小心使用电钻或电动螺丝刀。
- 当螺丝快要拧紧时，请注意减速
- 不要使用任何刺激性化学物质或清洗剂。
- 当推、拉或拖动产品时，注意小心谨慎，防止损坏。

役に立つヒント

⚠ 組立の場所を確保し、順番通りに組み立てる

- 組立場所（充分広くて平たい場 所）を確保してください。
- 床や壁、商品を傷つけないように、商品の下に厚めの布や段ボールなどを敷いてください。
- 組立の順番を守らないと、組立できなくなったり、商品を傷つけたりします。



その他

- 組み立てには1~2人が必要です
- 組み立て時間の目安は3~5分です

⚠ 部品を確認する

- ネジ類などの部品番号、形状を説明書の部品一覧で確認してください。
- 部品をなくさないように纏めて置いてください。
- 部品を取り出すときに使う分だけ取り出してください。

DETAILS

DETAILS
DÉTAILS/POINTS DE MONTAGE
NOTE PARTICOLARI

DETALLES
組み立てのポイント
詳細情報

UNIT:INCH/CM/厘米

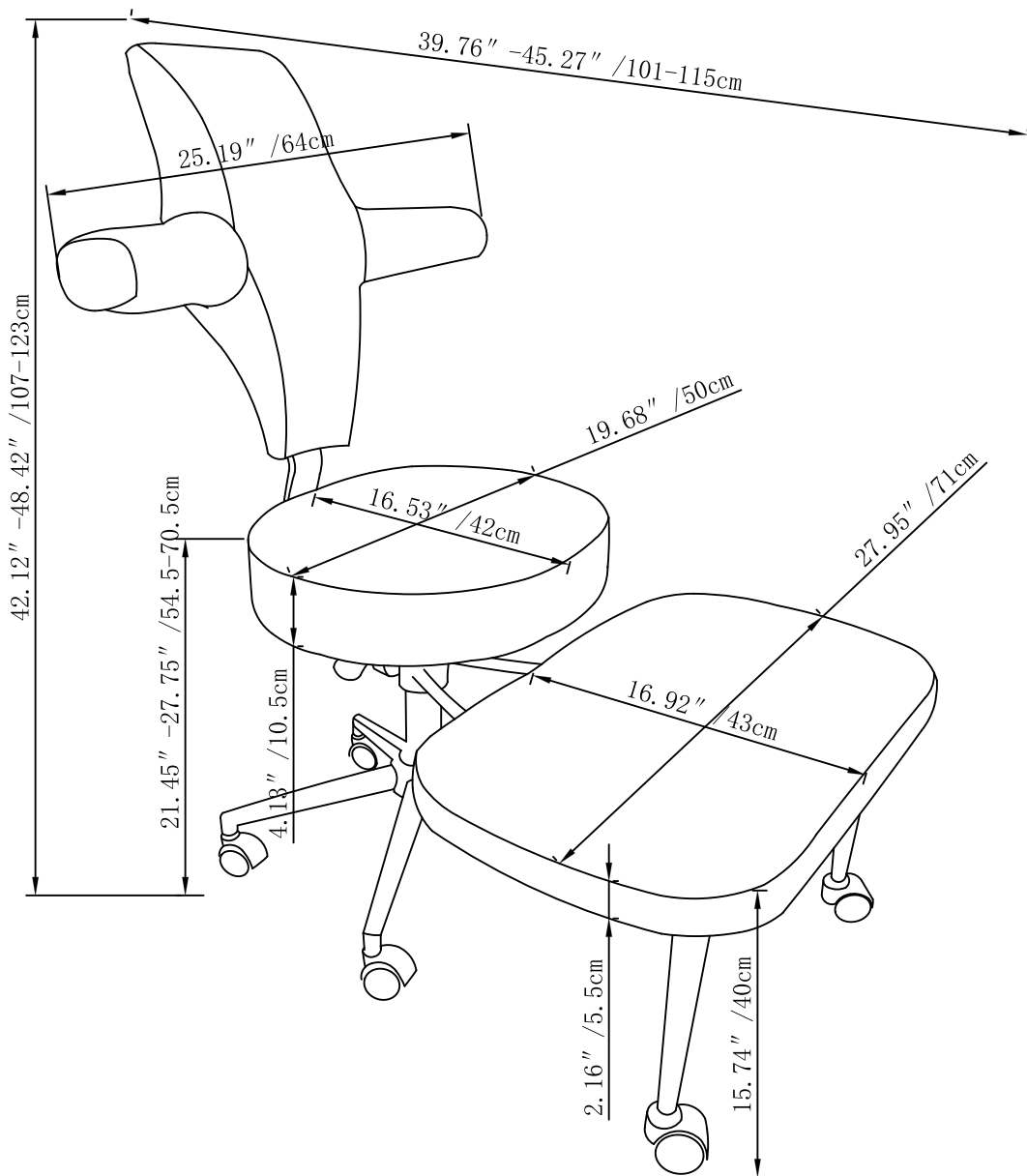

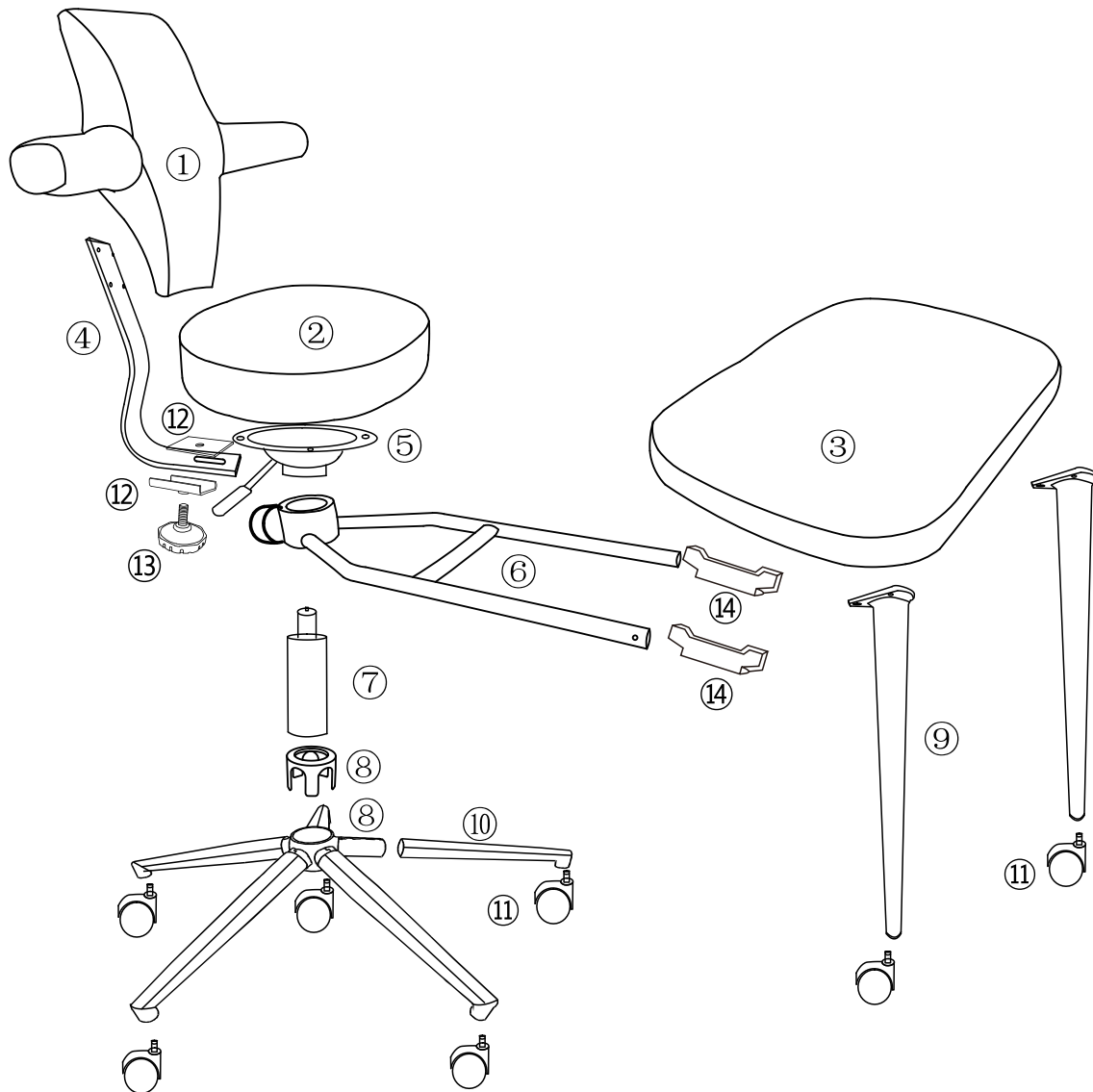





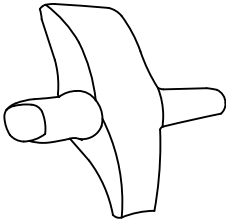
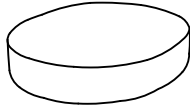
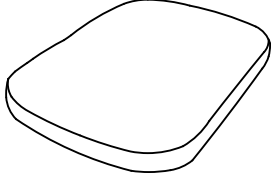

PART LIST

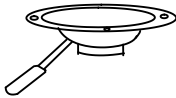
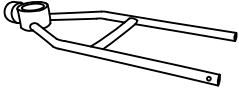
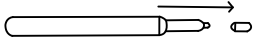
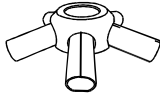
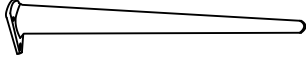
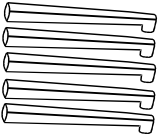
STÜCKLISTE
LISTE DES PIÈCES
ELENCO DEI PEZZI

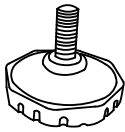
LISTA DE PIEZAS
部品の確認
部件清单

<p>①</p>  <p>X1</p>	<p>②</p>  <p>X1</p>	<p>③</p>  <p>X1</p>
<p>④</p>  <p>X1</p>	<p>⑤</p>  <p>X1</p>	<p>⑥</p>  <p>X1</p>
<p>⑦</p>  <p>PLEASE REMOVE</p> <p>X1</p>	<p>⑧</p>  <p>X1</p>	<p>⑨</p>  <p>X2</p>
<p>⑩</p>  <p>X1</p>	<p>⑪</p>  <p>X7</p>	<p>⑫</p>  <p>X1</p>
<p>⑬</p>  <p>X1</p>	<p>⑭</p>  <p>X2</p>	

ACCESSORY LIST			ZUBEHÖRLISTE LISTE DES ACCESSOIRES ELENCO DEGLI ACCESSORI	LISTA DE ACCESORIOS 付属品部品の確認 配件清單
A	M6*14mm	10+1		
B	M6*18mm	6+1		
C	M5*8mm	2+1		
D	M6*25mm	4+1		
E	M6*20mm	8+1		
F	M6*45mm	4+1		
G	M6	1		

Using the wrong screw size may cause the chair to be damaged or not properly secured.

1

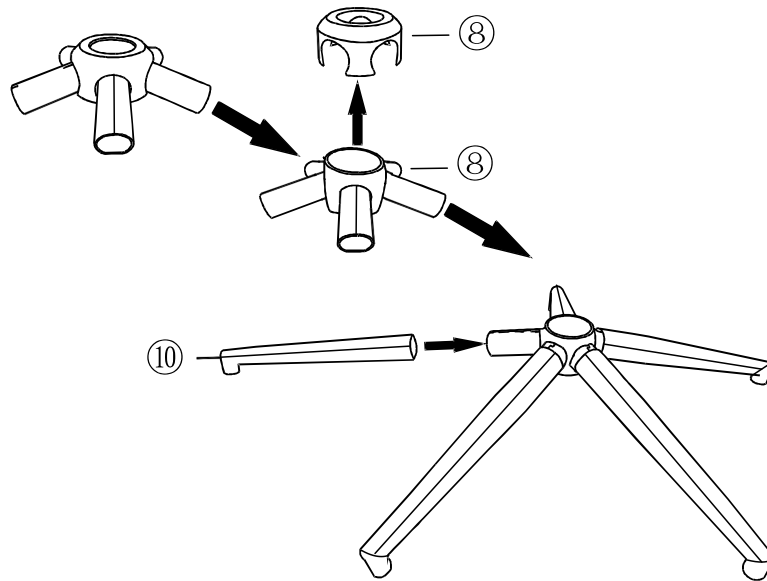

2

- ※Fully tighten all screws.
- ※Serrez complètement toutes les vis.
- ※Ziehen Sie alle Schrauben vollständig an.
- ※Serrare completamente tutte le viti.
- ※Apriete a tope los tornillos.
- ※すべてのネジをしっかり締める。
- ※锁紧全部螺丝

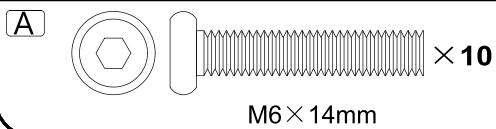
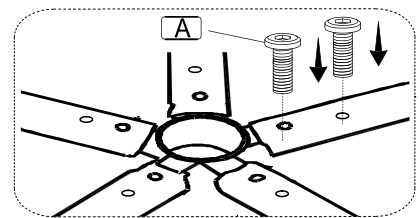
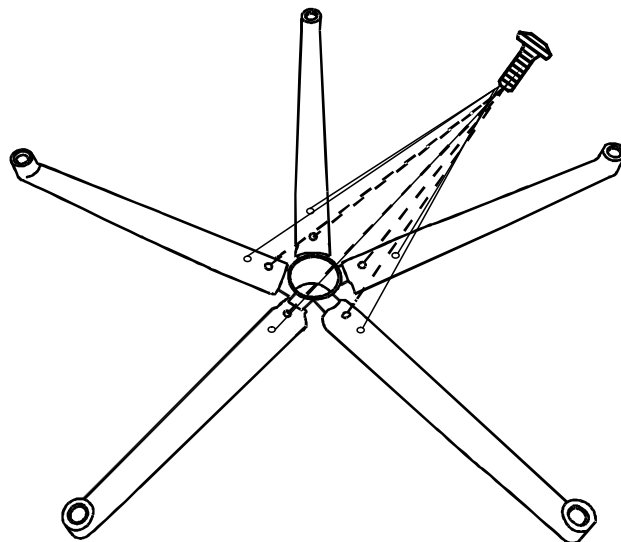

3

As shown in the picture: The air rod can be used normally only after the air rod cap is removed.

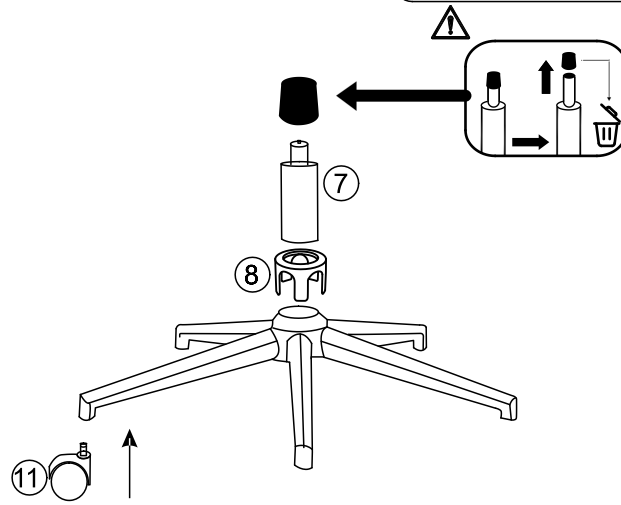

4

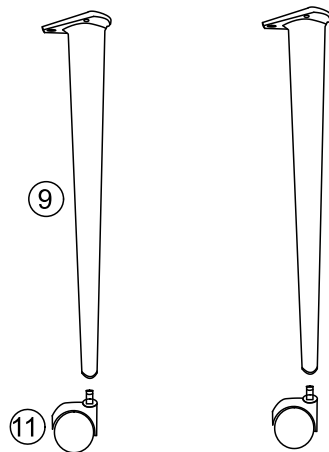

5

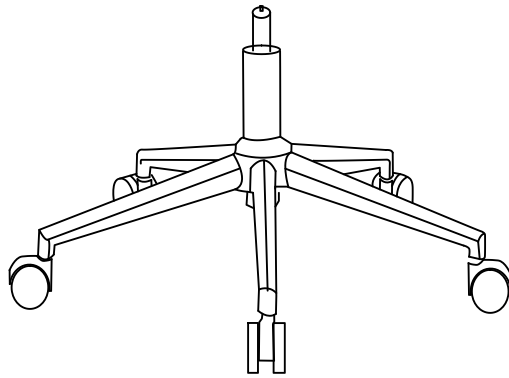

6

※Fully tighten all screws.
 ※Serrez complètement toutes les vis.
 ※Ziehen Sie alle Schrauben vollständig an.
 ※Serrare completamente tutte le viti.
 ※Apriete a tope los tornillos.
 ※すべてのネジをしっかり締める。
 ※锁紧全部螺丝

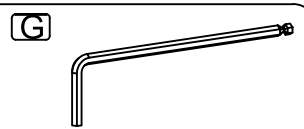
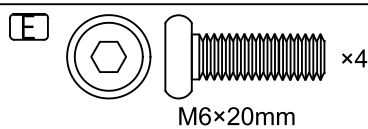
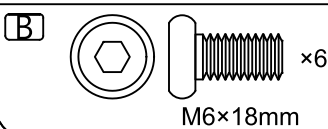
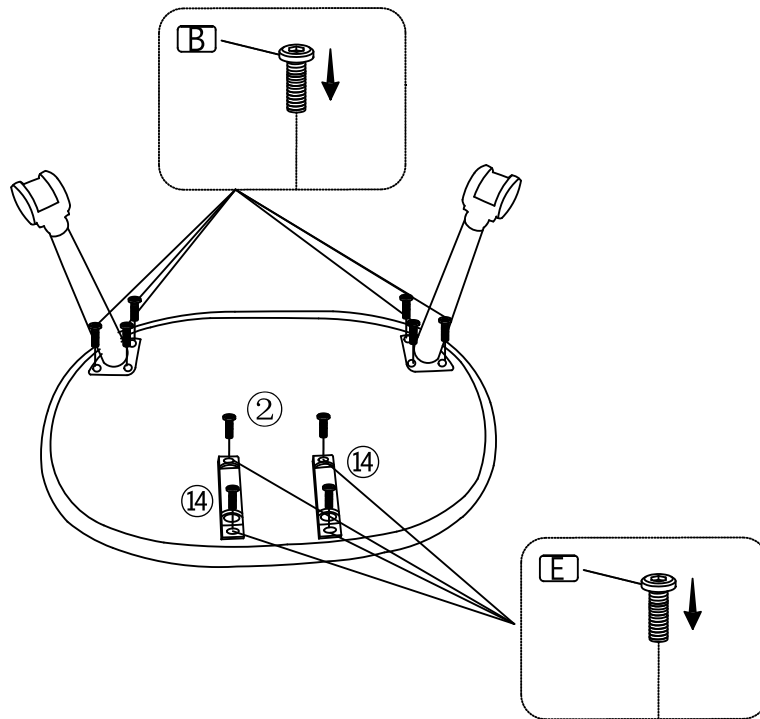

5

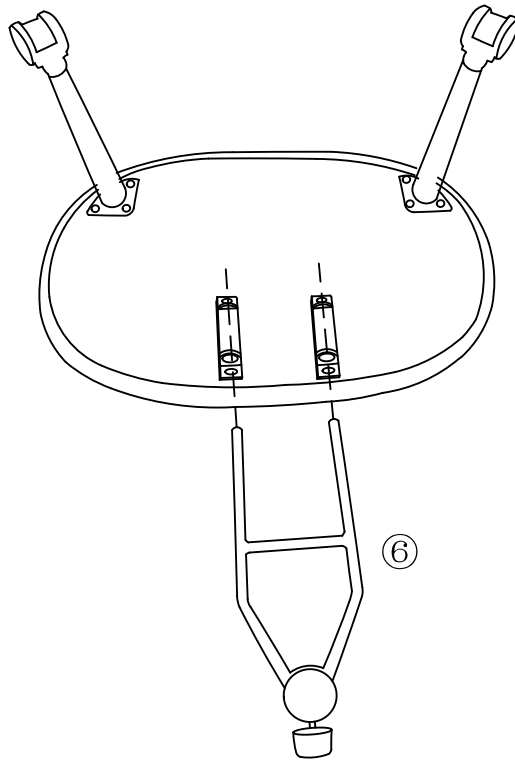

6

- ※Fully tighten all screws.
- ※Serrez complètement toutes les vis.
- ※Ziehen Sie alle Schrauben vollständig an.
- ※Serrare completamente tutte le viti.
- ※Apriete a tope los tornillos.
- ※すべてのネジをしっかり締める。
- ※锁紧全部螺丝

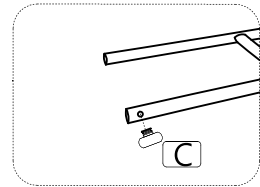
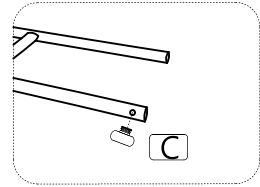
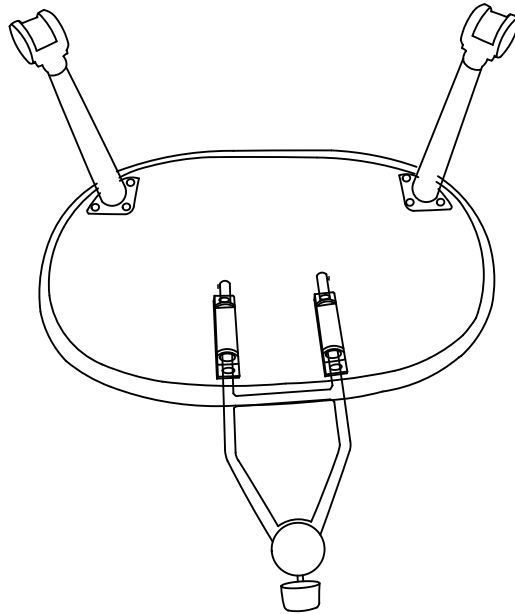

C

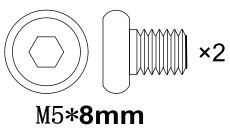

G

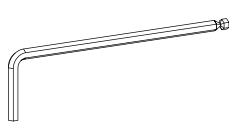

L502085M

7

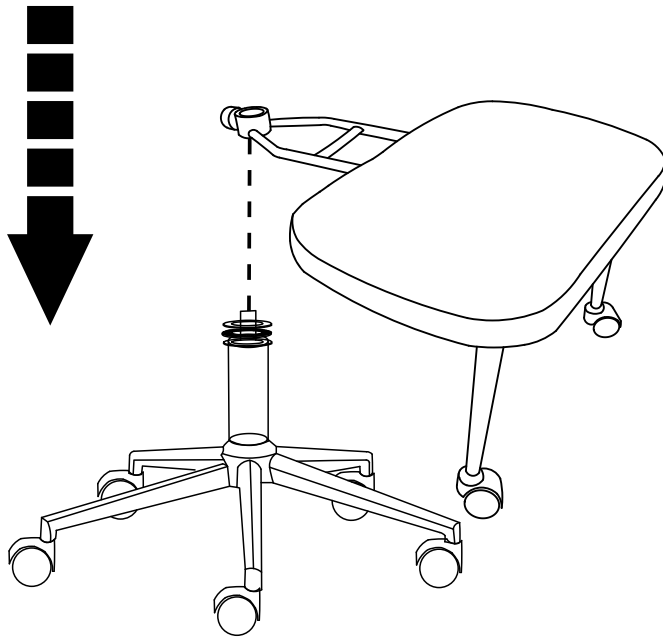

8

- ※Fully tighten all screws
- ※Serrez complètement toutes les vis
- ※Ziehen Sie alle Schrauben vollständig an
- ※Serrare completamente tutte le viti
- ※Apriete a tope los tornillos
- ※すべてのネジをしっかり締める。
- ※锁紧全部螺丝

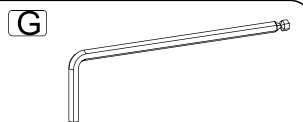
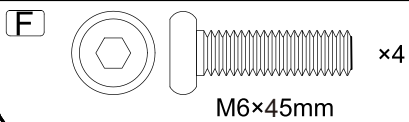
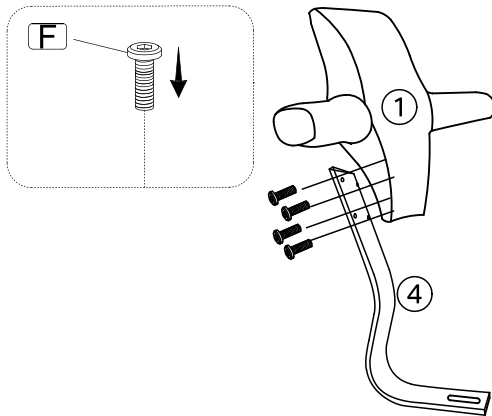

9

80% tighten
 80 % serré
 80% festziehen
 Serraggio al 80%
 80 % reforzado
 80%締め付け
 80%锁紧

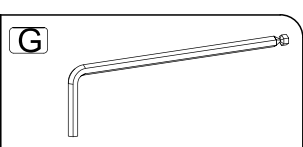
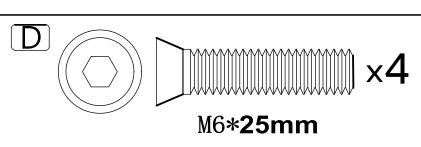
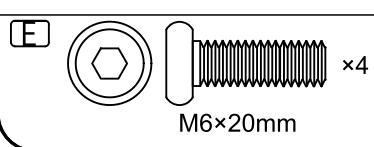
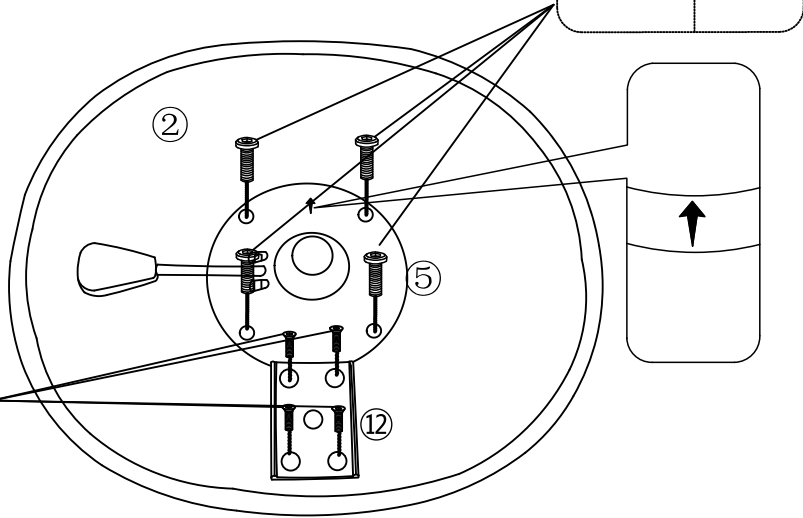

10

※Fully tighten all screws
 ※Serrez complètement toutes les vis
 ※Ziehen Sie alle Schrauben vollständig an
 ※Serrare completamente tutte le viti
 ※Apriete a tope los tornillos
 ※すべてのネジをしっかり締める。
 ※锁紧全部螺丝

✗ **Incorrect installation sequence:**
 Install the back connecting iron first and then the tray,
 resulting in the failure to install the tray.

✓ **Correct installation sequence:**
 Install the tray first and then the back connecting iron.

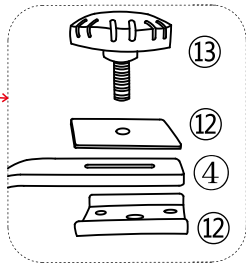
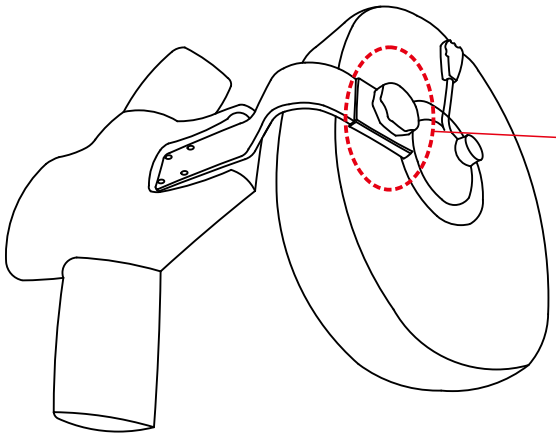

11

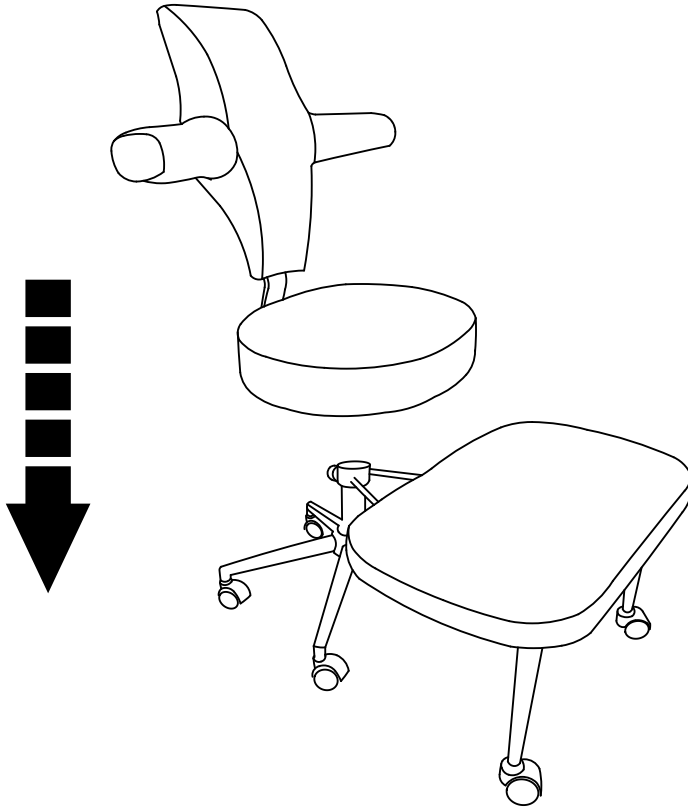

12



No one is allowed to sit in the front third of the footrest



Love coming home.

Comfort Zone Co., Limited

RM1903 19F BeiYou technology Building, Yuehai Street,
No.42 Gaoxin South Ring Road, Nanshan, Shenzhen

CUSTOMER SUPPORT	
North American	Global
888-666-1086	Service.US@pinmoco.com
Service.US@pinmoco.com	