

Assembly | Asambla | Assemblage

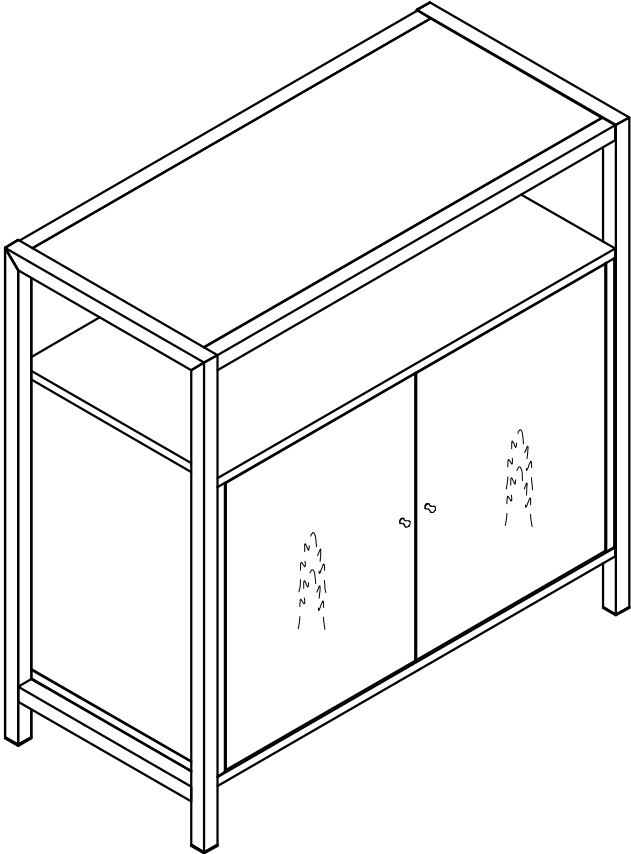

Assembly | Asambla | Assemblage

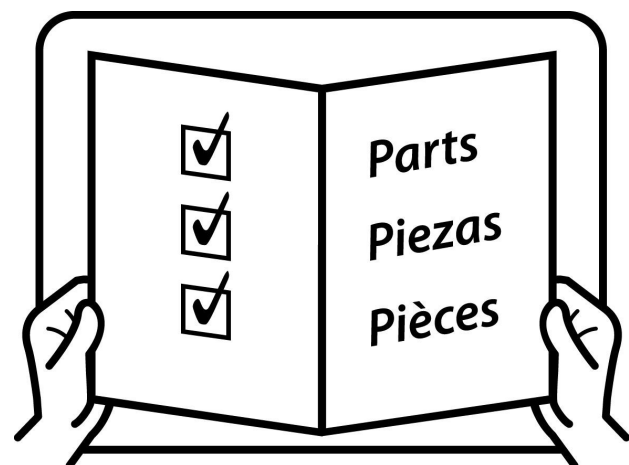
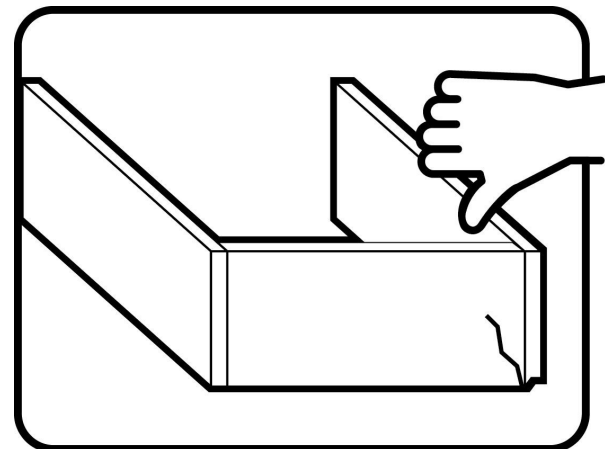
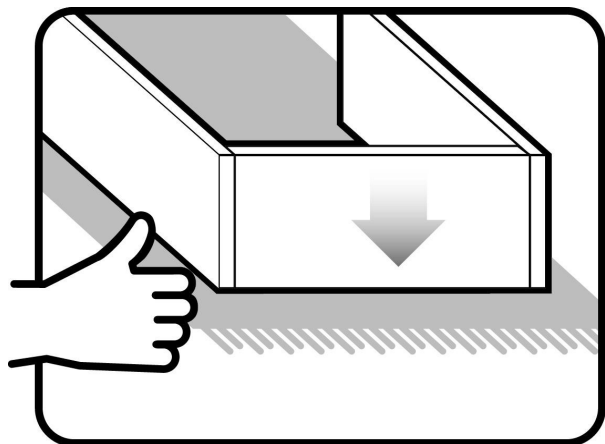
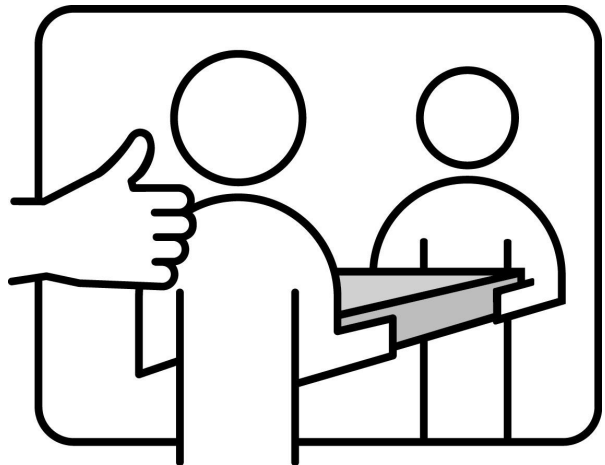
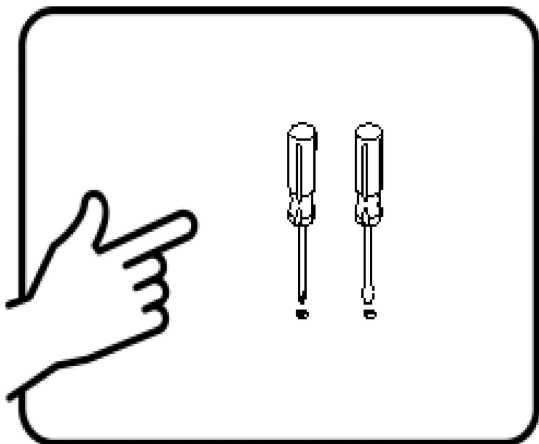

Assembly | Asamlea | Assemblage

Techniques | Técnicas | Techniques

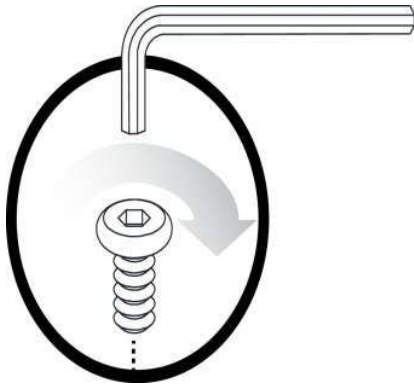

Care | Cuidado | Entretien



Safety | Seguridad | Sécurité









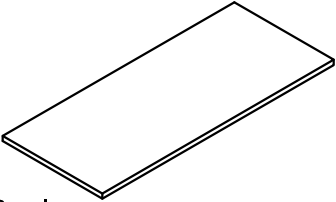
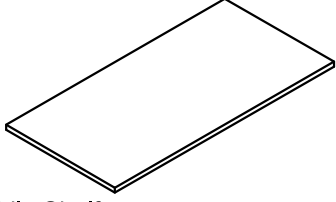
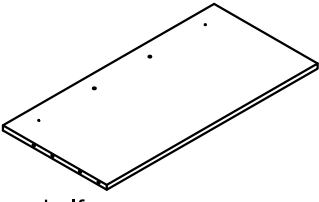
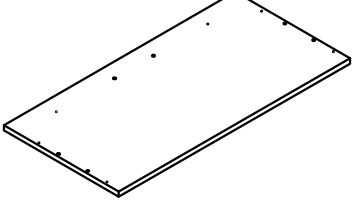
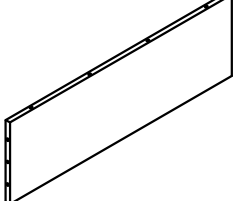
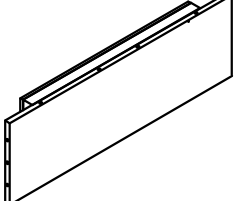
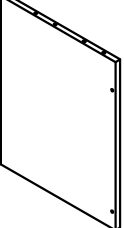
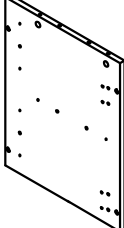
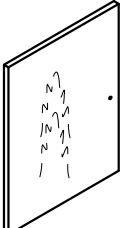
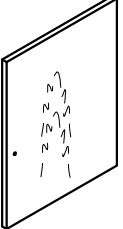
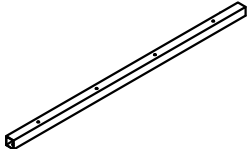
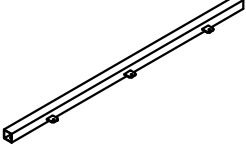
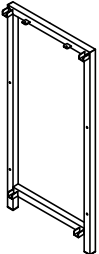
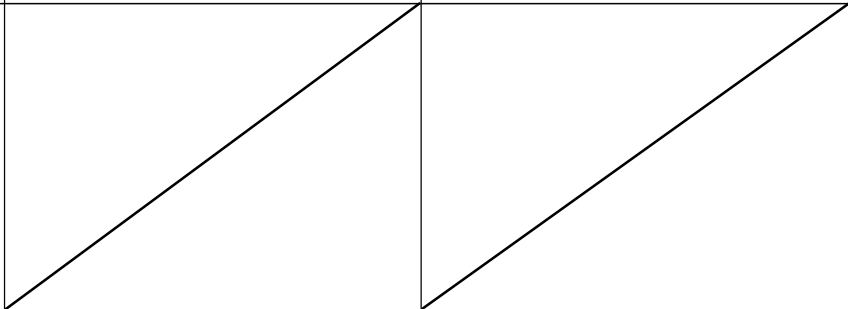



Note! | ¡Nota! | Remarque!

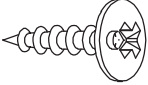
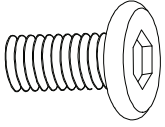

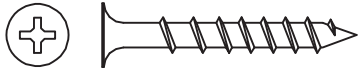
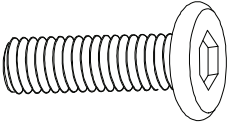
Assembly | Asambla | Assemblage

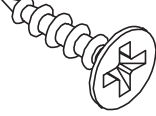
<p>A x1</p>  <p>Top Panel Panel superior Panneau supérieur</p>	<p>B x1</p>  <p>Middle Shelf Estante central Étagère centrale</p>	<p>C x1</p>  <p>Interior shelf Estante interior Étagère intérieure</p>
<p>D x1</p>  <p>Bottom Panel Panel inferior Panneau inférieur</p>	<p>E x1</p>  <p>Upper Back Panel Panel trasero superior Panneau dorsal supérieur</p>	<p>F x1</p>  <p>Bottom Back Panel Panel trasero inferior Panneau arrière inférieur</p>
<p>G x1</p>  <p>Left Side Panel Panel lateral izquierdo Panneau latéral gauche</p>	<p>H x1</p>  <p>Right Side Panel Panel lateral derecho Panneau latéral droit</p>	<p>I x1</p>  <p>Left Door Puerta izquierda Porte gauche</p>
<p>J x1</p>  <p>Right Door Puerta derecha Porte droite</p>	<p>K x2</p>  <p>Bottom Support Rail Riel de soporte inferior Rail de support inférieur</p>	<p>L x2</p>  <p>Top Support Rail Carril de soporte superior Rail de support supérieur</p>
<p>M x2</p>  <p>Side Frame Bastidor lateral Cadre latéral</p>		

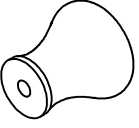
Assembly | Asamblea | Assemblage

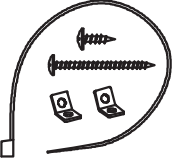
<p>1 x22</p>  <p>Cam Bolt Perno de leva Boulon à came</p>	<p>2 x22</p>  <p>Cam Lock Bloqueo de leva Serrure à came</p>	<p>3 x10</p>  <p>Pan Head Screw Tornillo de cabeza plana Vis à tête cylindrique M3.5 x 12mm</p>
<p>4 x8</p>  <p>Bolt Cerrojo Boulon Ø1/4" x 1/2"L</p>	<p>5 x24</p>  <p>Wood Dowel Clavija de madera Cheville en bois</p>	<p>6 x14</p>  <p>Screw Tornillo Vis M4 x 35mm</p>
<p>7 x8</p>  <p>Bolt Cerrojo Boulon Ø1/4" x 1"L</p>	<p>8 x4</p>  <p>Hinge Bisagra Gond</p>	<p>9 x24</p>  <p>Screw Tornillo Vis M4 x 15mm</p>
<p>10 x2</p>  <p>Pan Head Bolt Perno de cabeza plana Boulon à tête cylindrique Ø5/32" x 19mm</p>	<p>11 x2</p>  <p>Knob Perilla Pommeau</p>	<p>12 x1</p>  <p>Allen Wrench Llave Allen Clef Allen</p>
<p>13 x1</p>  <p>Tipping Restraint Hardware Herrajes de sujeción de vuelco Quincaillerie de retenue de basculement</p>		

Assembly | Asambllea | Assemblage

1

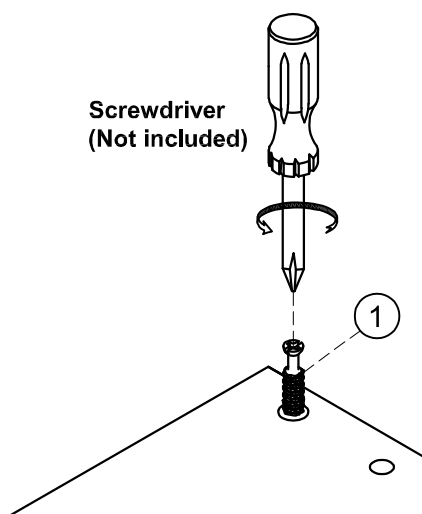
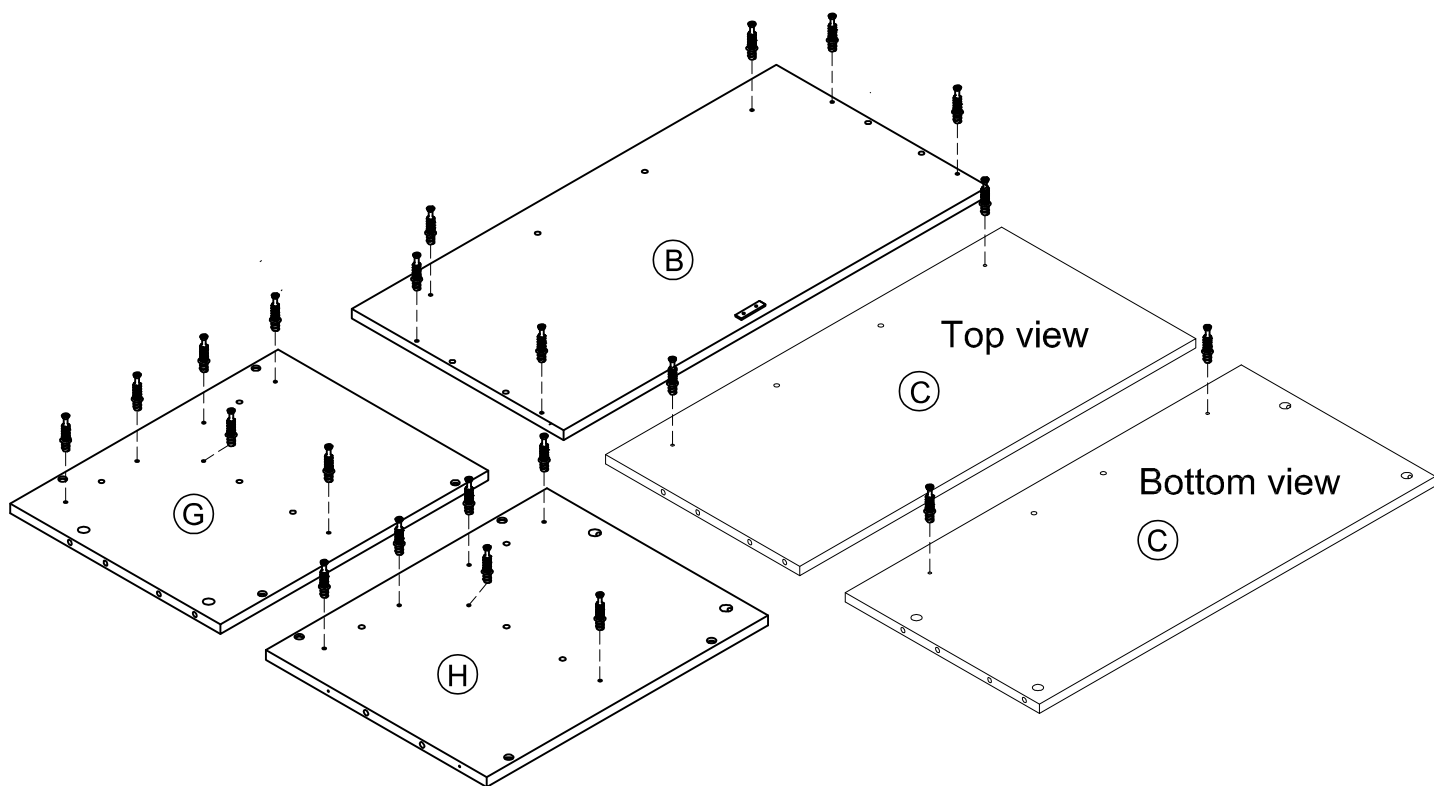
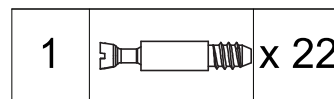

Assembly | Asambla | Assemblage

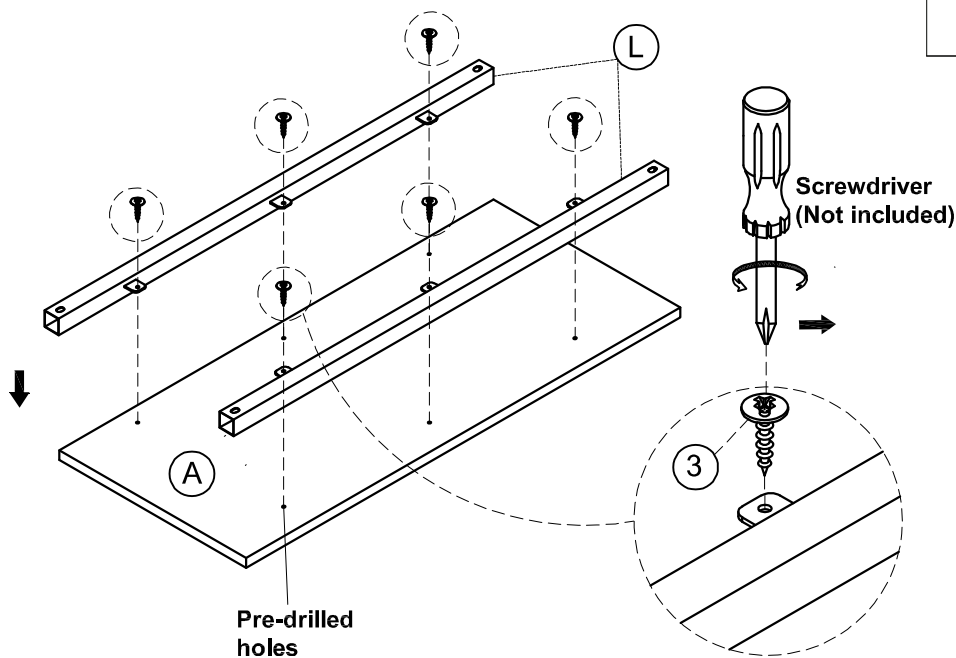

2

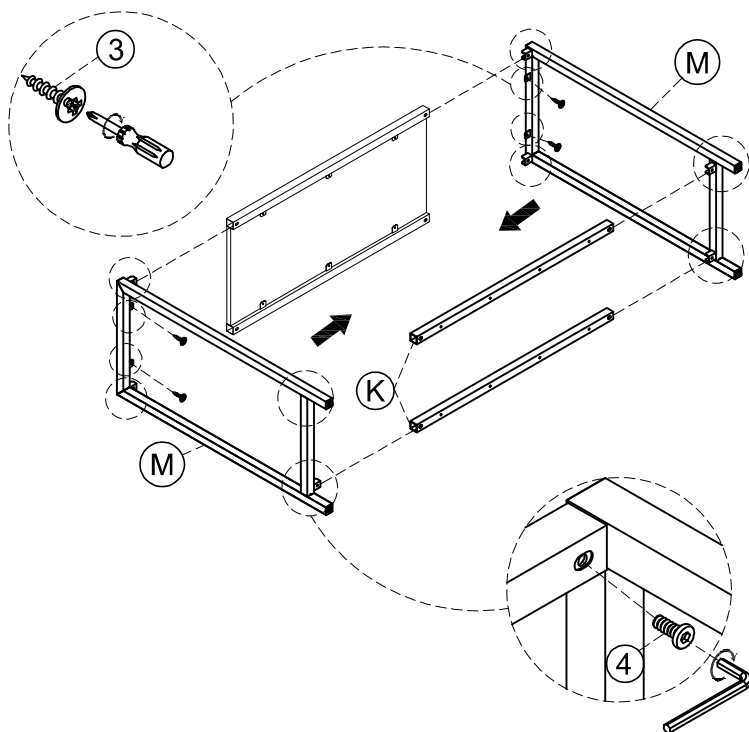

3		x 6
---	---	-----

3



3		x 4
4		x 8

Assembly | Asambla | Assemblage

4

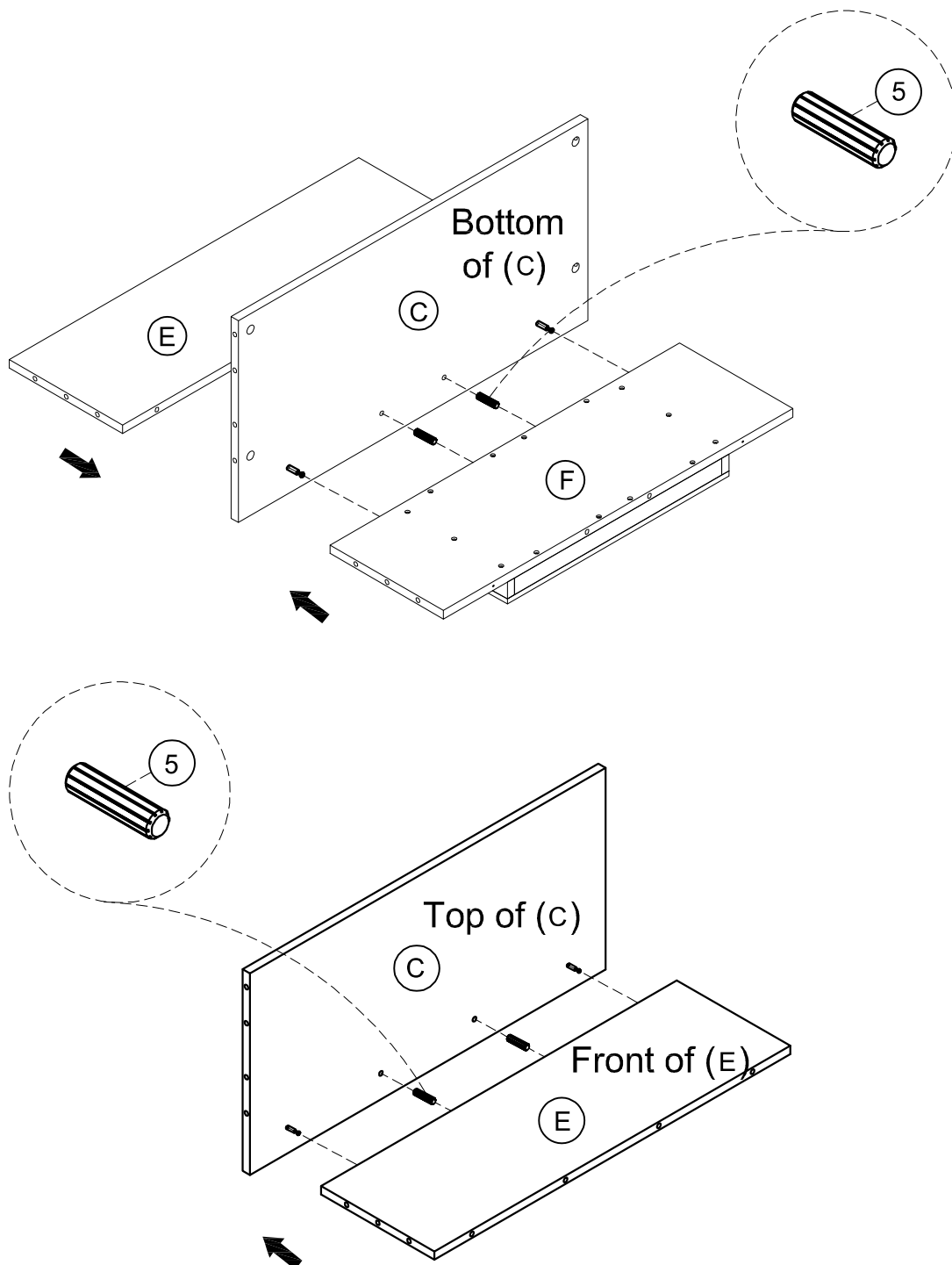

5		x 4
---	---	-----



Assembly | Asambllea | Assemblage

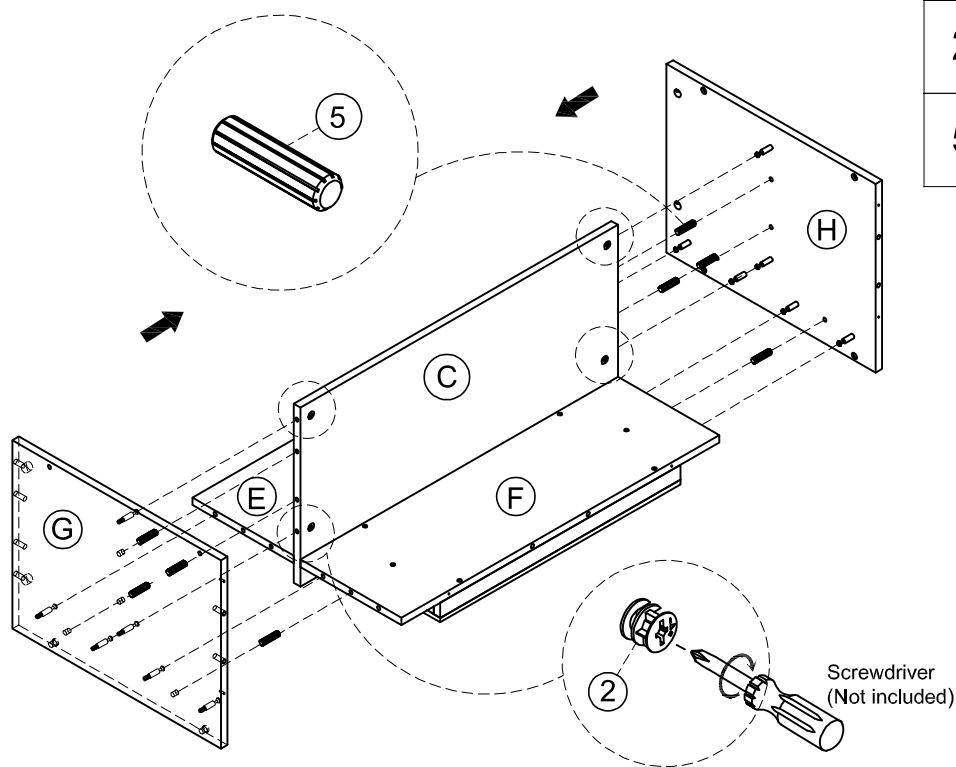

5

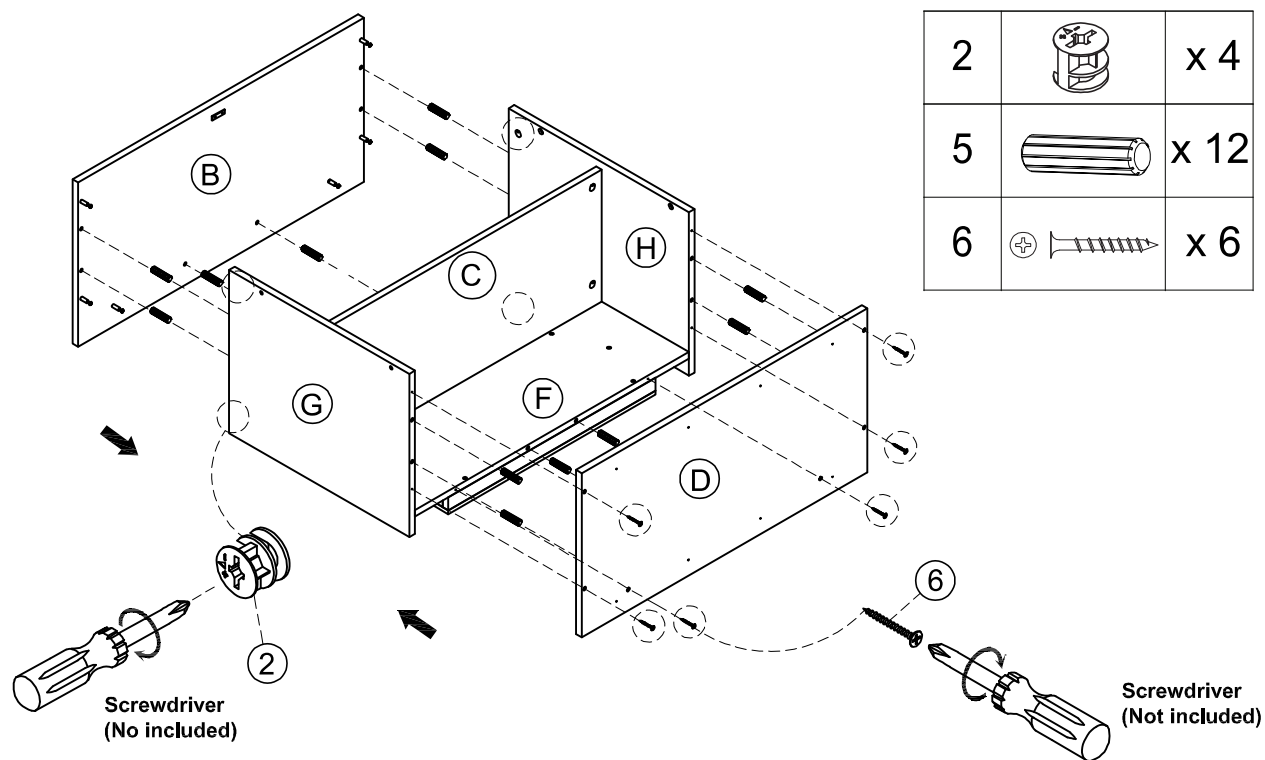

2		x 4
5		x 8

6

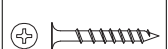

2		x 4
5		x 12
6		x 6

Assembly | Asambllea | Assemblage

7

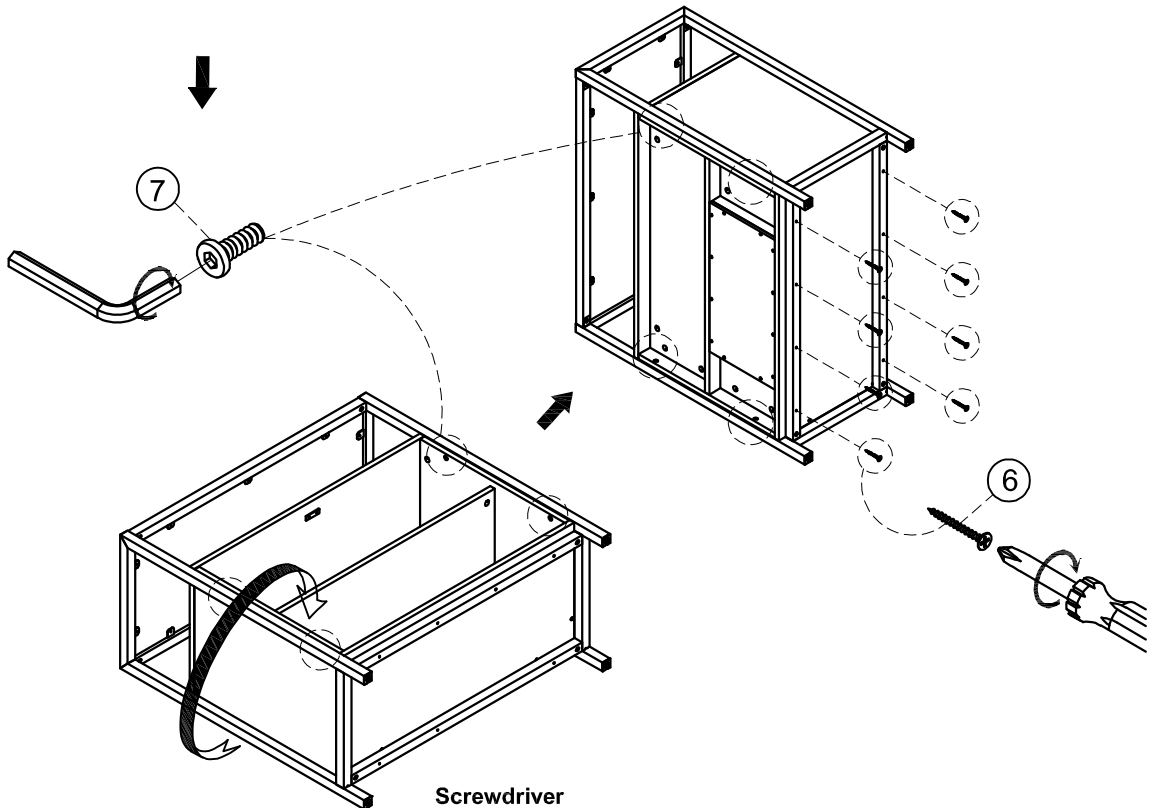
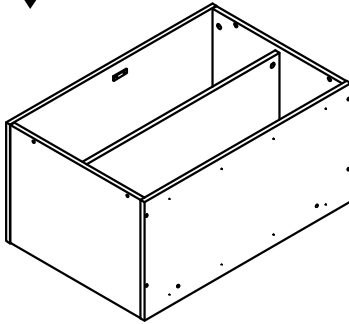
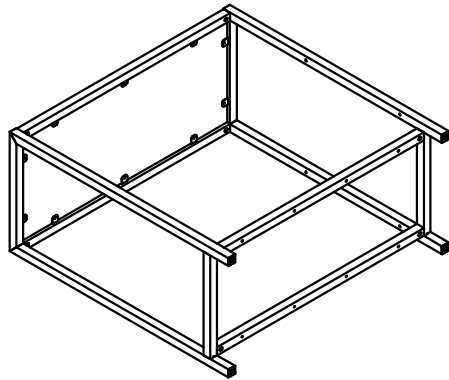

Screwdriver
(Not included)

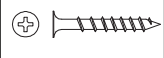
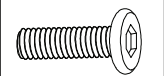
6		x 8
7		x 8



Assembly | Asambla | Assemblage

8

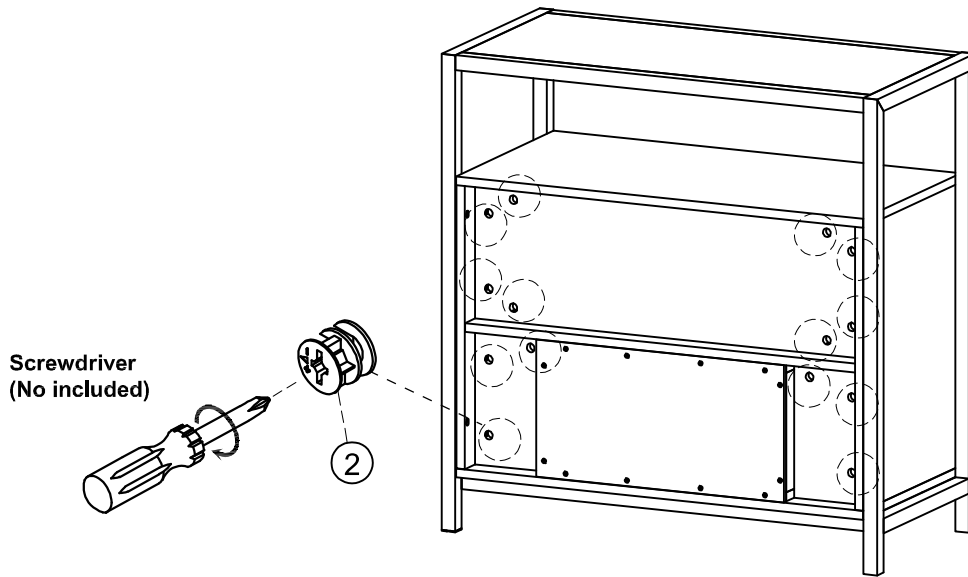
2		x 14
---	---	------



9

8		x 4
9		x 8

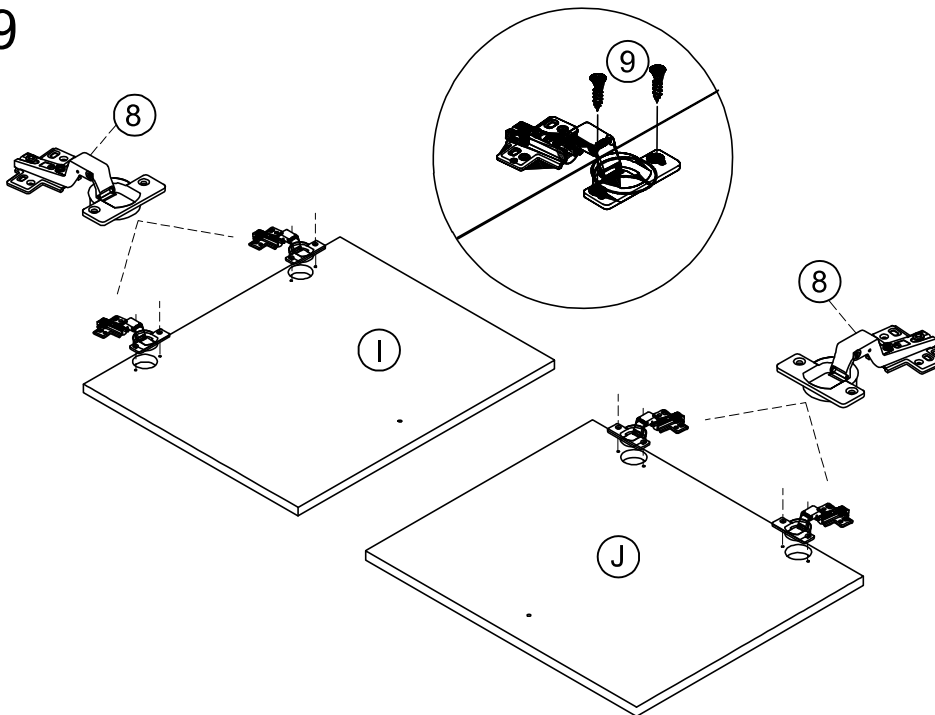

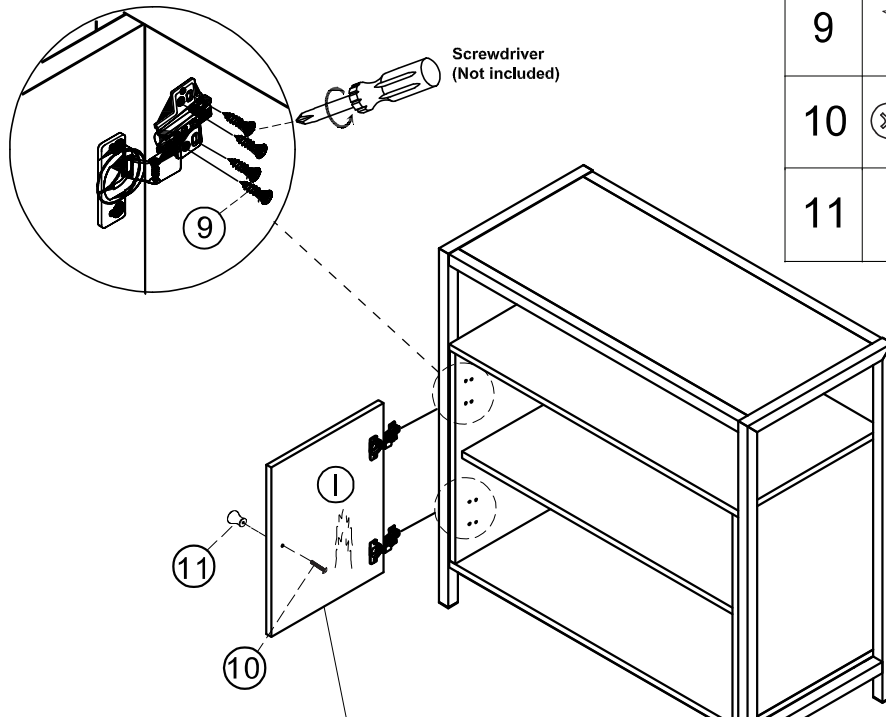

Assembly | Asambla | Assemblage

10



Screwdriver
(Not included)



9		x 8
10		x 1
11		x 1

Make sure that the "V" pattern on door panel should be upside down
Asegúrese de que el patrón de "V" en el panel de la puerta esté al revés
Assurez-vous que le motif en « V » sur le panneau de porte doit être à l'envers

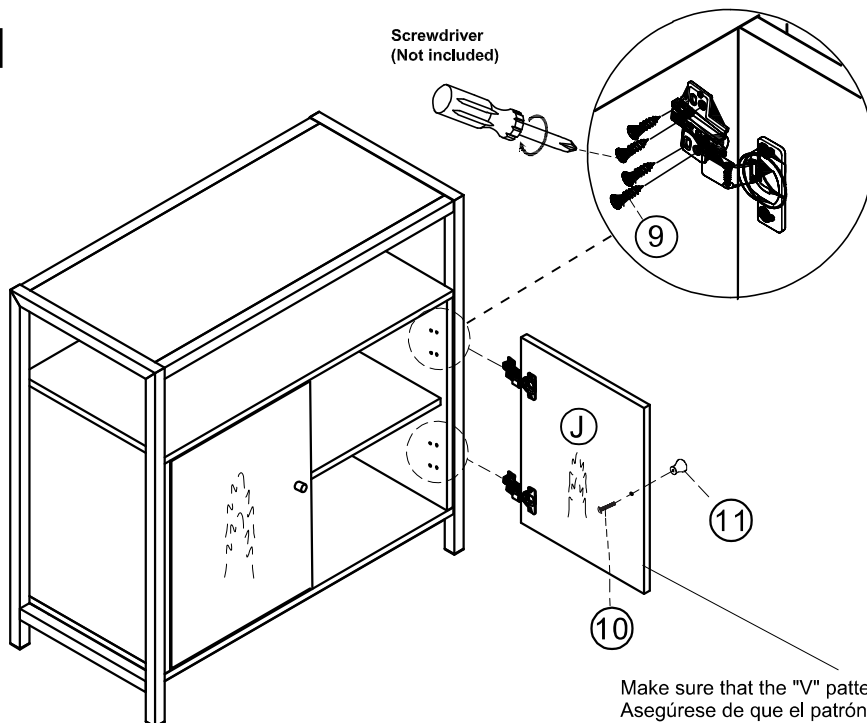
11



Screwdriver
(Not included)

9		x 8
10		x 1
11		x 1

Make sure that the "V" pattern on door panel should be upside down
Asegúrese de que el patrón de "V" en el panel de la puerta esté al revés
Assurez-vous que le motif en « V » sur le panneau de porte doit être à l'envers

Assembly | Asambla | Assemblage

12

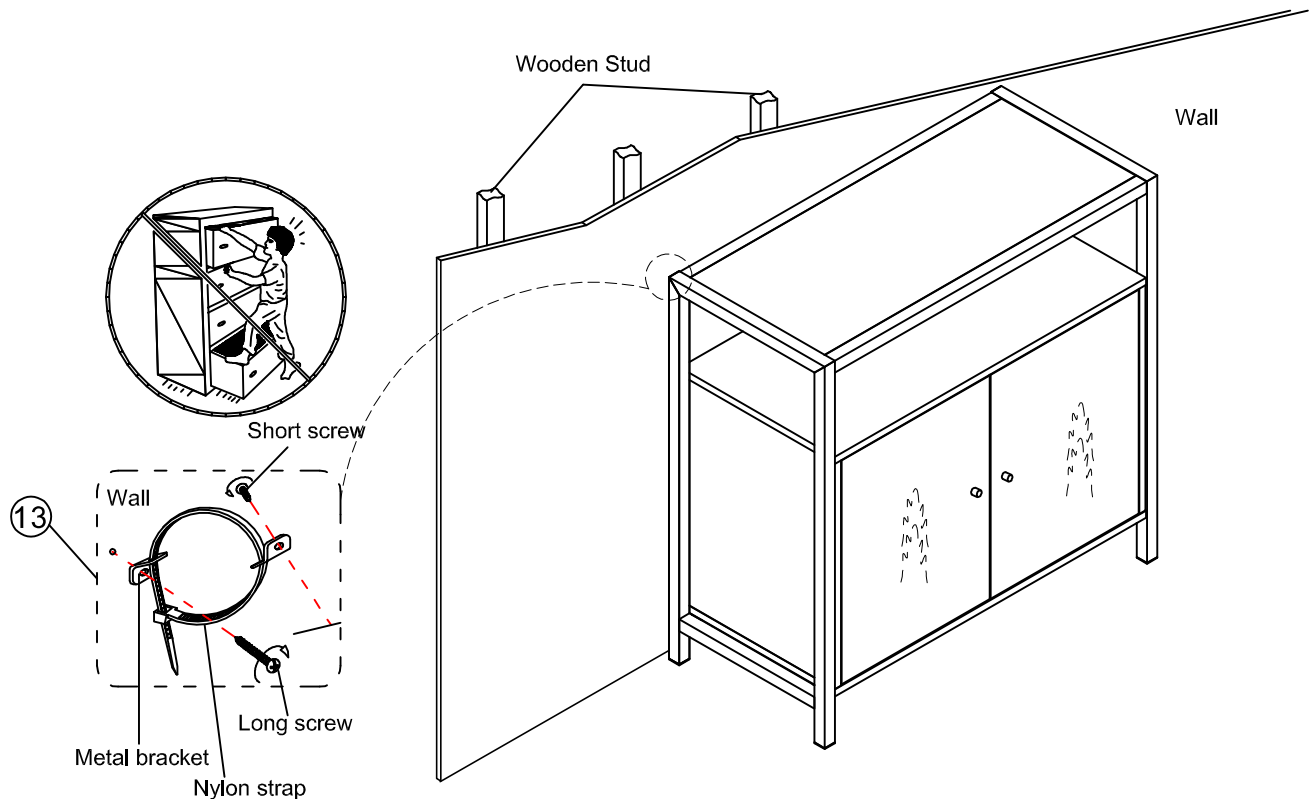
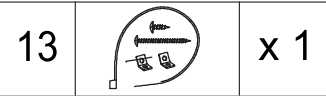

Now, follow the instructions printed on the plastic bag containing the Tipping Restraint Hardware to attach the tip-over restraints to the unit and the wall.

NOTE: The tipping restraint hardware included is for wooden stud wall construction. It must be attached to wall stud. Depending upon your wall construction, different anchor hardware may be required. Please contact your local hardware store for assistance. Young children can be seriously injured by tipping furniture. You must install the tipping restraints hardware with the unit to prevent the unit from tipping, causing any accidents or damage. The tipping restraints are intended only as a deterrent, they are not a substitute for proper adult supervision. The tipping restraints are not earthquake restraints. If you wish to add the extra security of earthquake restraints, they must be purchased and installed separately.

Ahora, siga las instrucciones impresas en la bolsa de plástico que contiene el hardware de restricción de vuelco para colocar las restricciones de vuelco en la unidad y la pared.

Nota: Los herrajes de restricción de vuelco incluidos son para la construcción de paredes de montantes de madera. Debe estar unido a un montante de pared. Dependiendo de la construcción de su pared, es posible que se requieran diferentes herrajes de anclaje. Póngase en contacto con la ferretería local para obtener ayuda. Los niños pequeños pueden sufrir lesiones graves al volcar los muebles. Debe instalar el hardware de restricción de vuelco con la unidad para evitar que la unidad se vuelque y cause accidentes o daños. Las restricciones de vuelco están destinadas solo como un elemento disuasorio, no son un sustituto de la supervisión adecuada de un adulto. Las restricciones de vuelco no son restricciones antisísmicas. Si desea agregar la seguridad adicional de las restricciones antisísmicas, deben comprarse e instalarse por separado.

Maintenant, suivez les instructions imprimées sur le sac en plastique contenant le matériel de retenue de basculement pour fixer les dispositifs de retenue de basculement à l'unité et au mur.

Remarque: Le matériel de retenue de basculement inclus est pour la construction de murs à colombages en bois. Il doit être fixé à un

montant mural. En fonction de la construction de votre mur, différents matériels d'ancrage peuvent être nécessaires. Veuillez contacter la quincaillerie locale pour obtenir de l'aide. Les jeunes enfants peuvent être gravement blessés en renversant des meubles. Vous devez installer le matériel de retenue de basculement avec l'unité pour éviter que l'unité ne bascule et ne provoque des accidents ou des dommages. Les dispositifs de retenue contre le basculement ne sont destinés qu'à avoir un effet dissuasif, ils ne sont pas un substitut à la surveillance appropriée d'un adulte. Les dispositifs de retenue antisismique ne sont pas des dispositifs de retenue antisismique. Si vous souhaitez ajouter la sécurité supplémentaire des dispositifs antisismiques, ils doivent être achetés et installés séparément.

Assembly | Asamblea | Assemblage

Please immediately examine this product carefully. Any request for missing or damaged parts replacement must be received 90 days following the date you received the product. Requests for replacement parts, if available, will be honored within this time frame. Parts will not be available for items that were received fully assembled. We do not recommend modifying products and we are not responsible for any damages due to product modifications. If damages or missing parts are not reported within 90 days of the date you received the product, we are under no obligation to provide parts or replacement merchandise. For assembly issues, please contact customer service and ask for technical assistance. Regarding product returns, please contact the retailer from whom you purchased the product.

Please note, for items purchased in a retail store, you will need to contact the retailer for all part needs.

Product purchased at garage sales or discount stores is sold as-is and is not covered by the above policy.

Por favor, examine ester producto detenidamente. Cualquier solicitud de reemplazo de piezas faltantes on dañadas debe recibirse 90 días después de la fecha en que recibió el producto. Las solicitudes de piezas de repuesto, si están disponibles, se cumplirán dentro de este marco de tiempo. Las piezas no estarán disponibles para los artículos que se recibieron completamente ensamblados. No recomendamos modificar los productos y no nos hacemos responsables de los daños debtos a modificaciones del producto, Si los daños o las piezas faltantes no se informan dentro de los 90 días a partir de la fecha en que recibió el producto, no estamos obligados a proporcionar piezas o mercancía de reemplazo. Para problemas de montaje, comuníquese con el servicio al cliente y solicite asistencia técnica. En cuanto a devoluciones de productos, póngase en contacto el distribuidor al que le compró el producto

Tenga en cuenta que para los artículos comprados en una tienda minorista, deberá ponerse en contacto con el minorista para todas las necesidades de la pieza.

El producto comprado en las ventas de garageje o tiendas de descuento se vende tal cual y no está cubierto por la política anterior.

S'il vous plaît examiner immédiatement ce produit avec soin. Toute demande de remplacement de pièces manquantes ou endommagées doit être reçue dans les 90 jours suivant la date de réception du produit. Les demands for pièces de change, si elles sont disponibles, seront honorées dans ce délai. Les pièces ne seront pas disponibles pour les articles reçus entièrement assemblés. Nous ne recommandons pas de modifier les produits et nous ne sommes pas responsables des dommages causés par les modifications du produit. Si les dommages ou les pièces manquantes ne sont pas signalés dans les 90 jours suivant la date à laquelle vous avez reçu le produit, nous ne sommes pas tenus de fournir des pièces ou des marchandises de remplacement. Pour les problèmes d'assemblage, veuillez contacter le service clientèle et demander une assistance technique. En ce qui concerne les retours de produits,

veuillez contacter le revendeur auprès

duquel vous avez acheté le produit.

S'il vous plaît noter, pour les articles achetés dans un magasin de détail, vous devrez contacter le détaillant pour tous les besoins en pièces.

Les produits achetés dans les ventes de garage ou dans les magasins discount sont vendus tels quels et ne sont pas couverts par la politique cidessus.