

ASSEMBLY INSTRUCTION

ITEM NO.N715P194626

Dining Table

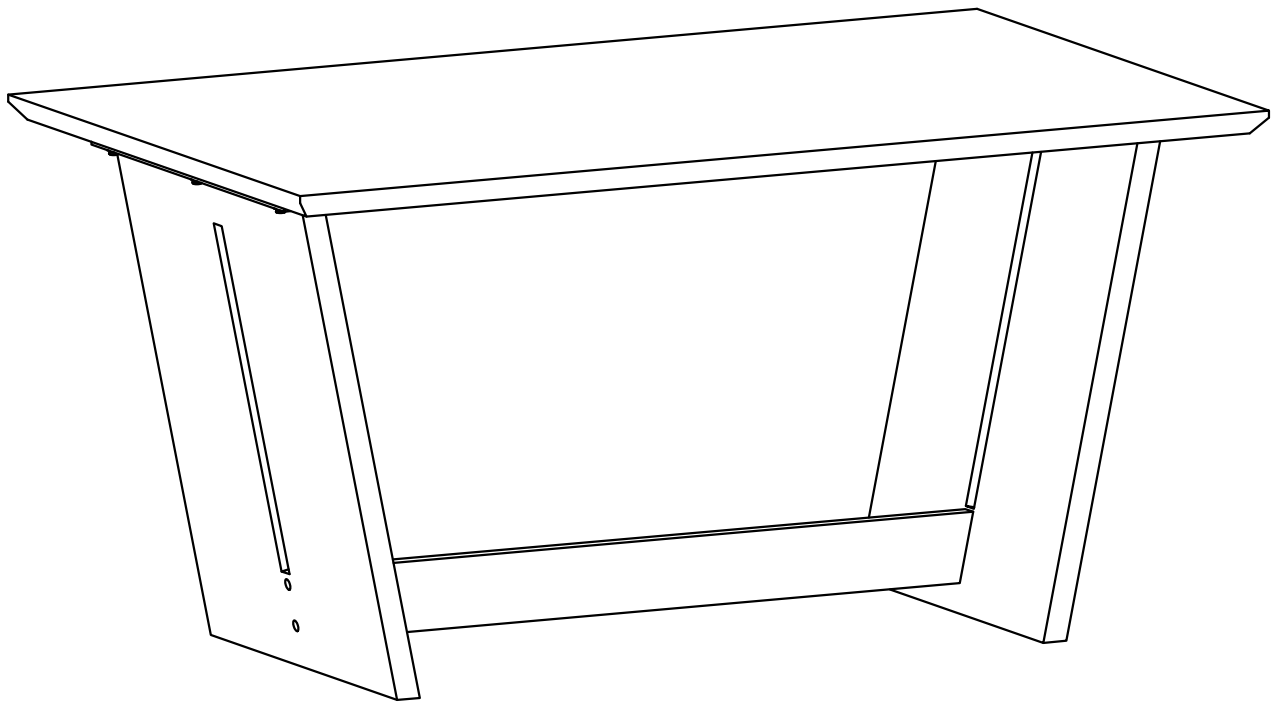

ASSEMBLY INSTRUCTION

ITEM NO.N715P194626

Please read these instructions fully before starting assembly:

1. Place all wooden parts on a clean and smooth surface such as a rug or carpet to avoid scratching the parts.
2. Kindly follow the assembly instructions step by step.
3. Do not tighten all screws and bolts until the stool is fully assembled.
4. Unscrew the protective plastique supports from the metal insert of the table legs before assembly.
5. Parts of the assembly will be easier with 2 people.

Care and maintenance:

Only clean using a damp cloth and mild detergent, do not use bleach or abrasive cleaners.

ASSEMBLY INSTRUCTION

ITEM NO.N715P194626

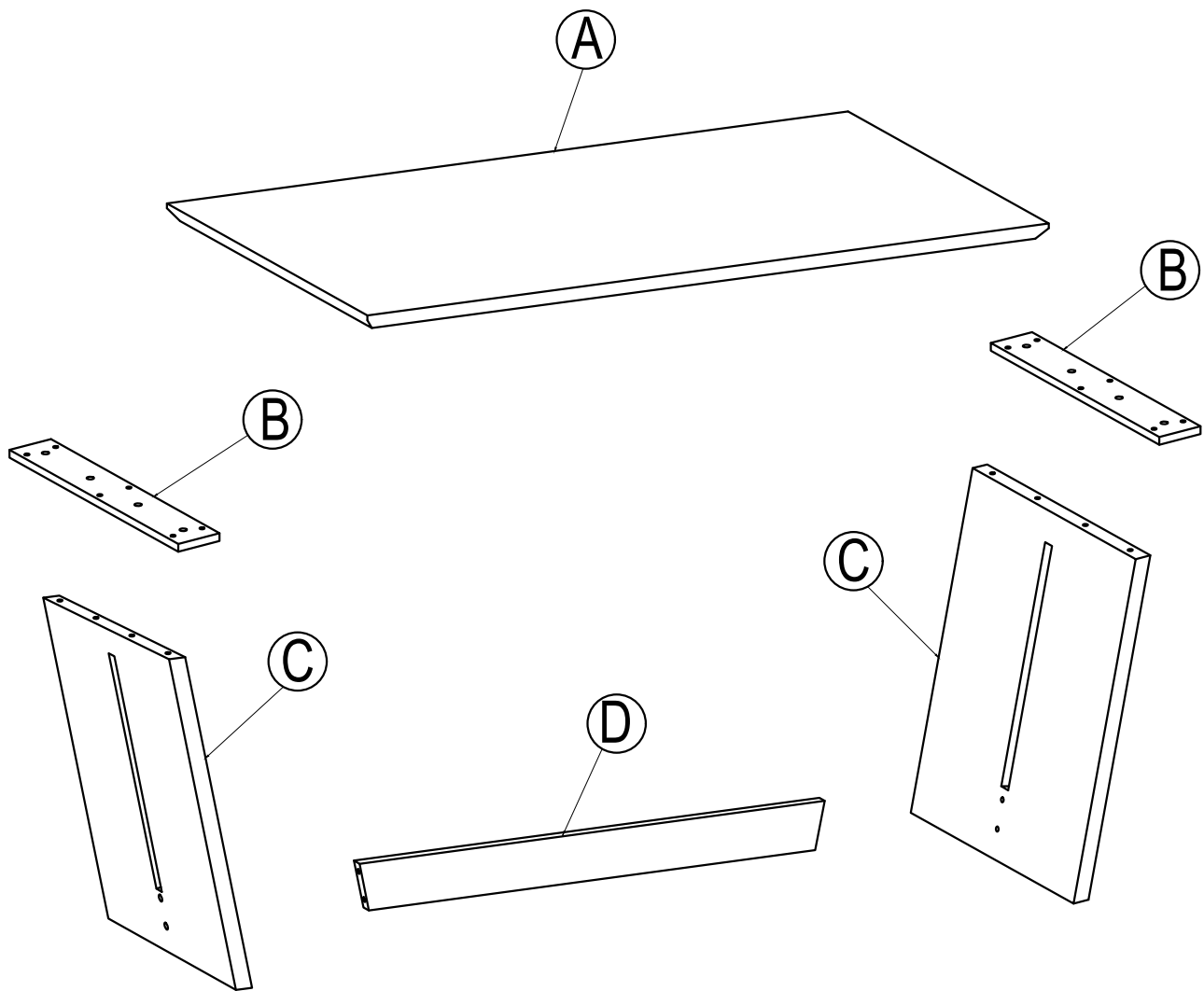

ASSEMBLY INSTRUCTION

ITEM NO.N715P194626

Part List

(A)

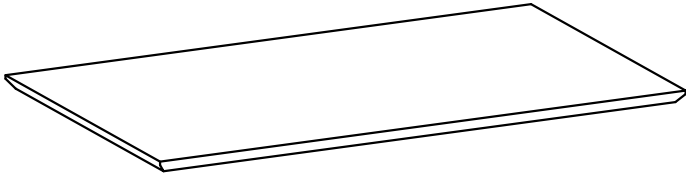
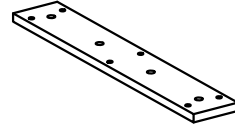

TABLE TOP (1 pc)

(B)



PANEL TOP LEG (2 pcs)

(C)

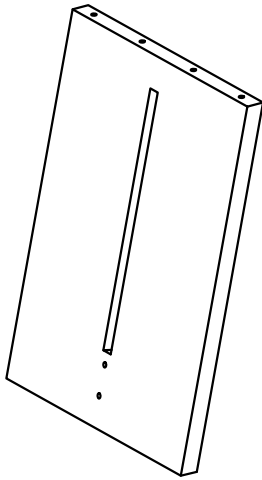

LEG (2 pcs)

(D)



STRETCHER (1 pc)

ASSEMBLY INSTRUCTION

ITEM NO.N715P194626

Hardware List

①

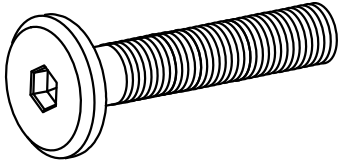

Ø 5/16" x 35 mm

BOLT (20 pcs)

②

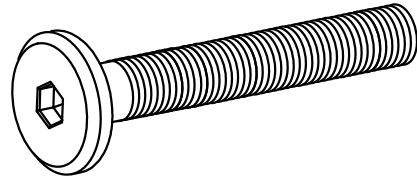

Ø 5/16" x 50 mm

BOLT (4 pcs)

③

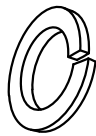

Ø5/16" x 13 mm

FLAT WASHER (24 pcs)

④

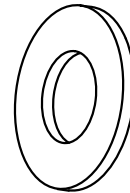

Ø5/16" x 19 mm

LOCK WASHER (12 pcs)

⑤



4 mm

ALLEN KEY (1 pc)

⑥







WOOD PLUG (4 pcs)

ASSEMBLY INSTRUCTION

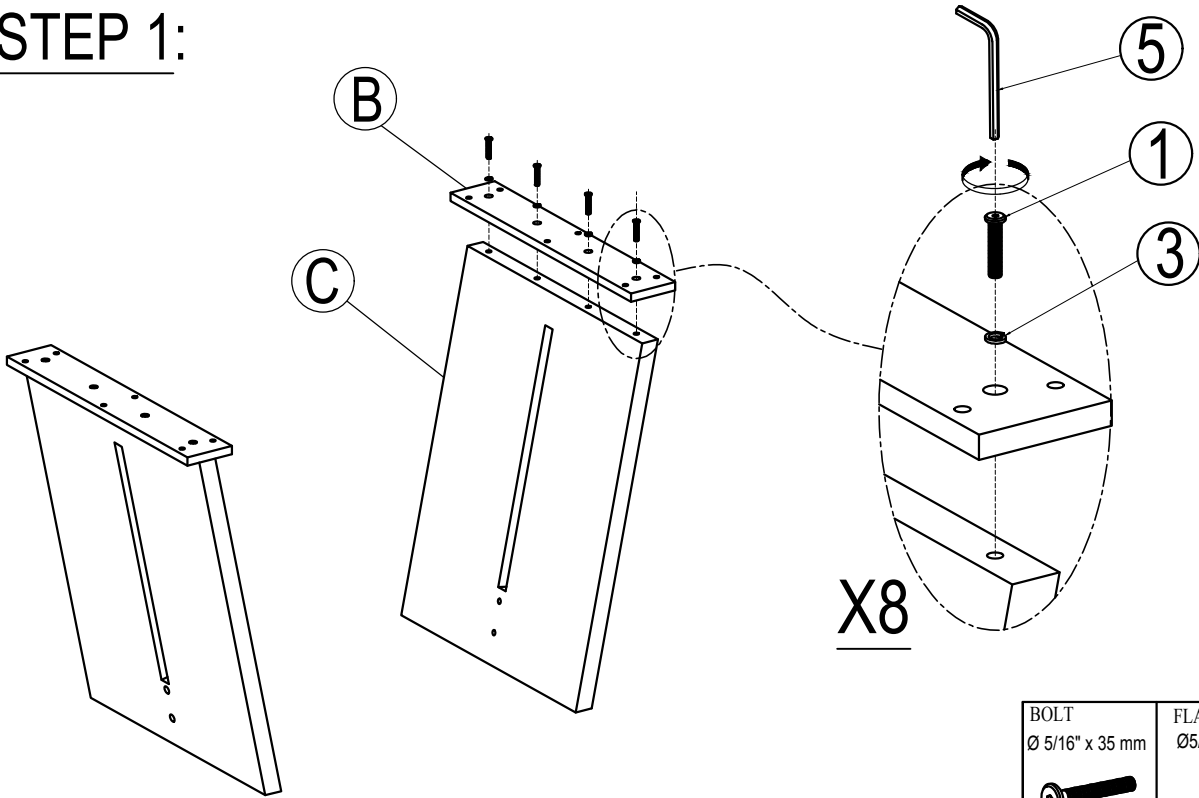
ITEM NO.N715P194626



STEP 1:

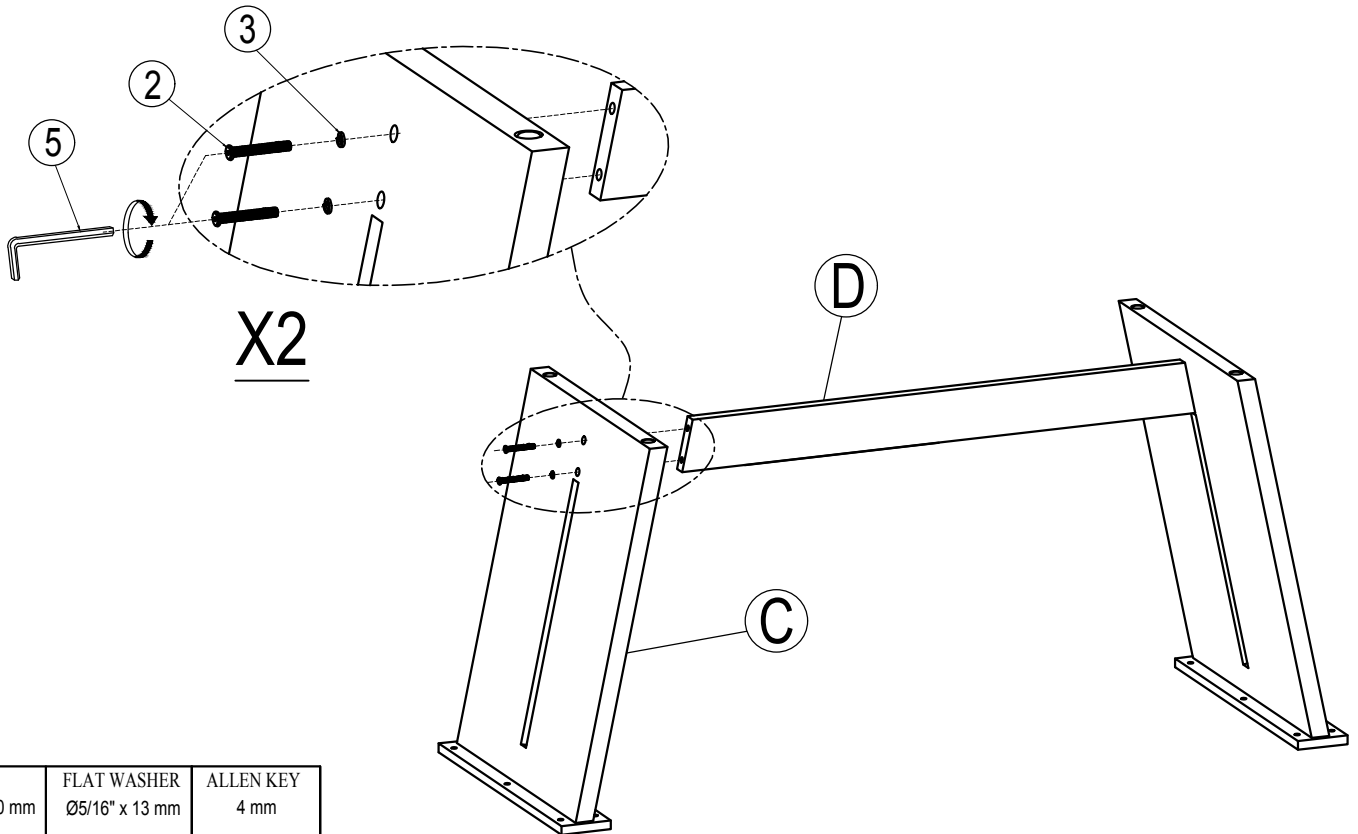

BOLT Ø 5/16" x 35 mm	FLAT WASHER Ø5/16" x 13 mm	ALLEN KEY 4 mm
		
① x 8	③ x 8	⑤ x 1

STEP 2:







BOLT Ø 5/16" x 50 mm	FLAT WASHER Ø5/16" x 13 mm	ALLEN KEY 4 mm
		
② x 4	③ x 4	⑤ x 1

ASSEMBLY INSTRUCTION

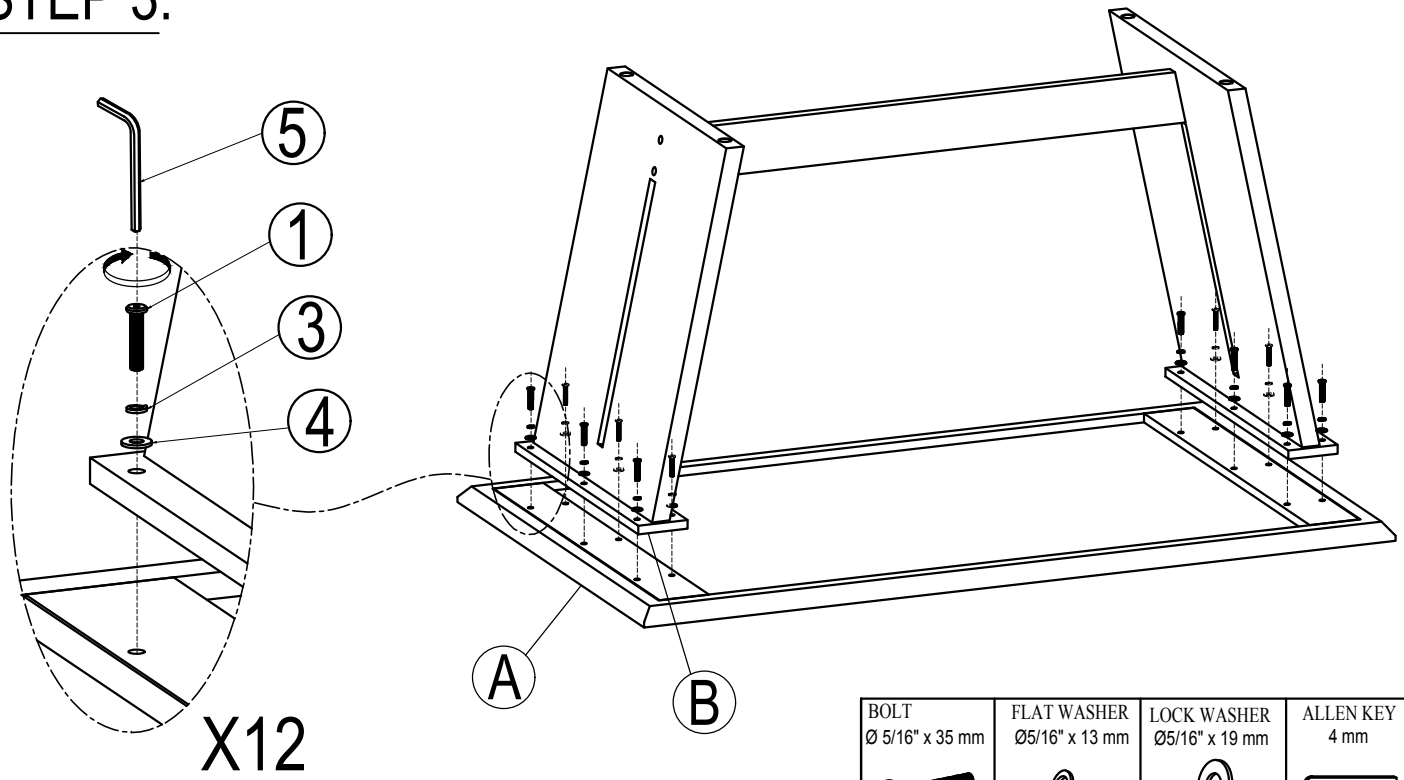
ITEM NO.N715P194626

STEP 3:

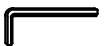

BOLT Ø 5/16" x 35 mm	FLAT WASHER Ø5/16" x 13 mm	LOCK WASHER Ø5/16" x 19 mm	ALLEN KEY 4 mm
			
① x 12	③ x 12	④ x 12	⑤ x 1

COMPLETE

