

Installation & Assembly

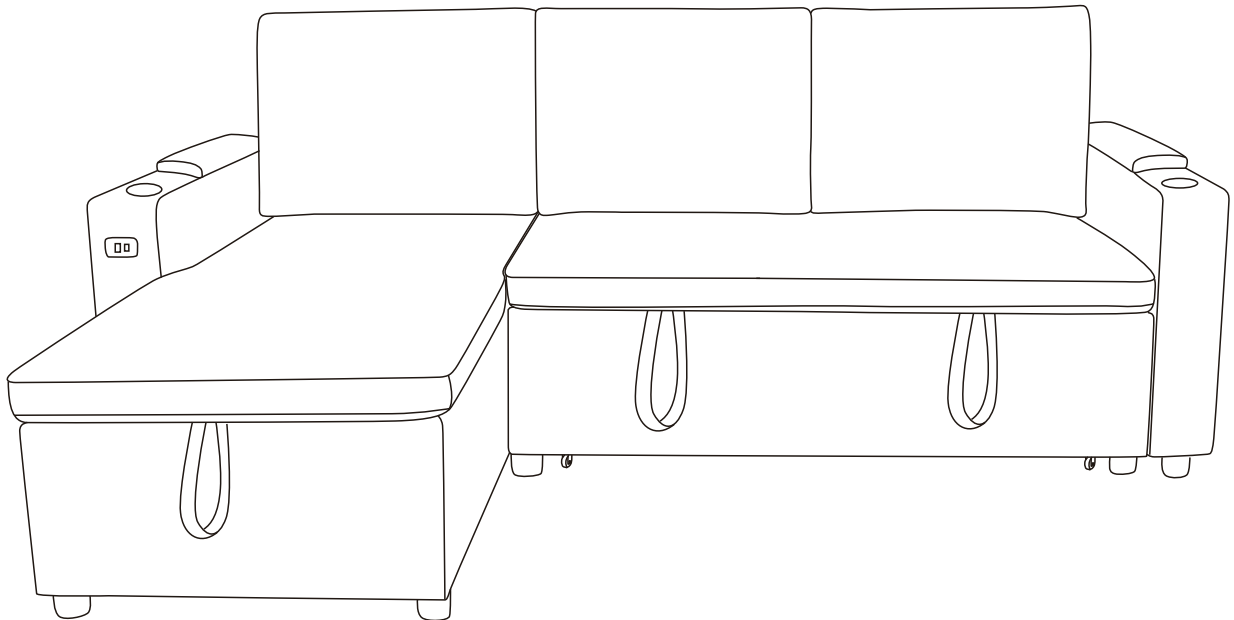
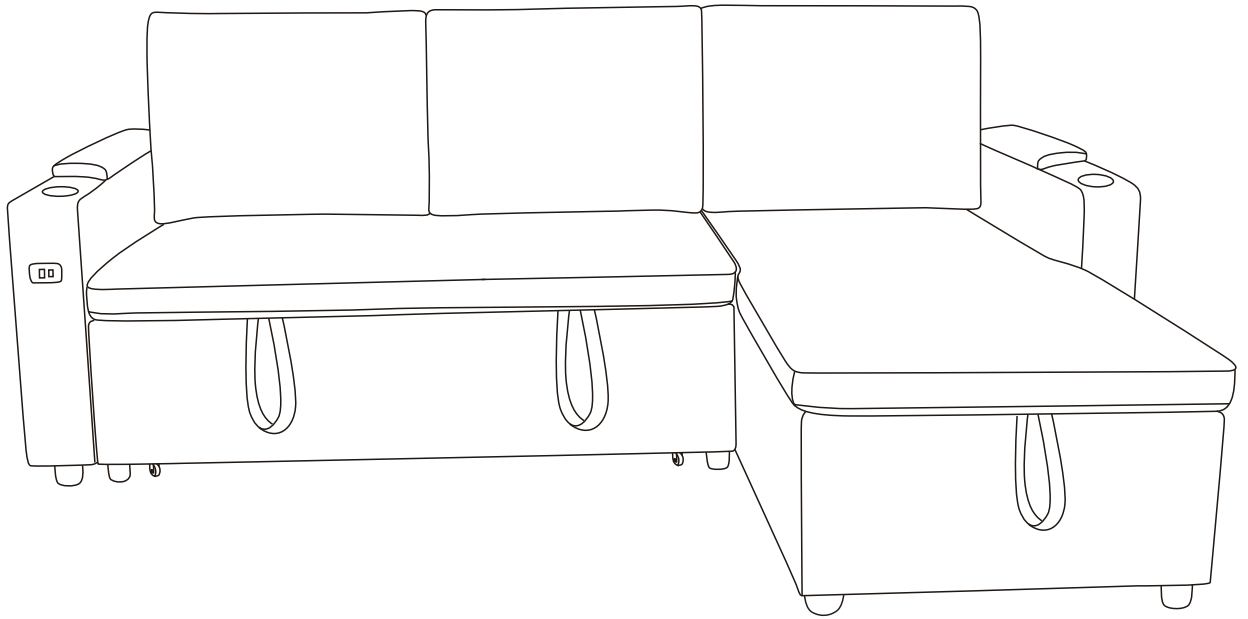

Carton:A

PARTS LIST

A

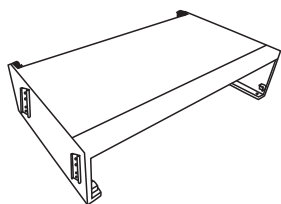

1PC

B

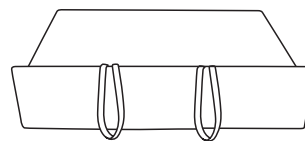

1PC

C

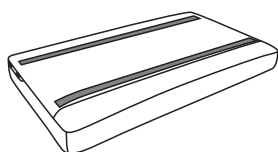

1PC

D



1PC

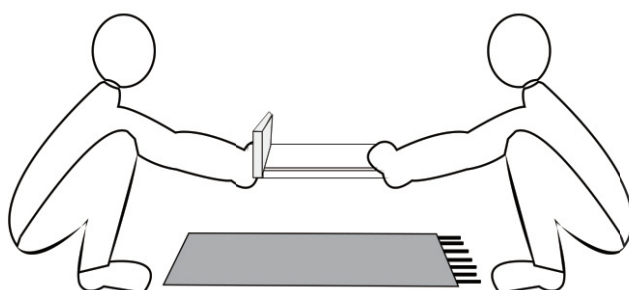

E

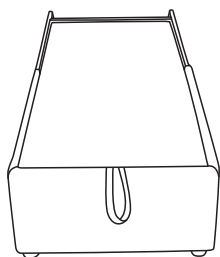

1PC

F



1PC

G

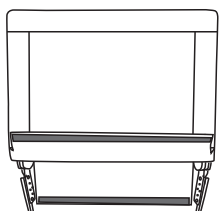

1PC

K

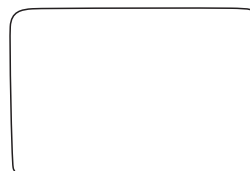

1PC

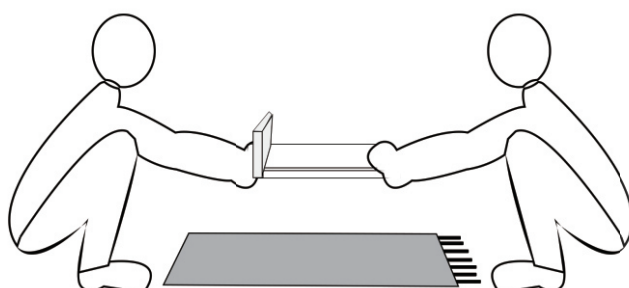

Carton:C

PARTS LIST

H-R

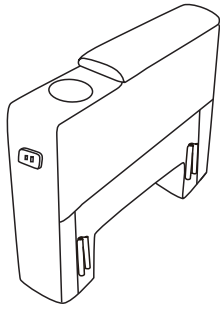

1PC

H-L

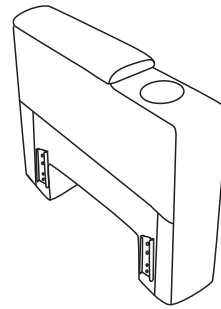

1PC

I

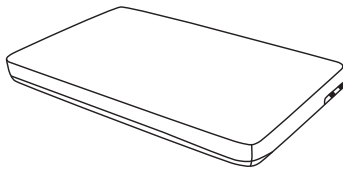

1PC

J

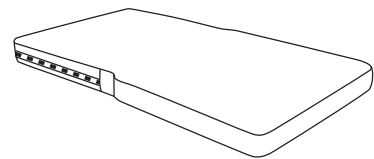

1PC

D



1PC

ACCESSORIES LIST

①



12PCS

②



4PCS

③



1PC

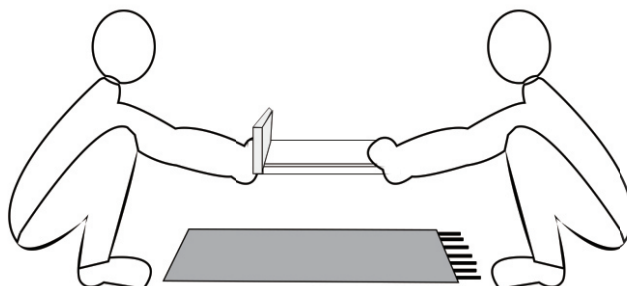

1

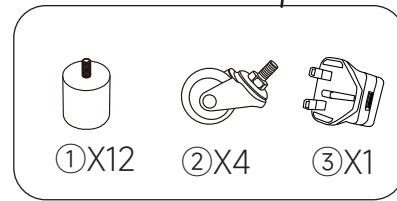
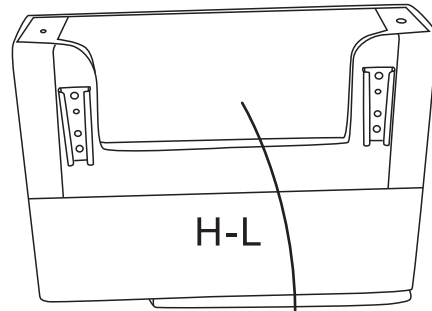
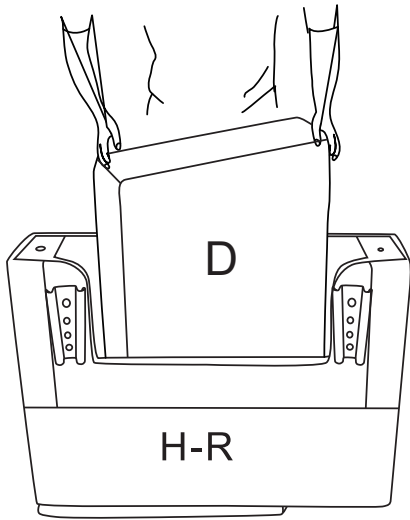

2

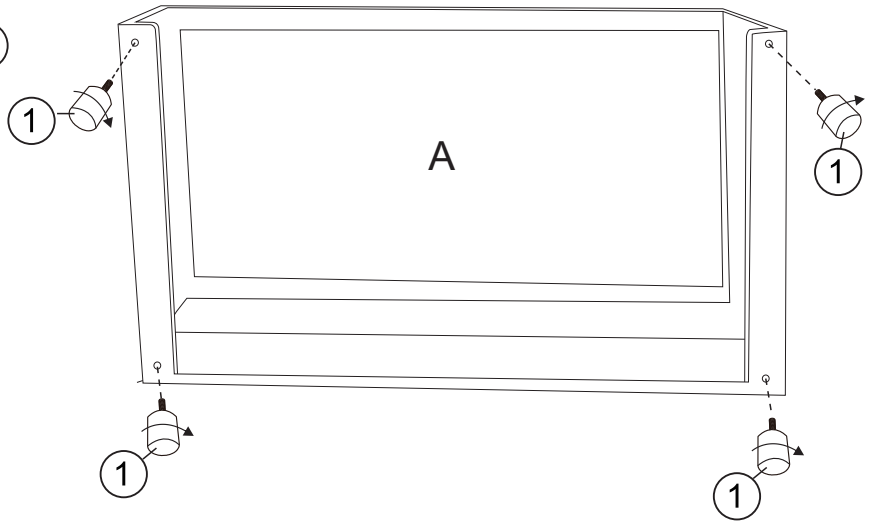
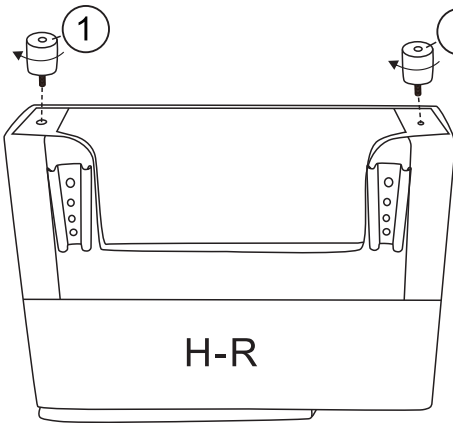

The front zip tie needs to be cut off before use.

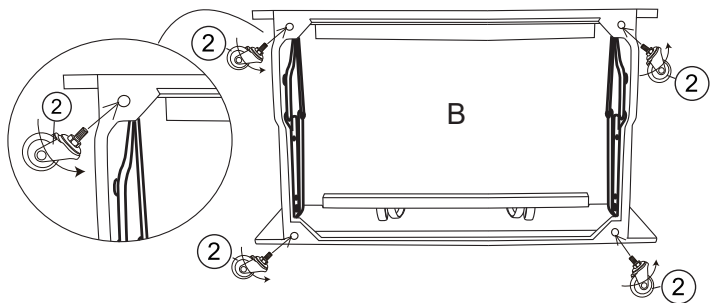
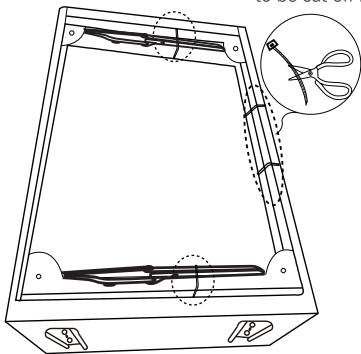

①		X6
②		X4

3

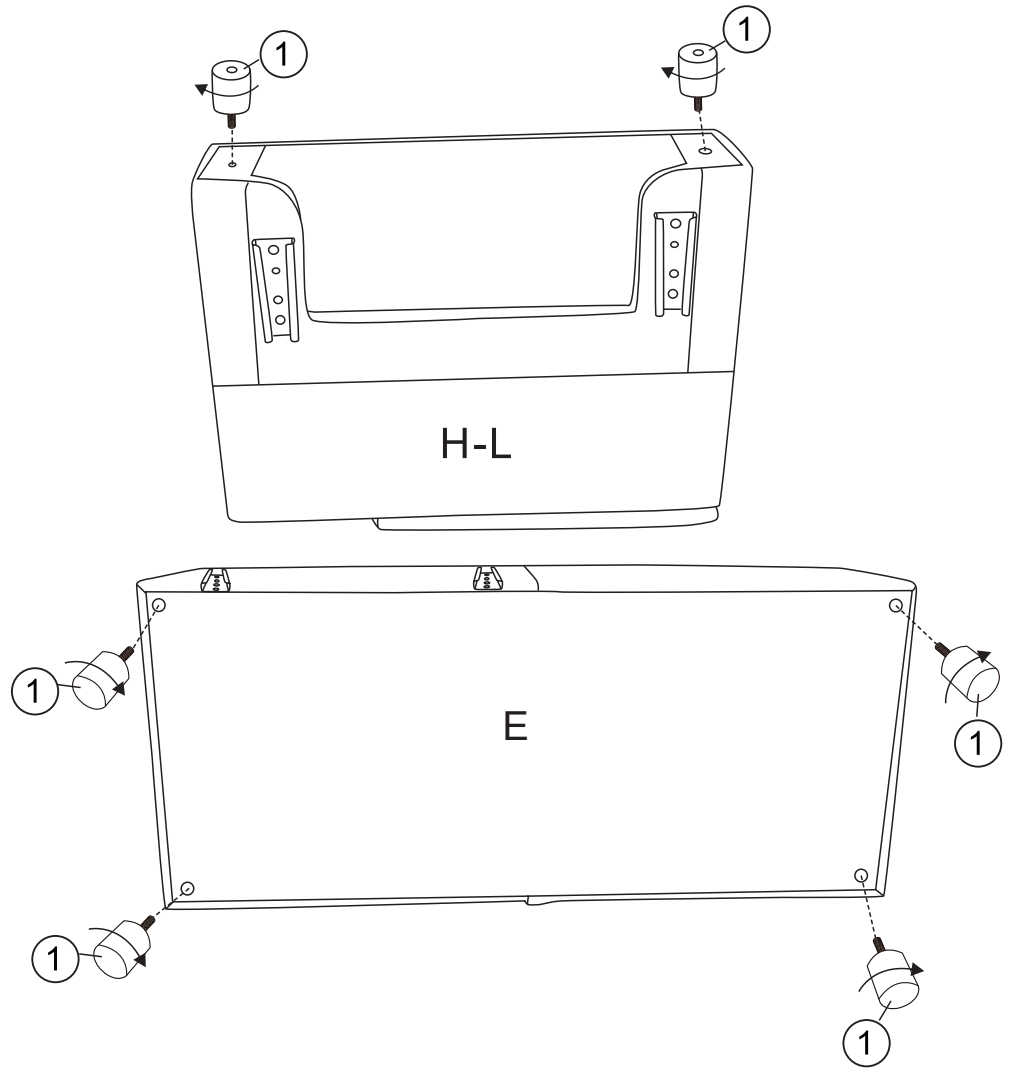

1		X6
---	---	----

4

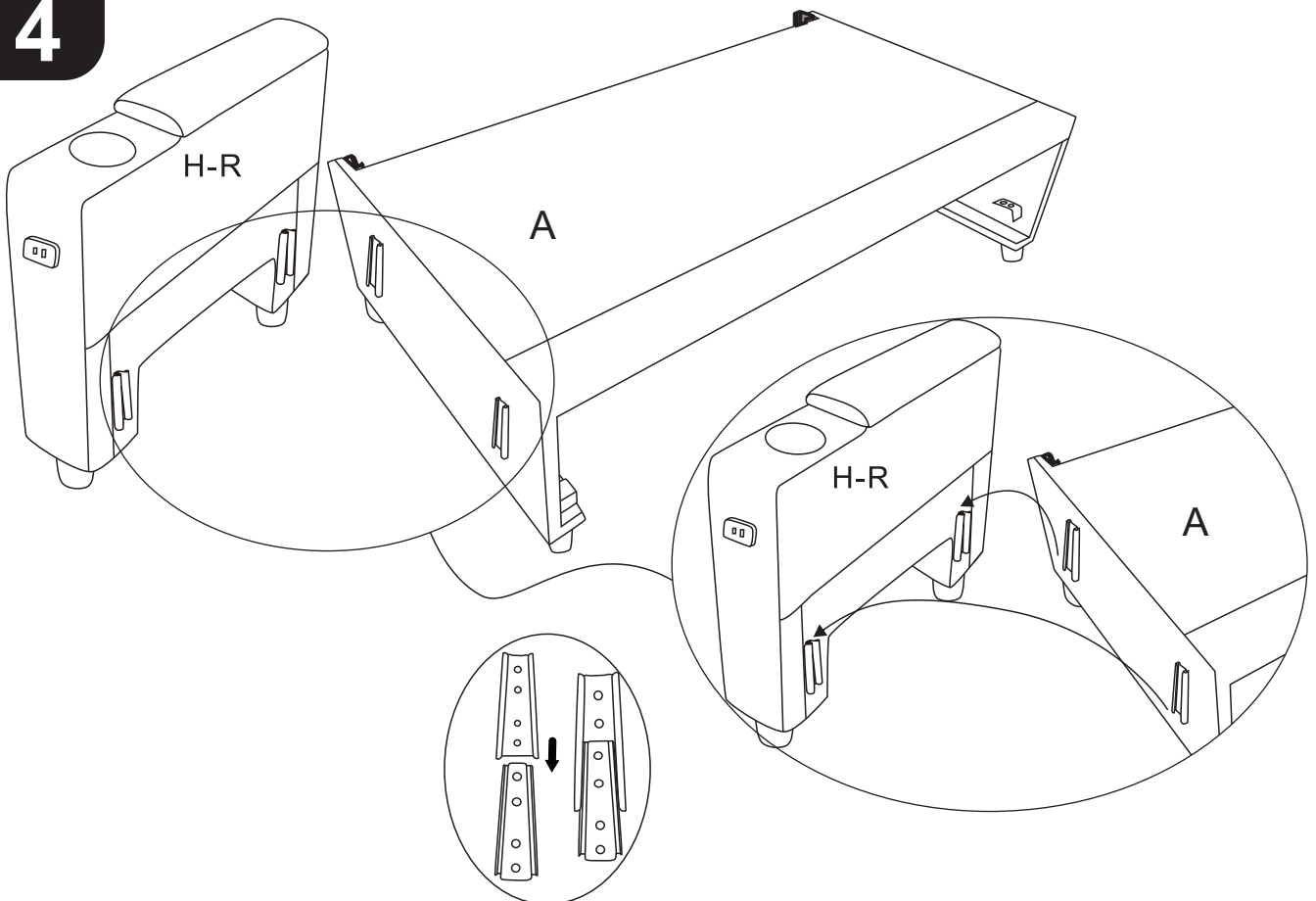

5

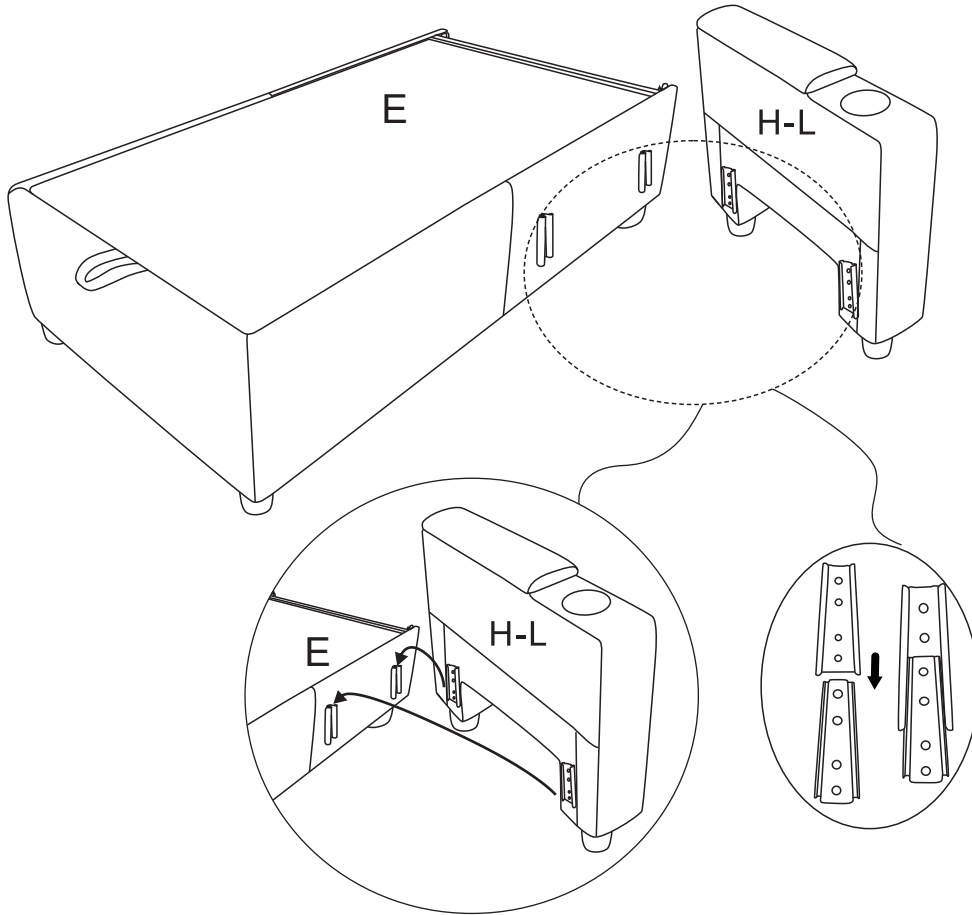

6

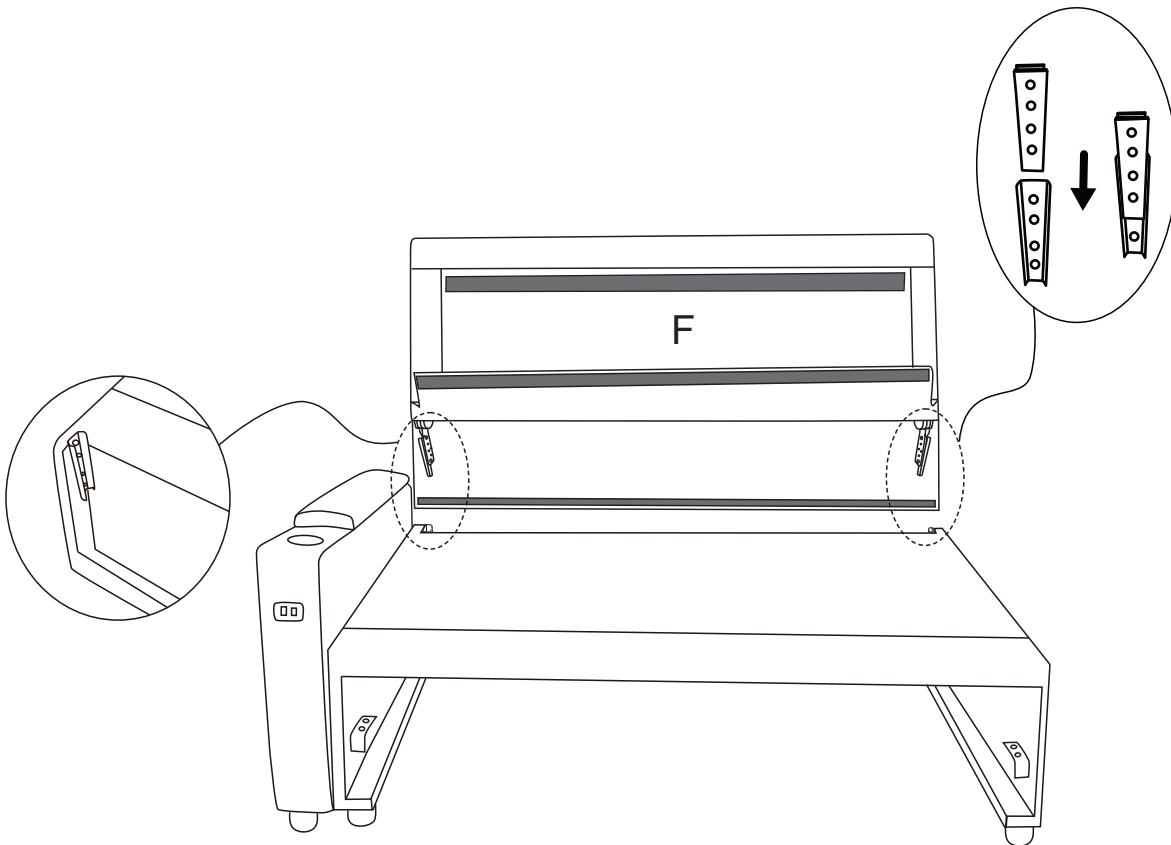

7

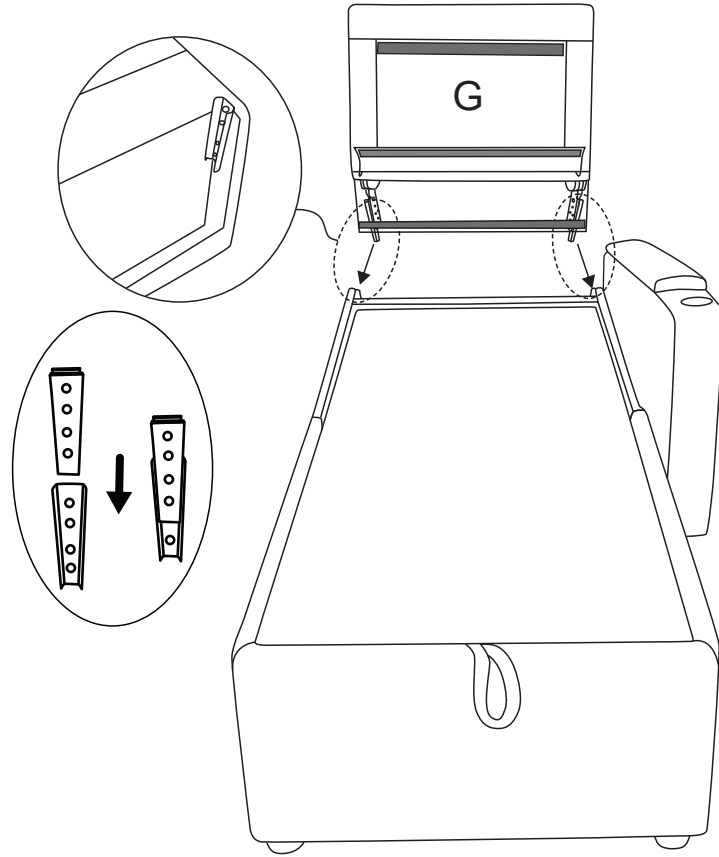

8

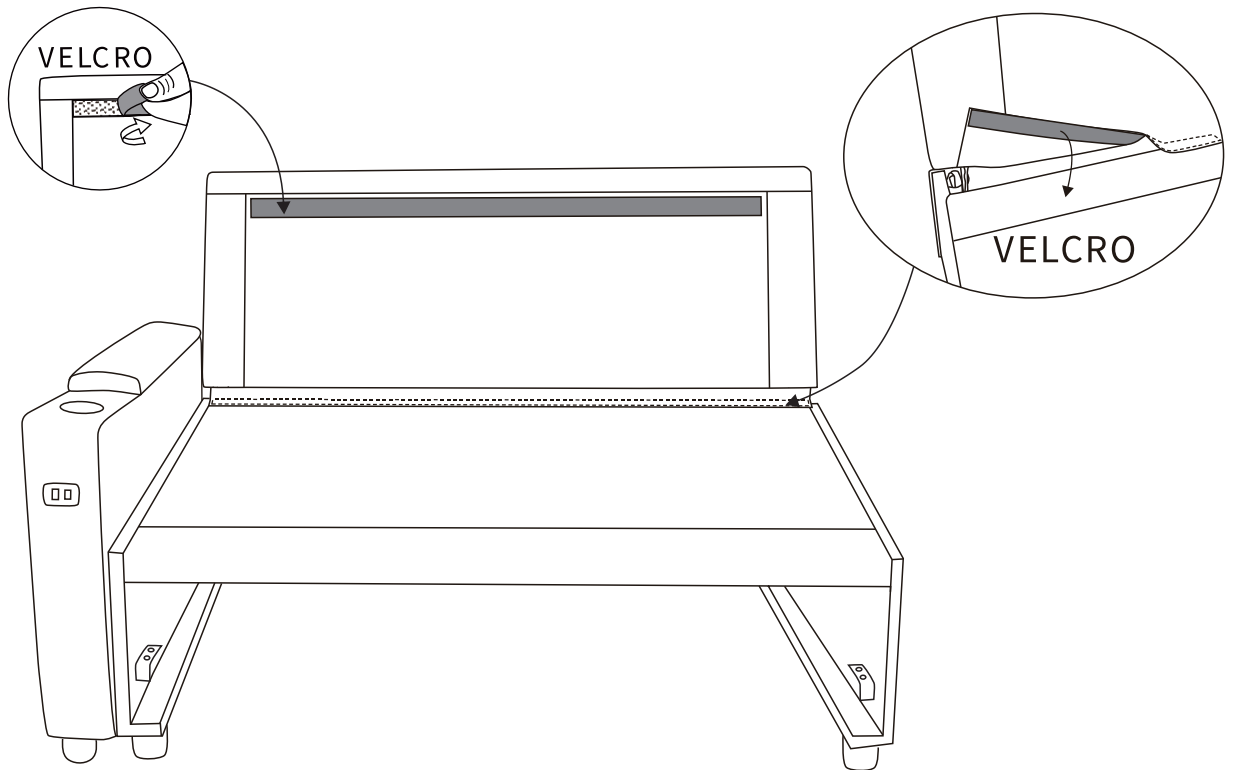

9

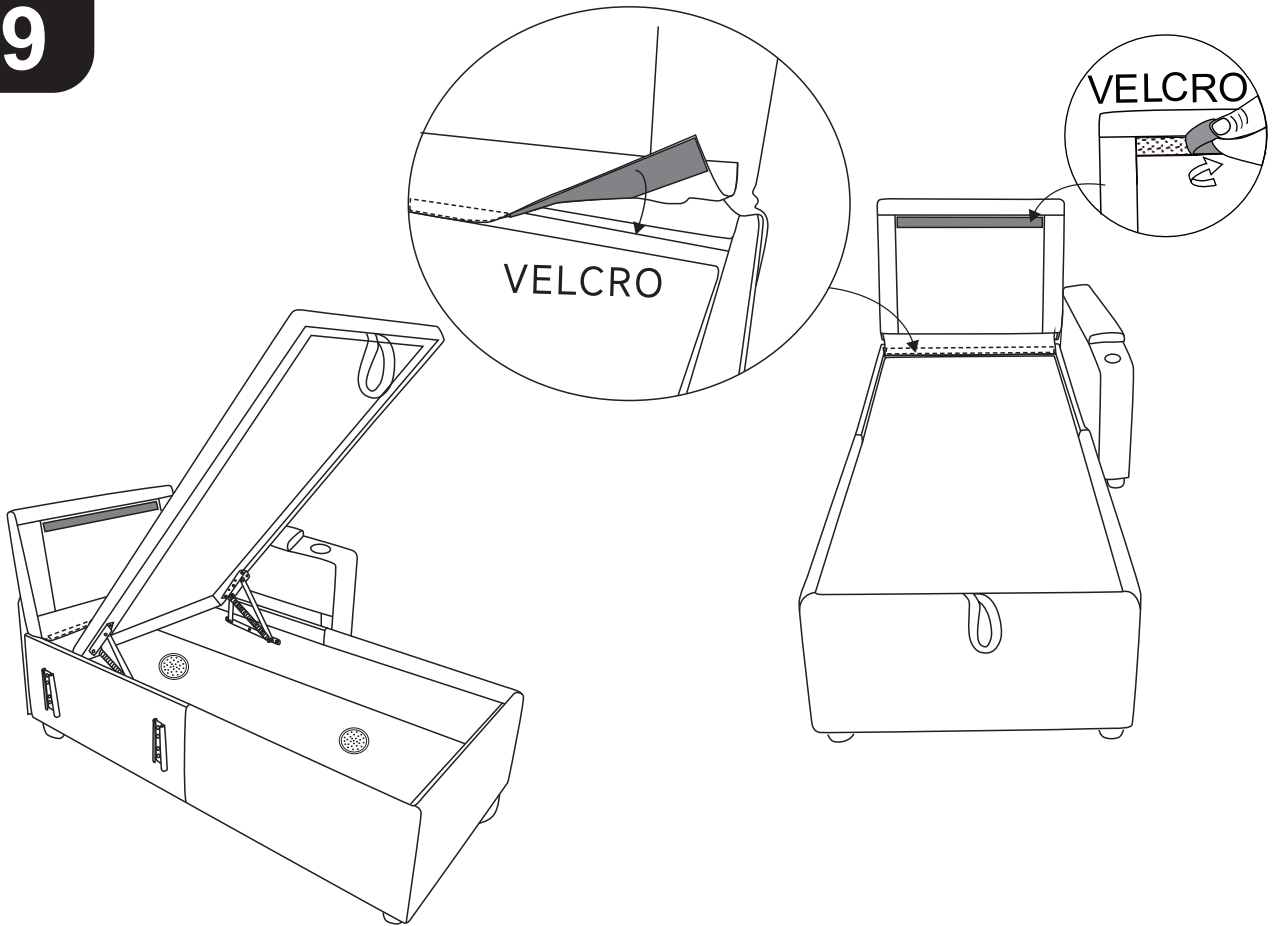

10

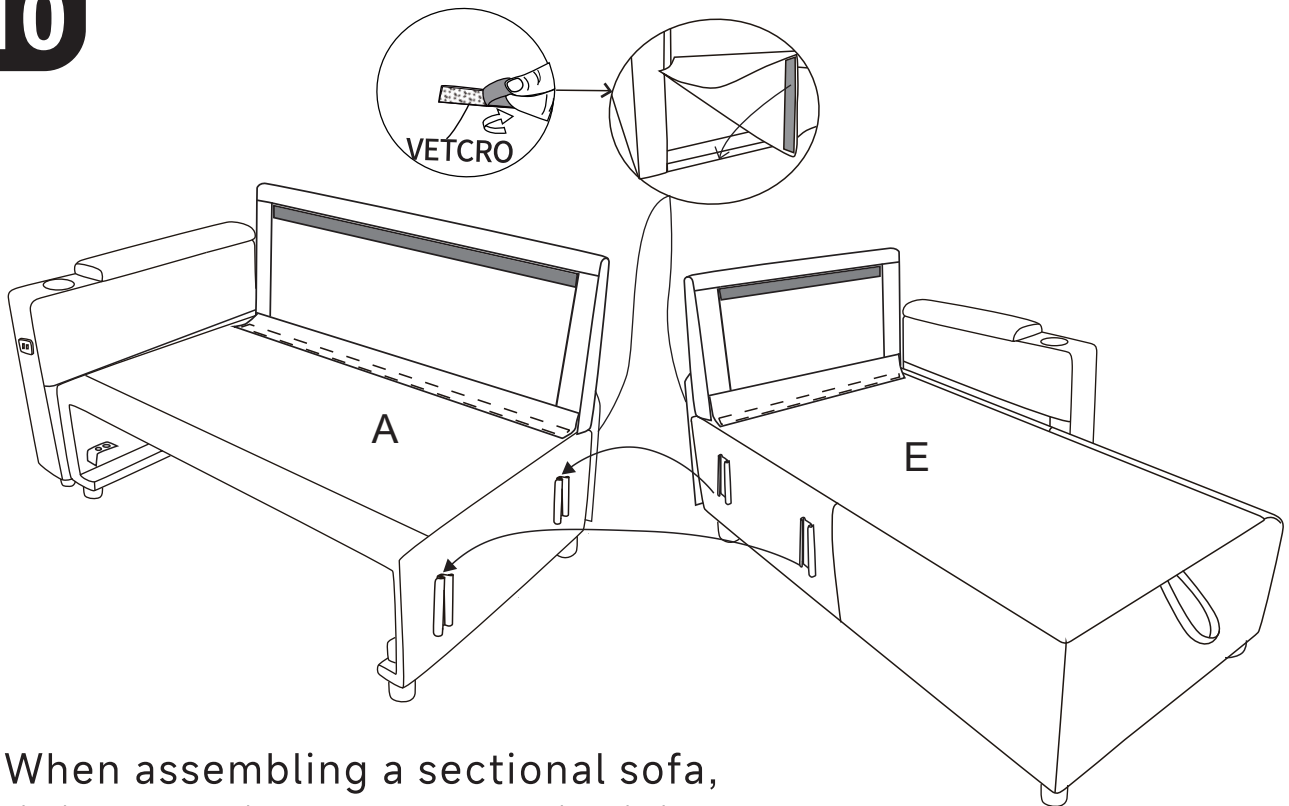

When assembling a sectional sofa, it is essential to have one individual positioned at the rear and another at the front, simultaneously lifting the sofa to securely fasten the components together.

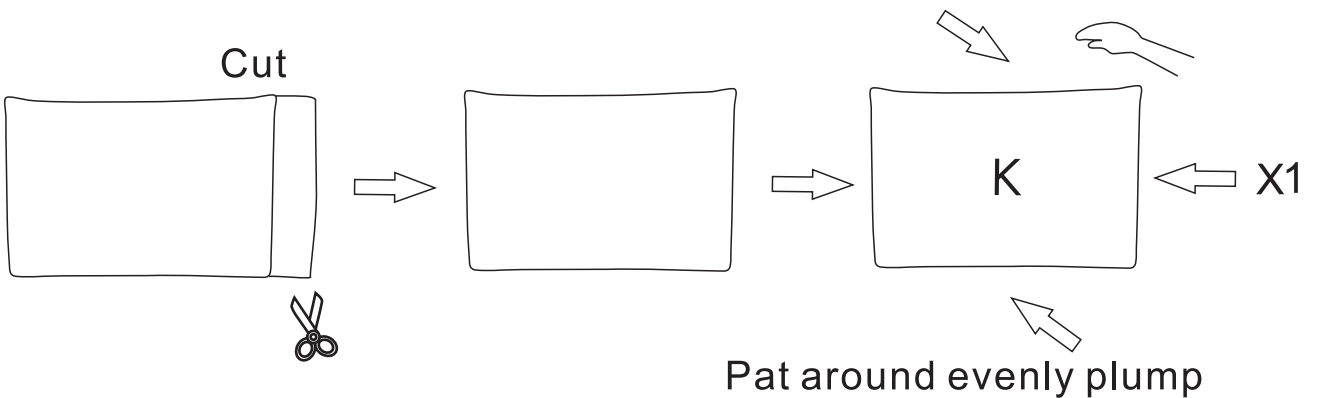
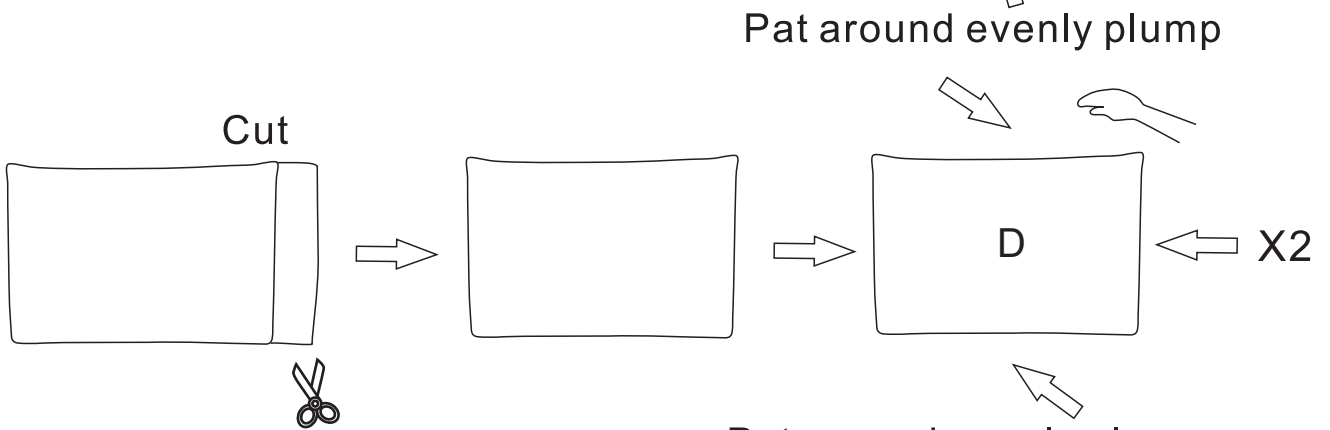
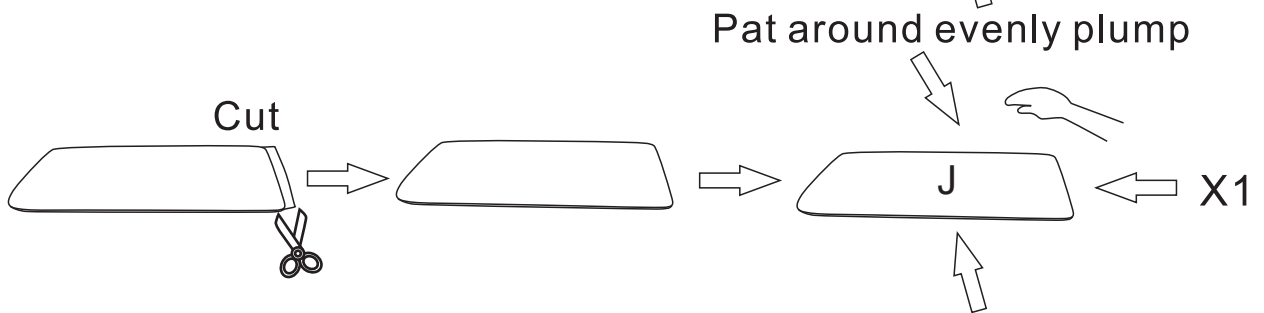
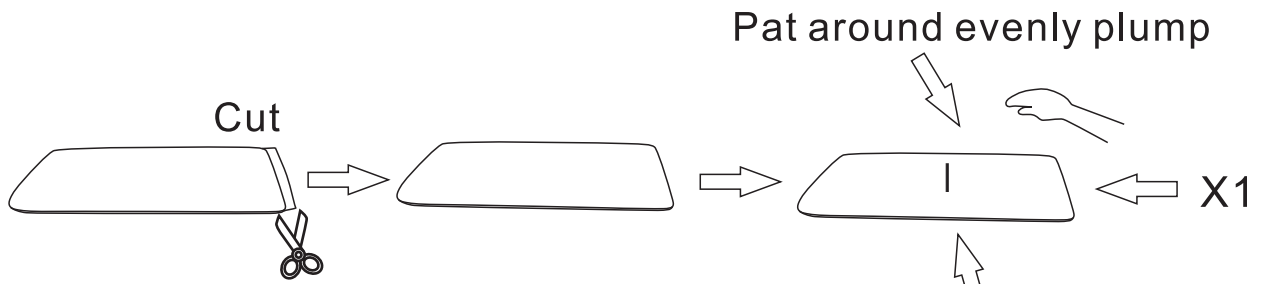

12

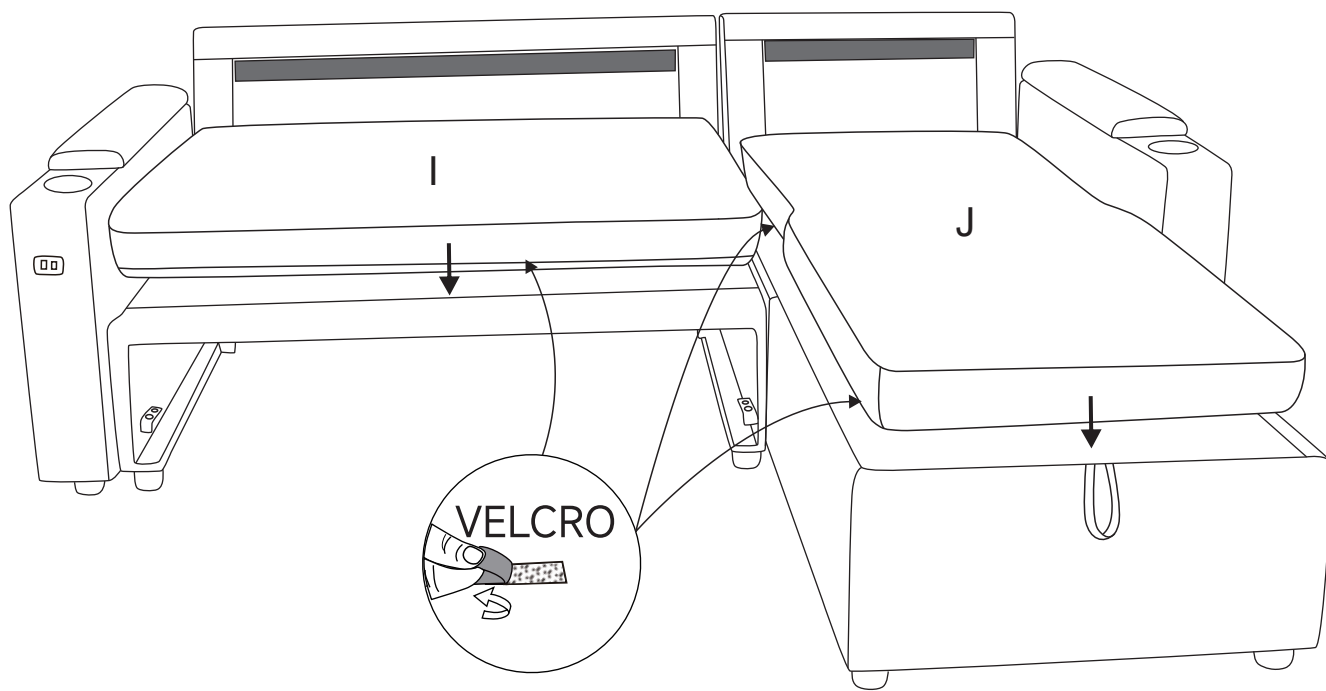

13

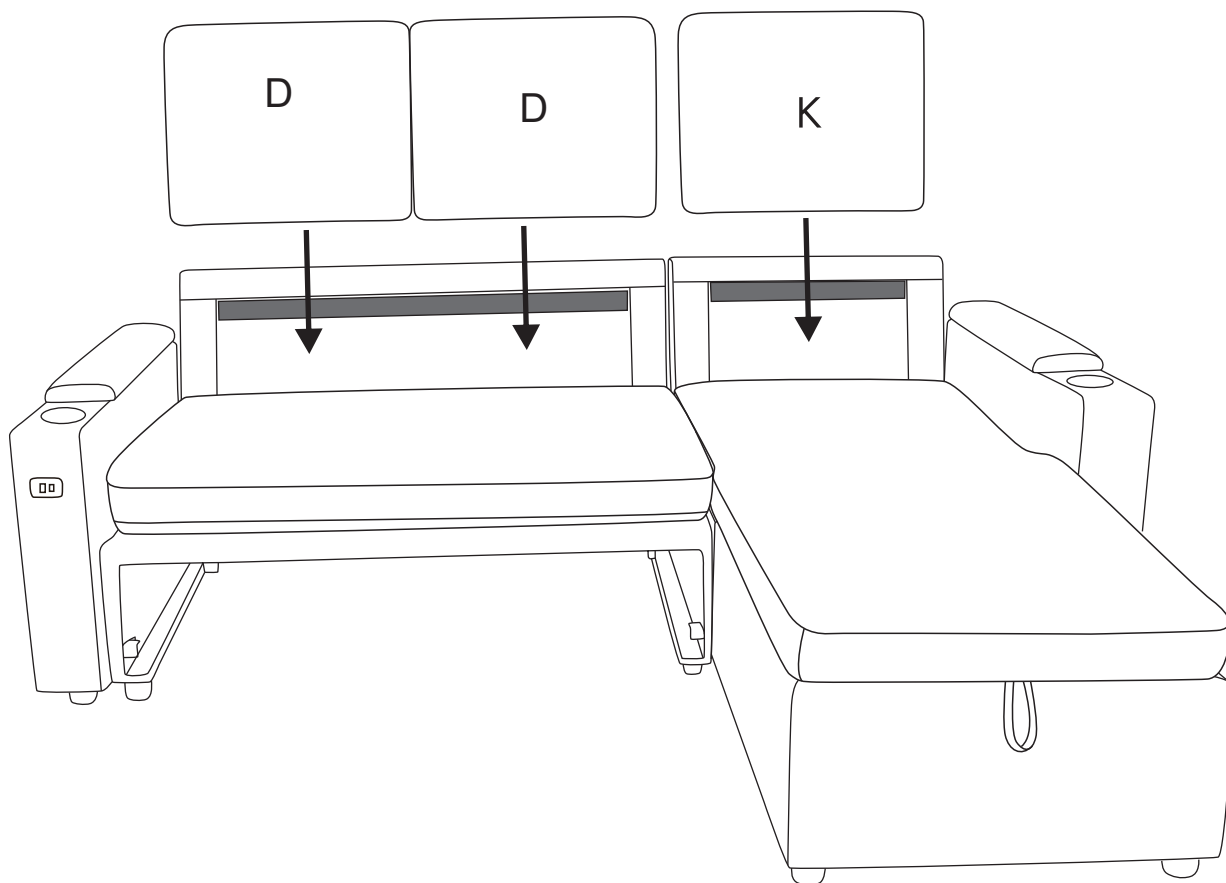

14

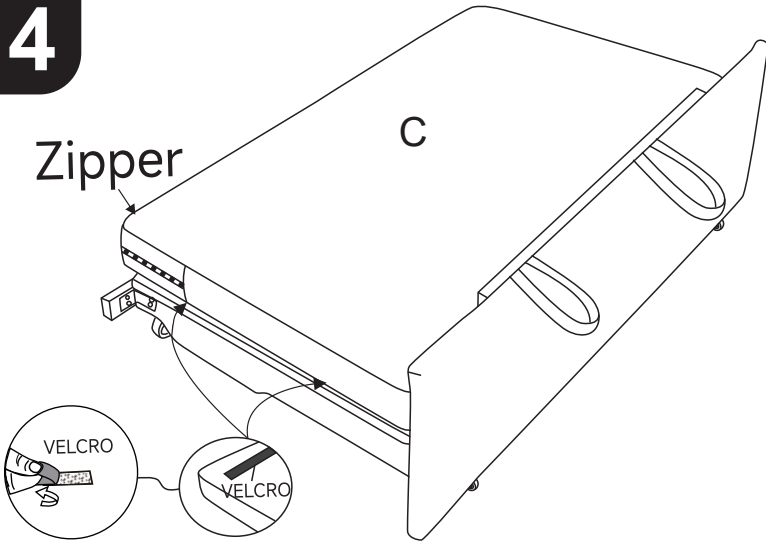

The cushion is in compression package . Just take out and plump up for hours . 48 hours is better for reaching its full size . Follow the assembly instructions to assemble after reach its full size .

15

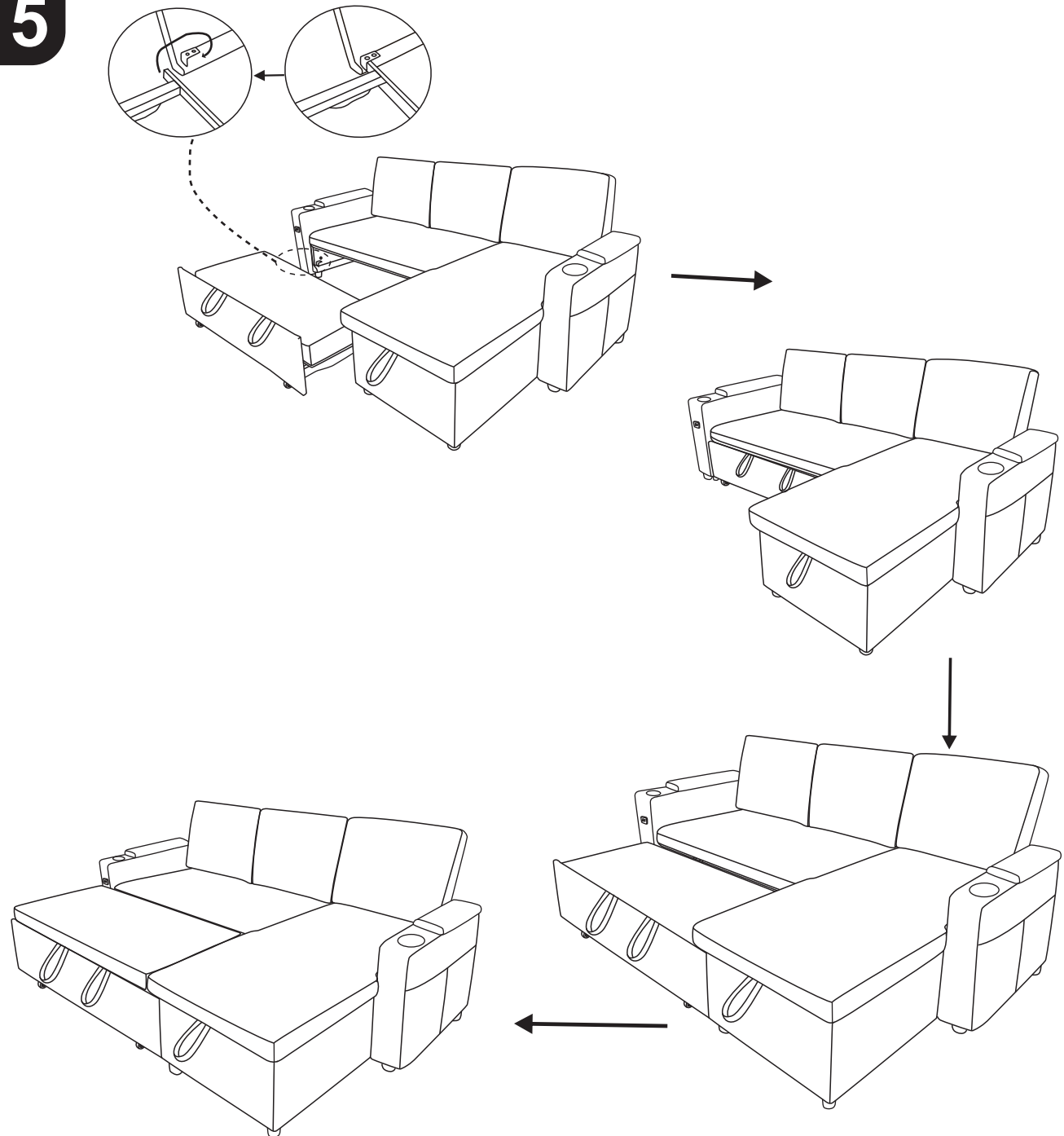

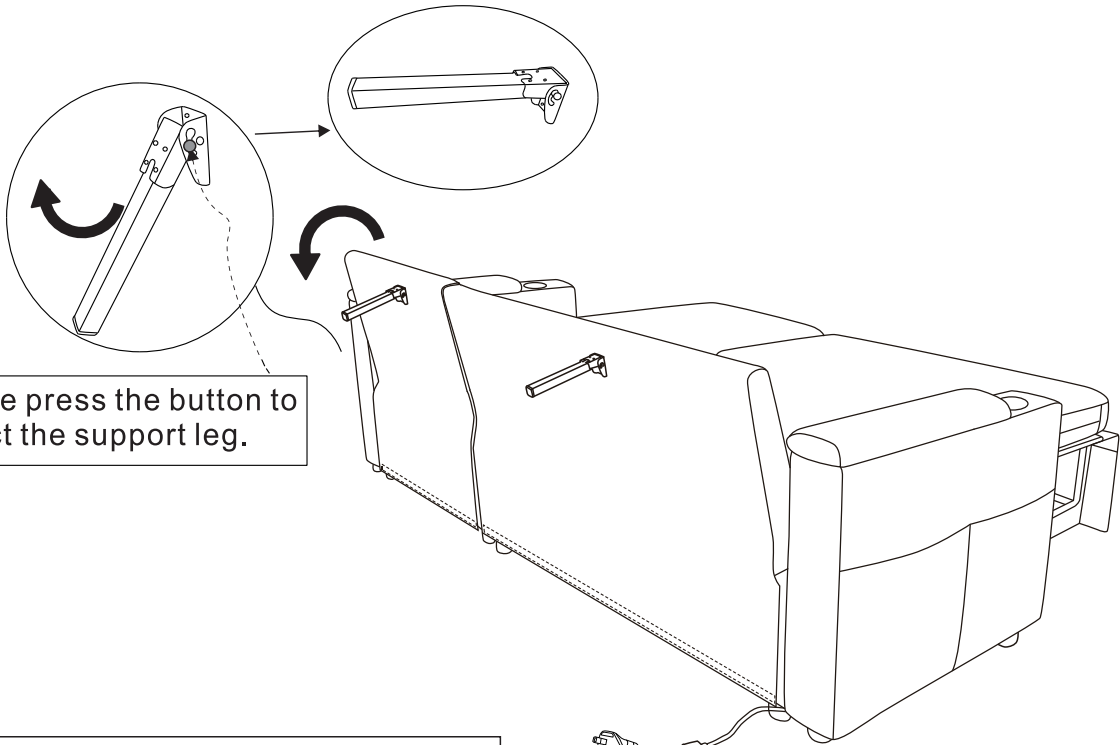

Please press the button to retract the support leg.

Please connect the armrest plug board to the power cord.

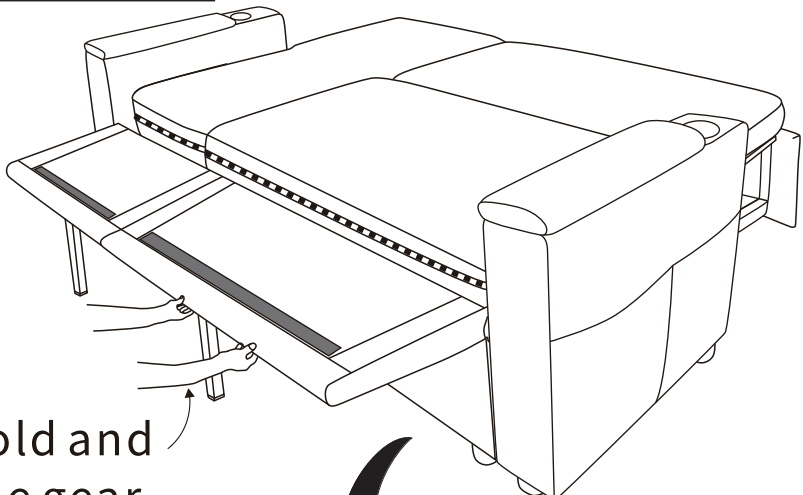

Please hold and adjust the gear with both hands.

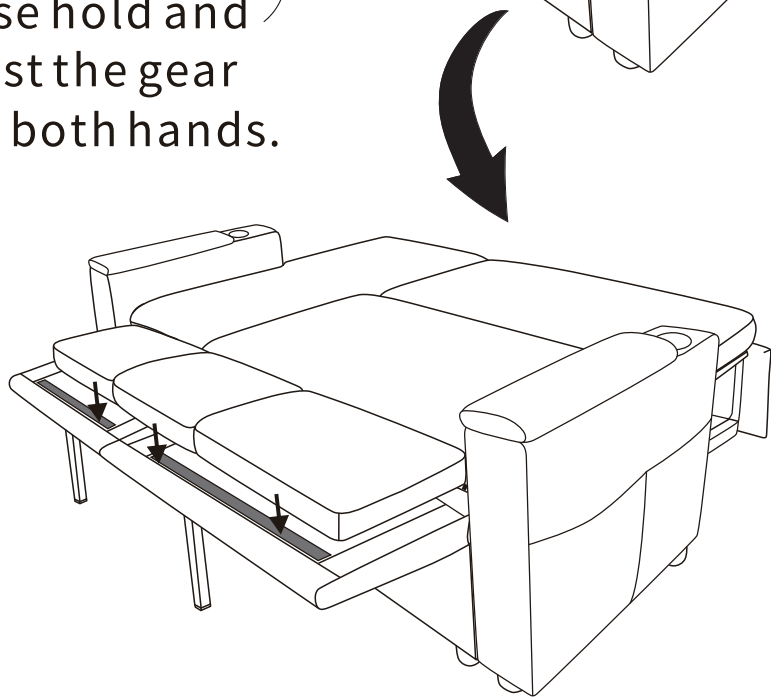

17

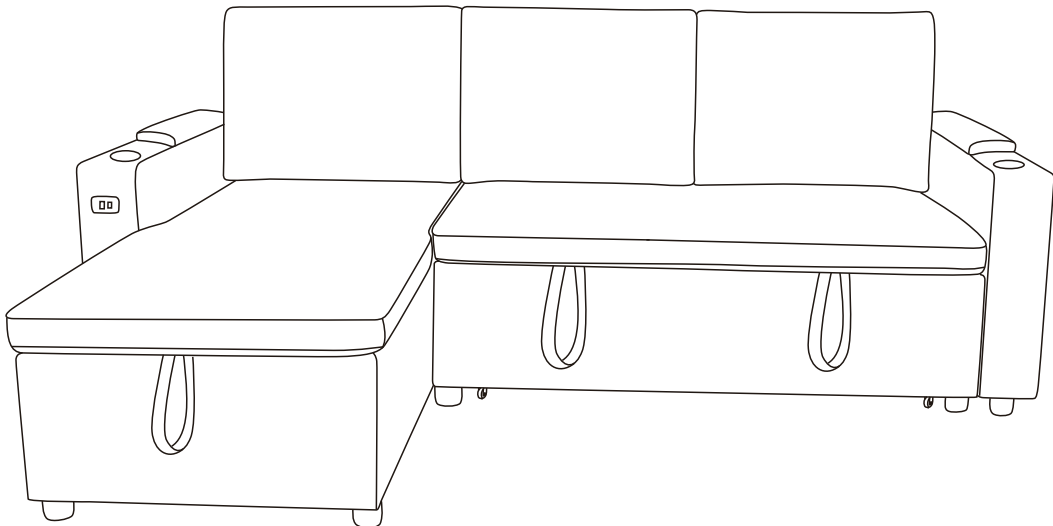
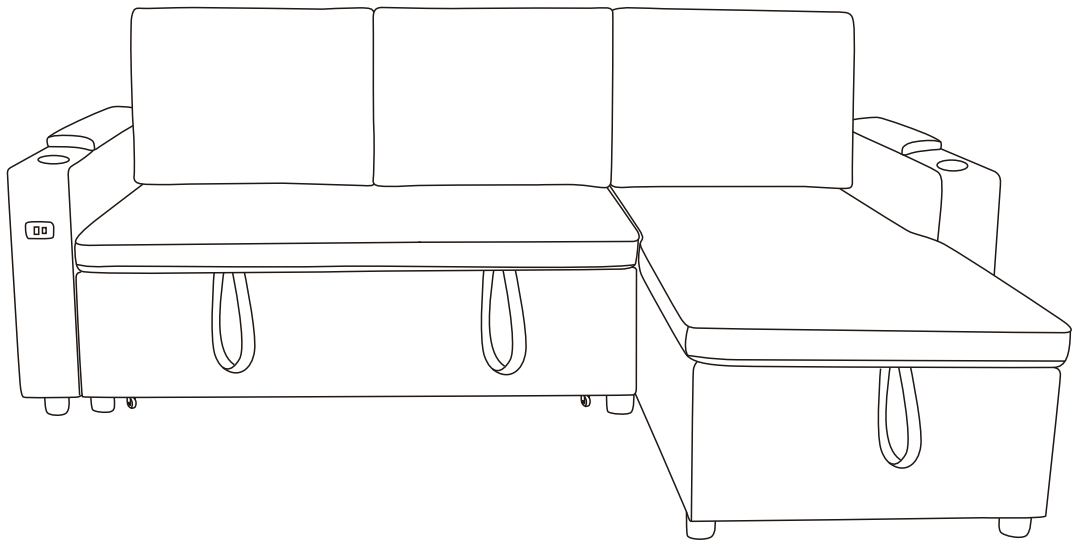
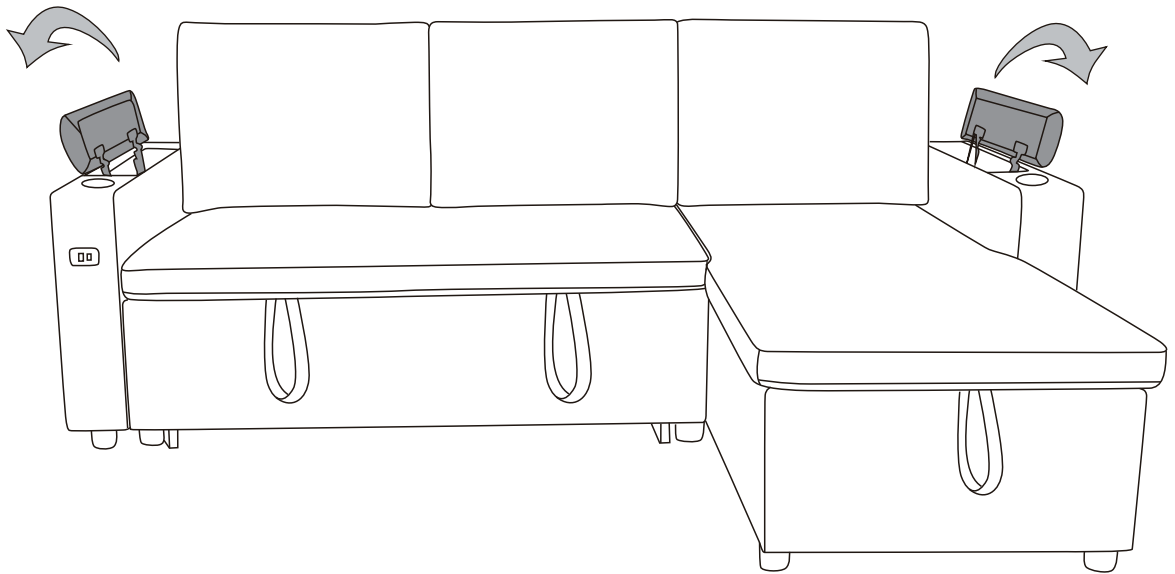

NOTICE

EN

1. Please do not exceed the weight limits of this item.
2. Firmly secure all bolts, screws and knobs before use.
3. Reconfirm that all bolts, screws and knobs are secure after every 90 days.
4. Fasten screws loosely during initial assembly. Do not tighten the screws firmly until the item is assembled completely.
5. Do not use or store this item in the proximity of an open flame or flammable chemicals.
6. If any part is missing, broken, damaged, or worn, stop using this product until repairs are made and or factory replacement parts are installed.
7. Do not use this item in any manner inconsistent with the manufacturer's instruction as this could void the product's warranty.

FR

1. Veuillez ne pas dépasser le poids recommandé.
2. Veuillez vous assurer que toutes les vis et écrous sont bien serrés avant la première utilisation.
3. Veuillez resserrer régulièrement toutes les vis et écrous pour prolonger la durée de vie du produit.
4. Lors de la première installation, veuillez ne pas serrer complètement les vis et les écrous. Après avoir terminé toutes les étapes d'installation, veuillez serrer toutes les vis et écrous uniformément.
5. N'utilisez pas le produit à proximité de flammes nues ou de matériaux inflammables.
6. Si vous constatez que les accessoires sont perdants, endommagés ou vieillissent, veuillez cesser immédiatement d'utiliser le produit jusqu'à ce que la réparation soit terminée ou que les accessoires d'origine soient utilisés pour terminer le remplacement.
7. Veuillez utiliser le produit conformément aux instructions du fabricant, sinon cela affectera la durée de vie du produit et invalidera la garantie du produit.

DE

1. Bitte überschreiten Sie nicht das empfohlene Gewicht.
2. Bitte stellen Sie vor dem ersten Gebrauch sicher, dass alle Schrauben und Muttern fest angezogen sind.
3. Ziehen Sie alle Schrauben und Muttern regelmäßig wieder an, um die Lebensdauer des Produkts zu verlängern.
4. Bitte ziehen Sie die Schrauben und Muttern während der Erstinstallation nicht vollständig an. Ziehen Sie nach Abschluss aller Installationsschritte alle Schrauben und Muttern gleichmäßig an.
5. Verwenden Sie das Produkt nicht in der Nähe von offenen Flammen oder brennbaren Materialien.
6. Wenn Sie feststellen, dass das Zubehör fehlt, beschädigt ist oder altert, stellen Sie die Verwendung des Produkts sofort ein, bis die Reparatur abgeschlossen ist oder das Originalzubehör zum Abschluss des Austauschs verwendet wird.
7. Bitte verwenden Sie das Produkt gemäß den Anweisungen des Herstellers. Andernfalls wird die Lebensdauer des Produkts beeinträchtigt und die Produktgarantie erlischt.

NOTICE

ES

1. No utilice más del peso recomendado.
2. Asegúrese de que todos los tornillos y tuercas estén completamente apretados antes del uso inicial.
3. Vuelva a apretar todos los tornillos y tuercas regularmente para prolongar la vida útil del producto.
4. No apriete completamente los tornillos y tuercas durante la instalación inicial, y apriete todos los tornillos y tuercas uniformemente después de que se completen todos los pasos de instalación.
5. No utilice el producto cerca de llamas abiertas o materiales inflamables.
6. Si se encuentra que falta algún accesorio, está dañado o envejece, deje de usar el producto inmediatamente hasta que se complete la reparación o se realice el reemplazo con la pieza original.
7. Siga las instrucciones del fabricante para utilizar el producto, de lo contrario afectará a la vida útil del producto y invalidará la garantía del producto.

IT

1. Si prega di non superare il peso consigliato.
2. Assicurarsi che viti e dadi (tutti) siano completamente serrati prima dell'utilizzo.
3. Verificare regolarmente (ogni 90 giorni) che viti e dadi siano ben serrati.
4. Si prega di non serrare completamente viti e dadi durante l'installazione iniziale. Solamente dopo aver completato tutti i passaggi di installazione, serrare viti e dadi in modo uniforme.
5. Non utilizzare il prodotto vicino a fiamme libere o materiali infiammabili.
6. Se qualche pezzo risulta danneggiato, rotto, consumato o mancante, fermare immediatamente l'utilizzo del prodotto e procedere alla relativa sostituzione con ricambi originali.
7. Per non compromettere la durata di vita del prodotto e/o perdere il diritto alla garanzia, utilizzare il prodotto seguendo le istruzioni del produttore.