

ASSEMBLY INSTRUCTIONS



VANITY

REVISION 0 : 07/22/2021
REVISION 1 : 10/11/2023
REVISION 2 : 09/02/2025

ASSEMBLY INSTRUCTIONS

ASSEMBLY TIPS:

1. Remove hardware from box and sort by size.
2. Please check to see that all hardware and parts are present prior to start of assembly.
3. Please follow attached instructions in the same sequence as numbered to assure fast & easy assembly.



WARNING!

1. Don't attempt to repair or modify parts that are broken or defective. Please contact the store immediately.
2. This product is for home use only and not intended for commercial establishments.



ASSEMBLY TIME 99 MINUTES

PARTS IDENTIFICATION

B2: VANITY BASE & GLASS

A BOTTOM PANEL

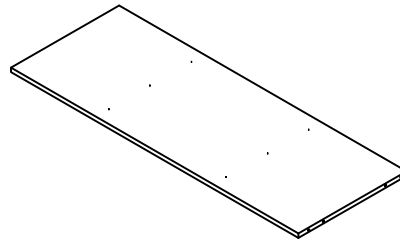

1PC

B BACK PANEL

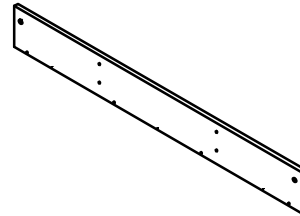

1PC

C LEFT PANEL

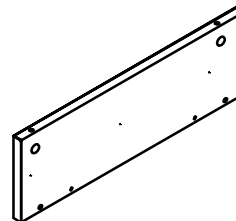

1PC

D MIDDLE PANEL

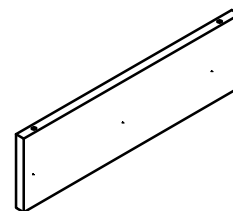

2PCS

ASSEMBLY INSTRUCTIONS

PARTS IDENTIFICATION

E

RIGHT PANEL

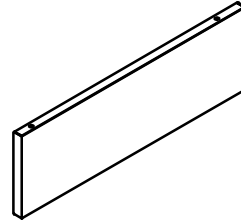

1PC

FN

SIDE DRAWER FRONT PANEL

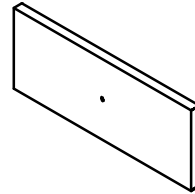

2PCS

G

MIDDLE DRAWER FRONT PANEL

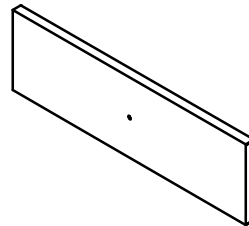

1PC

H

HANDLE



3PCS

I

DRAWER LEFT PANEL

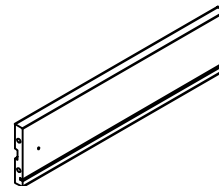

3PCS

ASSEMBLY INSTRUCTIONS

PARTS IDENTIFICATION

J DRAWER RIGHT PANEL 3PCS

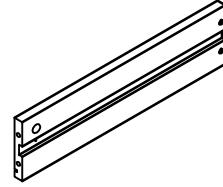

K SMALL DRAWER BACK PANEL 2PCS

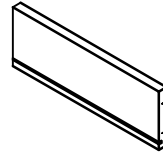

L LARGE DRAWER BACK PANEL 1PC

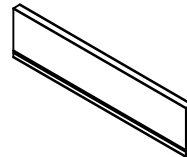

M SMALL DRAWER BOTTOM PANEL 2PCS

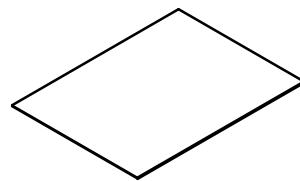

N LARGE DRAWER BOTTOM PANEL 1PC

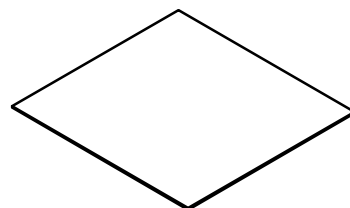

ASSEMBLY INSTRUCTIONS

PARTS IDENTIFICATION

O

TOP PANEL

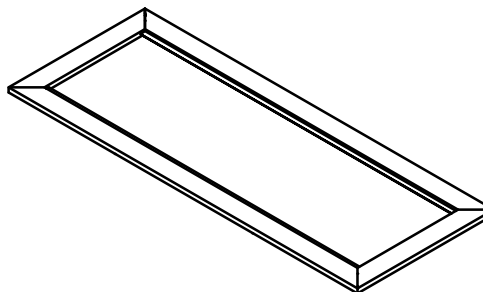

1PC

P

LEFT FRAME

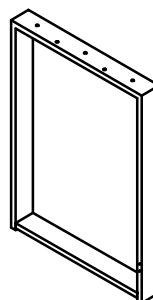

1PC

Q

RIGHT FRAME

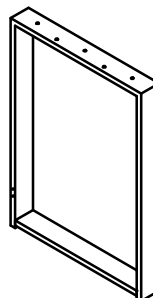

1PC

R

BACK FRAME

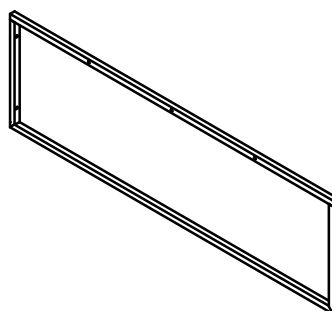

1PC

S

BOTTOM CROSSBAR

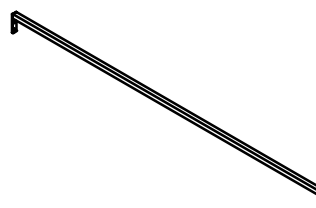

1PC

ASSEMBLY INSTRUCTIONS

PARTS IDENTIFICATION

T GLASS

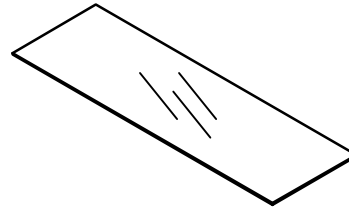

1PC

U SLIDE RAIL

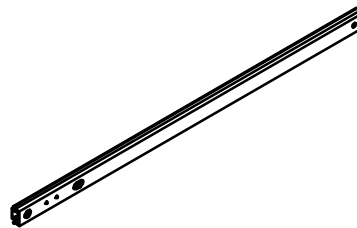

6PCS

B1: VANITY TOP

A1 MAKE-UP MIRROR

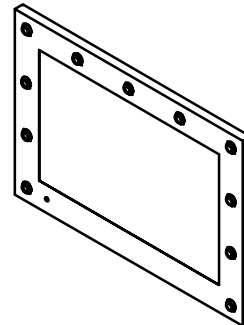

1PC

A2 CROSSBAR



2PCS

B3: 11PCS LIGHT BULB

A3 LIGHT BULB



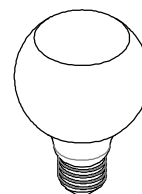









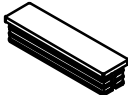



TYPE G / E26 CLEAR LIGHT BULB / 4 WATT.



11PCS

ASSEMBLY INSTRUCTIONS

HARDWARE IDENTIFICATION

1	SMALL CAP (15 x 30 mm BLK)		4PCS	11	LONG CAM BOLT (38mm SR)		12PCS
2	LARGE CAP (15 x 60 mm BLK)		4PCS	12	SHORT CAM BOLT (33mm SR)		8PCS
3	LONG BOLT (1/4" x 28mm SR)		17PCS	13	CAM-LOCK		20PCS
4	MEDIUM BOLT (1/4" x 25mm SR)		8PCS	14	DOWEL (8 x 30mm)		16PCS
5	SHORT BOLT (1/4" x 13mm SR)		4PCS	15	GLUE		1PC
6	BOLT (1/4" x 25mm SR)		2PCS	16	SUCTION CUP		8PCS
7	HANDLE BOLT (5/32" x 22mm SR)		3PCS	17	ALLEN WRENCH (4mm)		1PC
8	SLIDE RAIL BOLT (5/32" x 12mm SR)		6PCS				
9	SCREW (4 x 38mm)		20PCS				
10	SLIDE RAIL SCREW (3 x 12mm SR)		18PCS				

Hardware pack is located in 935934B2

ASSEMBLY INSTRUCTIONS

STEP 1 Do not tighten until each step is completed or instructed.

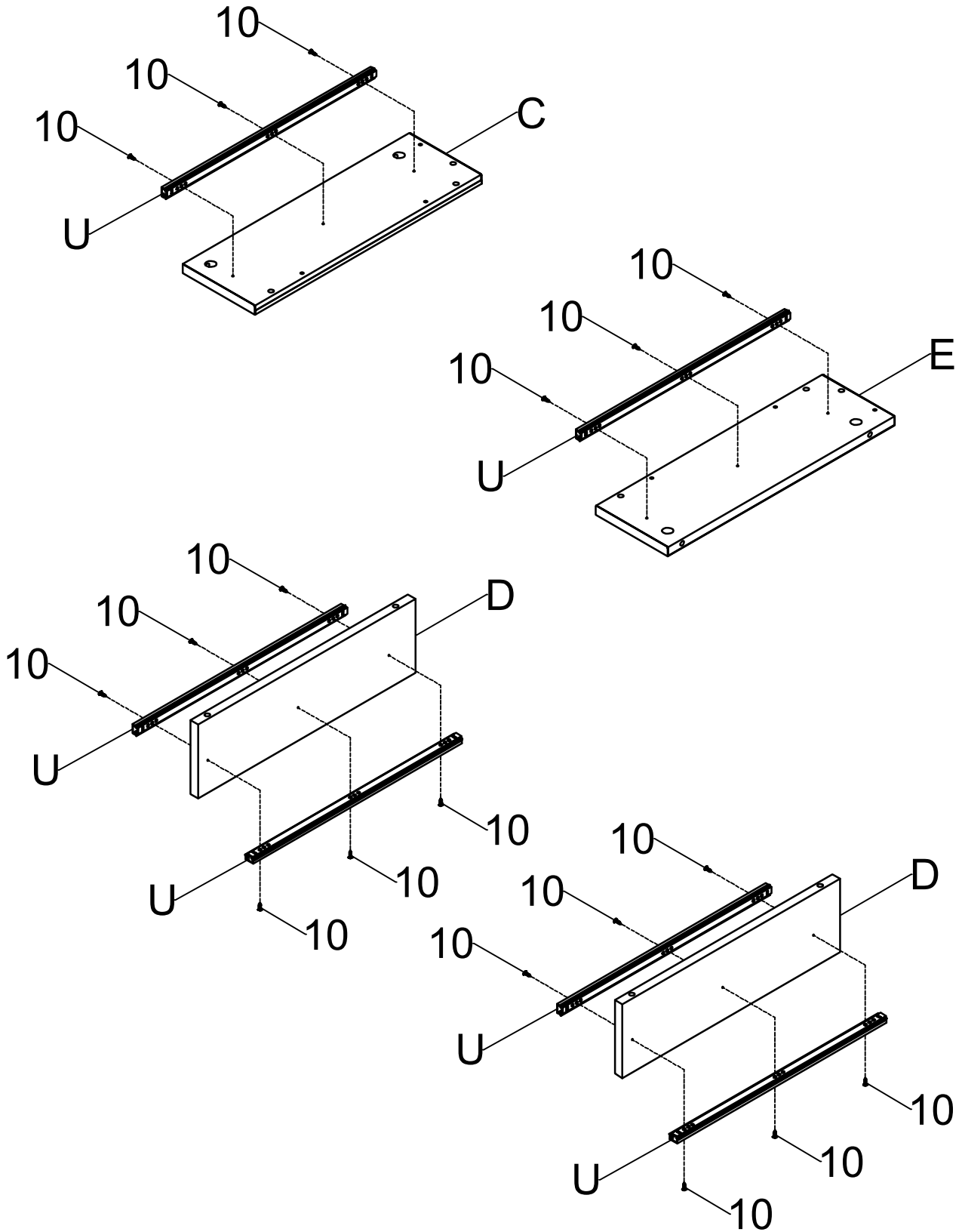

ASSEMBLY INSTRUCTIONS

STEP 2

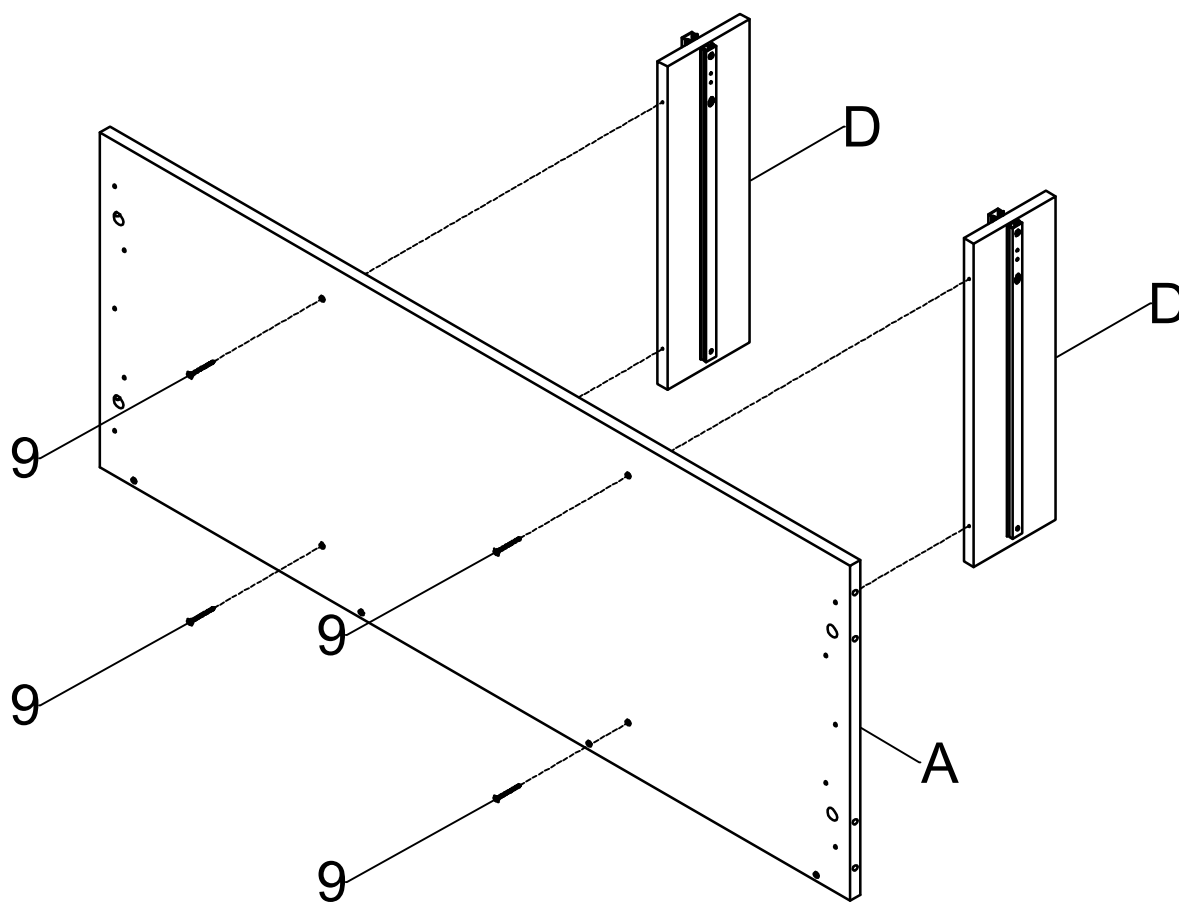

ASSEMBLY INSTRUCTIONS

STEP 3

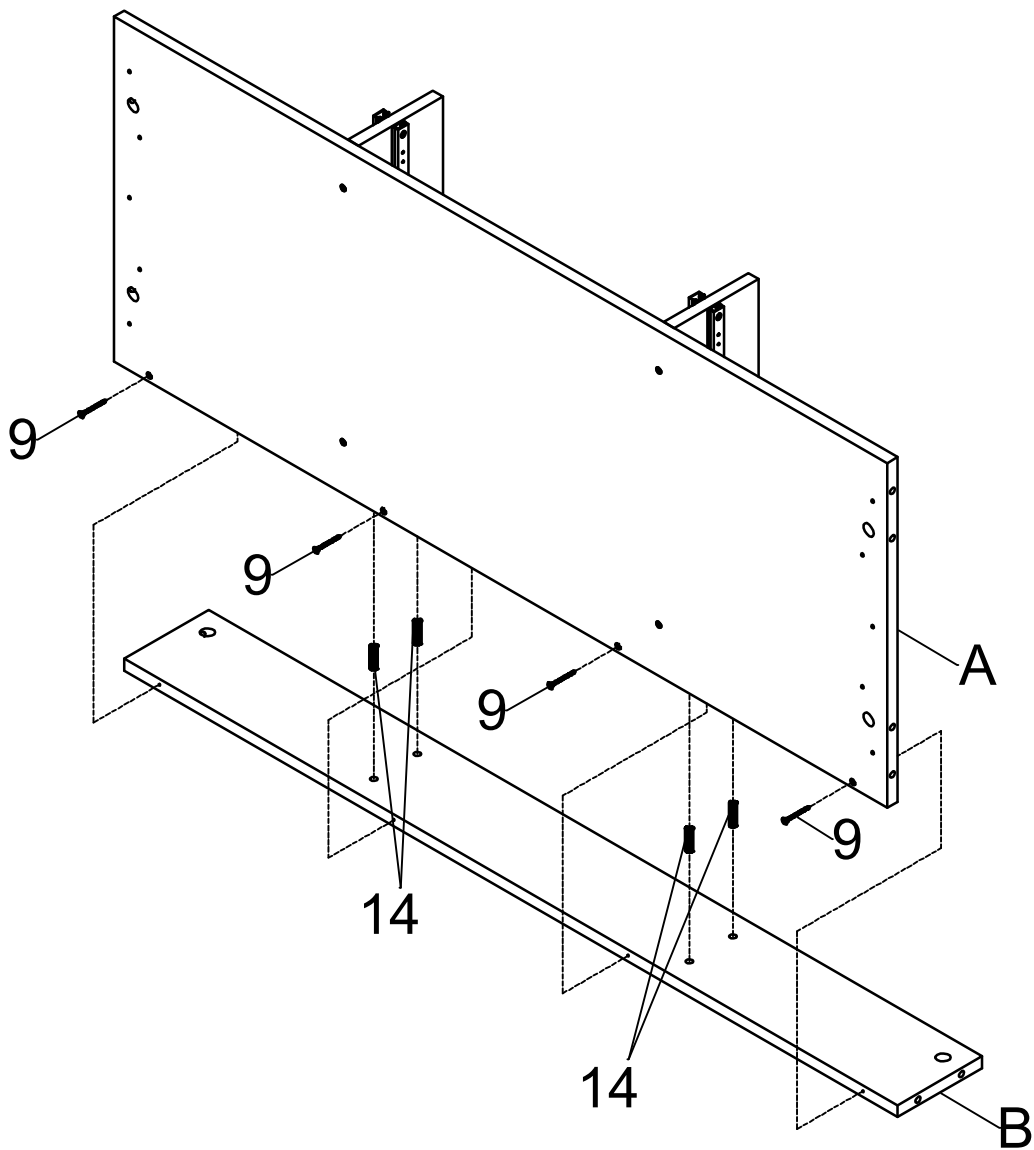
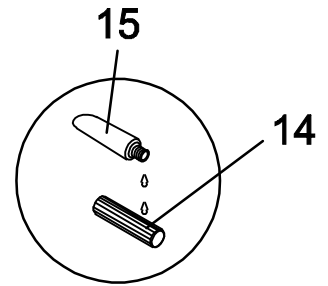

ASSEMBLY INSTRUCTIONS

STEP 4

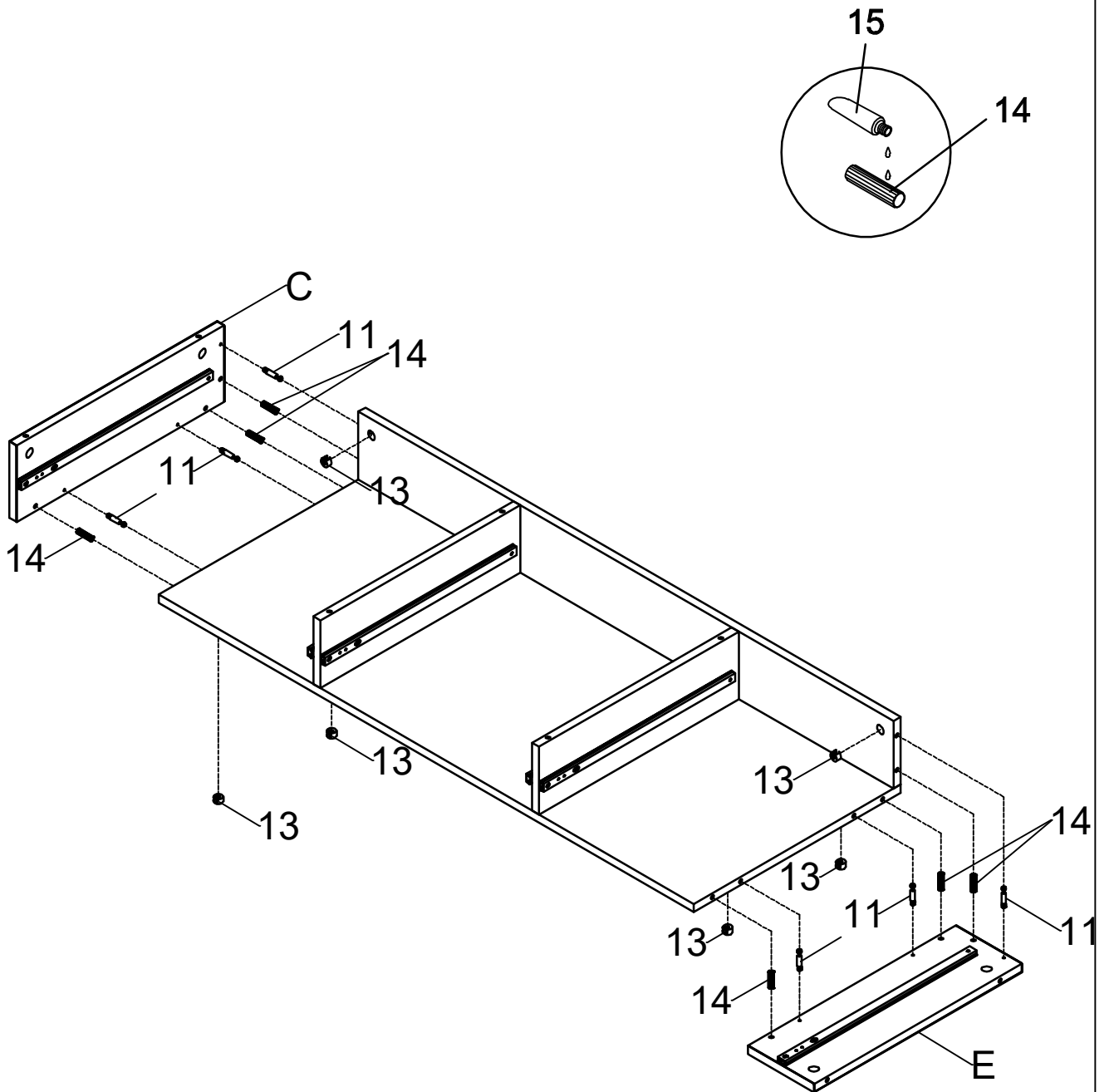

ASSEMBLY INSTRUCTIONS

STEP 5

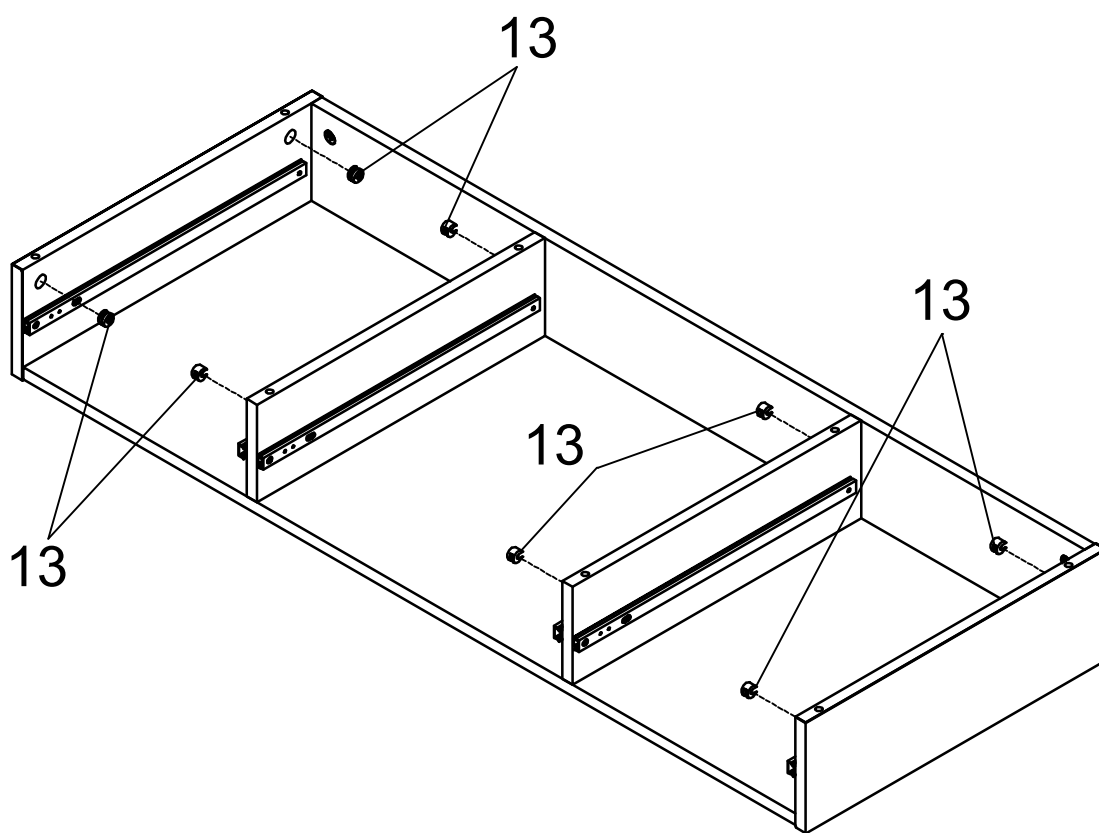

ASSEMBLY INSTRUCTIONS

STEP 6

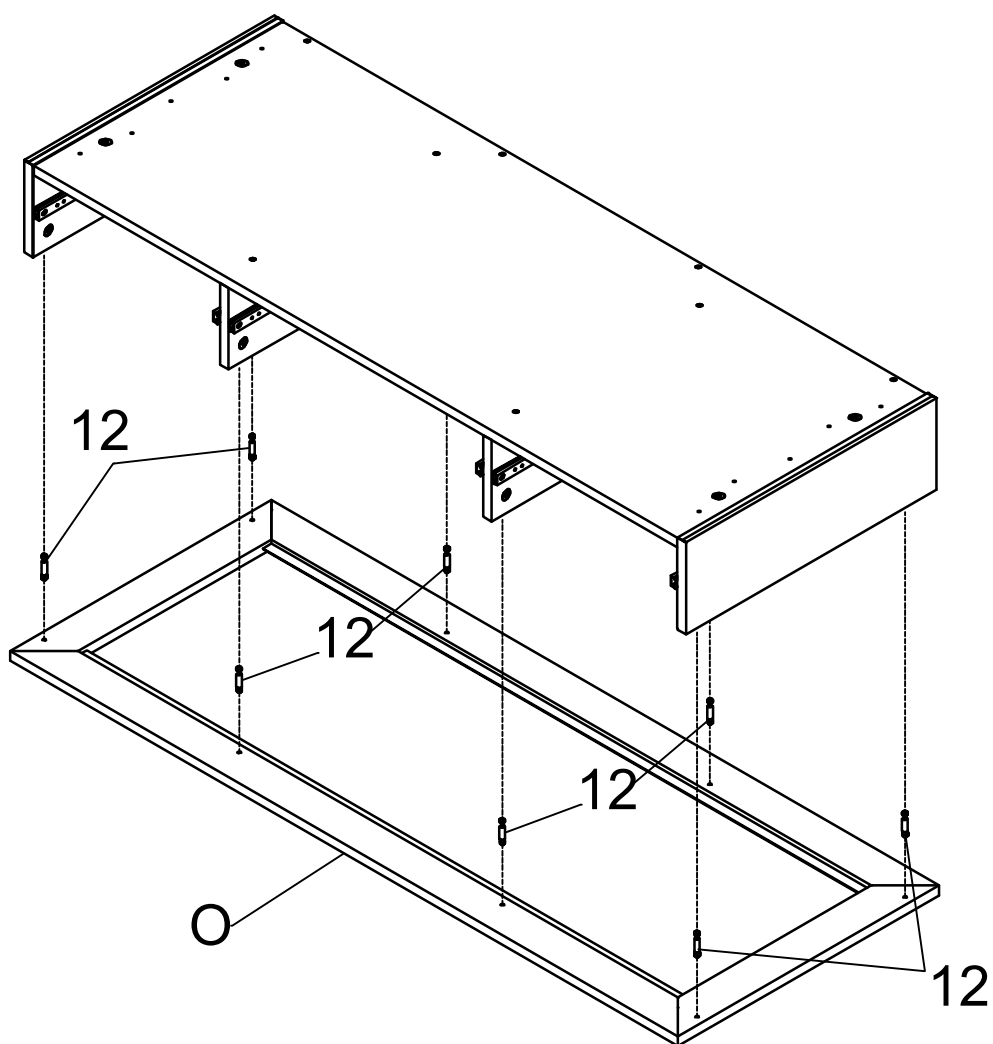

ASSEMBLY INSTRUCTIONS

STEP 7

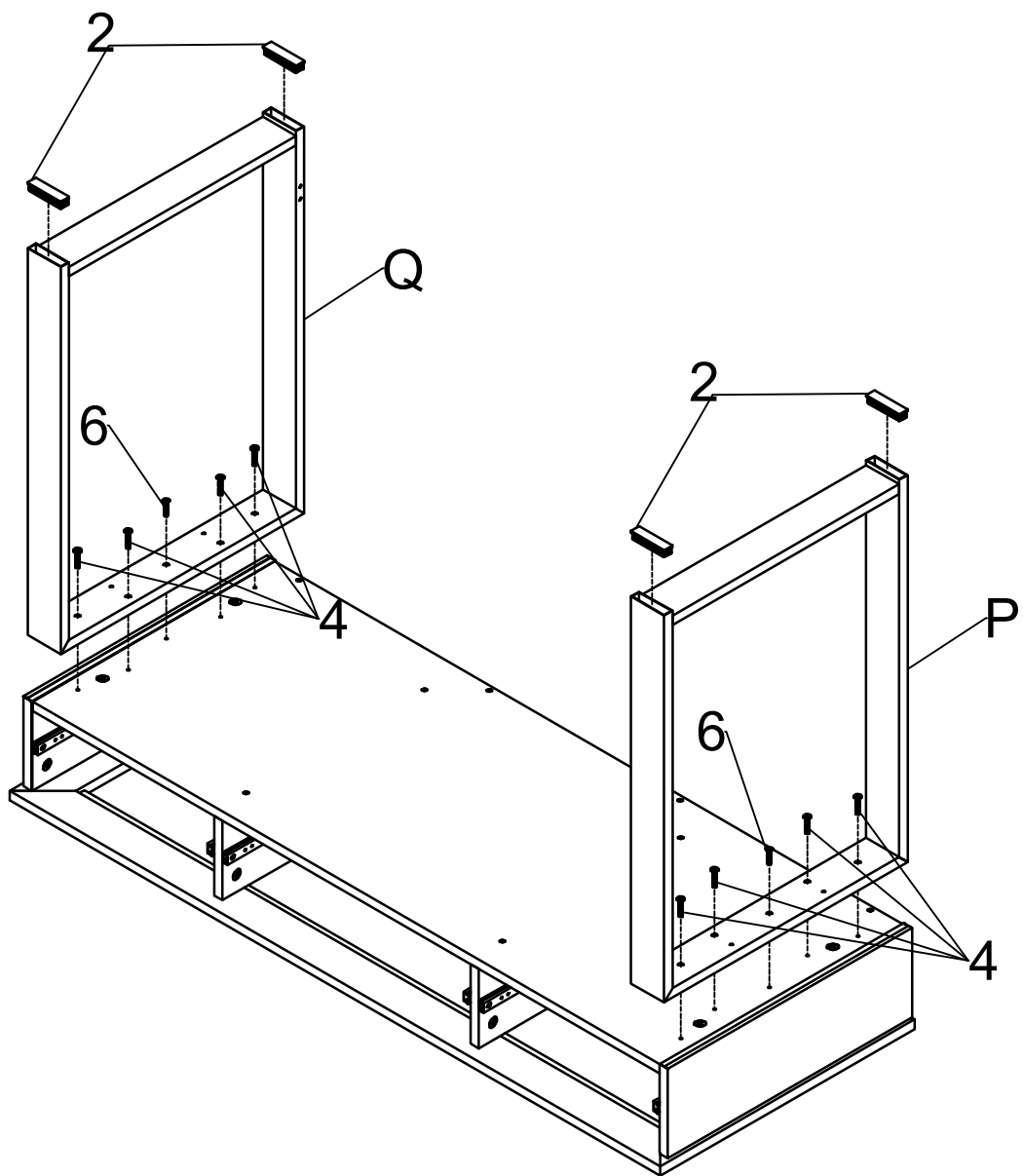

ASSEMBLY INSTRUCTIONS

STEP 8

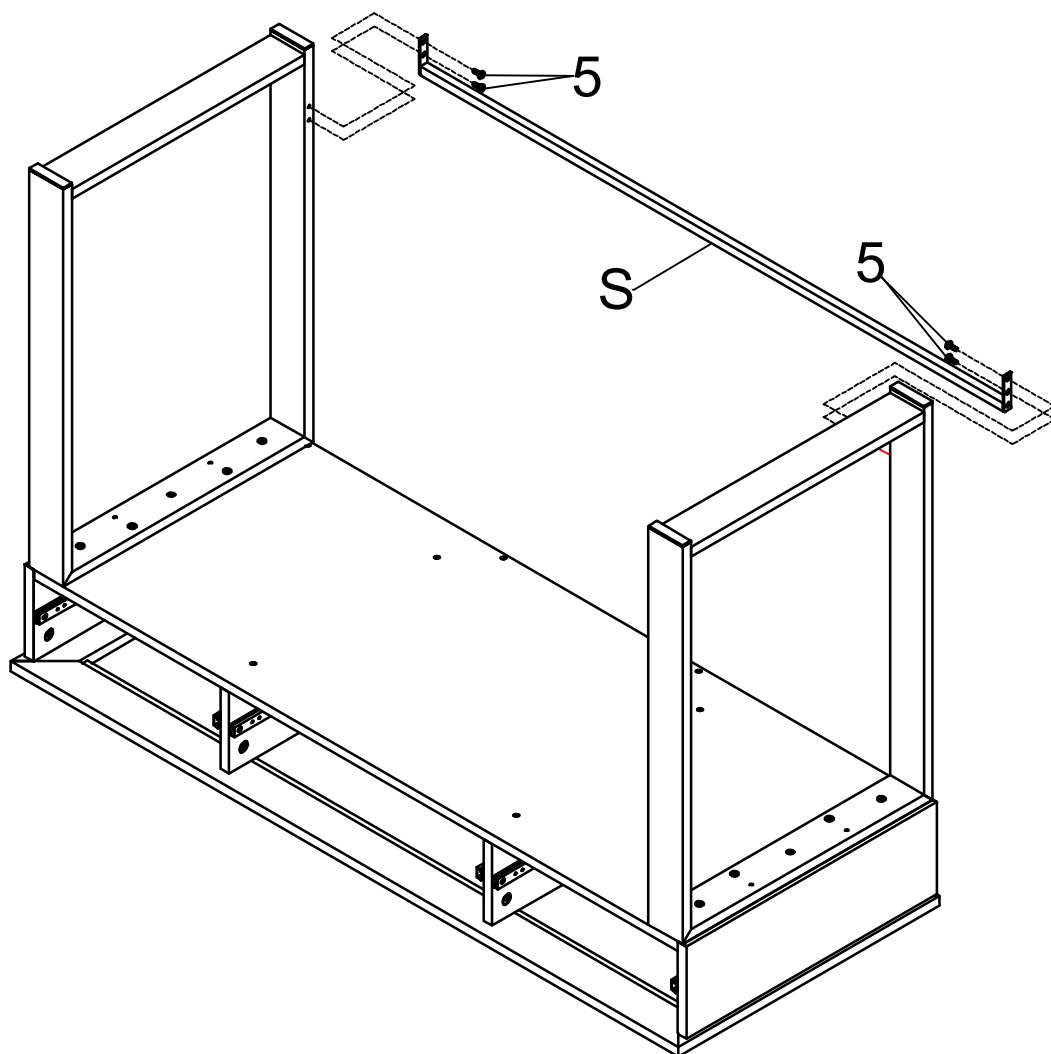

ASSEMBLY INSTRUCTIONS

STEP 9

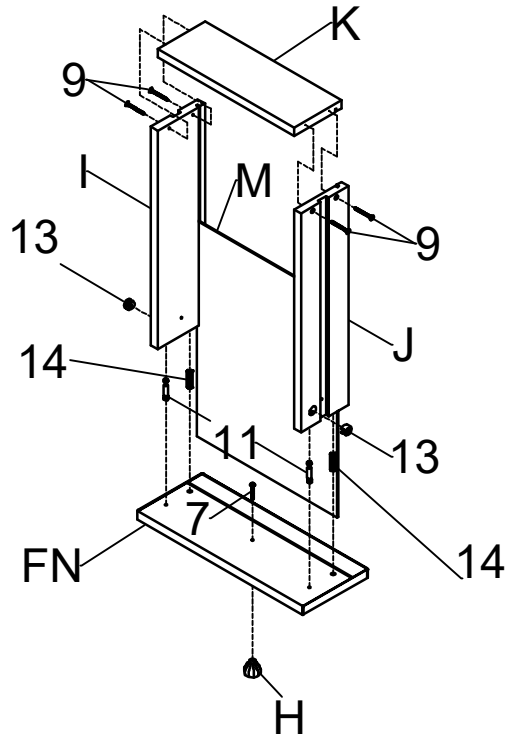
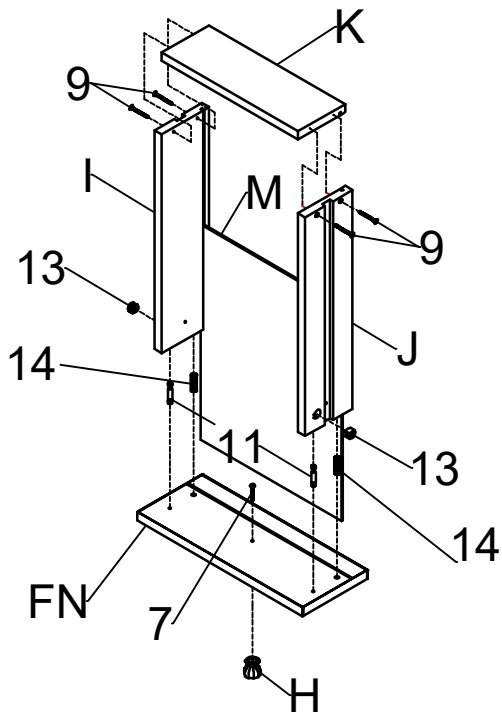
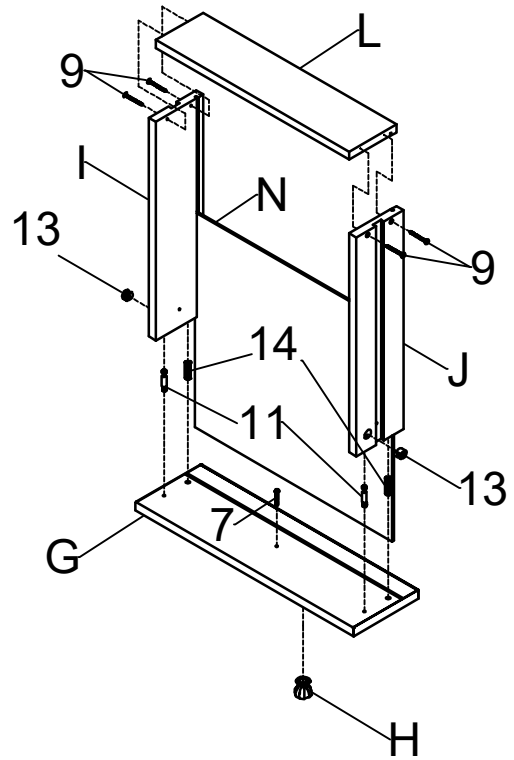
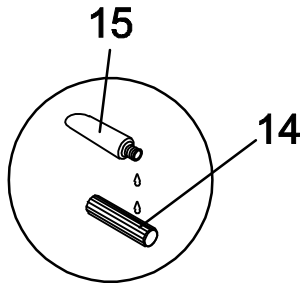

ASSEMBLY INSTRUCTIONS

STEP 10

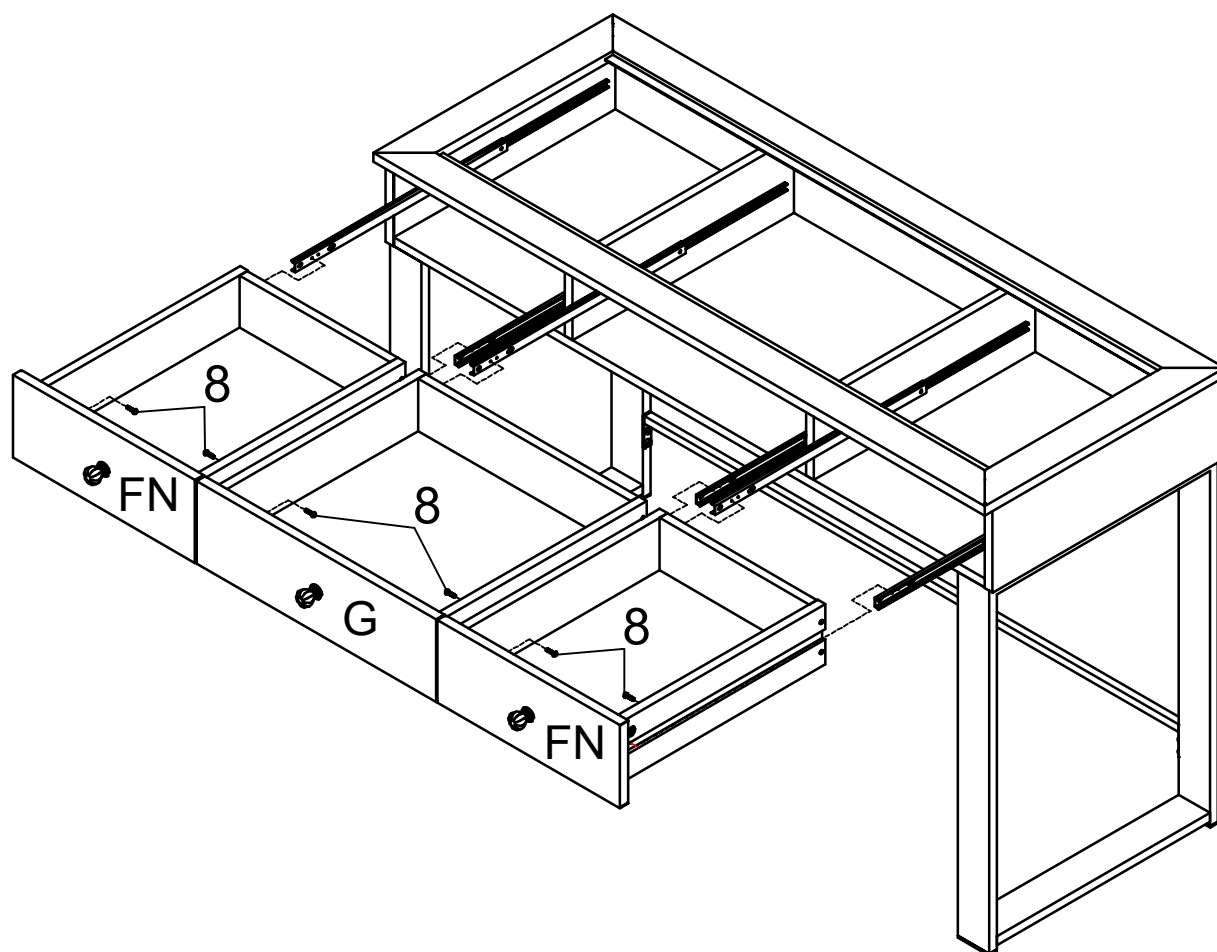

ASSEMBLY INSTRUCTIONS

STEP 11

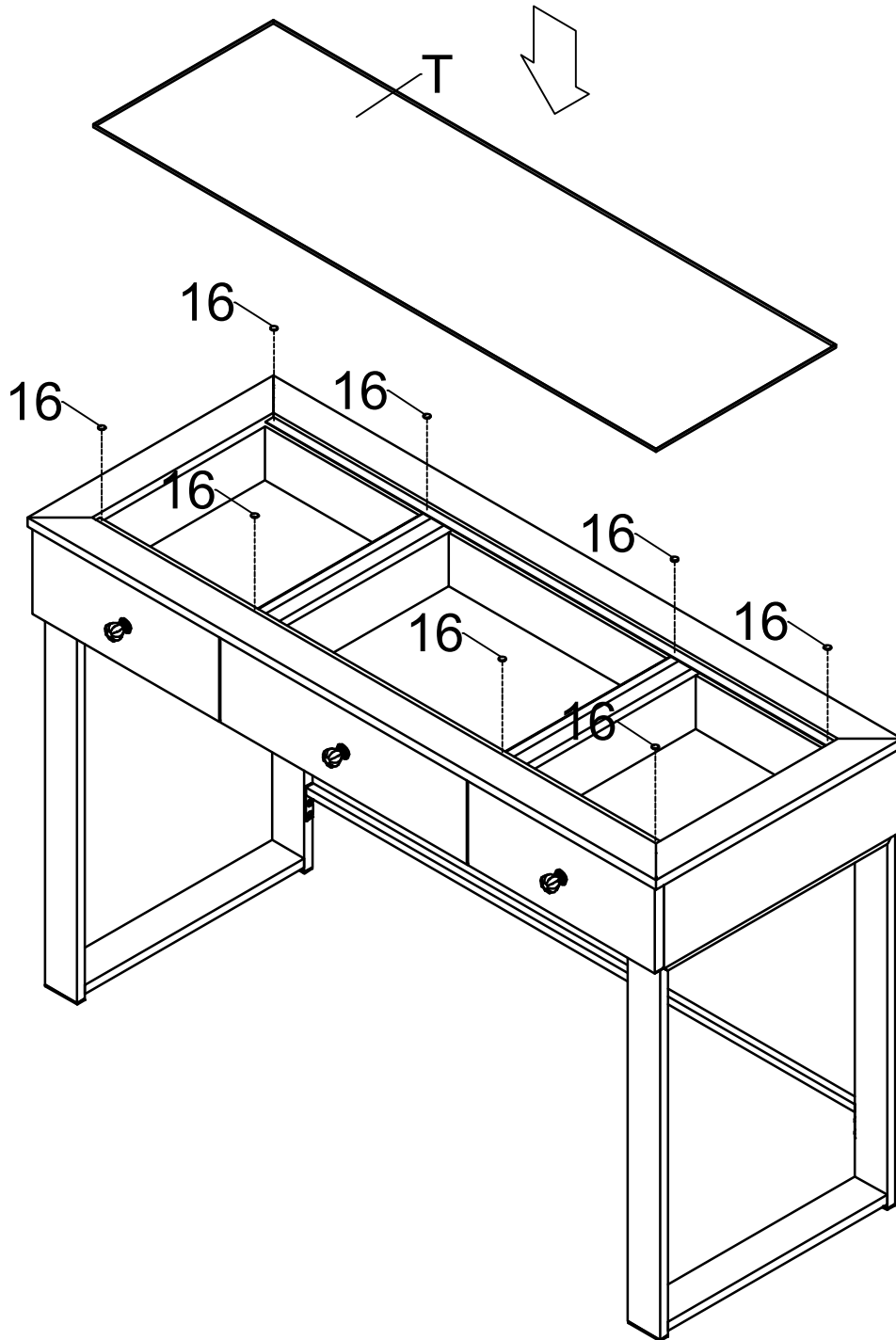

ASSEMBLY INSTRUCTIONS

STEP 12

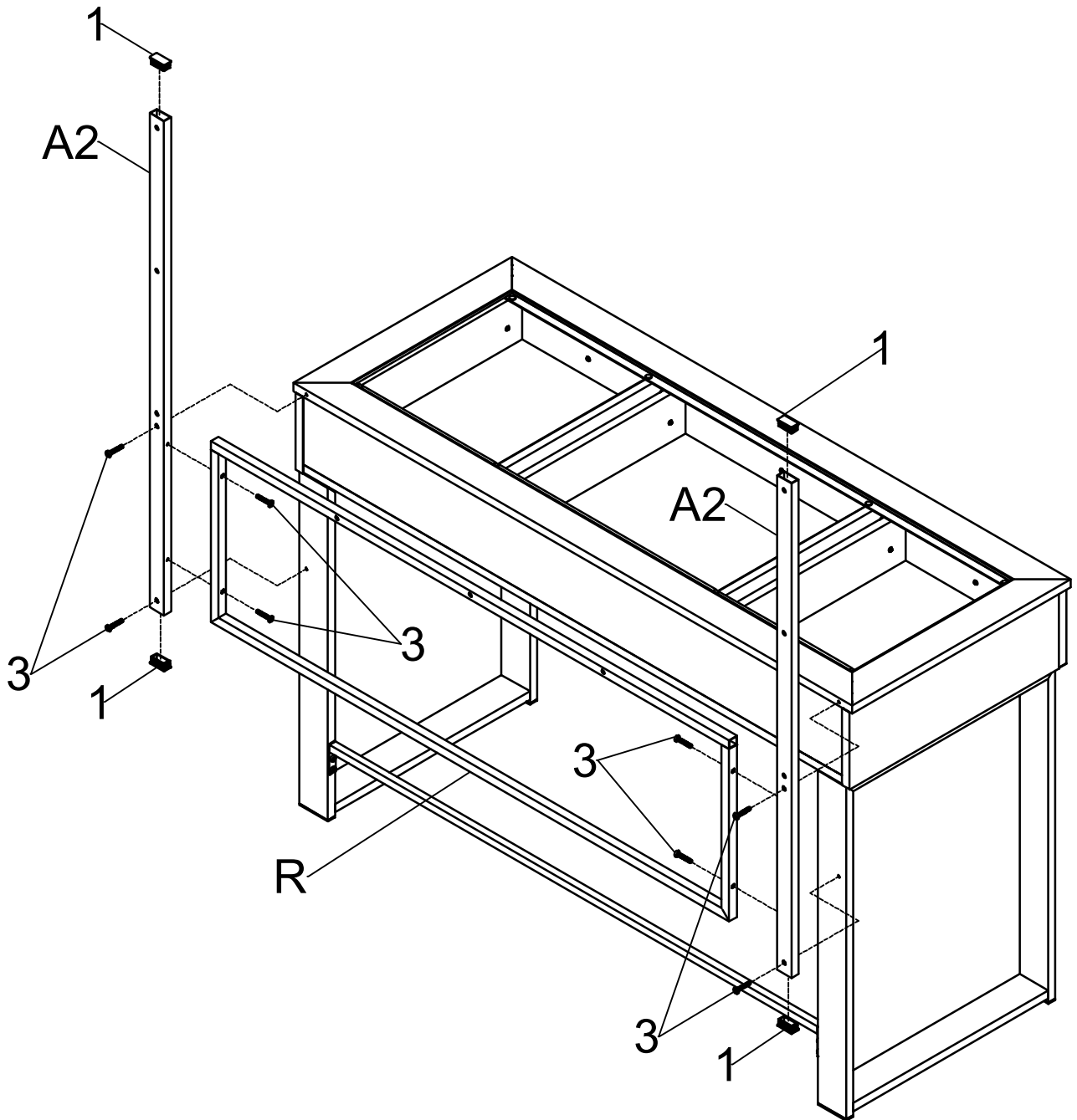

ASSEMBLY INSTRUCTIONS

STEP 13

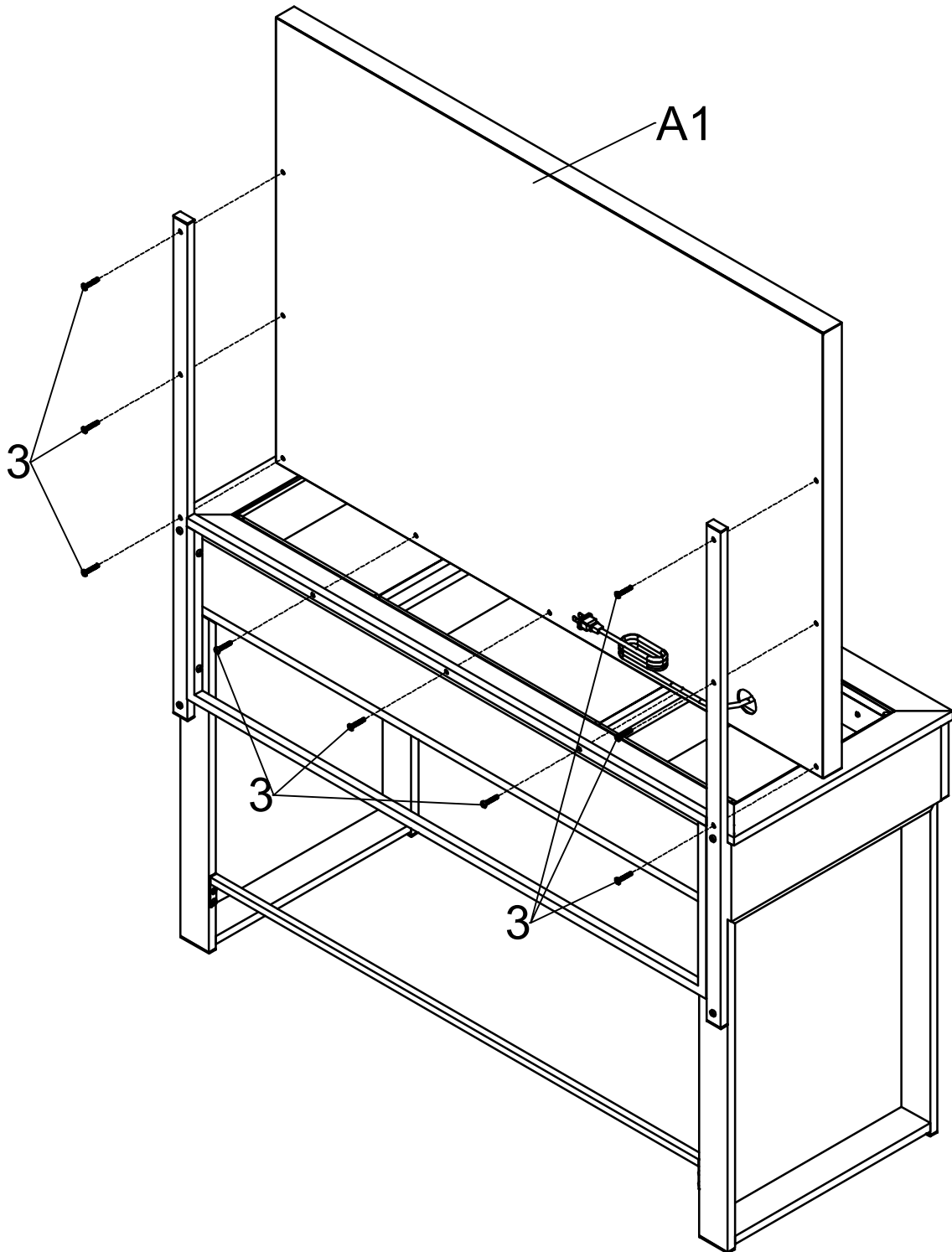

ASSEMBLY INSTRUCTIONS

STEP 14
COMPLETE

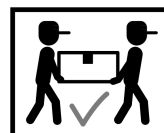
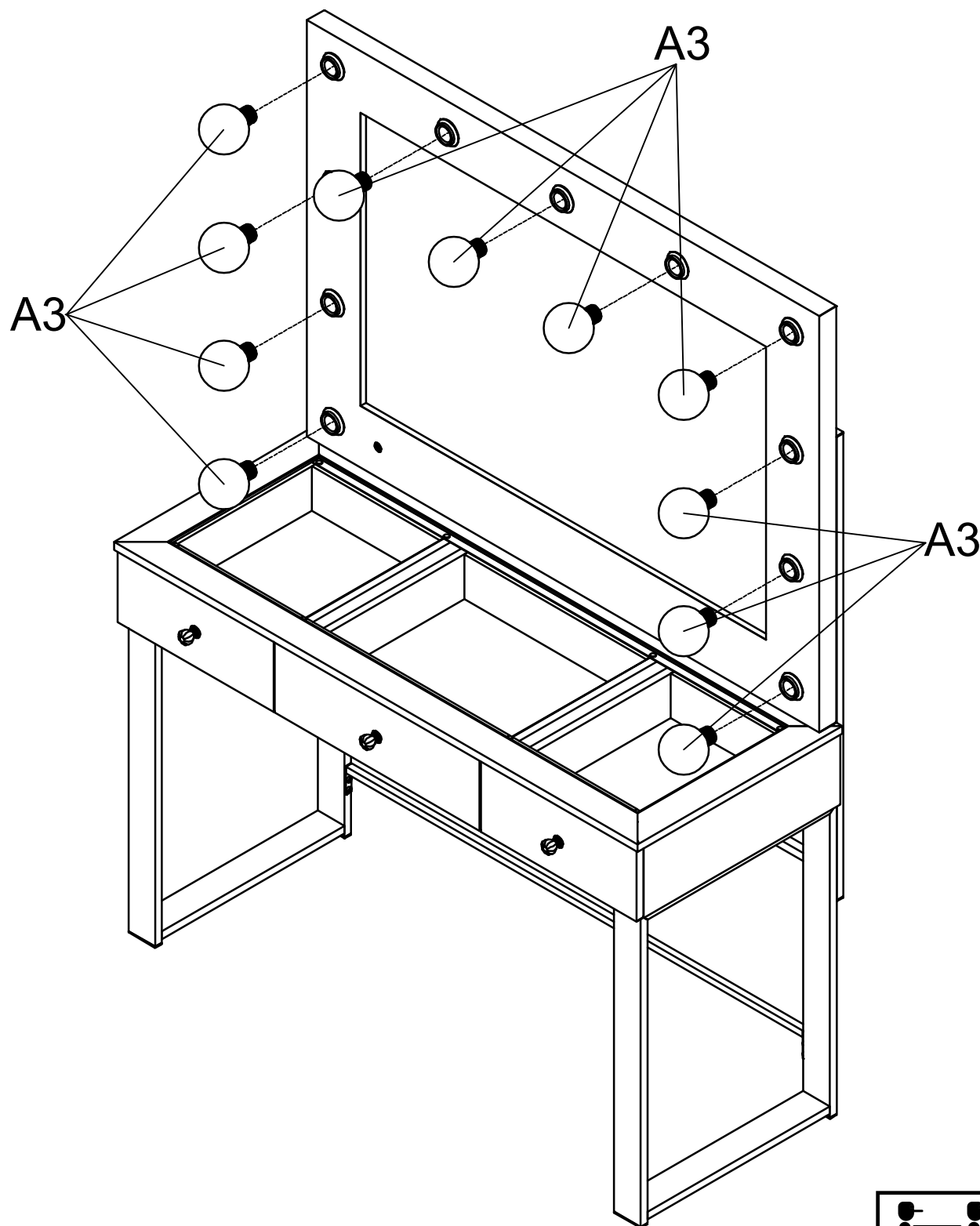

ASSEMBLY INSTRUCTIONS

Product Size : 1175 X 495 X 1575 H (MM)

Product Size : 46.25" X 19.5" X 62"

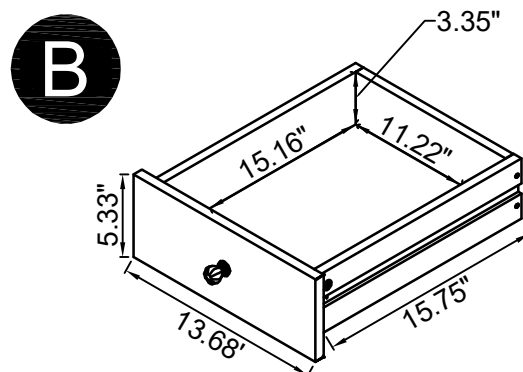
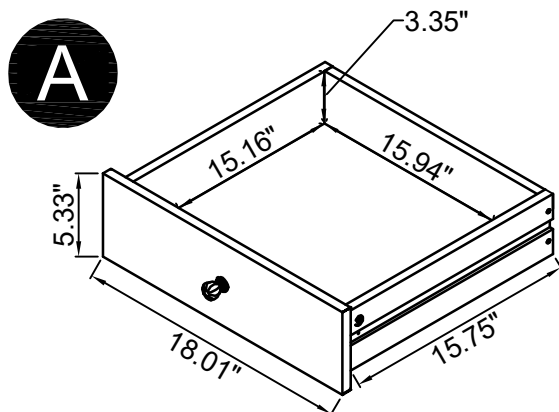
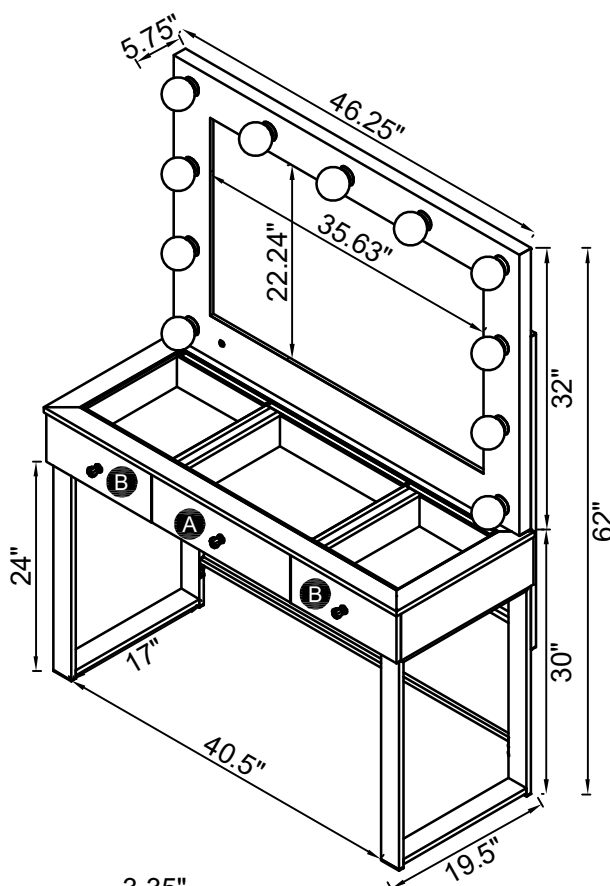

Note : Dimension tolerance $\pm 5\%$

ANTI-TIPPING INSTALLMENT INSTRUCTIONS

FURNITURE TIPPING RESTRAINT

WARNING

Injury may result from tipping furniture.
This restraint may protect against tipping furniture.
Do not allow children to climb on furniture.
This restraint is not a substitute for proper adult supervision.
Failure to detach this restraint before moving the furniture may result in injury and damage.

This tip restraint must be attached to a wall stud using long screw enclosed.

STEP 1

Attach a bracket securely to the back top rail of the furniture using short screw provided, through the smaller hole.

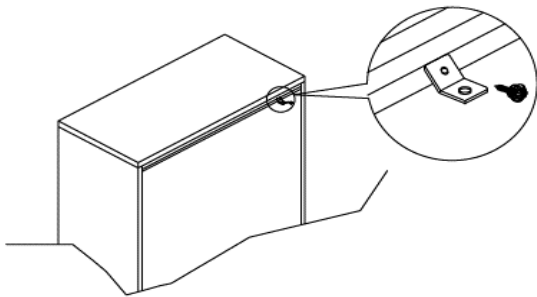

STEP 2

Locate the other bracket on the wall over a plastic wall stud and two inches below the mounting bracket secured to the back of the furniture. Attach the wall stud using the long screw provided, through the smaller hole.

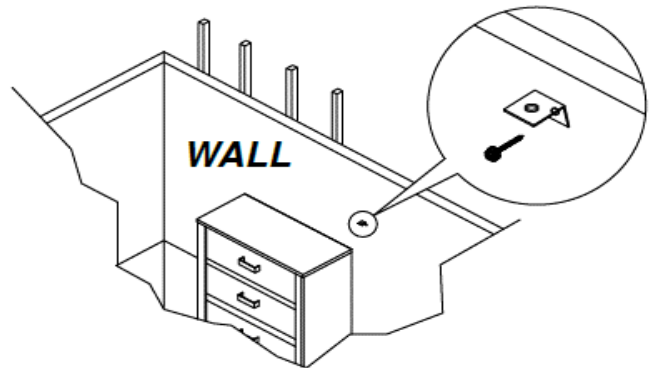

STEP 3

Place the furniture into position so both mounting brackets are vertically in line. Lace the end of the restraint strap through the larger hole in each mounting bracket. Bring both ends together and slide the flat end through the locking end and draw it through until all slack is removed. Confirm that the strap is securely laced and locked.

