

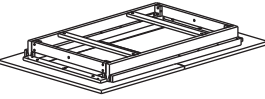





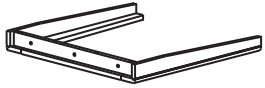
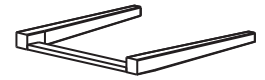

Assembly Instruction

TRIPLE LEAVES EXTENSION TABLE

NO	Parts List		Q'TY
A		Table Top	1 pce
B		Table Leaf	3 pcs
C		Leg 01	2 pcs
D		Leg 02	2 pcs

NO	Hardware List		Q'TY
1		M8x 40mm JCBC Bolt	8 pcs
2		M8x70mm JCBC Bolt	8 pcs
3		M8x18x1.2mm Lock Washer	16 pcs
4		(5/16") M8X13.5x1.8mm Flat Washer	16 pcs
5		M5 x 2.1/2" Allen Key	1 pce

STEP 1

Important Note

Need 2 adult to flip over the assembled table. Do not lean any weight on table leg during the flipping process.

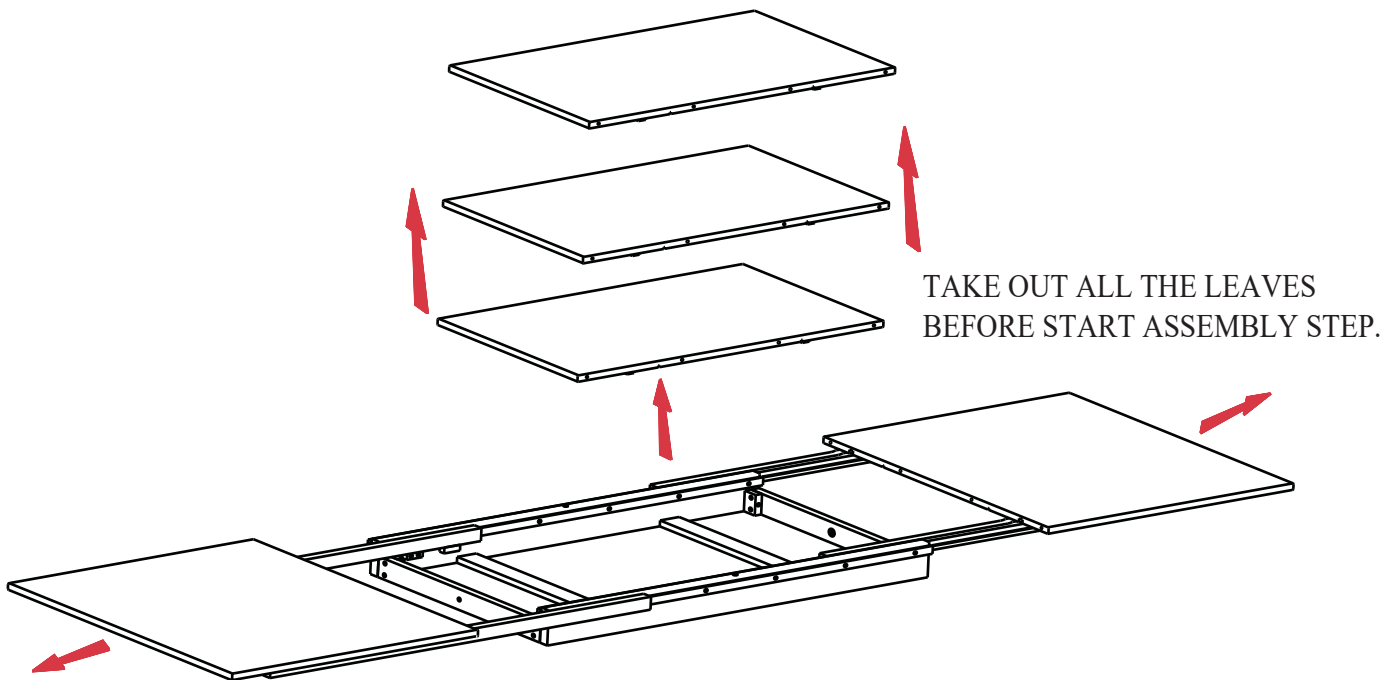

Assembly Instruction

TRIPLE LEAVES EXTENSION TABLE

STEP 2

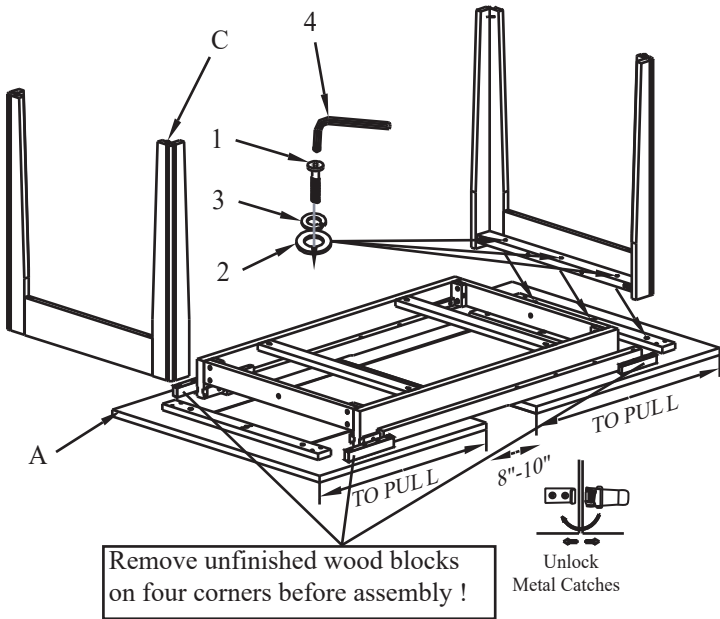

STEP 3

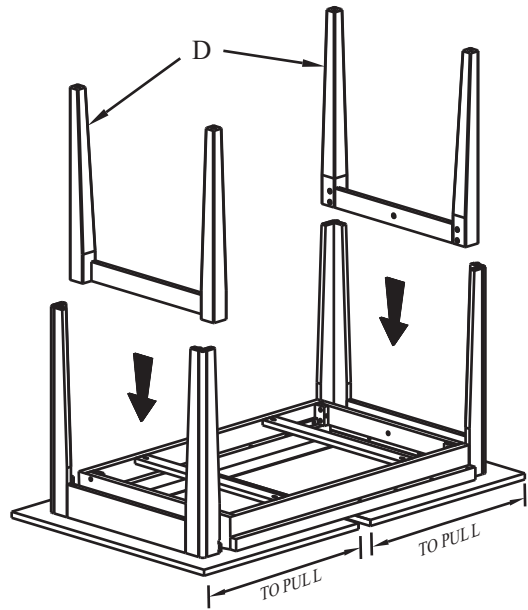

STEP 4

After installing the table legs, please set the table right side up.

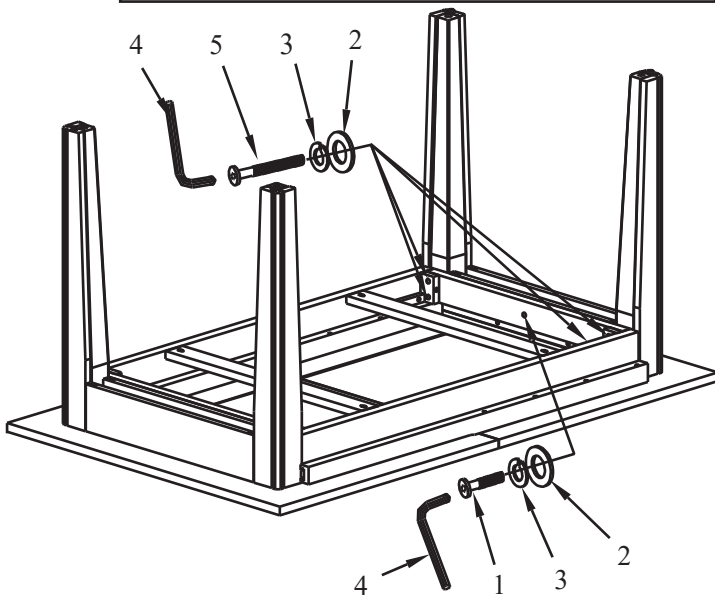

STEP 5

Please caution to lift table lightly and not drag the legs along the floor surface when pulling the two ends out in order to fit the table leaves in.

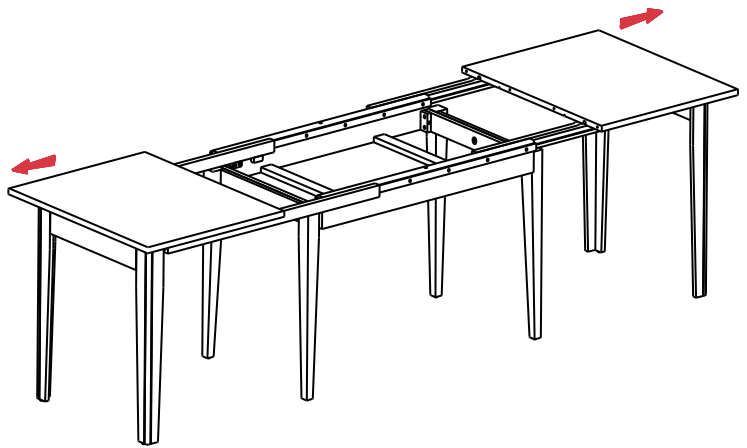

STEP 6A (Variation with one leaf in)

Please install leaf in center dowel first.

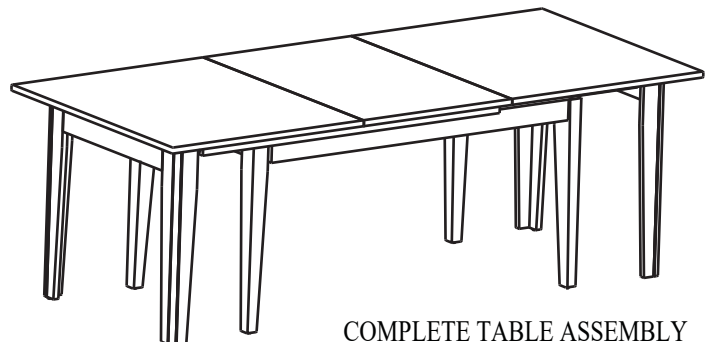
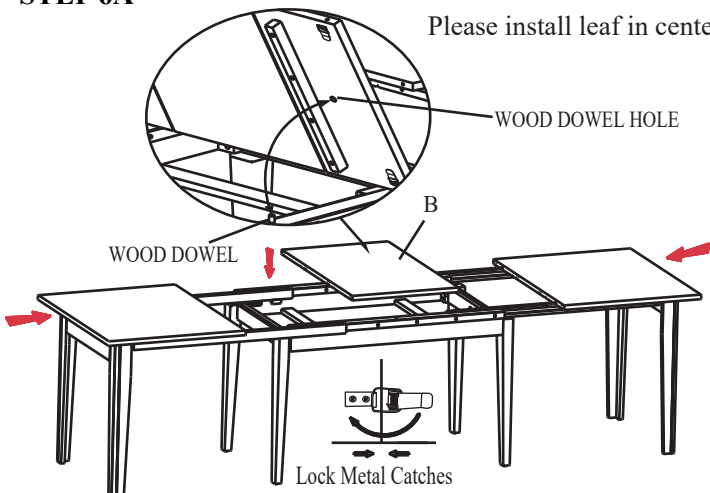

COMPLETE TABLE ASSEMBLY

Assembly Instruction

TRIPLE LEAVES EXTENSION TABLE

STEP 6B

(Variation with two leaves in)

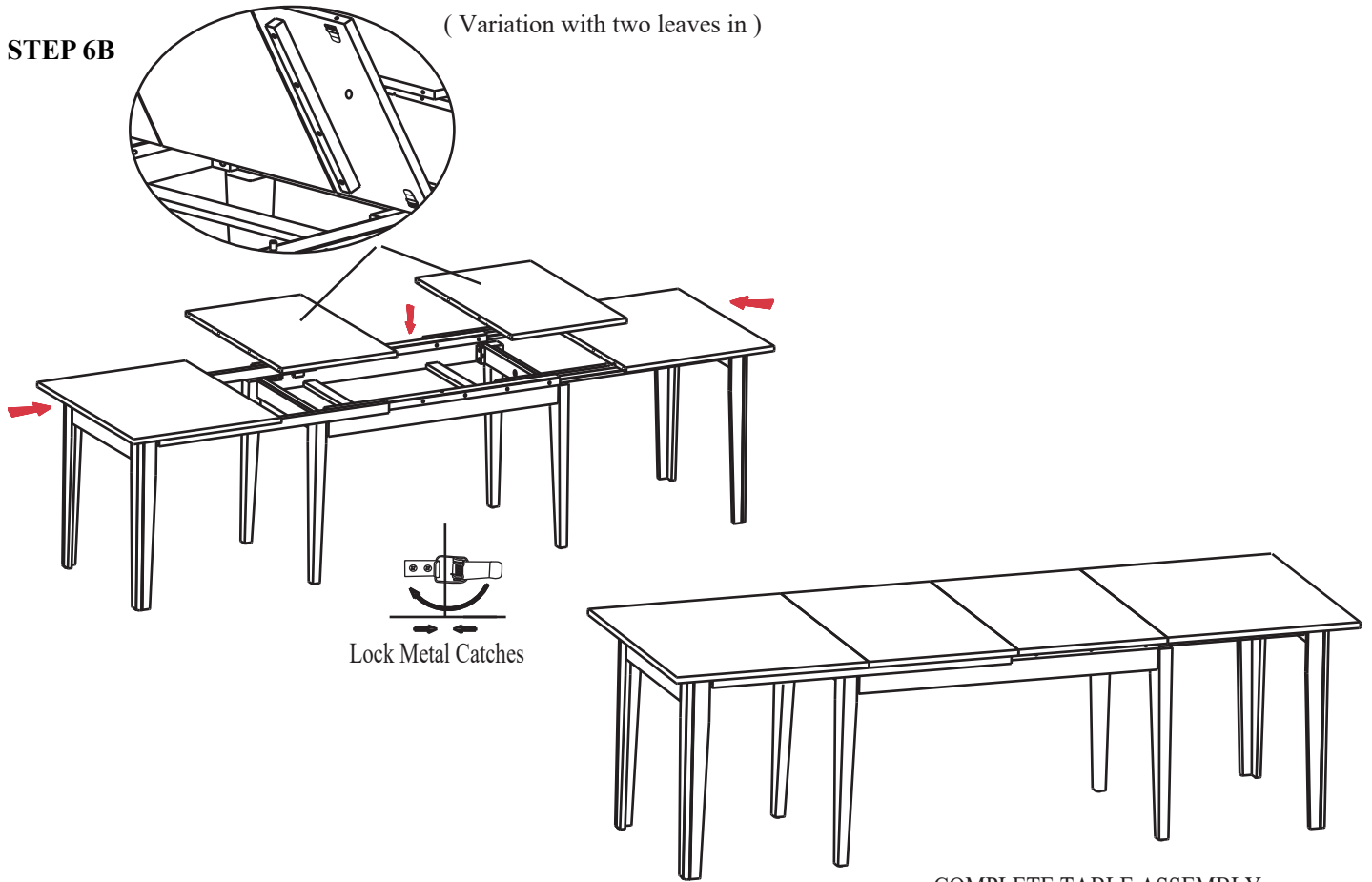

COMPLETE TABLE ASSEMBLY

STEP 6C (Variation with three leaves in)

Please install leaf in center dowel first.

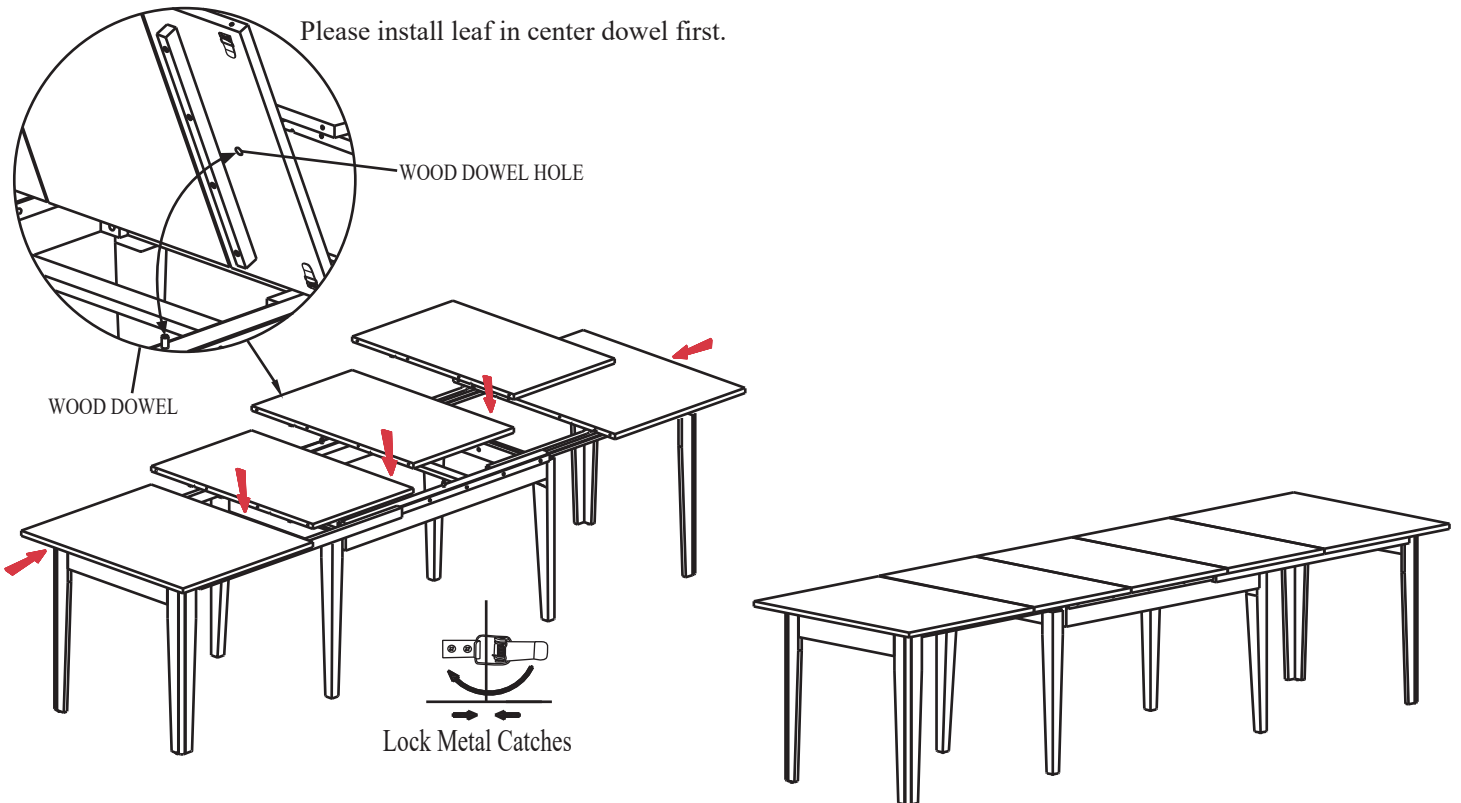

COMPLETE TABLE ASSEMBLY