

PET TREADMILL OWNER'S MANUAL

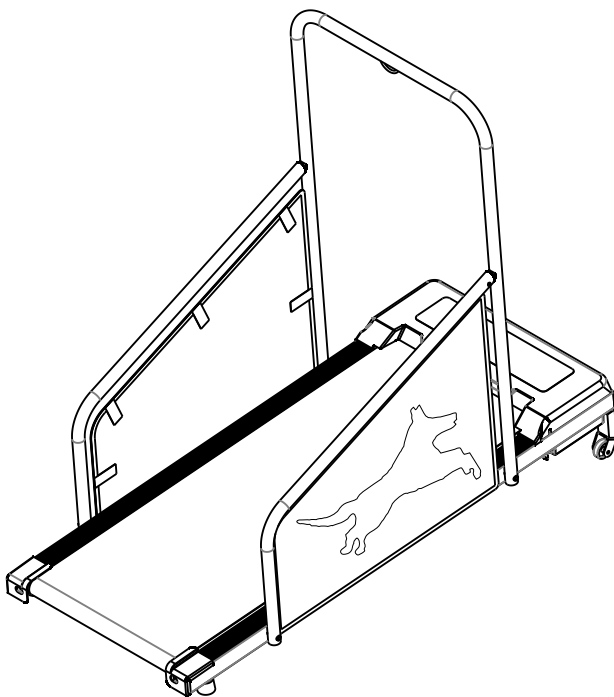

USER'S MANUAL

Thank you very much for purchasing our product.
Please read this manual carefully before use it and keep the manual at proper place.

SAFETY INSTRUCTIONS

CAUTION: User weight on this product should not exceed 220lbs.

IMPORTANT:

Read all instructions carefully before using this product. Retain this owner's manual for future reference. Instructions for assembly, including correct fitting of guards and other device, and warnings about the likely injuries to young children if exercise equipments are operated in their without properly fitted guards.

WARNING:

If any discomfort should result from your use of this product, stop exercising and consult your doctor. Proper usage of this product is essential. Please read your manual carefully before exercising.

Please keep all children and pets away from the equipment during use and when equipment is unattended. The appliance is not intended for use by young children or infirm persons without supervision. Young children should be supervised to ensure that they do not play with the appliance.

Always wear appropriate clothing, including athletic shoes when exercising.

Do not wear loose clothing that could become caught during exercise. Make sure that all bolts and nuts are tightened when equipment is in use. Periodic maintenance is required on all exercise equipment in order to keep it in good condition.

Observe the following prior to use of the treadmill:

DANGER: To reduce the risk of electric shock, please observe the following:

Always unplug the treadmill from the electrical outlet immediately after using and before cleaning, assembling or servicing.

NOTE: Failure to follow these instructions may lead to personal injury and cause damage to the treadmill.

- Never leave the treadmill unattended when plugged in. Disconnect by turning off the master has been dropped or damaged or if it has been exposed to water.
- Do not attempt any maintenance or adjustments other than those described in this manual power switch, and unplugging from outlet.
- Never operate this treadmill if it has a damaged cord or plug, is not working properly, if it. Should any problems arise, discontinue use and consult the qualified technician.
- Do not use outdoors.
- Do not operate where aerosol(spray can) products are being used or where oxygen is being administered.
- Do not pull the treadmill by its power cord or use the cord as a handle.
- Close supervision is necessary if this treadmill is used by, or near children, persons with disabilities, or pets.
- Keep dry, do not operates in a wet or moist condition. Save these instructions.
- Do not operate under a blanket. Excessive heating can occur and cause fire, electrical shock, or injury to persons.
- Keep electrical cord away from heated surfaces.
- Never insert any object into any opening.
- Only one pet at a time should use the machine.
- Use the machine only for its intended use as described in this manual. Do not use attachment not recommended by the manufacturer.
- Do not place any sharp object around the machine.
- Never operate this machine if it is not functioning properly.
- This machine should not be used for medical purposes.
- On your equipment yourself other than the assembly maintenance described in this manual.This equipment is for home use only.
- If the supply cord is damaged, it must be replaced by the manufacturer, or similarly qualified persons in order to avoid a hazard.
- Injuries to health may result from incorrect or excessive training.
- Keep the treadmill with sides at least 2ft from any walls, and always allow a clear space measuring 10ft wide by 20ft length for this equipment on a stable horizontal surface. Be sure that the area around the treadmill remains clear during use and has adequate clearance.

WARNING: Connect the treadmill to properly grounded outlet only.

● This product must be grounded. If it should malfunction or break down, grounding provides a path of least resistance for electric current reducing the risk of electric shock. This treadmill is equipped with a cord having equipment grounding connector and a grounding plug. The plug must be plugged into an appropriate outlet that is properly installed and grounded in accordance with all local codes and ordinances.

DANGER: Improper connection of the treadmill grounding connector can result in the risk of electric shock. Check with a qualified electrician, if you are in doubt as to whether the product is properly grounded. Do not modify the plug provided with the treadmill. If it will not fit your outlet, have a properly grounded outlet installed by a qualified electrician.

● Keep hands clear of all moving parts. Never place hands, feet under the treadmill.

● Do not use the treadmill on a carpet.

● Before each use, check that the running belt is aligned and centered on the treadmill deck and all visible fasteners on the treadmill are sufficiently tightened and secure.

PRODUCT PARTS:

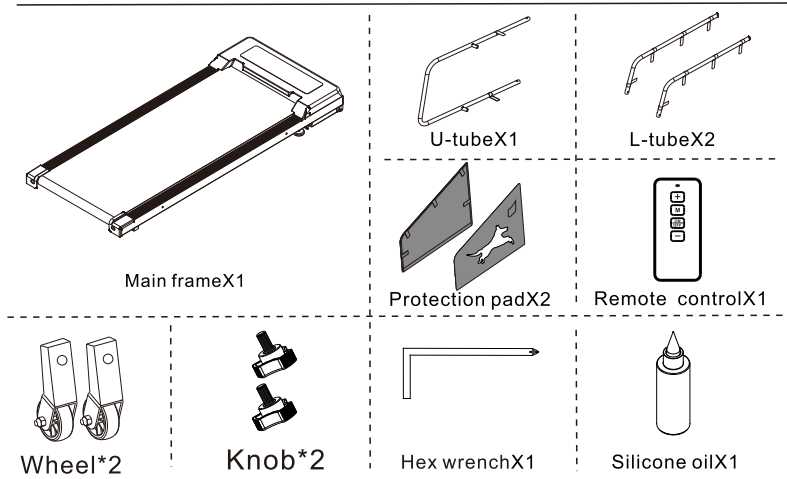

MAIN PARTS OF NAME:

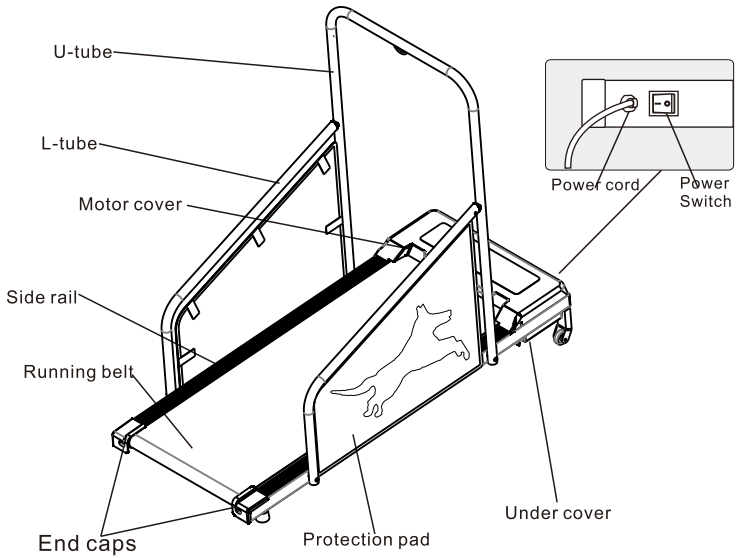

ASSEMBLY INSTRUCTIONS

Warning: Do not connect the Treadmill to a power source before completing assembly.

Open the carton, remove the main frame and the components and place it on the floor in an open area.

1

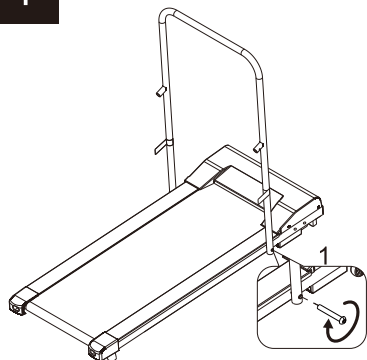

Assemble U-tube using the pre-installed screws as Fig 1

2

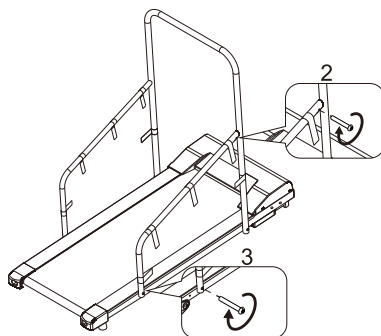

Assemble L-tube using the pre-installed screws as Fig 2 and Fig 3

3

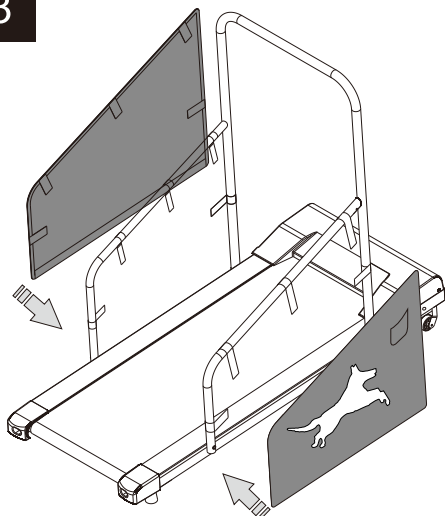

Adjust the velco fastener on the tube to proper place, then stick Protection pads as shown in the picture.

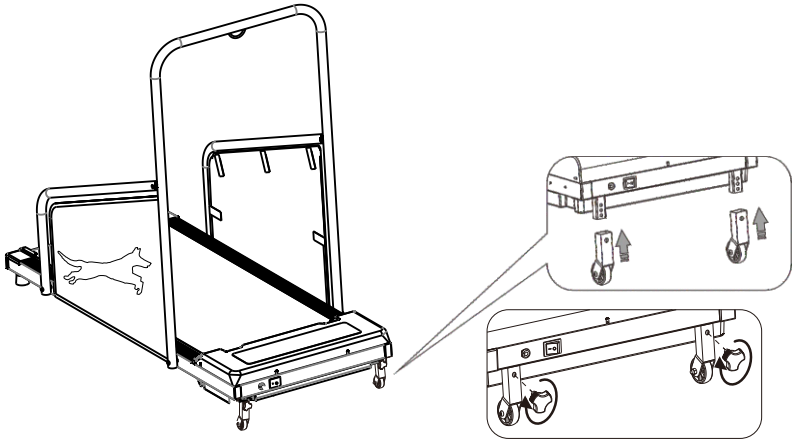

Assemble Wheels using the pre-installed knob as shown in the picture.

DISPALY WINDOW AND KEY

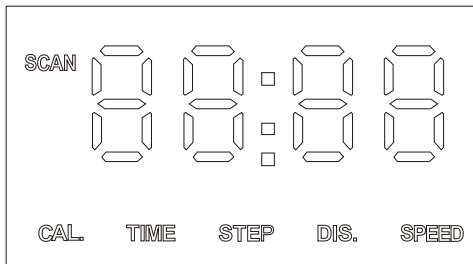

1.LED display screen:SCAN, CAL,TIME,STEP,DIS.,SPEED.

2. When the display window shows “E07”, place the Safety key on the computer for activate operations.

CONTROL OPERATION

- 1.Plug the power,then place safety key on the computer and turn on the power switch which is located at the front of the treadmill,The screen on the motor cover will display "0.0".
- 2.After installing the battery, press the "^{ON}/_{OFF}" on the control near the treadmill to start the treadmill,after 5 second countdown,the treadmill will start at the speed of 0. 6MP/H.
- 3.You may press the speed"+"or speed-" key to increase or decrease the running speed during exercise. Each increment or reduction will be of 0.1MP/H.

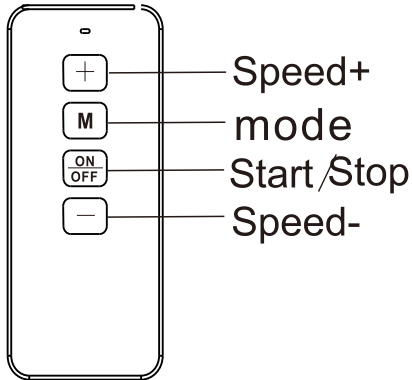

4.Mode key(M)

In the standby state, press M to periodically select CAL., TIME, STEP, DIS., and SPEED. (When selecting various modes, you can use the speed plus or minus key to set the relevant backward counting value, and press the ON/OFF key to start the treadmill after setting.) In the running state, press this key to select the required display page. When SCAN is on, it is in the cyclic state, and the cycles are SPEED, TIME, DIS., CAL., and STEP in sequence.

NOTE1:the treadmill will make a "BI" sound under any v alid press

DAILY MAINTENANCE

WARNING:

Turn off and unplug the treadmill before proceeding with any maintenance or visual inspections. Failure to do so may result in serious injury.

AT THE END OF EVERY EXERCISE SESSION ALWAYS

1. Use the Power Switch to turn the treadmill off.
2. Always position and store the Power Cord where it is clear from all pathways.
3. Unplug the Power Cord from the electrical outlet. This is especially important if you are not going to use your treadmill for extended periods.
4. Wipe all treadmill surface with a dry cloth or towel especially perspiration on the handlebars, console, running belt or other treadmill components.
5. Check and tighten screws at fixing point
6. Do not hang clothes or other objects on the machine

STORAGE

● Store your treadmill in a clean and dry environment. Ensure the Power Switch is off and is unplugged from the electrical outlet.

MOVING

● The treadmill has been designed and equipped with wheels (11) for easy mobility. Before moving, ensure the Power Switch is in the 'OFF' position and the power cord is unplugged from the electrical outlet. Tilt the base frame of the treadmill and then roll the treadmill to the desired position.

LUBRICATION YOUR TREADMILL

The treadmills have already been spread with "Silicone Oil" in advance before leaving the manufacturing plant. Silicone oil is without volatility and has gradually permeated through the running belt. There will be no need to re-spread the oil in normal circumstances.

To maintain the running belt, we have included a small bottle of "Silicone Oil". "Silicone Oil" may be re-spread once the resistance has been increased and the running belt starts rubbing against the running deck. To hold open the center of the running deck. Allow the silicone oil to 'set' for one minute before using the treadmill.

NOTE: Only use "Silicone Oil" lubricants for this equipment. In addition, do not add any other oil ingredient; otherwise the treadmill will be damaged. Do not over-lubricate the walking board. Excess lubricant should be wiped off with a clean towel.

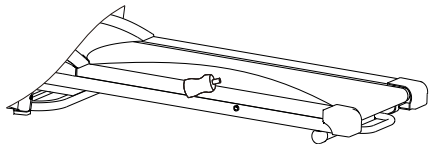

RUNNING BELT ADJUSTMENT

- a) Adjust speed to 3km/h
- b) If the running belt deflects to the right, adjust the bolt on the left one turn clockwise by Hex wrench until the running belt is centered (see pic 1)
- c) If the running belt deflects to the left, adjust the bolt on the right one turn clockwise by Hex wrench until the running belt is centered (see pic 2)
- d) If the running belt is not deflected, but is slipping, adjust both left and right bolts one half turn clockwise to tighten, or one half turn anti-clockwise to loosen if the belt is too tight. (See pic 3 and 4)
- e) After adjustment, check the running belt, and adjust further if required.

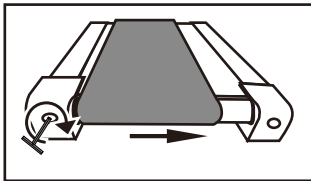

Pic 1. The adjustment for deflection to the right

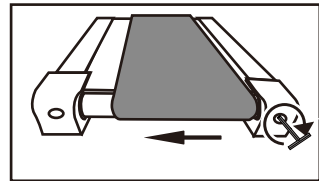

Pic 2. The adjustment for deflection to the left

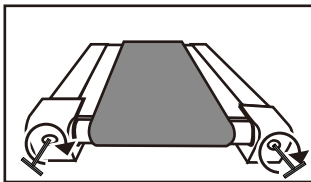

Pic 3. Tightening the running belt

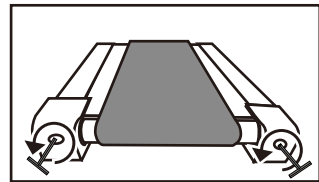

Pic 4. Loosening the running belt

OVERVIEW DRAWING

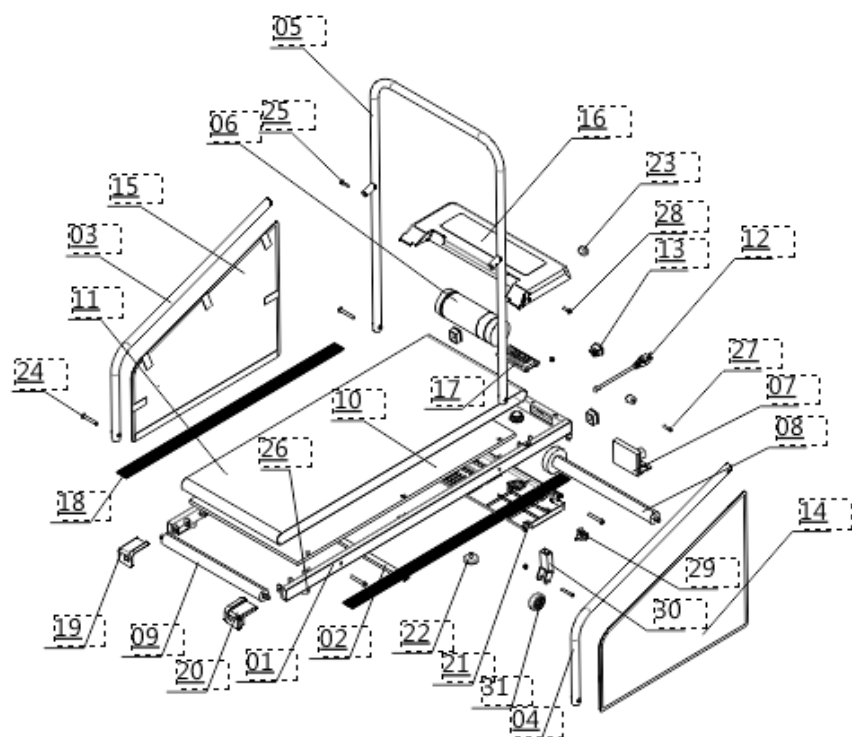

PARTS LIST

N0.	Name	PCS
1	Main frame	1
2	Frame Support Tubes	1
3	Left side connecting rod	1
4	right-hand connecting rod	1
5	Gantry	1
6	Motors	1
7	Electronic Controls	1
8	Front Roller	1
9	Rear Roller	1
10	Running boards	1
11	Running belt	1
12	Power cord	1
13	Power switch	1
14	Right Oxford cloth	1
15	Left Oxford cloth	1
16	Motor top cover	1
17	Display boards	1
18	Sidebars	2
19	Left rear corner guard	1
20	Right rear corner guard	1
21	Motor lower cover	1
22	Round footrests	2

N0.	Name	PCS
23	Roller	2
24	Socket head hexagon	4
25	Phillips pan head screws	2
26	Round footrests	2
27	screws	2
28	screws	2
29	Triangular knob	2
30	Adjustment bracket	2
31	Roller	2