

As this item contains many parts, please read the installation instruction carefully before installation and complete the installation with the cooperation of your partner. Please use tools properly and carefully. If you have any questions about the product and installation, please contact us.

Our professional after-sales team will serve you online all day.

Before You Start

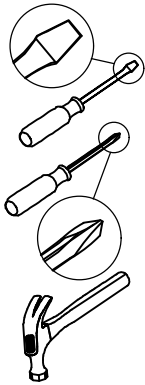

- ✓ Read through each step carefully and follow the proper order
- ✓ Separate and count all your parts and hardware
- ✓ Give yourself enough room for the assembly process
- ✓ Have the following tools: Flat Head Screwdriver, #2 Phillips Head Screwdriver and Hammer
- ✓ Caution: If using a power drill or power screwdriver for screwing, please be aware of to slow down and stop when screw is tight. Failure to do so may result in stripping the screw.

Helpful Hints

PEOPLE NEEDED FOR ASSEMBLY: 1-2

- Open your item in the area you plan to keep it to avoid excessive heavy lifting.
- Identify, sort and count the parts before attempting assembly.
- Compression dowels are lightly tapped in with a hammer.
- Slides are labeled with an **R** (right) and **L** (left) for proper placement.
- Make sure to always face the point on the top of the Cam Lock towards the outer edge.
- Use all the nails provided for the back panel and spread them out equally.
- Back panel must be used to make sure your unit is sturdy.
- Do NOT use harsh chemicals or abrasive cleaners on this item.
- Never push, pull, or drag your furniture.

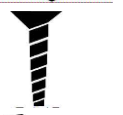

Board Identification

Not actual size

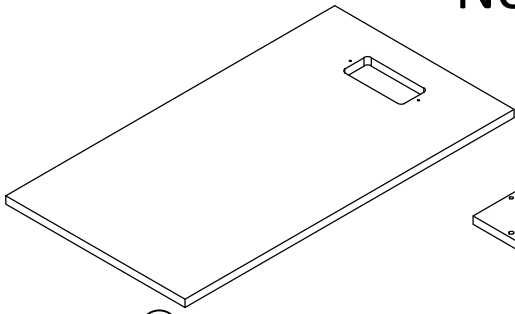

(A)
TOP
Qty:1

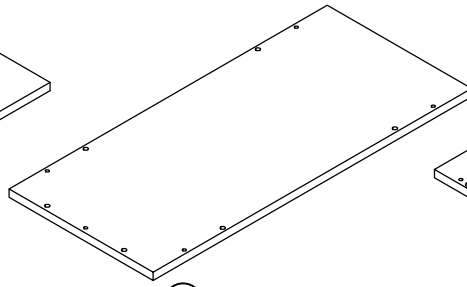

(B)
FIXED SHELF
Qty:1

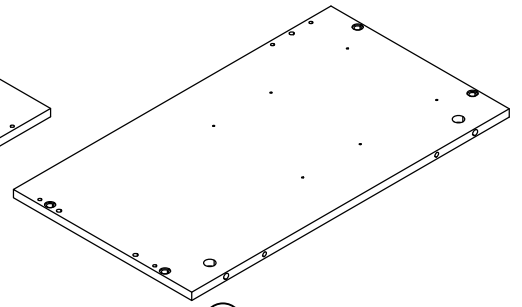

(C)
LEFT SIDE PANEL
Qty:1

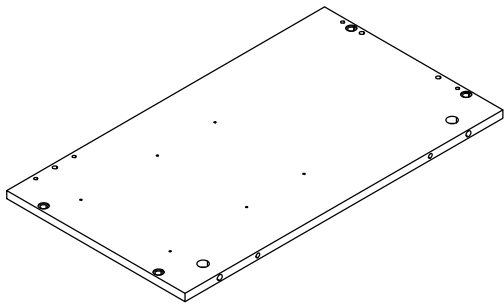

(D)
RIGHT SIDE PANEL
Qty:1

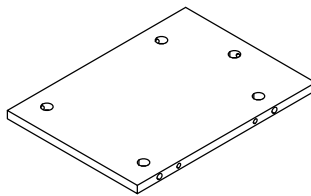

(E)
BACK PANEL
Qty:1

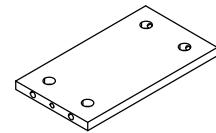

(F)
BOTTOM
Qty:1

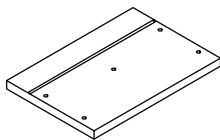

(G)
DRAWER FRONT
Qty:2

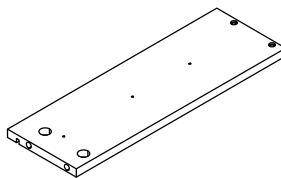

(H)
DRAWER LEFT PANEL
Qty:2

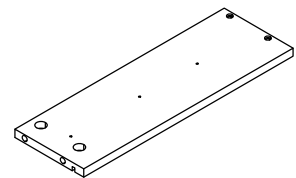

(I)
DRAWER RIGHT PANEL
Qty:2

Board Identification

Not actual size

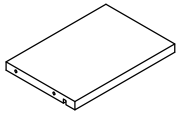

ⓐ

DRAWER BACK PANEL
Qty:2

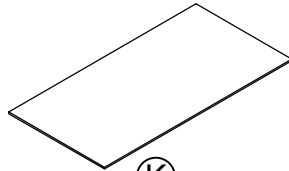

ⓑ

DRAWER BOTTOM
Qty:2

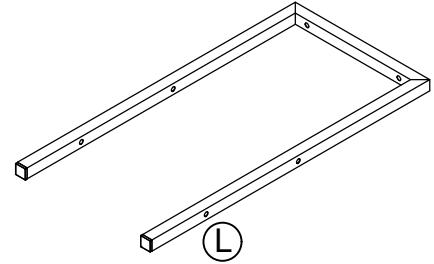

ⓒ

METAL SIDE FRAME
Qty:2

Board Identification

Not actual size

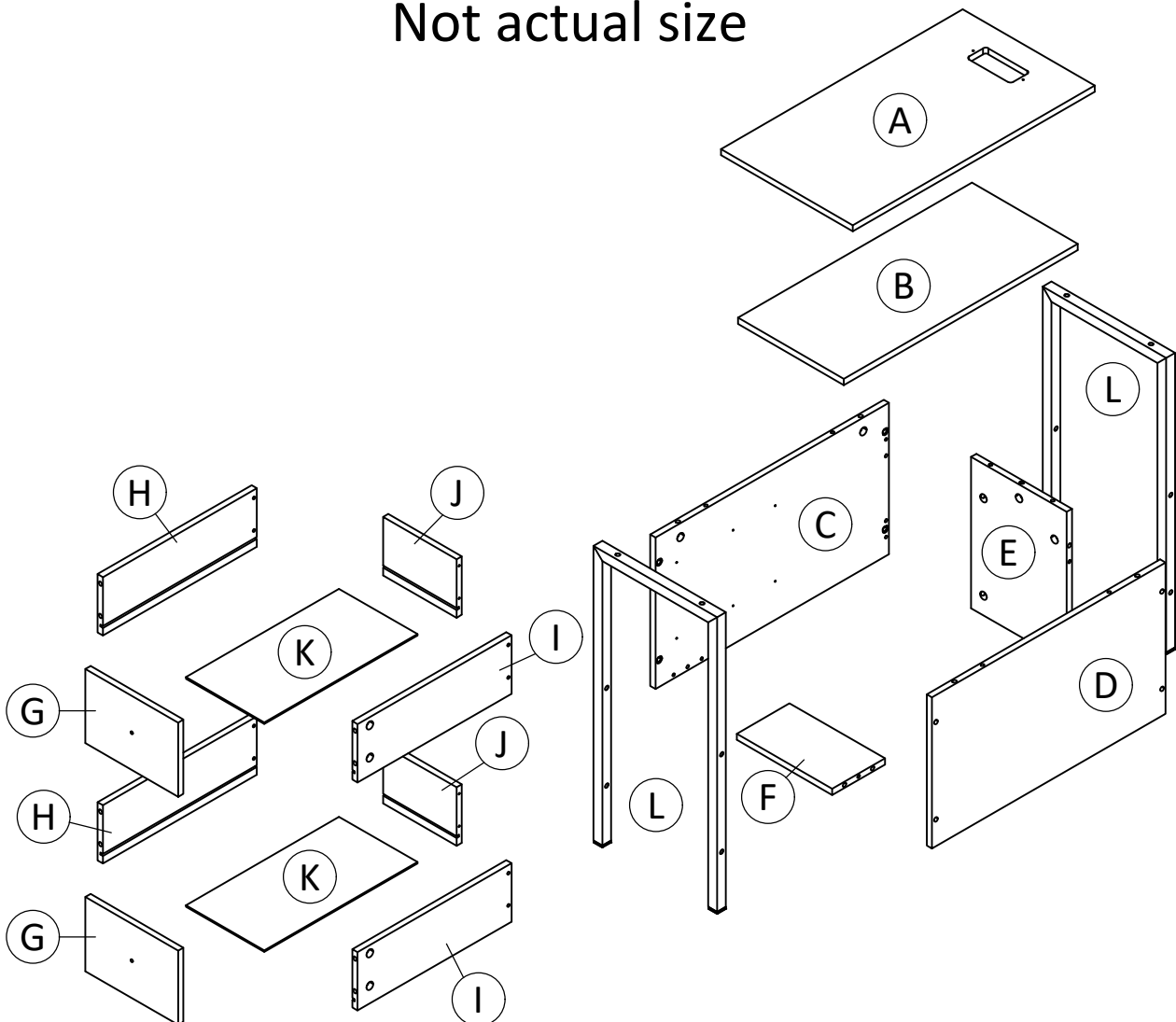

Part List

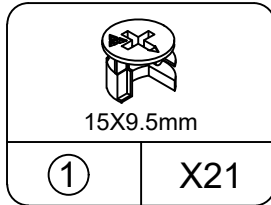

CAM LOCK
spare:1

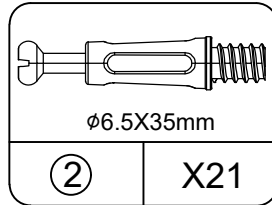

CAM BOLT
spare:1

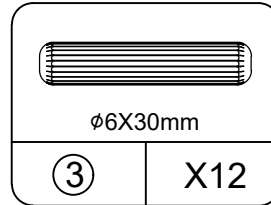

WOOD DOWEL
spare:1

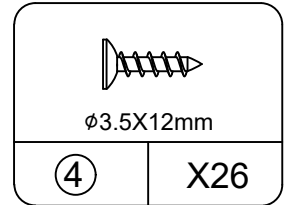

SCREW
spare:1

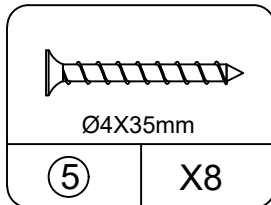

SCREW
spare:1

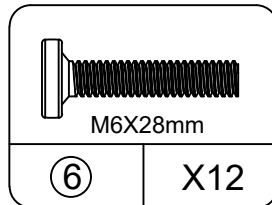

SCREW
spare:1

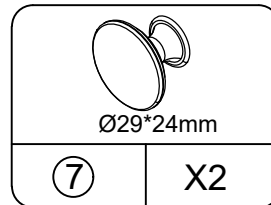

KNOB

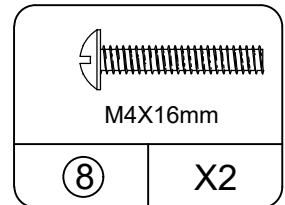

SCREW

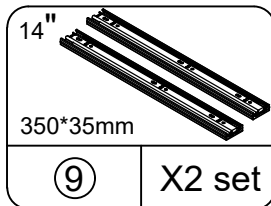

METAL SLIDE

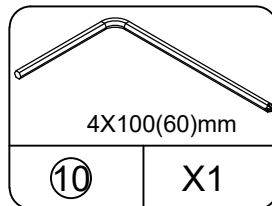

HEX KEY

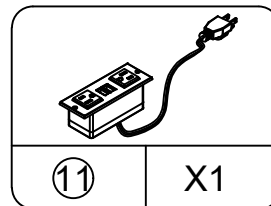

PLUG BOARD

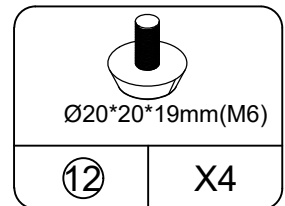

LEVELER

Cam Lock Fastening System

This Cam Lock Fastening System will be used throughout the assembly process.

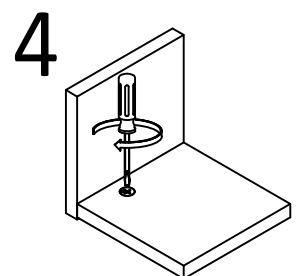
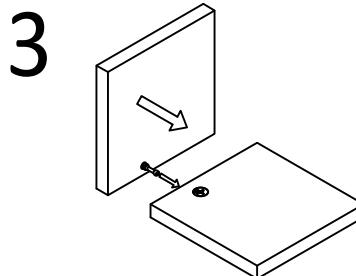
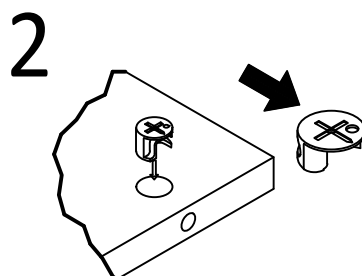
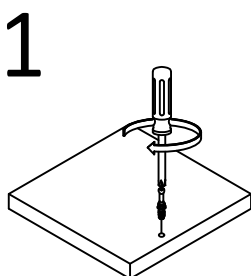

STEP1

How To SEPARATE BALL BEARING SLIDE. Cómo SEPARAR LAS GUÍAS DE BOLAS. Comment SÉPARER LES GLISSIÈRE À BILLES.

- 1) Pull toward arrow to open the slide until its stops and then flip it over.
Hale como indica la flecha hasta que la ranura se detenga y luego dele vuelta.
Tirez en direction de la flèche pour ouvrir la glissière jusqu'à ce qu'elle arrête, puis retournez la.

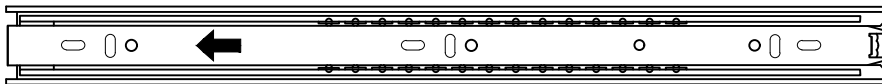

- 2) Push plastic lever down and pull apart.
Empuje hacia abajo el nivelador plástico y desmóntelo.
Poussez le levier en plastique vers le bas et séparez.

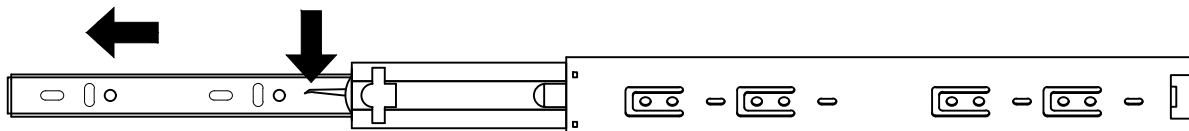

Cabinet member/ Nivelador del archivador/ Élément de l'armoire

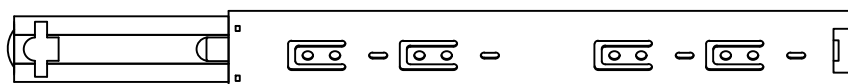

Drawer member/ Nivelador del cajón/ Élément du tiroir

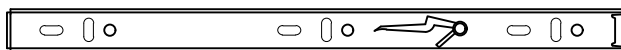

STEP 2

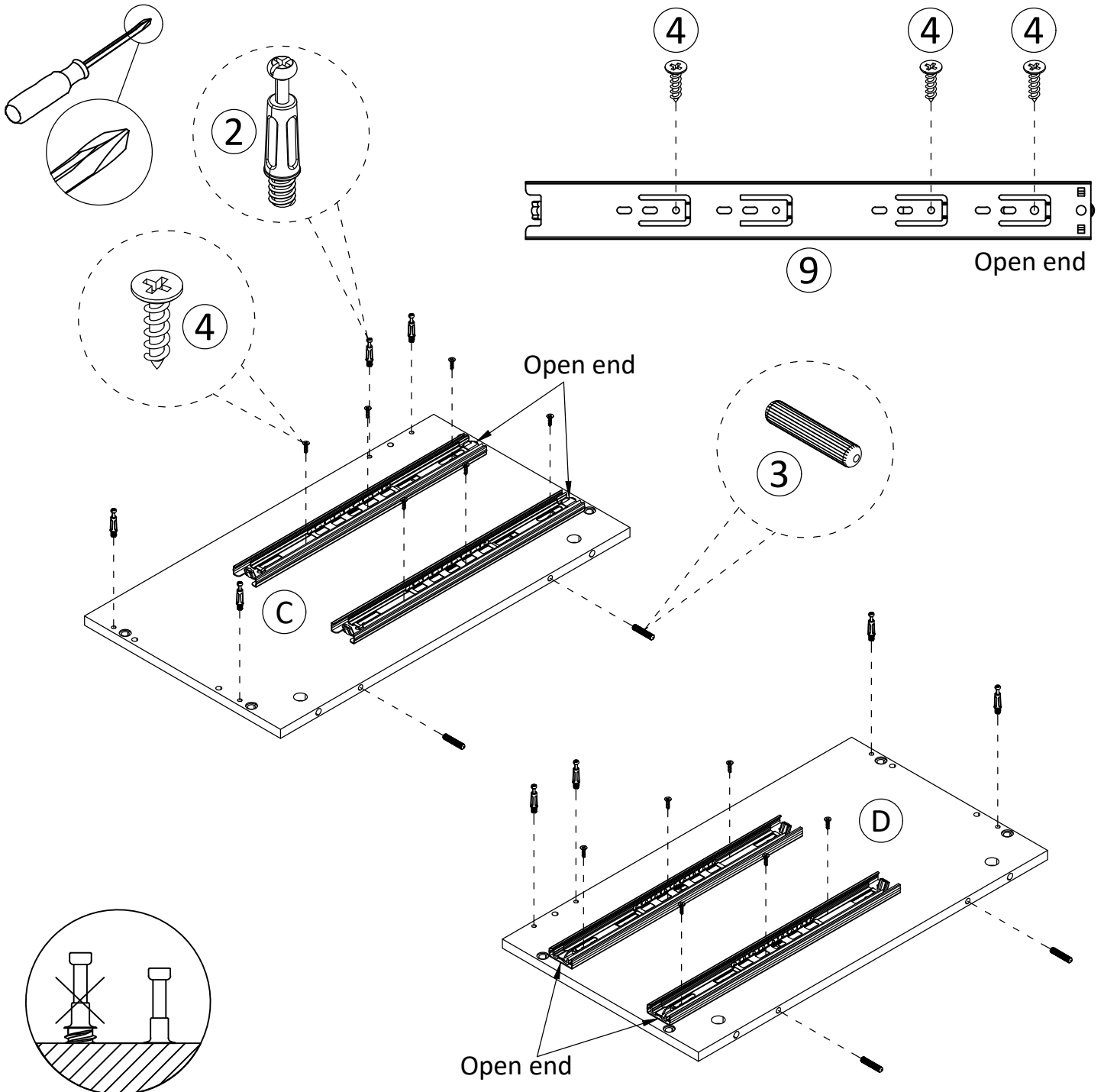
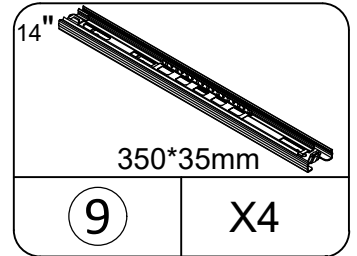
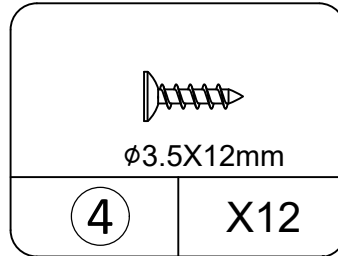
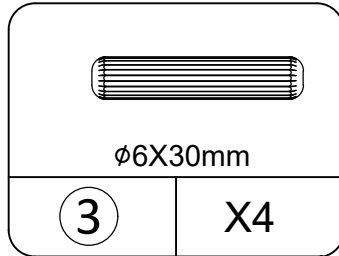
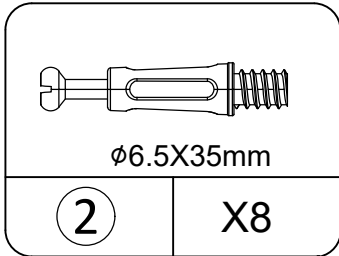

STEP 3

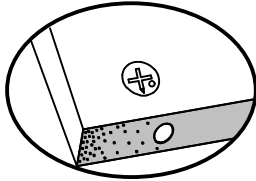
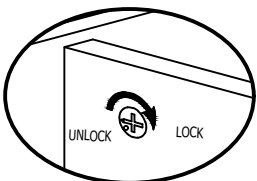
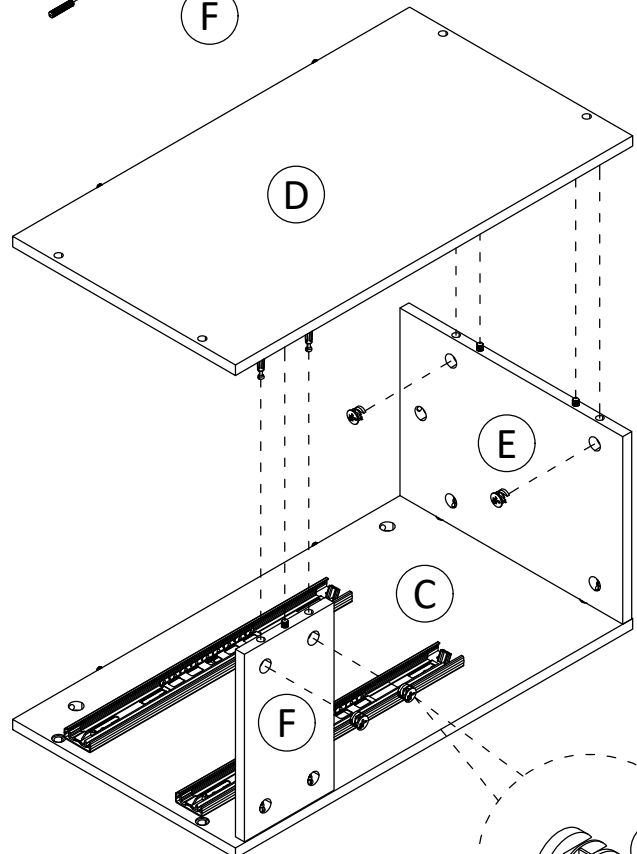
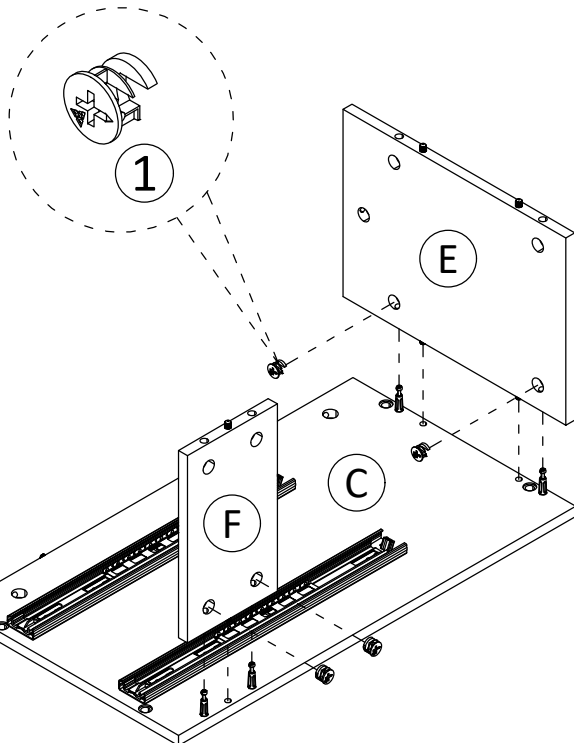
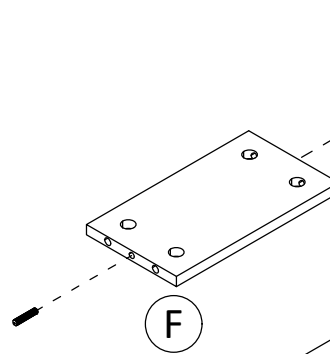
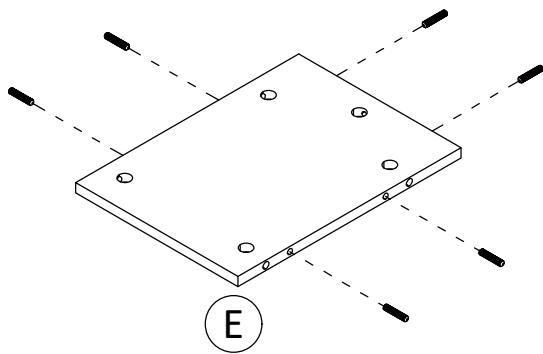
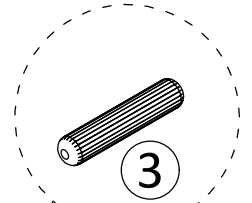
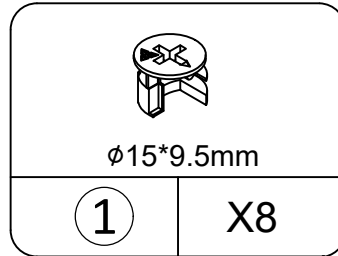
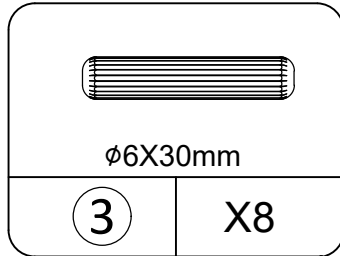
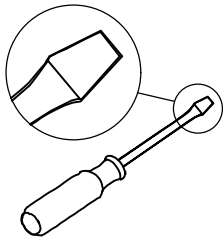

Proper orientation of CAM LOCK

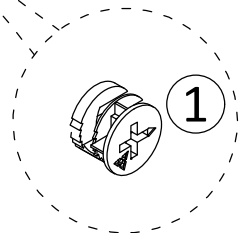

STEP 4

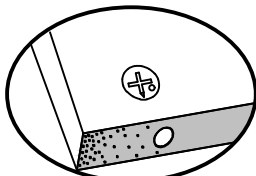
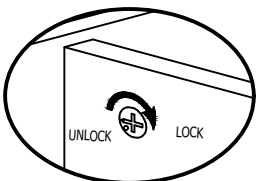
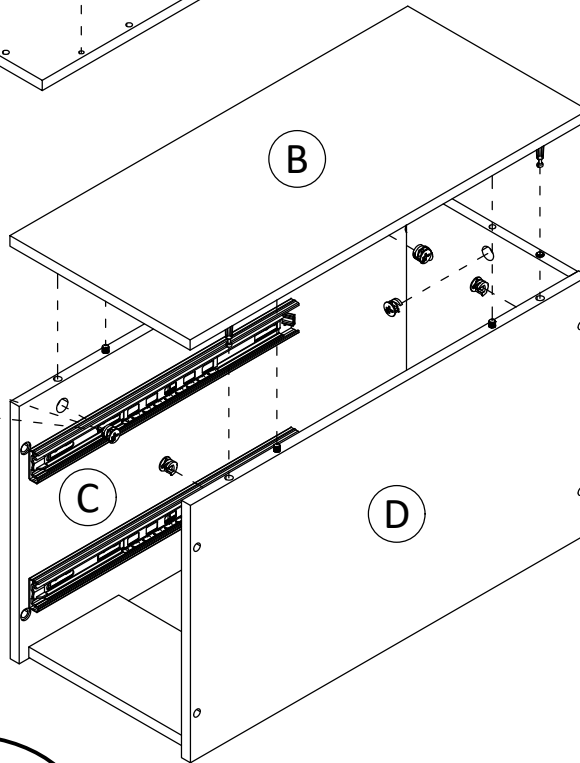
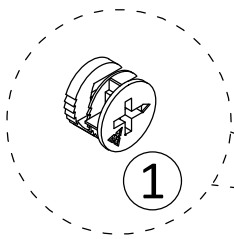
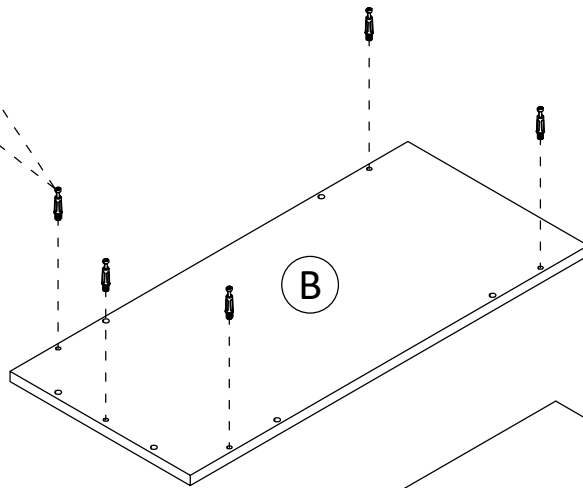
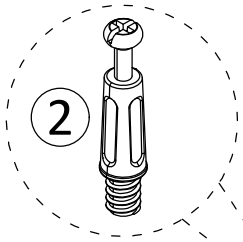
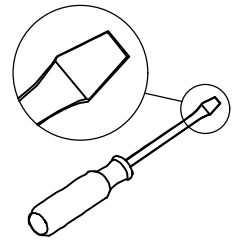
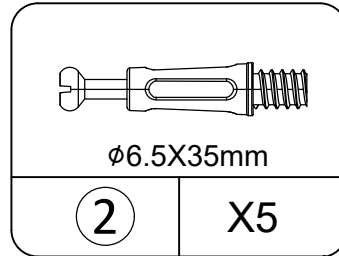
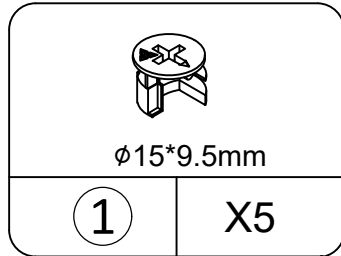
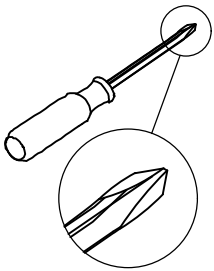

Proper orientation of CAM LOCK

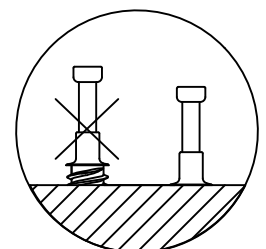

STEP5

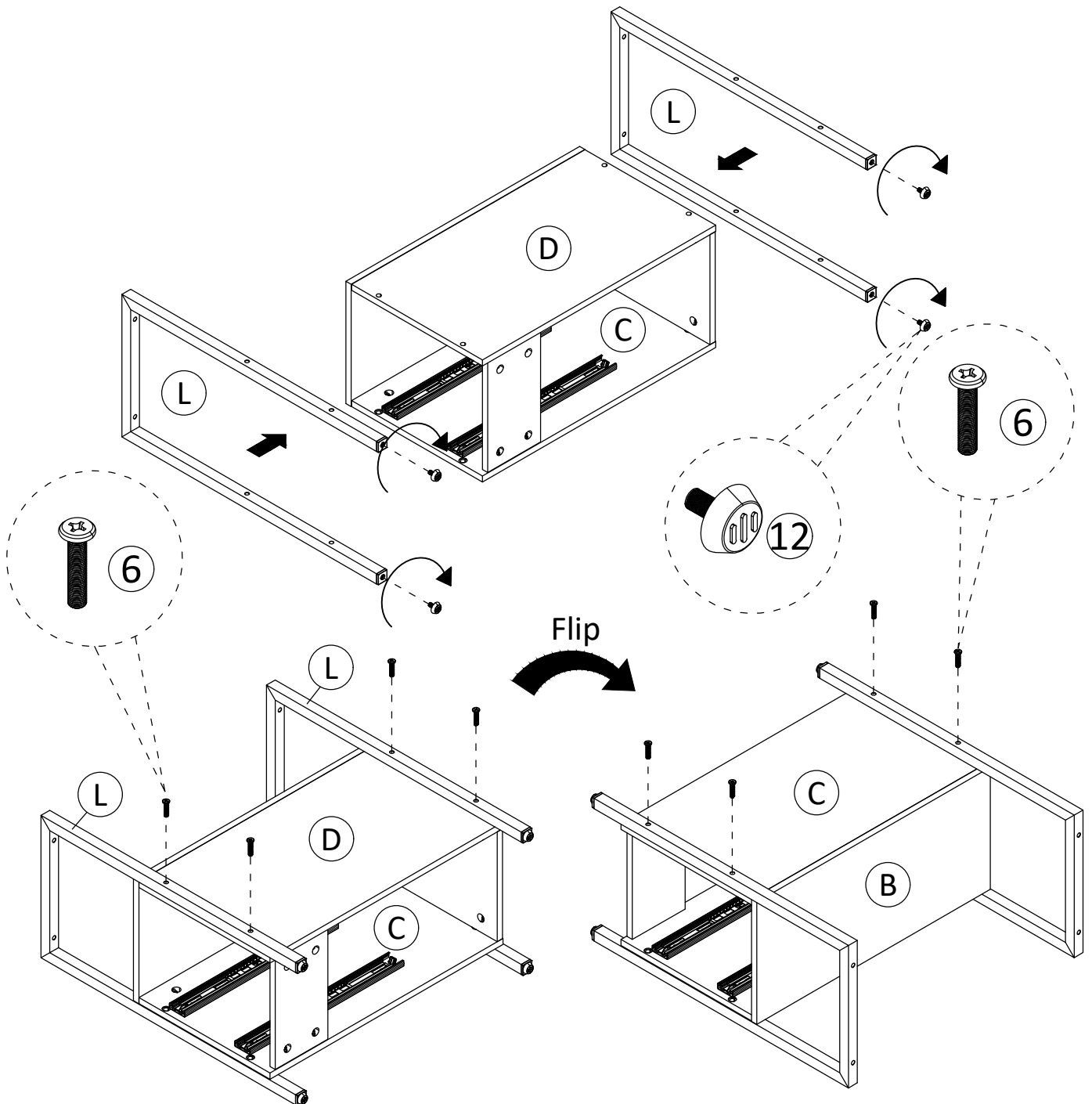
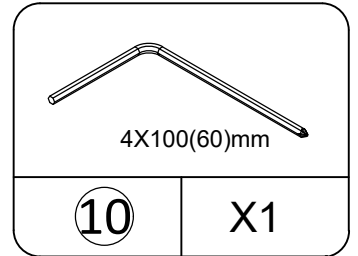
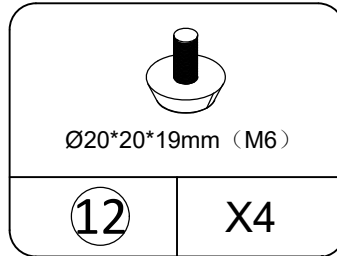
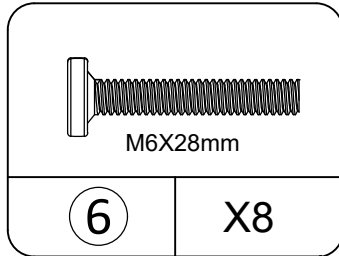
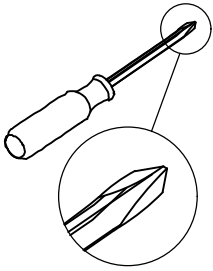

STEP 6

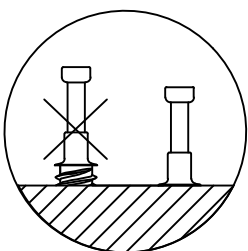
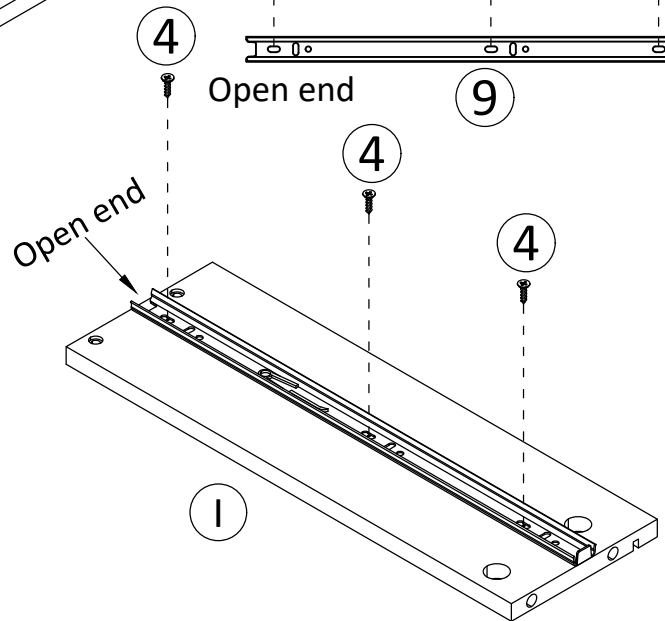
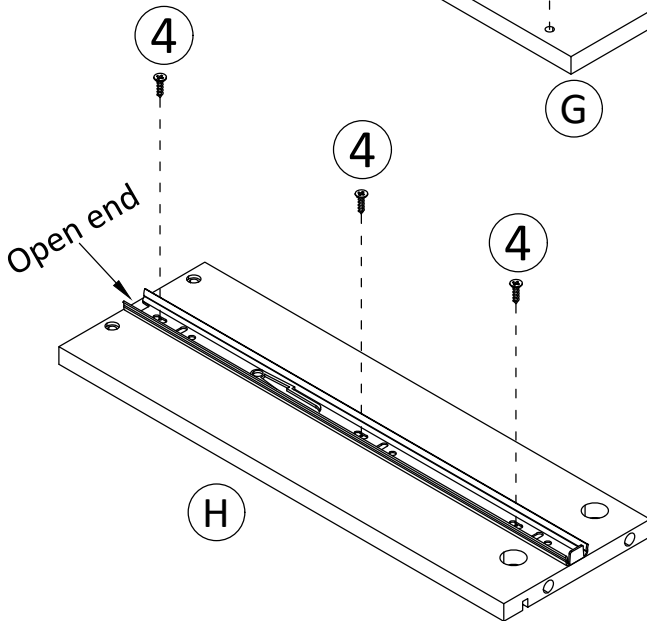
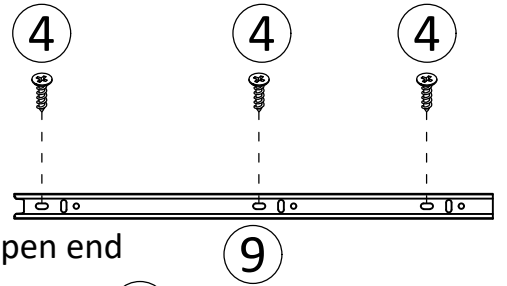
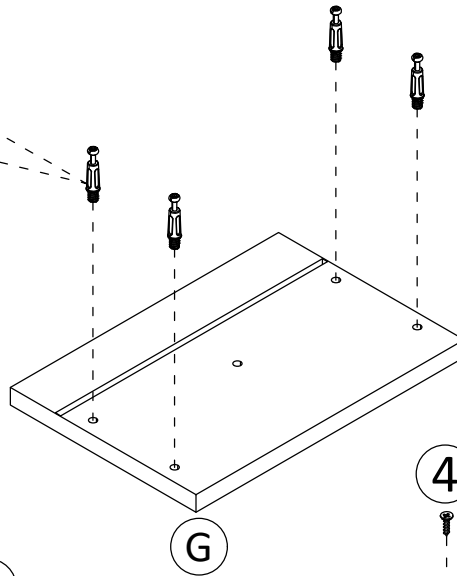
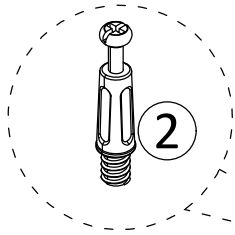
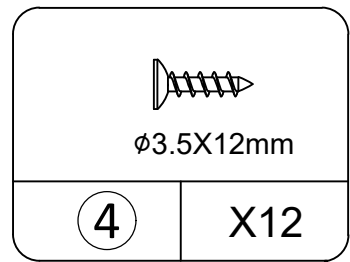
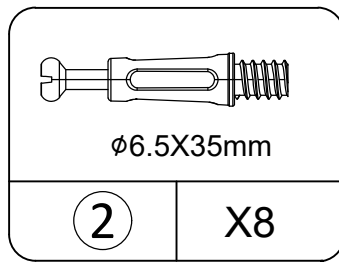
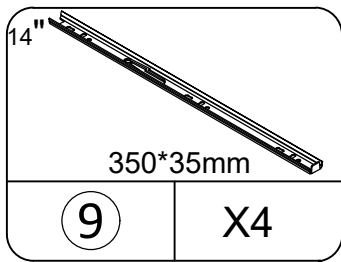
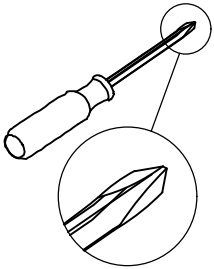

X 2

STEP 7

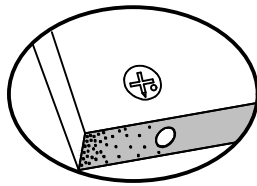
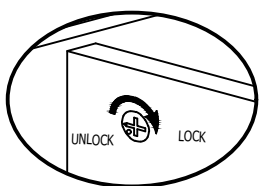
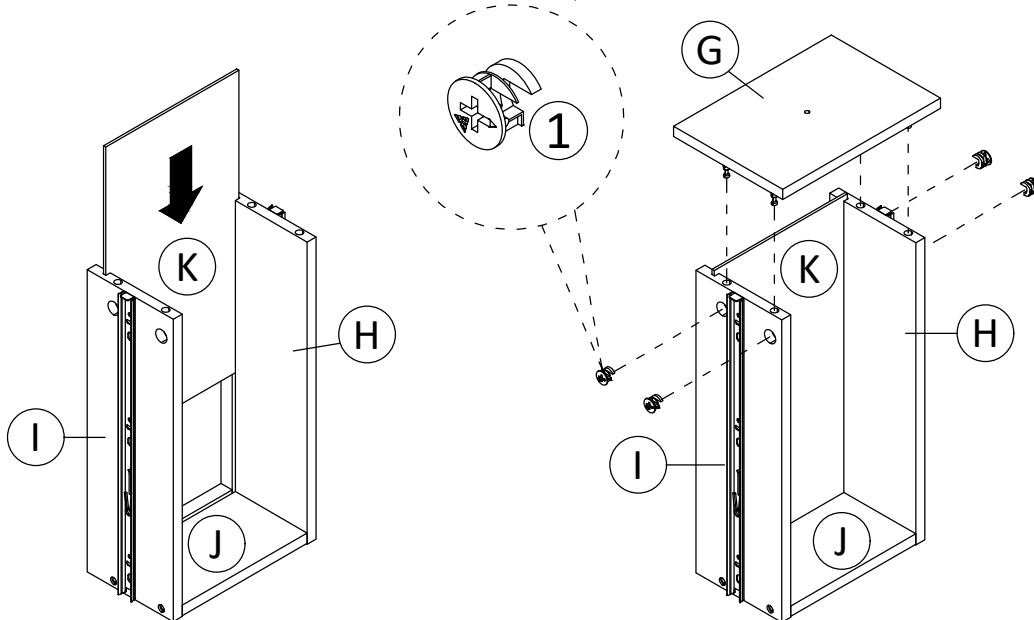
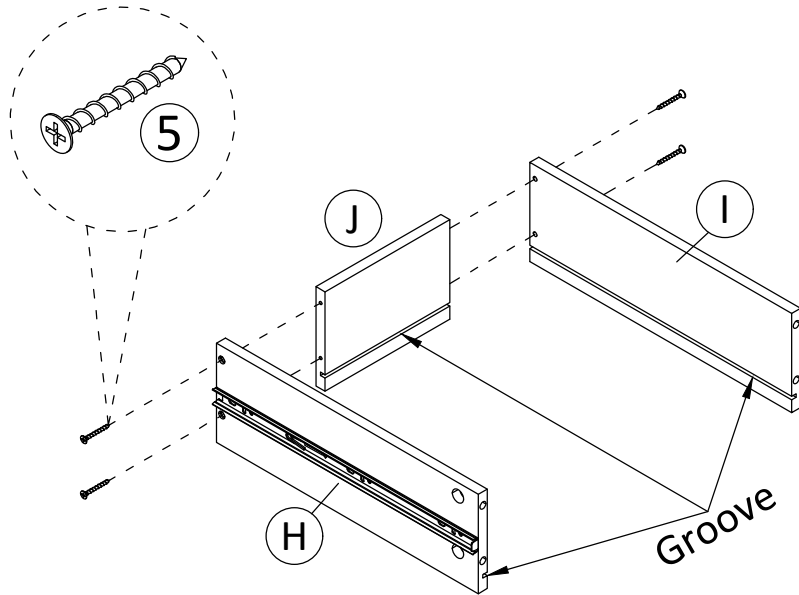
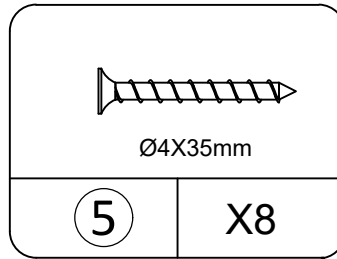
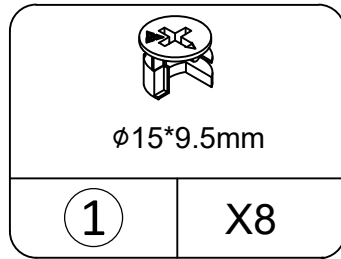
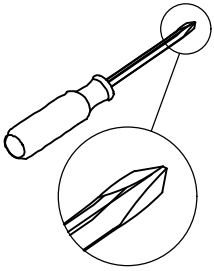

Proper orientation of CAM LOCK

X 2

STEP 8

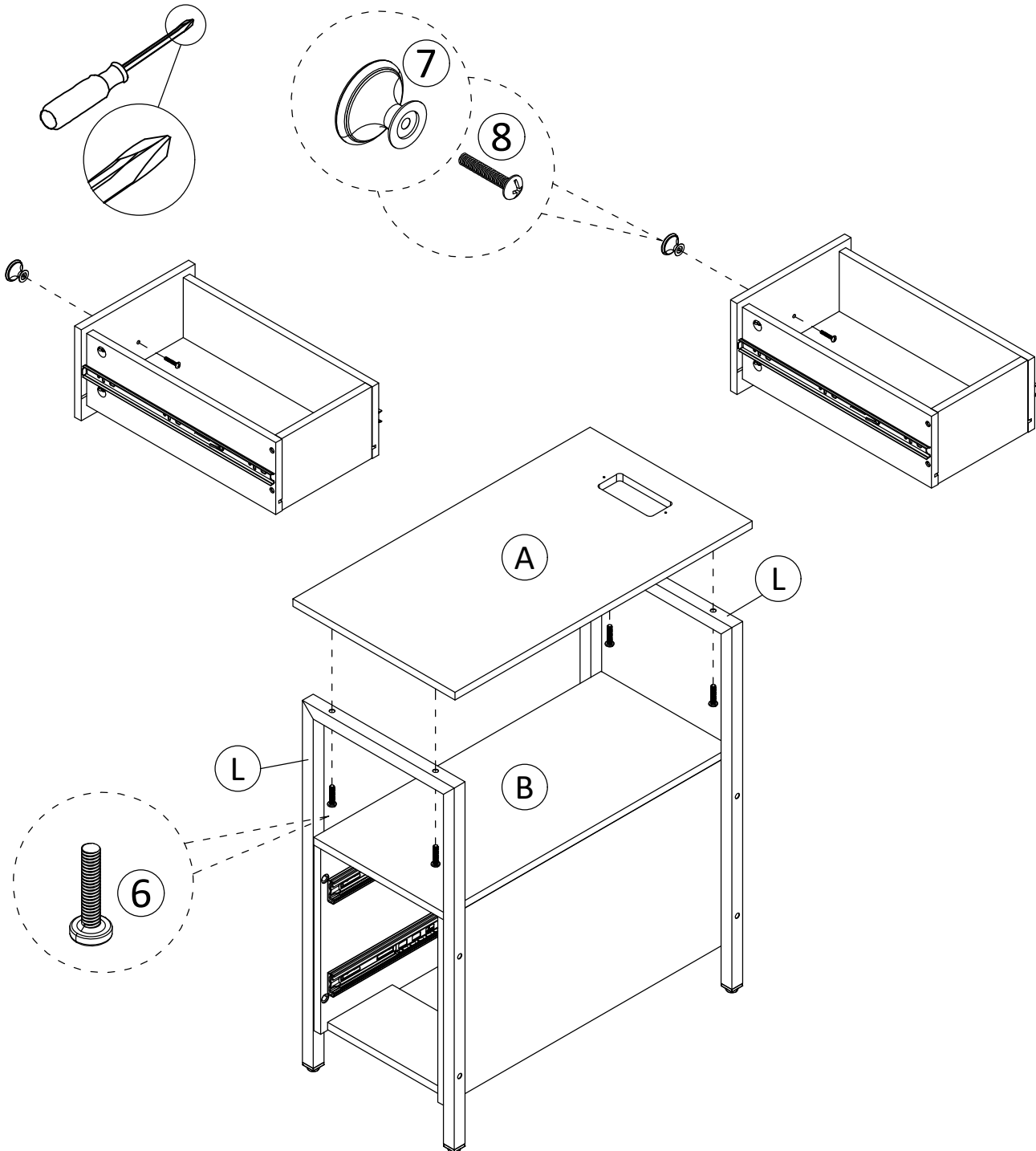
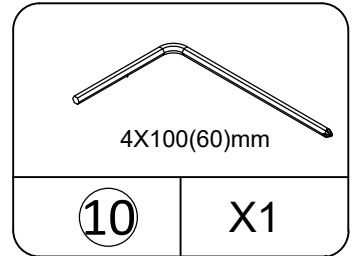
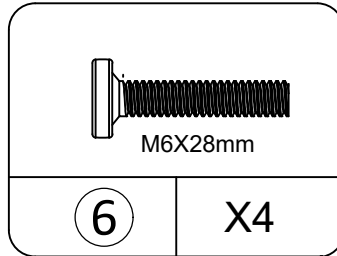
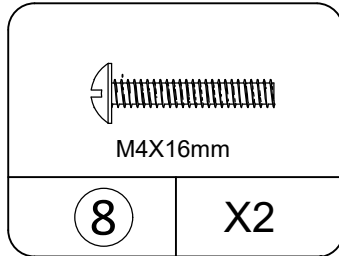
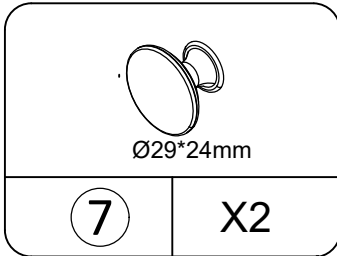

STEP9

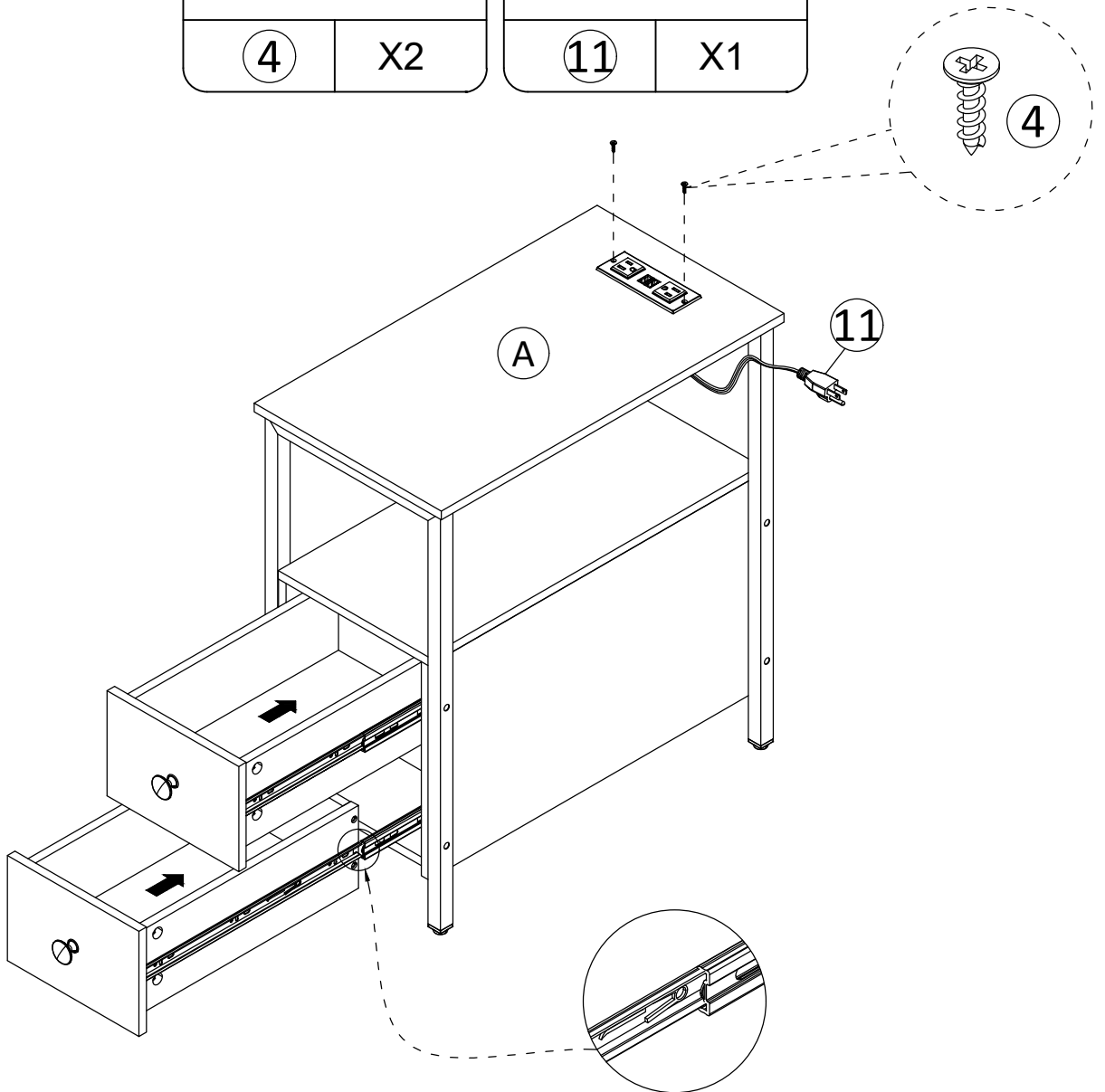
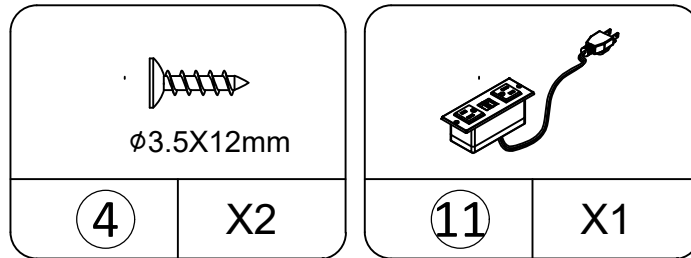

To Remove Drawer . If Needed

- Pull the drawer fully open so levers are visible.
- Push UP on left side lever and DOWN on rightside lever .
- Holding levers in place , pull drawer toward you.

