

# ASSEMBLY INSTRUCTIONS

## Table

ASSEMBLY  
REQUIREMENTS

2-Person  
Assembly

30 Minutes  
Assembly Time  
(Approximate)

Tools Required:  
(Not Provided)

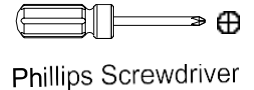
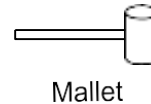

### Thank you for purchasing our product!

Please refer and use this assembly instruction to assemble the product. Contact our customer service department in case there are any missing or damage parts or hardware. Replacement parts are normally shipped within 2 or 3 days.

**PRODUCTS PURCHASED THROUGH OUR AUTHORIZED VENDORS ONLY ARE ELIGIBLE FOR REPLACEMENT PARTS**

We appreciate your business!

**THIS PRODUCT IS FOR INDOOR AND HOUSEHOLD USE ONLY  
– NOT FOR COMMERCIAL USE.**

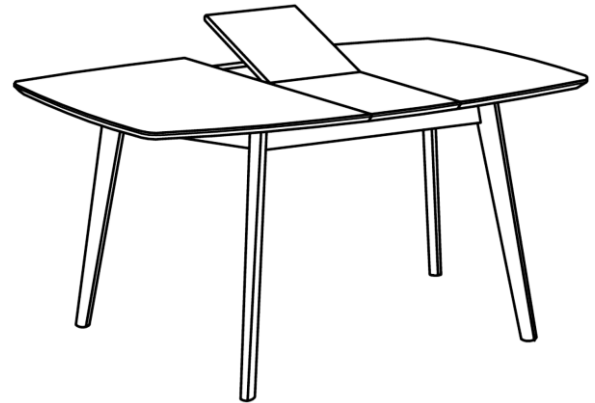

### ASSEMBLY PREPARATION

1. Remove all packaging materials, staples and packing straps from the carton.
2. Refer to Parts List and Hardware List, and ensure parts and hardware are correct before assembly. Contact customer service for missing parts.
3. Place all wooden parts on a clean, flat and soft surface (e.g. carpet or rug) to prevent scratch and damage to parts.

### SAFETY PRECAUTION

1. KEEP ALL HARDWARE PARTS OUT OF REACH OF CHILDREN.
2. DISPOSE PLASTIC PACKAGING MATERIAL IMMEDIATELY TO AVOID ANY RISK OF SUFFOCATION TO CHILDREN AND ANIMALS.

### TIPS FOR ASSEMBLY

1. Allow ample room for assembly and in close proximity to where product will be placed.
2. Assemble the product on a surface that does not scratch or damage the exterior gloss and finish of the furniture.
3. Identify all of the parts, hardware and quantities required for each step.
4. During assembly, do not over-tighten any fittings as this may cause damage.
5. DO NOT USE POWER TOOLS TO ASSEMBLE THIS PRODUCT.
6. Always place the product on a flat, level surface.
7. Do not sit or stand on the partially assembled product; only use the product for which it is intended.

### CARE AND MAINTENANCE

- Use a slightly damp cloth to clean the product. Do not use bleach or abrasive cleaning material.
- Check all the fittings periodically and re-tighten as necessary. Do not use the product if any of the parts is damaged or broken.
- Never allow any kind of liquid to remain on your furniture. Absorption can cause wood to warp or delaminate.
- Do not place hot items (e.g. hot drinks) directly onto the wood surface.
- Do not drag and/or pull the furniture.



# ASSEMBLY INSTRUCTIONS

## Table

### PARTS LIST

Item	Description	Qty
1	Table Top	1
2	Table Leg	4

### HARDWARE LIST

Item	Description	Part	Qty	Extra
A	JCBB M8 x 80mm + 5/16" x 20mm Spring & Flat Washer		8	1
B	Allen Key M5		1	
C	Leg Stud 5/8" With Pin		4	1

Extra hardware for spare use.

## STEP 1

**NOTE:** Please remove the screws and small blocks in this step. They are for shipping purpose only.

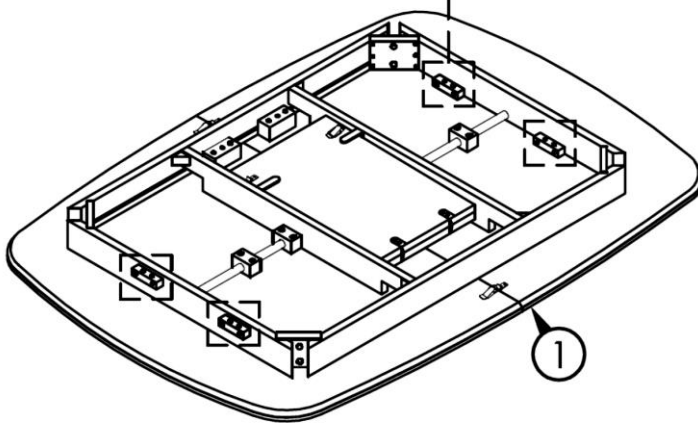
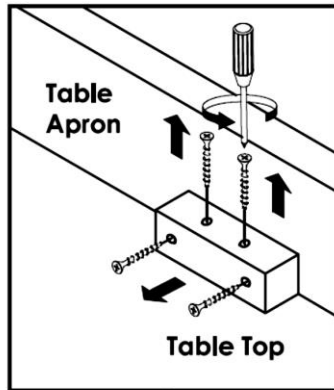

- With the assistance of another person, place Table Top (1) bottom-side up on a flat surface & soft material to prevent scratch and damage.
- Use Phillips screwdriver unscrew the screws and remove the small blocks as shown above.

## STEP 2

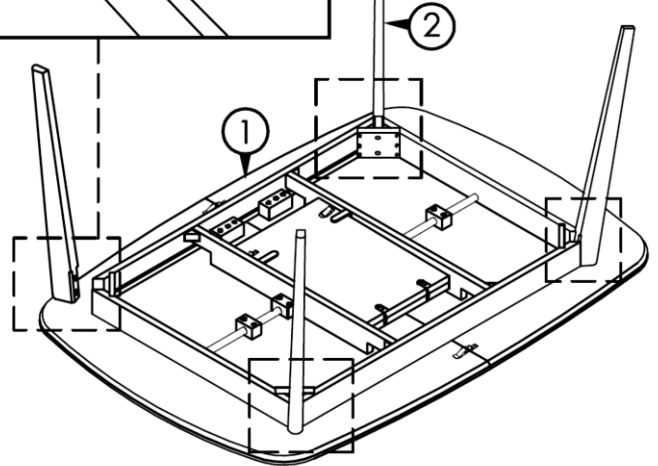
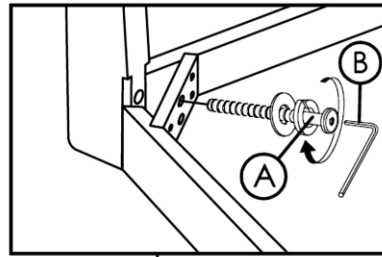

- Position Table Leg (2) against the corner of the table aprons and align the screw holes on (2) to the screw holes on the corner block.
- Insert Bolt (A) fitted with Spring Washer and Flat Washer through each hole at the corner block into screw hole on (2). Use Allen Key (B) to drive (A) to fasten Table Leg (2) at the corner block. Do not tighten (A) completely until both screws are in fixed on each leg. **Do not over-tighten.**

# Y INSTRUCTIONS

## Table

### STEP 3

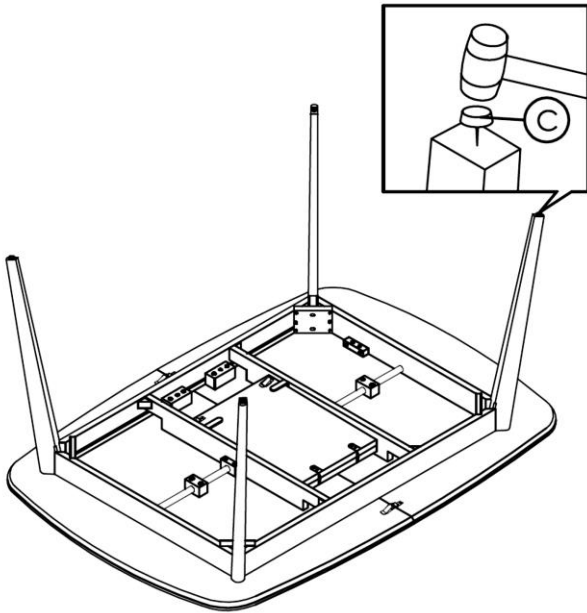

- Place Leg Stud (C) at the center of the bottom end of each leg and use a mallet to nail Leg Stud in each leg.
- With assistance, set the table right-side up.

### STEP 4

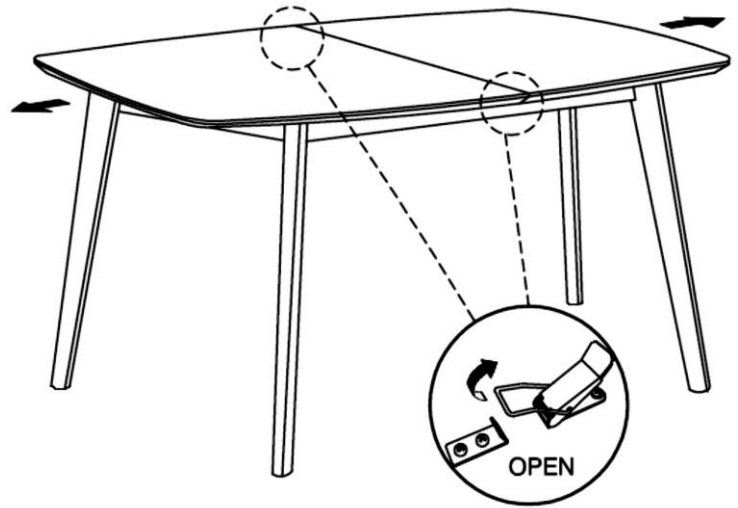

- Unlock both the side table lock underneath table top.
- Pull the two ends of the table top apart.

### STEP 5

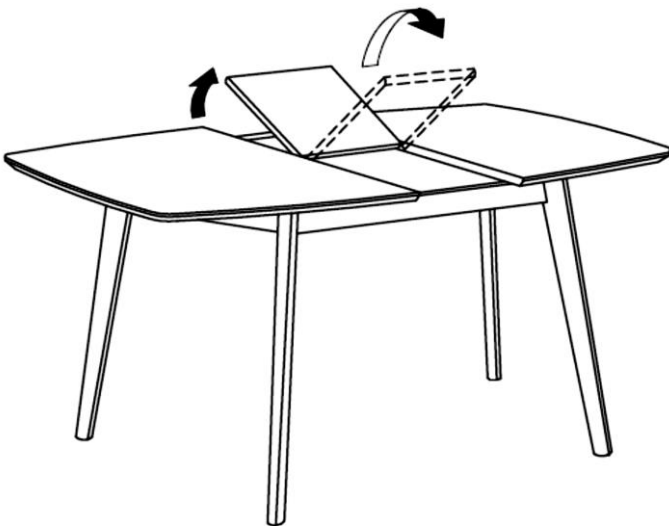

- Unfold the butterfly leaf in the center of the open table top as shown above.

### STEP 6

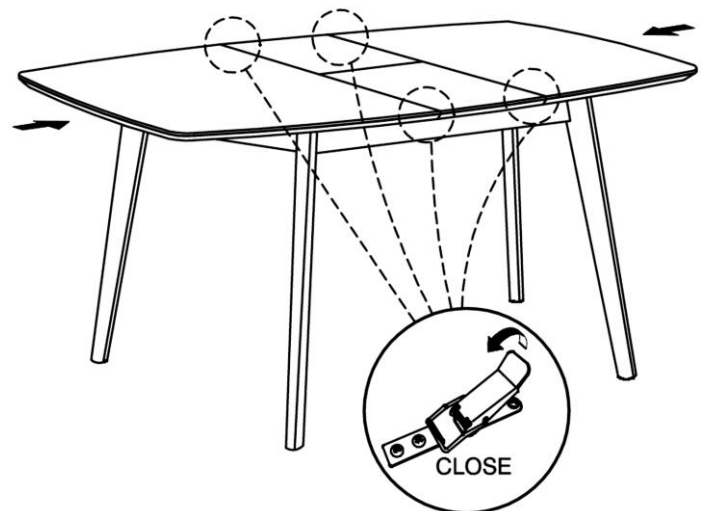

- Lower the flattened butterfly leaf at the center of table. Then push two end of the table top inward.
- Make sure all pin and holes aligned. Lock the table lock underneath all 4 sides of table top as shown above.

The assembly of the table is complete.