



AQUA MARINA



INFLATABLE FISHING BOATS

User's Guide

BT-88890
BT-88891
BT-88892



www.aquamarina.com

THANK YOU FOR CHOOSING AQUA MARINA FISHING SPORT BOATS



"Load your boat with fishes this summer with an AM CLASSIC fishing boat that has a place for everything!" The AM CLASSIC fishing boat offers great performance, durability and versatility. Best of all, it's so easy to set up and transport, simply put it in your car trunk and get some fishing fun!

This manual has been compiled to help you achieve long term safe use and pleasure from your Aqua Marina® boats.

GENERAL INFORMATION

SAFETY

In a manual of this type it is impossible to give adequate space to the topic of water safety. Check in your local area for information and/or training as needed. Inform yourself about local regulations and dangers related to boating and/or other water activities. It is your responsibility to be aware of and comply with all relevant safety regulations. For all water recreation or sport you should have a reasonable swimming ability. Just as swimmers have a cardinal rule about not swimming alone. It is strongly advised that you should never go boating alone.

PLEASE KEEP THIS MANUAL IN A SECURE PLACE, AND HAND IT OVER TO THE NEW OWNER WHEN YOU SELL THE CRAFT. RECORD THE "HULL IDENTIFICATION NUMBER" (HIN) WHICH IS PRINTED ON THE BOAT'S HULL IN THE FOLLOWING BOX:

CN-ORP

MANUFACTURER'S CERTIFICATION

This boat comply with ISO 6185 standard established by the International Organization for Standardization.

MANUFACTURER'S RECOMMENDATION

The total number of persons, motor power and total weight shall not exceed the limits labeled (Fig.1) on the boat.

①	EN ISO 6185 PART1 TYPE II DESIGN CATEGORY C	STANDARD EN ISO 6185-1:2018	
	Do not over inflate or use high pressure air compressor to inflate. Adults should inflate the chambers in numbered sequence. Inflate the chambers in numbered sequence. Use the enclosed barometer to check while inflating. Ensure even distribution of persons or loads in the boat. Fill with cold air only.	BOAT TYPE TYPE II	
	WARNING: This is not a life-saving device. Use only under competent supervision. Always use an approved life preserver. Do not use in high wind, rapid currents, open water or dangerous tides. Be familiar with the area where you intended to use the boat. Never allow diving into or from this boat. Never leave in or near the water when not in use. Follow these rules to avoid drowning, paralysis or other serious injuries. - Not for use by children without adult supervision. - Do not overload. - Not for whitewater use. - The leakage of battery acid is dangerous. - Know and follow local water safety rules and boat regulations. - The weight shall be evenly distributed in the boat.	DESIGN CATEGORY C	
		BOAT MODEL BT-88890	
		③	③
		④	④
		⑧	⑧
		⑤	⑤
		⑥	⑥
		CN-ORP	⑦
②	MADE IN CHINA DATE	CE	
		ORIENTAL RECREATIONAL PRODUCTS (SHANGHAI) CO., LTD NO. 1688 DAVEY ROAD, WUJIAO, FENGGUAN, SHANGHAI, 201402, CHINA	

Fig.1

1. As per Directive 2013/53/EU boat design category
Design Category D "SHELTERED WATERS" Designed for voyages on sheltered coastal waters, small bays, small lakes, rivers and canals when conditions up to, and including, wind force 4 and significant wave heights up to, and including, 0,3 m may be experienced, with occasional waves of 0,5 m maximum height, for example from passing vessels.
2. Country of origin
3. Maximum person's capacity
4. Manufacturer's recommended maximum load capacity
5. Manufacturer's recommended working pressure
6. Hull identification number (HIN)
7. CE mark, manufacturer's name and address
8. Maximum motor power

SAFETY CHECK LIST & SAFETY WARNING

- Always wear an approved Personal Flotation Device (Life Preserver)
- Be aware of your local boating rules and regulations and abide by them accordingly
- Check inflation levels each time before you go out and inflate your boat for a full 24 hours before undertaking long trips
- DO NOT allow children to use Aqua Marina unsupervised
- DO NOT consume alcohol while boating or operating a boat while under the influence of alcohol or drugs
- DO NOT drag your Aqua Marina over rocks or gravel if it can be avoided
- DO NOT exceed the certified maximum capacities of this boat under any circumstance
- DO NOT go boating alone
- DO NOT use compressors, CO₂ or compressed air for inflation, only use Aqua Marina recommended pumps
- DO NOT use your Aqua Marina Boat as a personal flotation device as they are designed for leisure/recreation in mind
- DO NOT sleep inside of your Aqua Marina while on the water

SPECIFICATIONS AND FEATURES

SPECIFICATIONS

Items Models	Size	Max passenger	Air chambers	Air pressure	Standard Max. payload	Max. payload with optional plywood deck	Net weight	Max. motor power
BT-88890	9.8'x4'6" (300x134cm)	4	2+1	0.12 bar hull	400kg (880lbs)	430kg (946lbs)	18.9kg (41.7lbs)	3KW (4HP)
BT-88891		3+1			380kg (836lbs)	410kg (902lbs)	17kg (37.5lbs)	500W
BT-88892					20kg (44.1lbs)			

STANDARD EQUIPMENT

Items Models	Carry bag	Aluminum oar	11" Foot pump	Repair patch	Pressure gauge	Wooden bench seat	Motor /Motor Mount
BT-88890	1 pc	1 pair	1 pc	1 set	1 pc	1 pc	Gas motor mount
BT-88891							Trolling motor mount
BT-88892							With T-18 trolling motor

DESCRIPTION

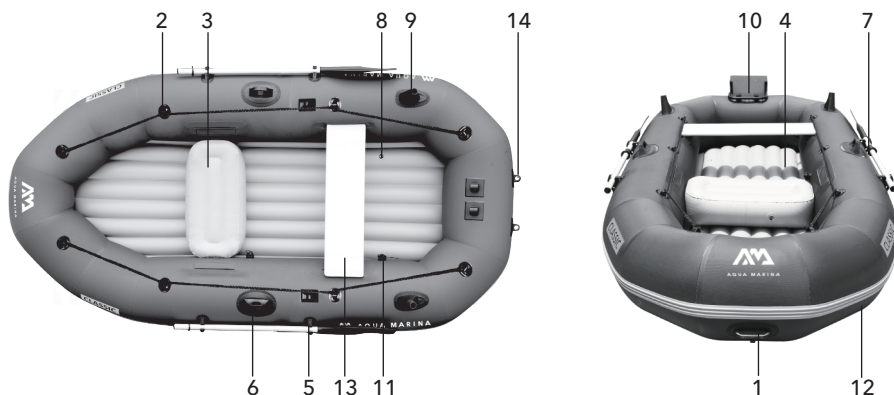

NOTE: Drawings for illustration purpose only. Actual product may vary. Not to scale.

1	Bow carry handle	2	Grab line	3	Inflatable cushion seat
4	Inflatable I-beam floor	5	Oar lock	6	Oar holder
7	Aluminum oar	8	Inflation valve	9	Fishing rod holder
10	Motor mount (for BT-88890)	11	Boston screw valve	12	Rubbing strake
13	Wooden bench seat	14	Electric motor mount (for BT-88891 and BT-88892)		

SET UP INSTRUCTION

UNFOLD THE BOAT

Choose a smooth and clean surface to spread the boat out so that the inflatable chambers can fill easily.



BOSTON SCREW VALVE OPERATION

Follow the instructions below for valve operation and correct inflation and deflation procedures.

1. Double valve cap (valve lets air in, not out). (Fig.1)
2. Quick deflation cap. (Fig.2)
3. Unscrew the double valve cap. (Fig.3)
4. Insert the output end of air pump into the valve and fill. (Fig.4)
5. To deflate, unscrew the quick-deflation cap. (Fig.5)

CAUTION: Double valve does not operate when the cap is off. Do not unscrew this cap while boat is in the water.



Fig.1&2

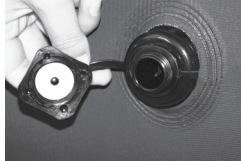

Fig.3



Fig.4



Fig.5

INFLATION VALVE OPERATION

1. Open external cap and pull firmly to extend out. (Fig.1)
2. Attach suitable adapter nozzle to inflation end of pump. Insert pump and start to pump. (Fig.2)
3. When fully inflated, gently twist adapter sleeve to right while backing pump out of valve.(Fig.3)
4. Fully remove adapter and close external stopper. Valve should appear depressed into itself. (Fig.4)



Fig.1

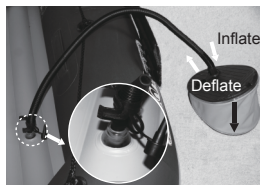

Fig.2



Fig.3



Fig.4

INFLATION STEPS

1. Inflate the chambers following the numerical sequence marked on the valves. It is very important to follow the numerical sequence; failure to do so will result in an improper inflated boat.
2. Inflate the hull. After inflation, insert the provided pressure gauge into the air valve to check the air pressure. Ideal pressure is 1.45psi-0.10bar.
3. Inflate the floor until it is stiff to the touch but NOT hard.

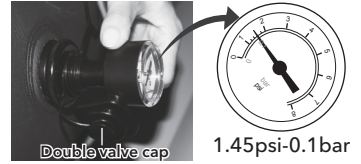

1.45psi-0.10bar

IMPORTANT!

Please use the transparent scale (come with the repair kits bag) to check if the air floor is properly inflated. The black line on the floor should NOT be longer than the MAX. scale.

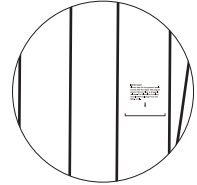

NOTES: Check the pressure every time before usage. Air temperature and weather condition do affect the internal air pressure of inflatable products. In cold weather the product will lose some pressure due to the fact that the air will contract. If this occurs, you may want to add a little air to the product. However, in hot weather, the air will expand. You must let some air out to prevent the product from failing due to overpressure.

- Only use Aqua Marina® approved inflation pumps
- Never use motor-driven high-pressure air pumps as this may result in over-inflation. Fill with cold air only
- Under and over-inflation will result in safety hazards
- Always check the inflation pressure before using the boat
- Never stand on or rest objects on the boat during inflation
- Never open the cap of air valve while the boat is in use
- Be sure the valve is tightly closed before using the boat

HULL ASSEMBLY

1. Wooden bench seat installation

Slide the seat into position by inserting the flaps on both chamber of the boat into notches on the Seat Board.

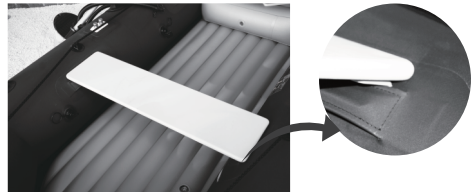

2. Motor mount installation (for BT-88890)

- Put straight tubes of the motor mount onto the boat fitting holes. (Fig.3.1)
- Put upper tubes of the motor mount onto the boat fitting holes. (Fig.3.2)
- Adjust to make sure the motor mount fits boat in place and firmly. (Fig.3.3)

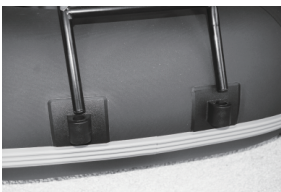

Fig.3.1



Fig.3.2



Fig.3.3

3. Electric motor installation

- Release the small adjustable tension collar from electric motor.
- Put stainless steel pipe into the upper and the lower buckle of the boat stern.
- Adjust to make sure the motor fits boat in place and firmly.
- Fix the tension collar and tighten it.

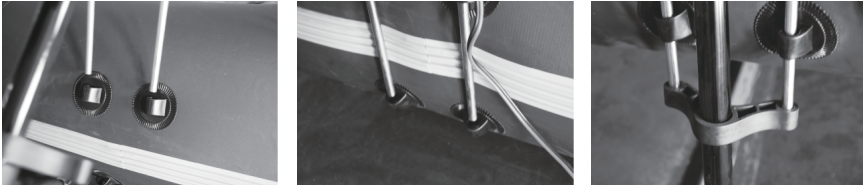

4. Fishing rod holder use (Fig.4)

- Slide the end cap over the end of the fishing rod
- Insert the fishing pole into the holder

OUTBOARD MOTOR INSTALLATION

After the boat is fully inflated and well assembled, attach your outboard motor onto motor mount at the center.

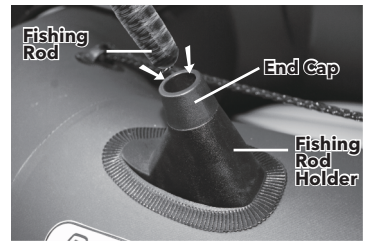

Fig.4

NOTE:

- Ensure the motor is always fixed on the motor mount
- Read the instruction of outboard motor for correct installation and operation
- Overpowering a boat can result in serious injury, death or boat damage. Find the maximum motor power marked on the boat label

OAR ASSEMBLY

1. Insert "Shaft A" through the oar-lock first.
2. Insert "Shaft A" with the pin end into "Shaft B" with the blade towards outboard (water)
3. Double check and make sure the retainer ring onto the other end of the "Shaft A", from inside of the boat.
4. When the oars are not in use secure the oars onto the oar holders located on each side of the boat.

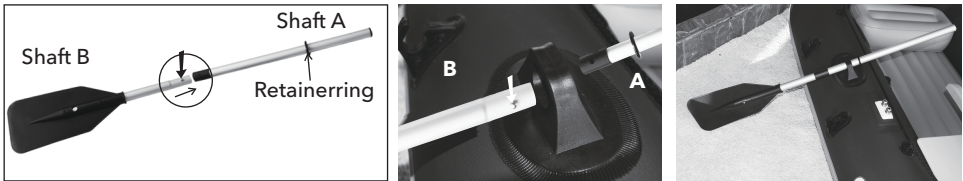

PRODUCT CARE AND STORAGE

The boat is made of the highest quality materials and complies with ISO 6185 standards. Altering the construction of the boat will endanger your own safety, safety of the occupants and void the limited warranty!

There is very little that you have to do to keep your boat in good condition for many years.

- When landing on the shore, carry the boat. Do not tow it on the sand or ground as damage may occur
- If you use the tow rings to tow the boat, go slowly to avoid over-towing as damage may occur
- Clean your boat after a trip to prevent damage from sand, salt water or sun exposure. Most dirt can be removed with a garden hose, a sponge and mild soap. Make sure the boat is completely dry before storing. Use as few cleaning agents as possible, do not discharge waste agents into water, and clean your boat preferably on land
- Be sure your product is completely dry before storing
- The products may be stored inflated, but do not place any heavy or sharp objects on it. Hanging the boat is not recommended
- Open all air valves and deflate boat completely. Remove all the accessories from the boat; seats and oars
- Fold the bow end twice to the middle of the boat tightly while forcing out any remaining air; repeat this procedure for the stern. The boat storage bag is designed to allow you to get your boat into the bag as easily as possible with minimal folds.

Follow the diagram below for the best folding procedures:

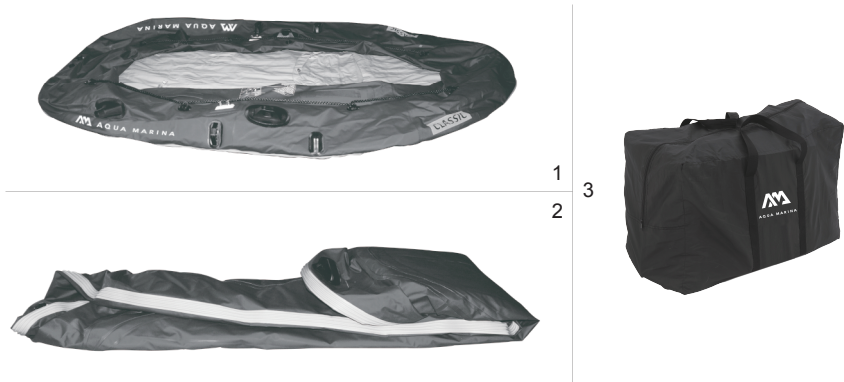

- Storage is best in a dry room. Ensure protection against rodents and other vermin, as they feed on the fabric of the canoe
- Store the product and accessories in a dry, temperature controlled, between 32 degrees Fahrenheit (0 degrees Celsius) and 104 degrees Fahrenheit (40 degrees Celsius) storage location

LEAK DETECTION AND REPAIR

AIR LEAK DETECTION

If your boat appears a bit soft, it might not be because of a leak. If the boat was inflated late in the day with 32°C (90°F) air, that air might cool down to 25°C (77°F) overnight. The cooler air exerts less pressure on the hull, so it could appear soft the next morning. If there has been no temperature variation, you need to start looking for a leak:

- Take a good look at your boat from just a few feet away. Flip it over and closely check over the outside. Any large leaks should be clearly visible
- If you have an idea where your leak is, use a mix of dishwashing liquid and water in a spray bottle, and spray over the suspicious areas. Any leak will produce bubbles that will pinpoint the location of the leak
- Check valves for leak, if necessary, spray soapy water around the valve and the valve base

SMALL REPAIRS

Inadvertent punctures can be repaired using included vinyl repair patch. You can purchase additional PVC or silicon based glue for repairing camping mats, tents or shoes from your local market to patch your boat. Please refer to the instruction of the glue for patching.

1. Thoroughly clean and dry the damaged area. Completely deflate the product.
2. Cut a portion of the patch to cover the puncture and allow an additional 1/4" on all sides. Always cut a round patch, never leave square corners.
3. Be sure the repair area is completely dry.
4. Apply generous coat glue to the vinyl repair patch and to the product.
5. Allow the glue to dry for 2 to 3 minutes, or until the glue becomes tacky.
6. Apply the patch to the product, using your thumb or finger; apply even pressure across the entire surface of the patch. Make sure the edges of the patch are pressed down along the entire diameter.
7. Allow the product to dry for at least 12 hours before inflating and using. If there are large tears/cracks, please bring the water craft or any essential equipment part into a professional repair shop for appropriate repair or replacement.

WARRANTY

AM warrants this product to be free from major defects in material or workmanship to the original purchaser for a period of SIX (6) Months from the date of purchase. This warranty is subject to the following limitations:

1. The warranty is valid only when this product is used for normal recreational activities and does not cover products used in rental or school operations
2. AM will make the final warranty determination, which may require inspection and/or photos of the equipment, which clearly show the defect(s). If necessary, this information must be sent to the AM distributor in your country with prepaid postage. Product can be returned only if a return authorization number is given in advance by the AM distributor.
The return authorization number must be clearly labeled on the outside of the package, or it will be refused
3. If a product is deemed to be defective by AM, the warranty covers the repair or replacement of the defective product only. AM will not be responsible for any costs, losses, or damages incurred as a result of loss or use of this product
4. This warranty does not cover damage caused by misuse, abuse, neglect, normal wear and tear including, but not limited to, punctures, damage due to excessive heat exposure, damage caused by improper handling and storage, damage caused by use in waves or shore break, board breakage caused by filling or crashing in surf conditions, or damage caused by anything other than defects in material and workmanship
5. This product must not be modified and/or fitted with a motor
6. This product must not be used in excess of the manufacturers recommended maximum load capacity
7. This warranty is void if any unauthorized repair, change or modification has been made to any part of the equipment
8. The warranty for any repaired or replacement equipment is good from the date of the original purchase only
9. The original purchase receipt must accompany all warranty claims. The name of the retailer and date of purchase must be clear and legible
10. There are no warranties that extend beyond the warranty specified here in



This product is designed in accordance with standards for a specific use. Any modifications or transformations higher than that indicated by the manufacturer could result in serious risks for the user and will void the warranty.