

Extendable Kitchen Island

Assembly Instructions - Please keep for future reference

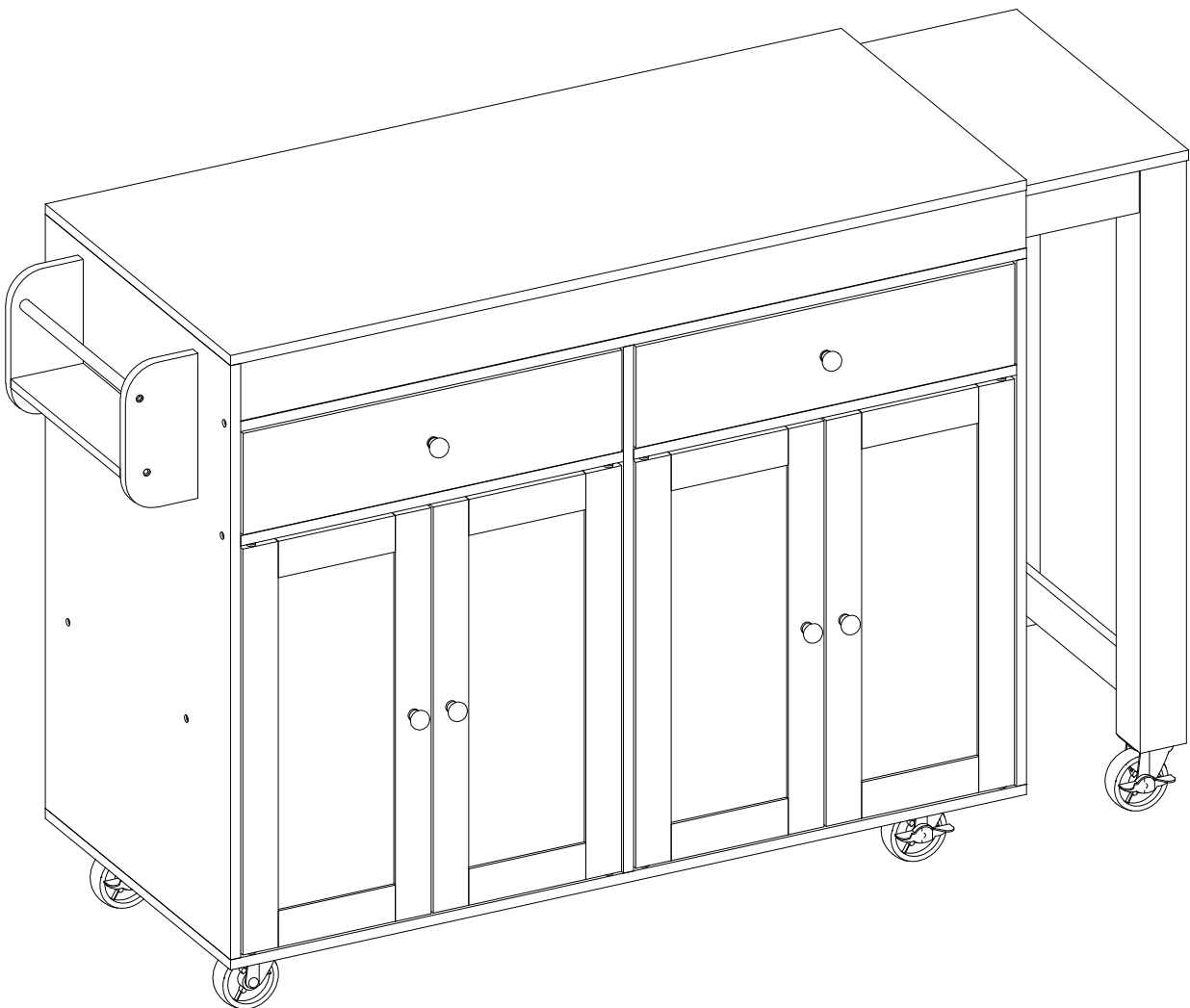

Important - Please read these instructions fully before starting assembly



Safety and Care Advice

Important – Please read these instructions fully before starting assembly

- Check you have all the components and tools listed on the following pages.
- Remove all fittings from the plastic bags and separate them into their groups.
- Keep children and animals away from the work area, small parts could choke if swallowed.
- Make sure you have enough space to layout the parts before starting.

- During assembly do not stand or put weight on the product, this could cause damage.
- Assemble the item as close to its final position (in the same room) as possible.
- Assemble on a soft level surface to avoid damaging the unit or your floor.
- Parts of the assembly will be easier with 2 people.



power drill is set on a low torque setting.

- To reduce the likelihood of damaging your product please ensure that your

Care and maintenance

- Only clean using a damp cloth and mild detergent, do not use bleach or abrasive cleaners.
- From time to time check that there are no loose screws on this unit.
- This product should not be discarded with household waste. Take to your local authority waste disposal centre.

Handy Hints

- Assemble all parts and bolts loosely during assembly, only once the product is complete should you fully tighten the bolts
- Regularly check and ensure That all bolts and fittings are tightened properly.

WARNING In order to help prevent overturning – please follow these instructions









To help prevent product toppling over please follow the below steps:-

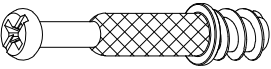
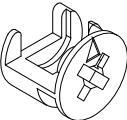
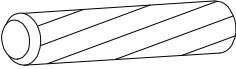
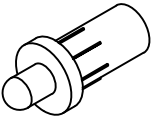
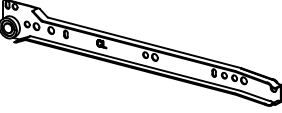
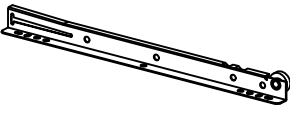
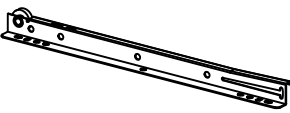
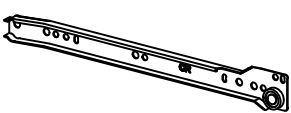



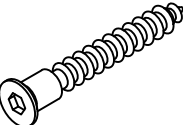
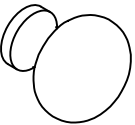
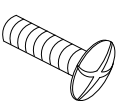
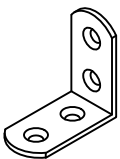
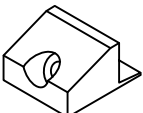

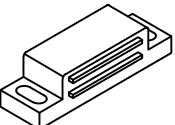
- Use the anti tip stap or wall fixing method provided (if applicable)
- Do not allow children to climb or hang on the furniture
- Do not open more than one drawer at a time
- Do not place heavy items in the top drawers
- Do not place heavy items on top of the furniture, unless the furniture has been designed for this purpose

Components - Fittings

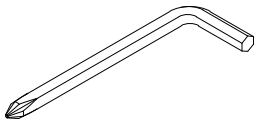
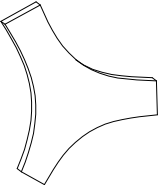
Please check you have all the panels listed below

Note: The quantities below are the correct amount to complete the assembly. In some cases, more fittings may be supplied than required.

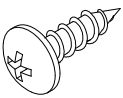
<p>A QTY: 15</p> 	<p>B QTY: 15</p> 	<p>C QTY: 40</p>  <p>Ø6*30mm</p>	<p>D QTY: 8</p> 
<p>CAM BOLT</p> <p>CL QTY: 2</p>  <p>L=300mm</p>	<p>CAM LOCK</p> <p>DL QTY: 2</p>  <p>L=300mm</p>	<p>WOOD DOWEL</p> <p>DR QTY: 2</p>  <p>L=300mm</p>	<p>DOOR PIN</p> <p>CR QTY: 2</p>  <p>L=300mm</p>
<p>ROLLER RUNNER</p> <p>E1 QTY: 2</p>  <p>L=600mm</p>	<p>ROLLER RUNNER</p> <p>E2 QTY: 2</p>  <p>L=600mm</p>	<p>ROLLER RUNNER</p> <p>F QTY: 44</p>  <p>Ø7*12mm</p>	<p>ROLLER RUNNER</p> <p>G QTY: 14</p>  <p>Ø6*12mm</p>
<p>BALL BEARING GLIDE</p> <p>H QTY: 30</p>  <p>Ø10*45mm</p>	<p>BALL BEARING GLIDE</p> <p>J QTY: 6</p> 	<p>FLAT HEAD SCREW</p> <p>K QTY: 6</p>  <p>Ø8*19mm</p>	<p>FLAT HEAD SCREW</p> <p>L QTY: 2</p> 
<p>ALLEN FLAT HEAD SCREW</p> <p>M QTY: 16</p> 	<p>HANDLE</p> <p>N QTY: 16</p>  <p>Ø6*19mm</p>	<p>BOLT</p> <p>O QTY: 4</p> 	<p>METAL BRACKET</p> <p>P QTY: 4</p> 
<p>CORNER BLOCK</p>	<p>STICKER</p>	<p>MAGNET</p>	<p>MAGNET PLATE</p>

<p>Q QTY: 1</p> 	<p>R QTY: 1</p> 	<p>S QTY: 10</p> 	<p>U QTY: 3</p> 
<p>ALLEN WRENCH</p>	<p>CAM TOOL</p>	<p>STICKER</p>	<p>CASTER</p>
<p>V QTY: 4</p> 	<p>W QTY: 28</p>  <p>Ø7*12mm</p>	<p>X QTY: 18</p>  <p>Ø8*38mm</p>	<p>Y QTY: 8</p>  <p>Ø8*45mm</p>
<p>LOCK CASTER</p>	<p>ROUND HEAD SCREW</p>	<p>FLAT HEAD SCREW</p>	<p>FLAT HEAD SCREW</p>

Using Camlocks

Step 1

Connect the male camlock as directed in the assembly instructions using a screwdriver.

1

DO NOT OVER TIGHTEN.
NE PAS SERRER EXCESSIVEMENT.

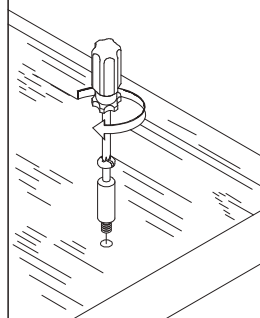

Step 2

Push the male camlock into the entry hole.

2

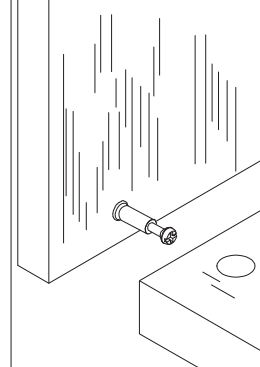

Step 3

Insert the female camlock as shown in the instruction.

Note: ensure that the arrow on the top of the camlock points towards the entry hole for the male camlock.

3

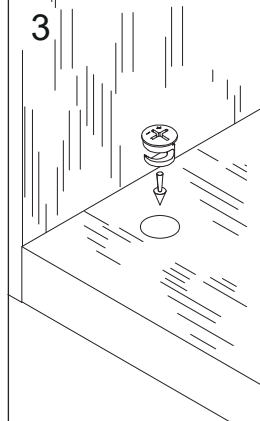

Step 4

Turn the female camlock clockwise with a screwdriver.

You should feel a click when the camlock is locked in place.

The joint is now secure.

4

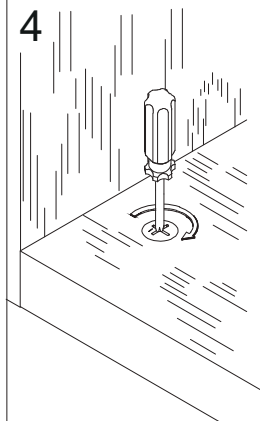

COMPONENTS - KEY DIAGRAM

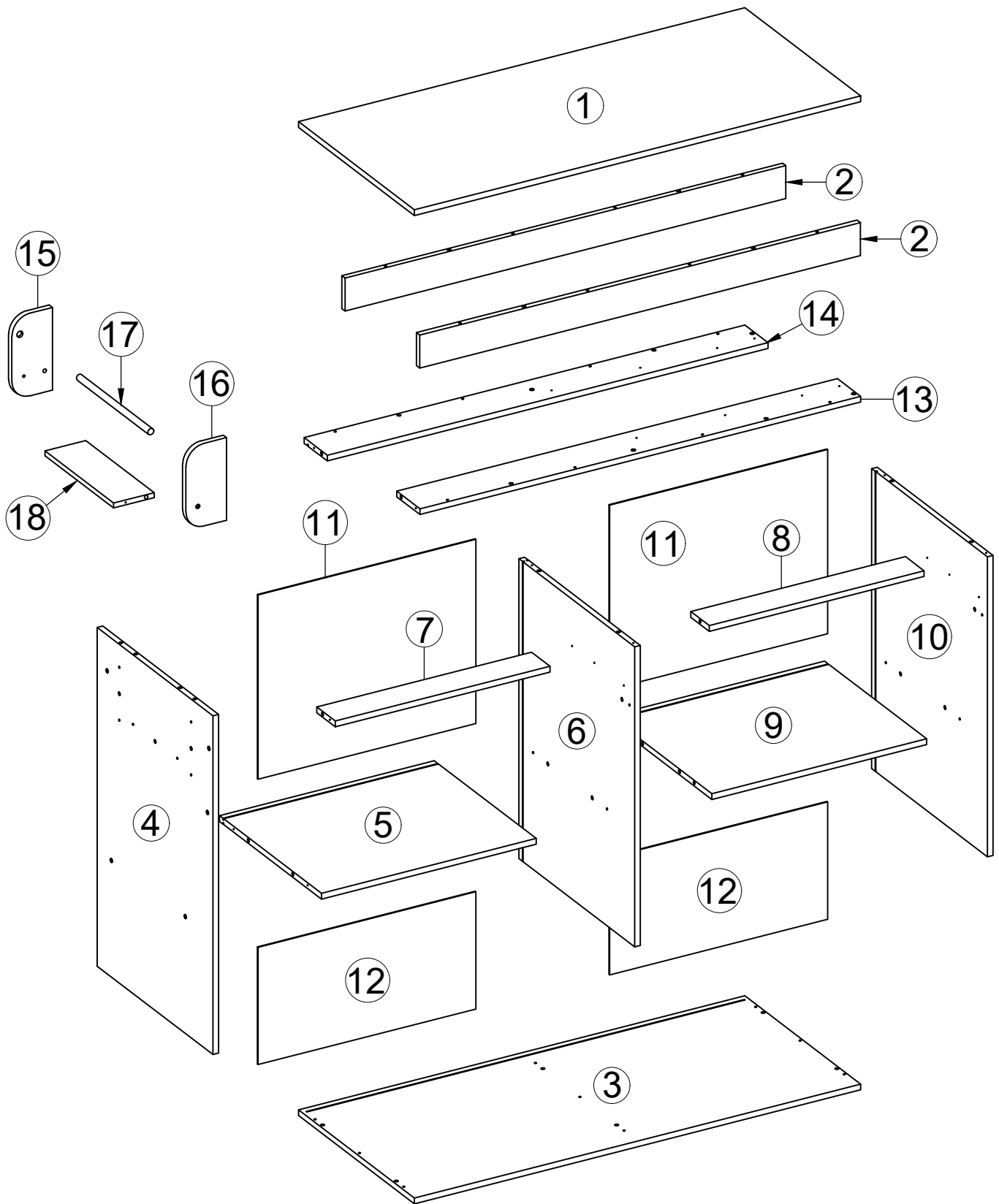

COMPONENTS - KEY DIAGRAM

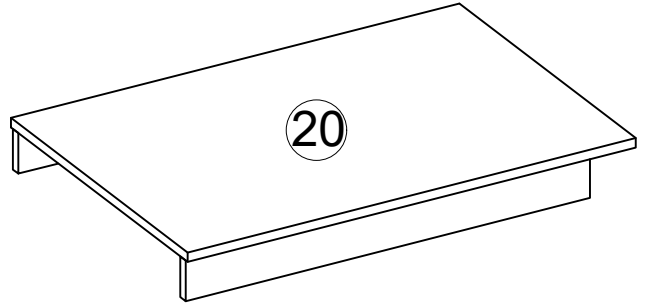
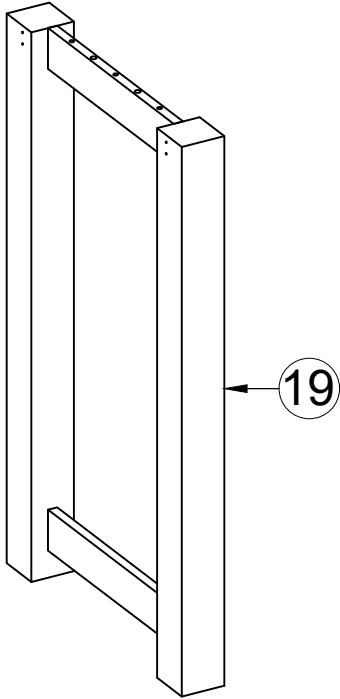

x2pcs

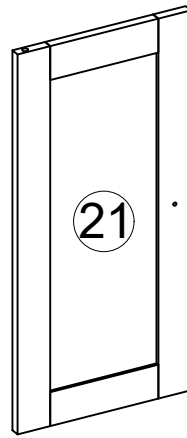

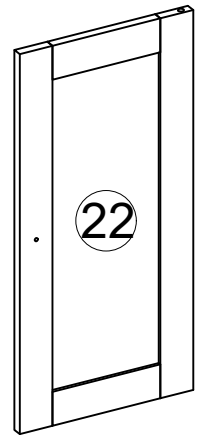

x2pcs



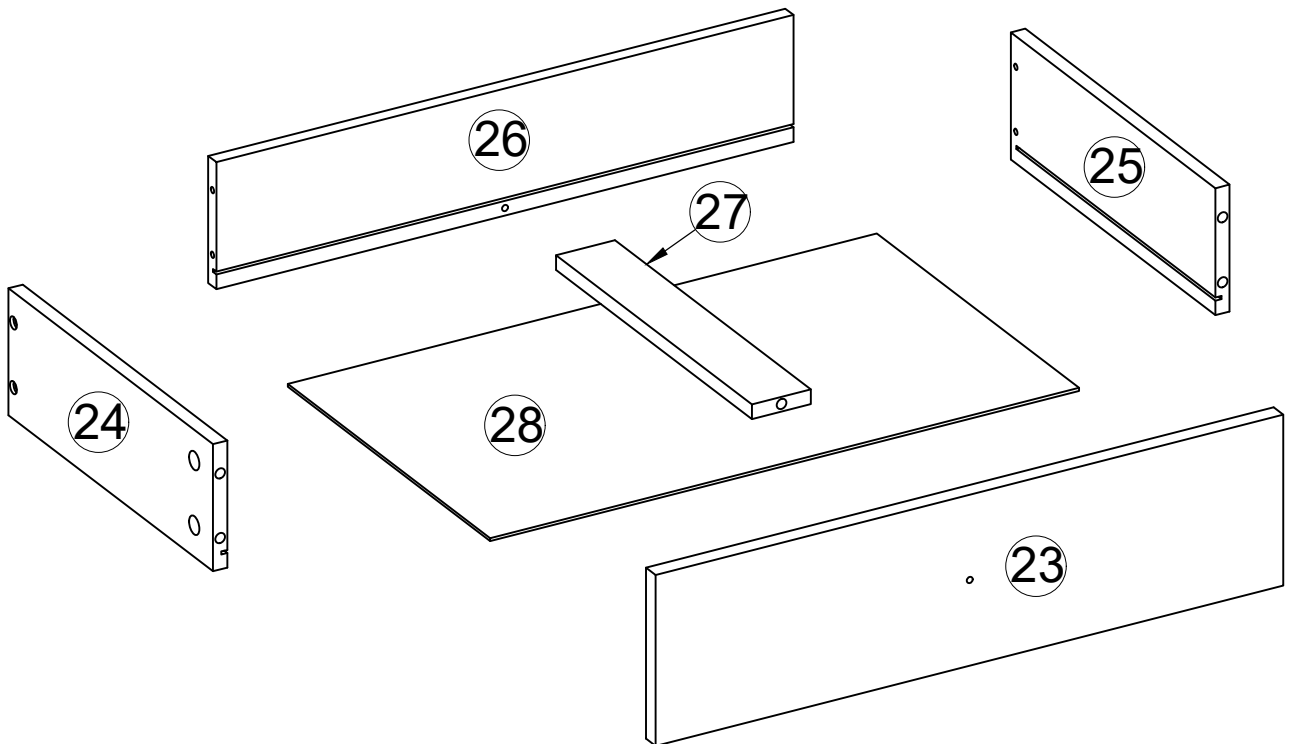

x2set

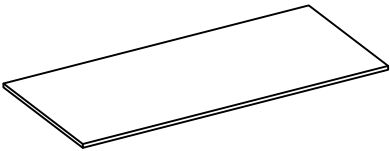

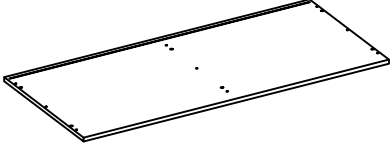
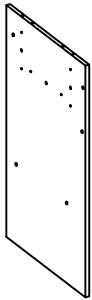
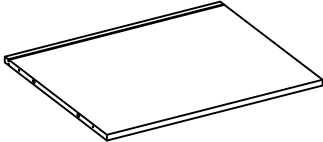
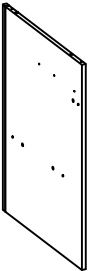
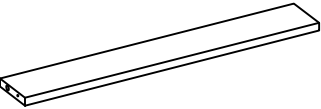
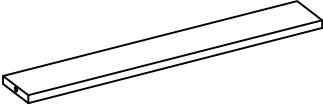
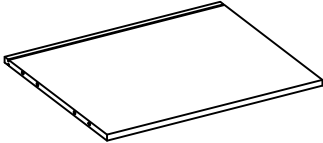
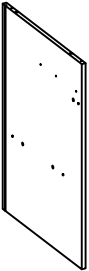
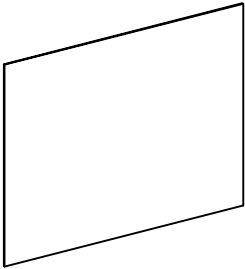
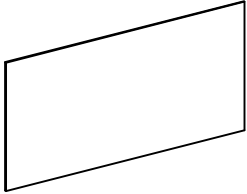
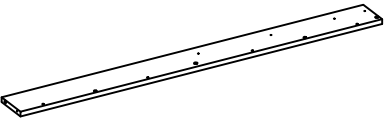
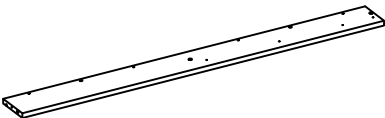
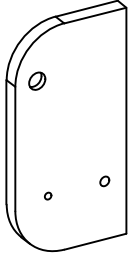
COMPONENTS - KEY DIAGRAM

<p>1</p> 	<p>2</p> 	<p>3</p> 
<p>TOP PANEL QTY: 1</p>	<p>SUPPORT TOP PANEL QTY: 2</p>	<p>BOTTOM PANEL QTY: 1</p>
<p>4</p> 	<p>5</p> 	<p>6</p> 
<p>LEFT PANEL QTY: 1</p>	<p>LEFT SHELF PANEL QTY: 1</p>	<p>PARTITION QTY: 1</p>
<p>7</p> 	<p>8</p> 	<p>9</p> 
<p>MIDDLE LEFT PANEL QTY: 1</p>	<p>MIDDLE RIGHT PANEL QTY: 1</p>	<p>RIGHT SHELF PANEL QTY: 1</p>
<p>10</p> 	<p>11</p> 	<p>12</p> 
<p>RIGHT PANEL QTY: 1</p>	<p>TOP BACK PANEL QTY: 2</p>	<p>BOTTOM BACK PANEL QTY: 2</p>
<p>13</p> 	<p>14</p> 	<p>15</p> 
<p>TOP FRONT RAIL QTY: 1</p>	<p>TOP BACK RAIL QTY: 1</p>	<p>BRACKET - LEFT QTY: 1</p>

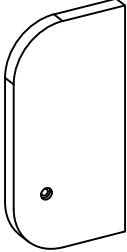
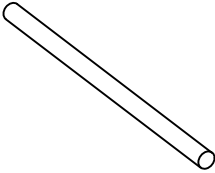
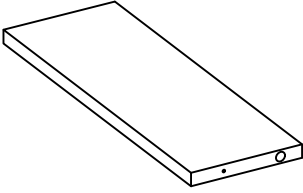
COMPONENTS - KEY DIAGRAM

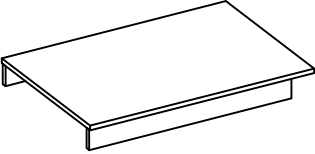
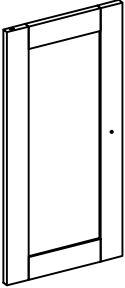
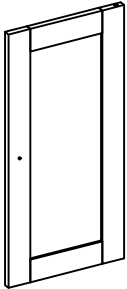
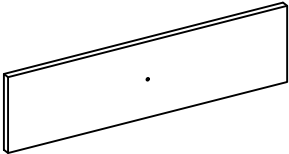
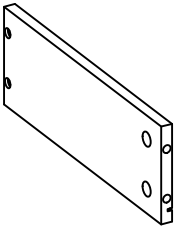
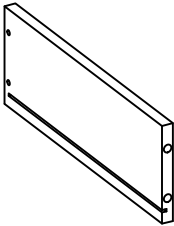
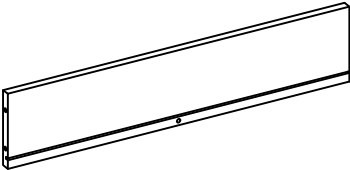
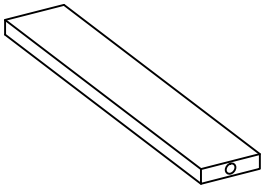
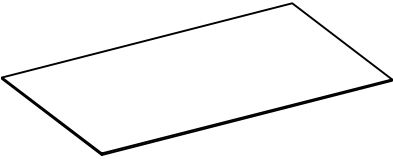
<p>16</p> 	<p>17</p> 	<p>18</p> 
<p>BRACKET - RIGHT QTY: 1</p>	<p>BRACKET PULL BAR QTY: 1</p>	<p>BRACKET - BOTTOM QTY: 1</p>
<p>19</p> 	<p>20</p> 	<p>21</p> 
<p>LEG (Extension Work Top) QTY: 1</p>	<p>EXTENSION WORK TOP QTY: 1</p>	<p>LEFT DOOR QTY: 2</p>
<p>22</p> 	<p>23</p> 	<p>24</p> 
<p>RIGHT DOOR QTY: 2</p>	<p>DRAWER FRONT QTY: 2</p>	<p>DRAWER SIDE - LEFT QTY: 2</p>
<p>25</p> 	<p>26</p> 	<p>27</p> 
<p>DRAWER SIDE - RIGHT QTY: 2</p>	<p>DRAWER BACK QTY: 2</p>	<p>SUPPORT BOTTOM DRAWER QTY: 2</p>
<p>28</p> 		
<p>DRAWER BOTTOM QTY: 2</p>		

**Slides Must Be Separated Before Assembly.
After Separated, Set Aside Until Needed for Assembly.**

Las diapositivas deben separarse antes del montaje.
Después de la separación, déjelo a un lado hasta que sea necesario.

Les glissières doivent être séparées avant l'assemblage.
Après la séparation, mettez de côté jusqu'au moment de l'assemblage.

**Pay attention when connecting !
The sliding module must be at the front end.**

**STEP 1 : Extend Slide
Extender la diapositiva**

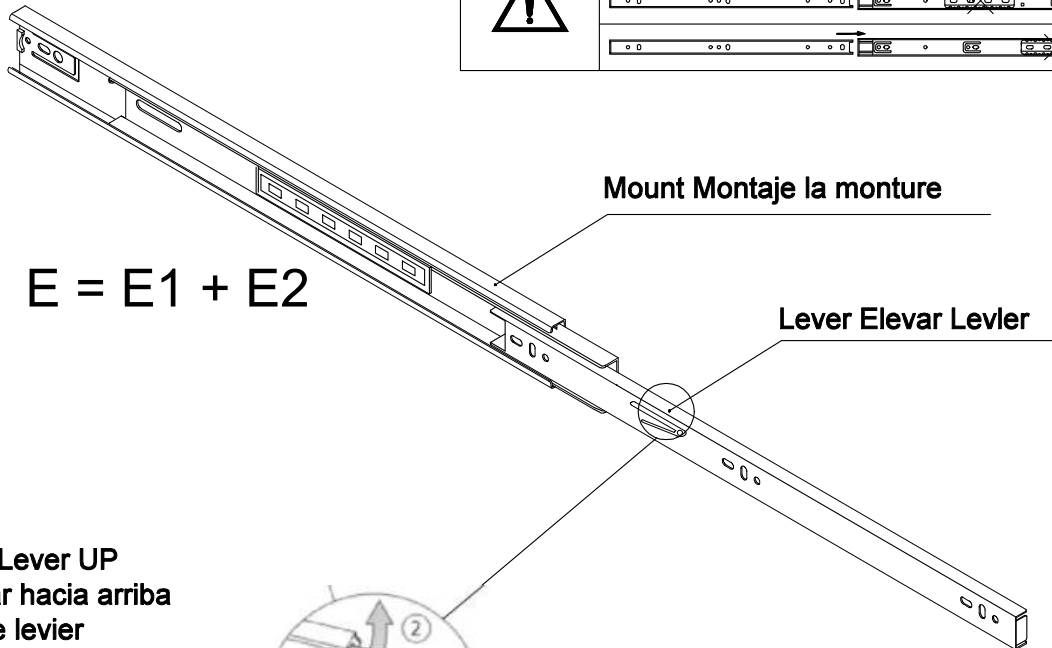
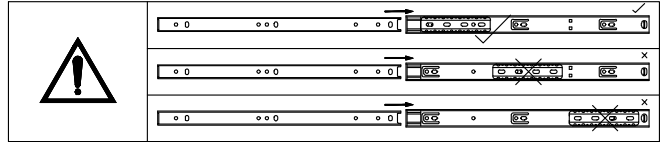

**STEP 2: Push Lever UP
Empujar hacia arriba
Lever le levier**



**Push lever for the left of drawer ,
press the lever for the right of drawer.**

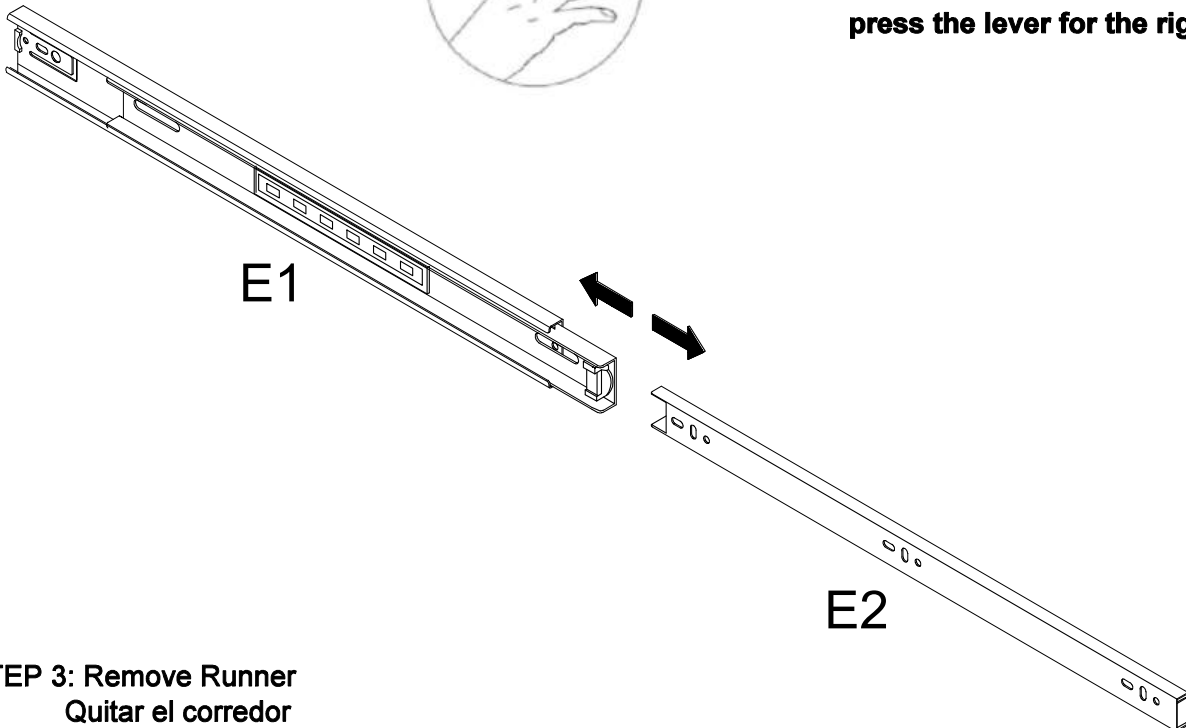



**STEP 3: Remove Runner
Quitar el corredor
Enever le coureur**

ASSEMBLY INSTRUCTIONS

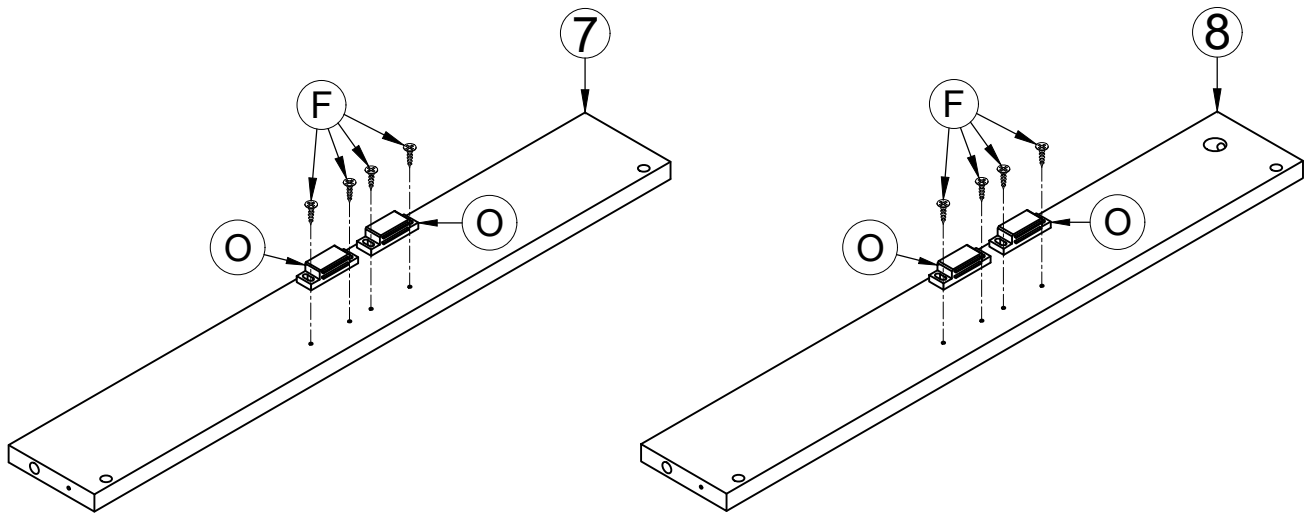



STEP 1

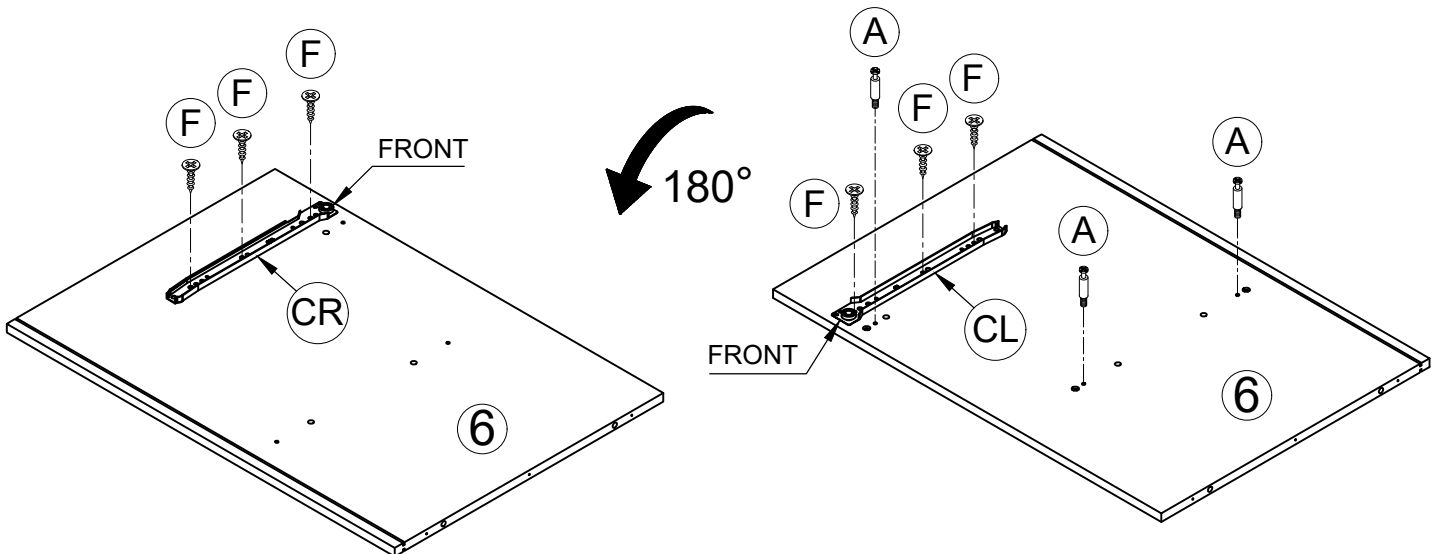
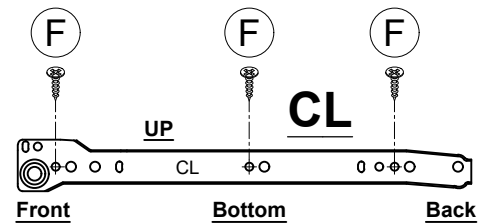
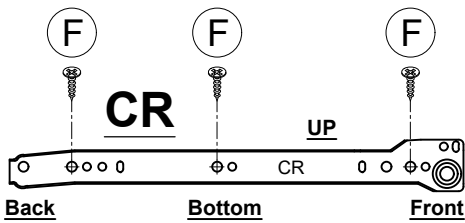

F		8PCS
O		4PCS

STEP 2



CL		1PC	A		3PCS
CR		1PC	F		6PCS

ASSEMBLY INSTRUCTIONS

STEP 3

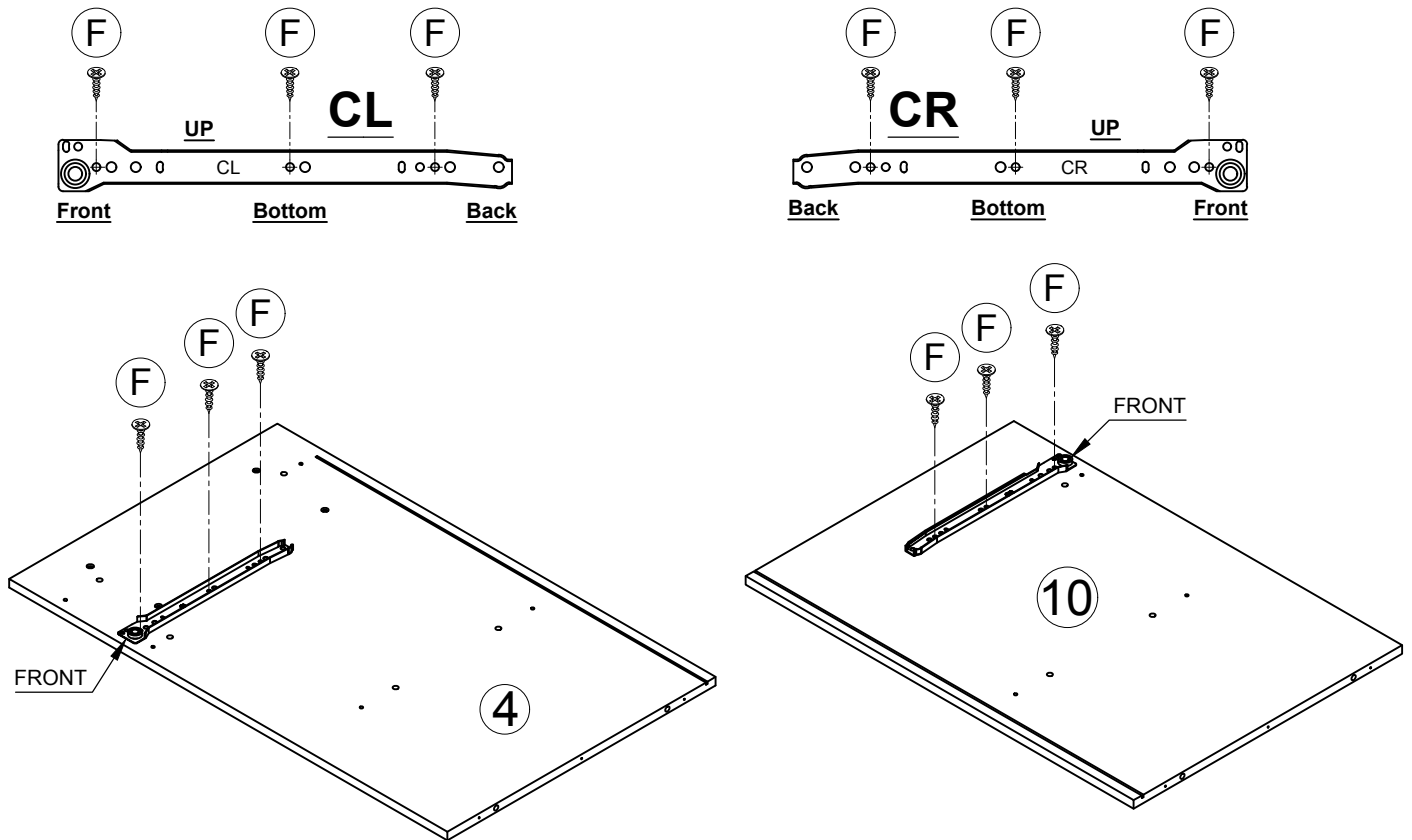

CL		1PC			
CR		1PC	F		6PCS

STEP 4

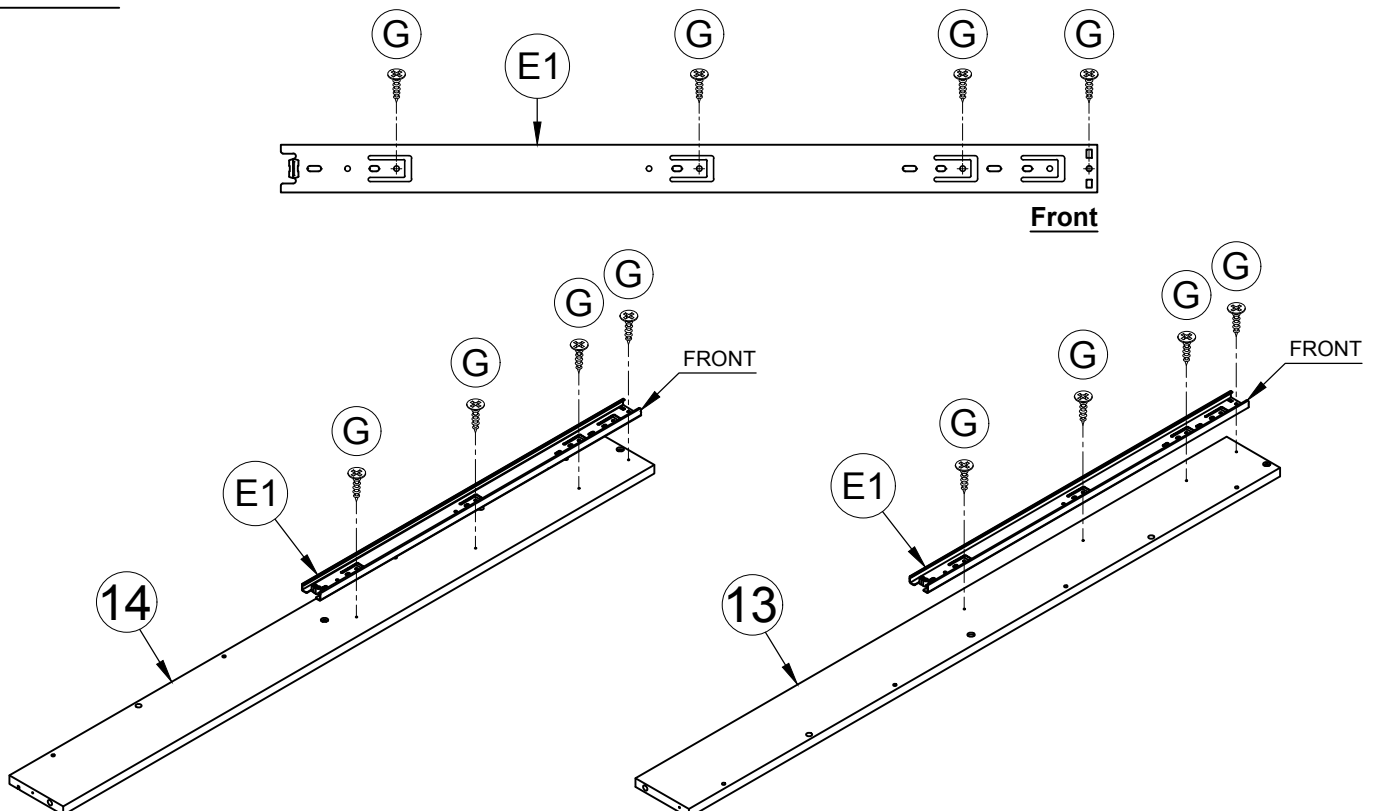



E1		2PCS	G		8PCS
----	--	------	---	--	------

ASSEMBLY INSTRUCTIONS

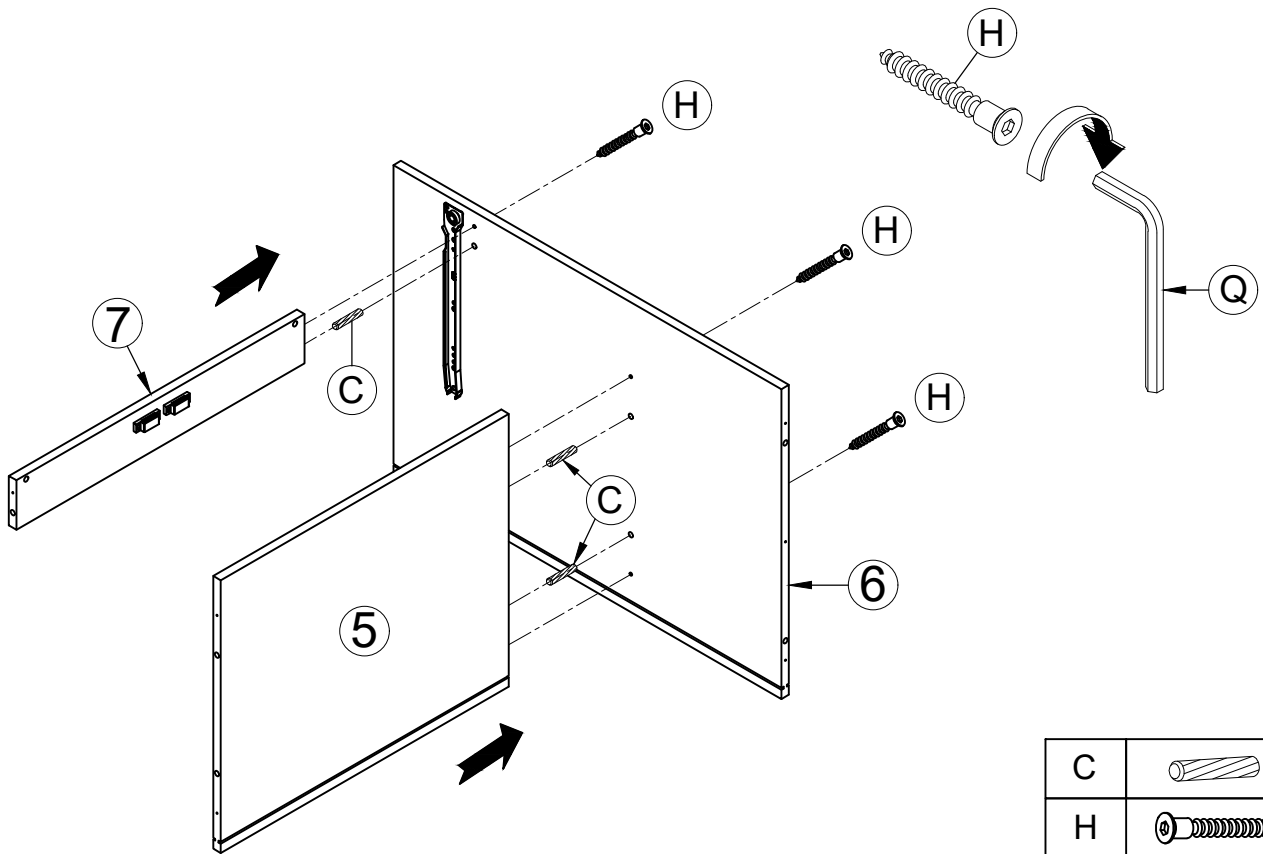

STEP 5

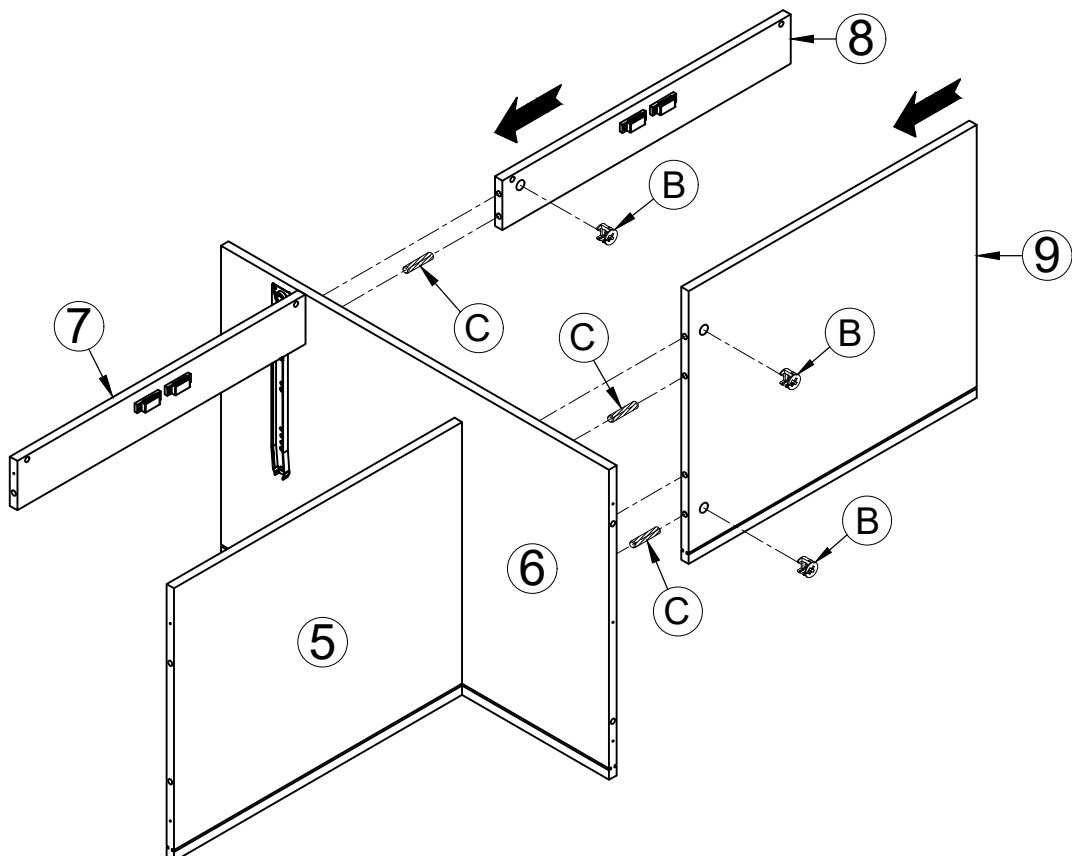

C		3PCS
H		3PCS
Q		1PC

STEP 6



B		3PCS	C		3PCS
---	---	------	---	---	------

ASSEMBLY INSTRUCTIONS

STEP 7

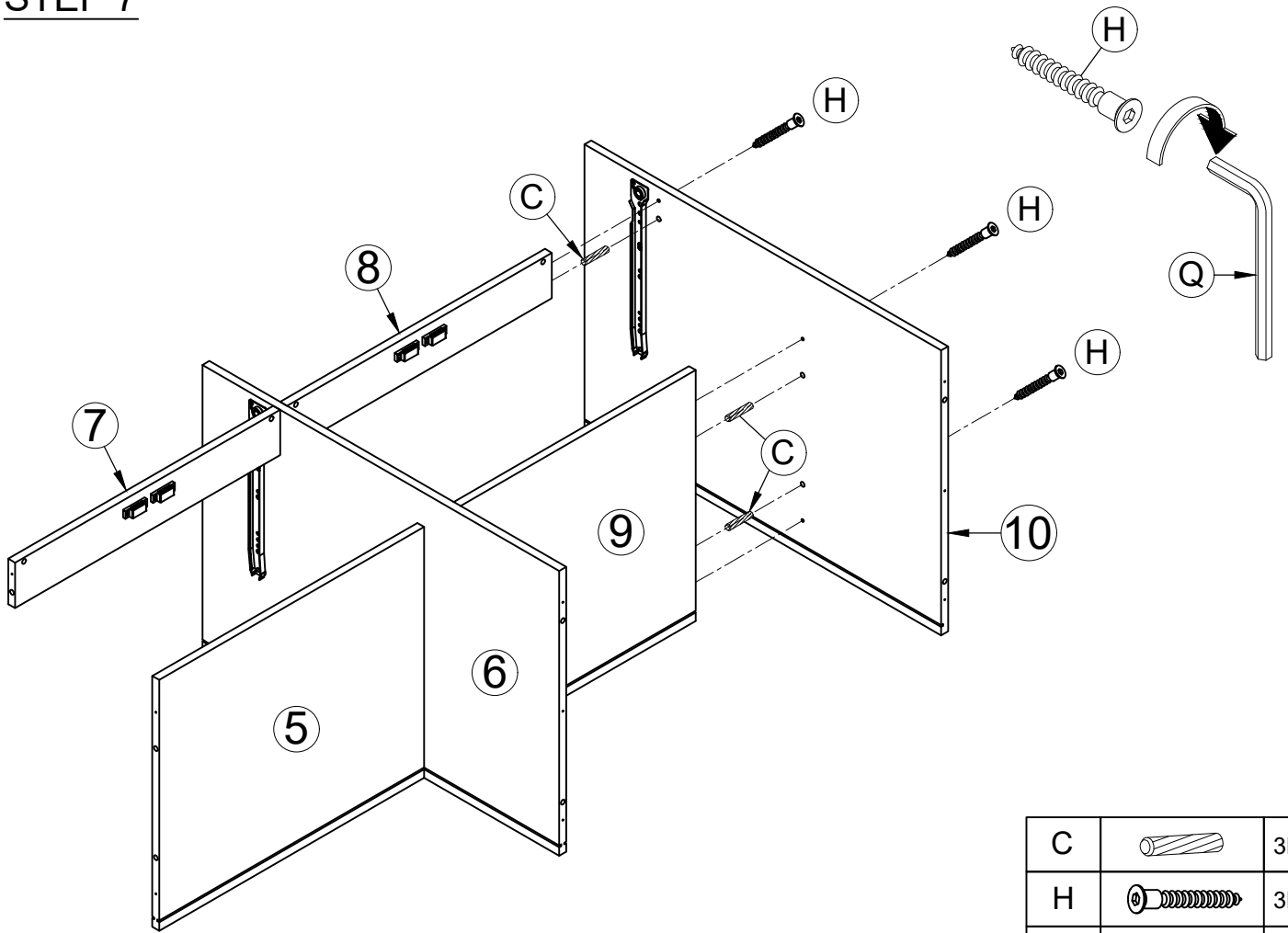



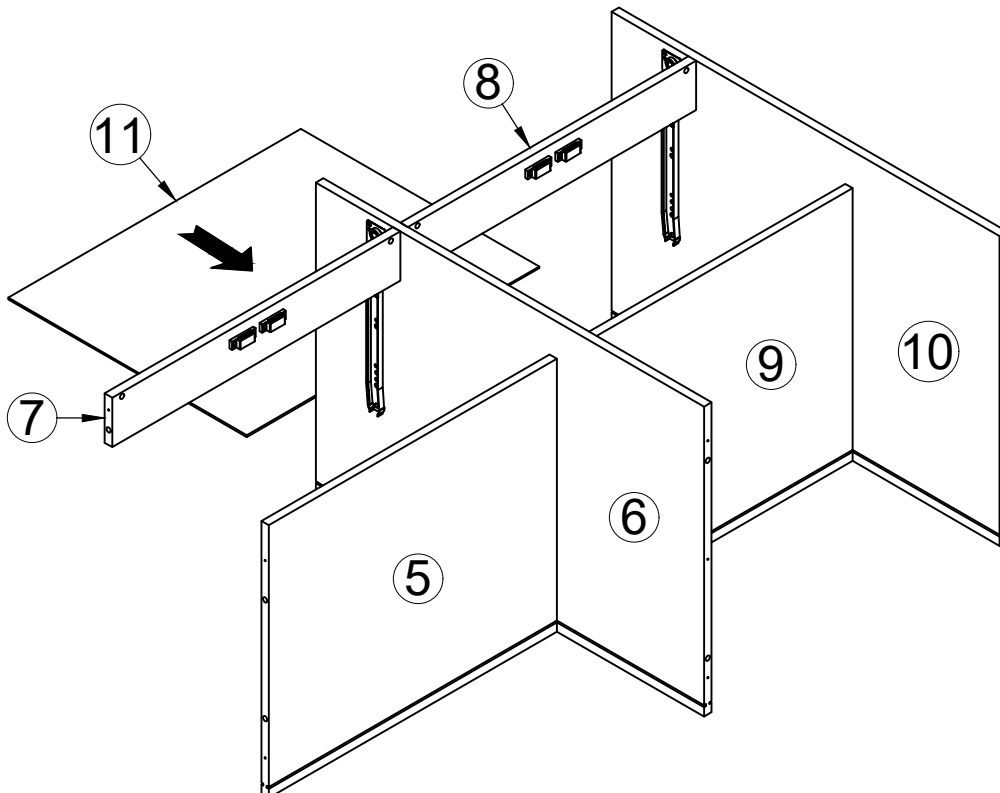

STEP 8

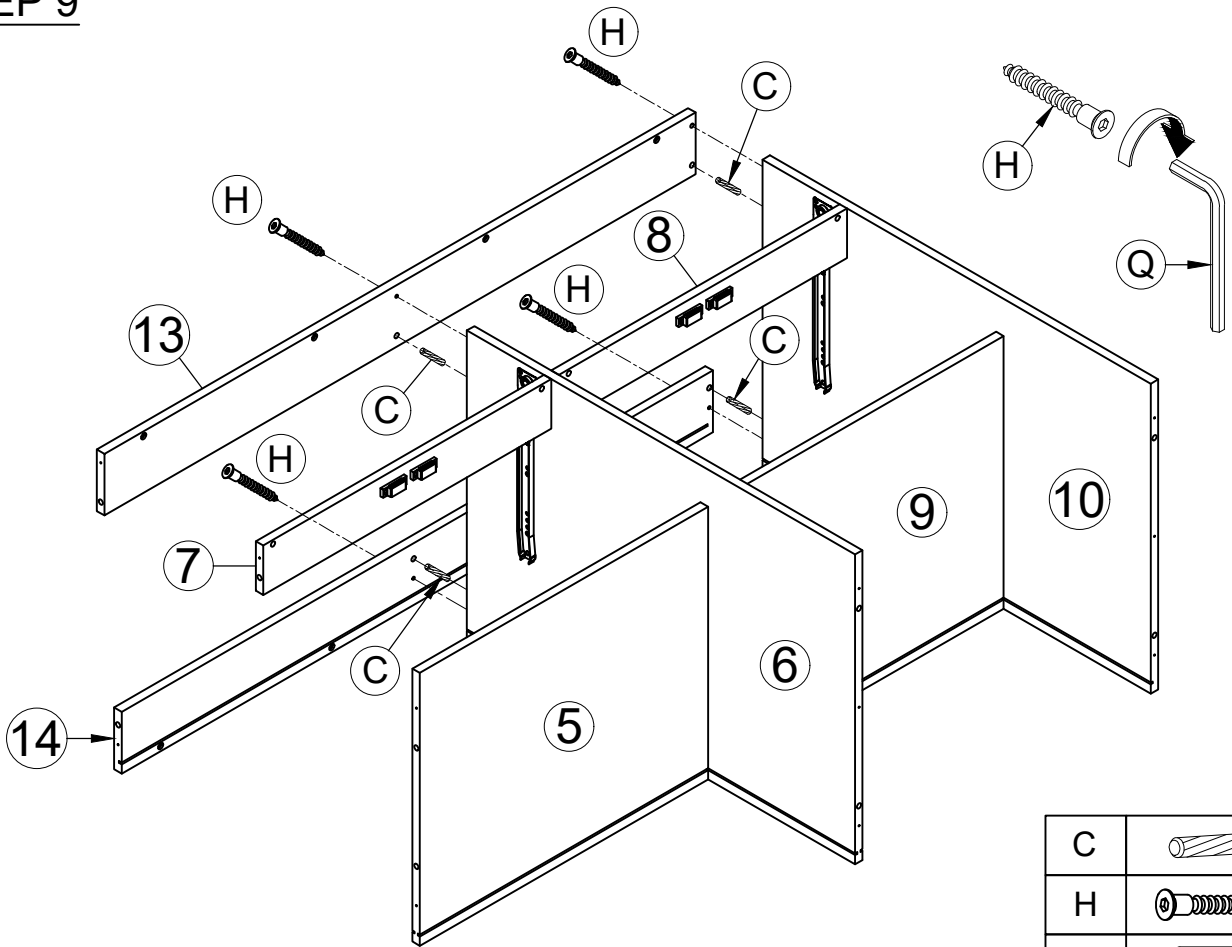

ASSEMBLY INSTRUCTIONS

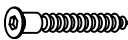

STEP 9

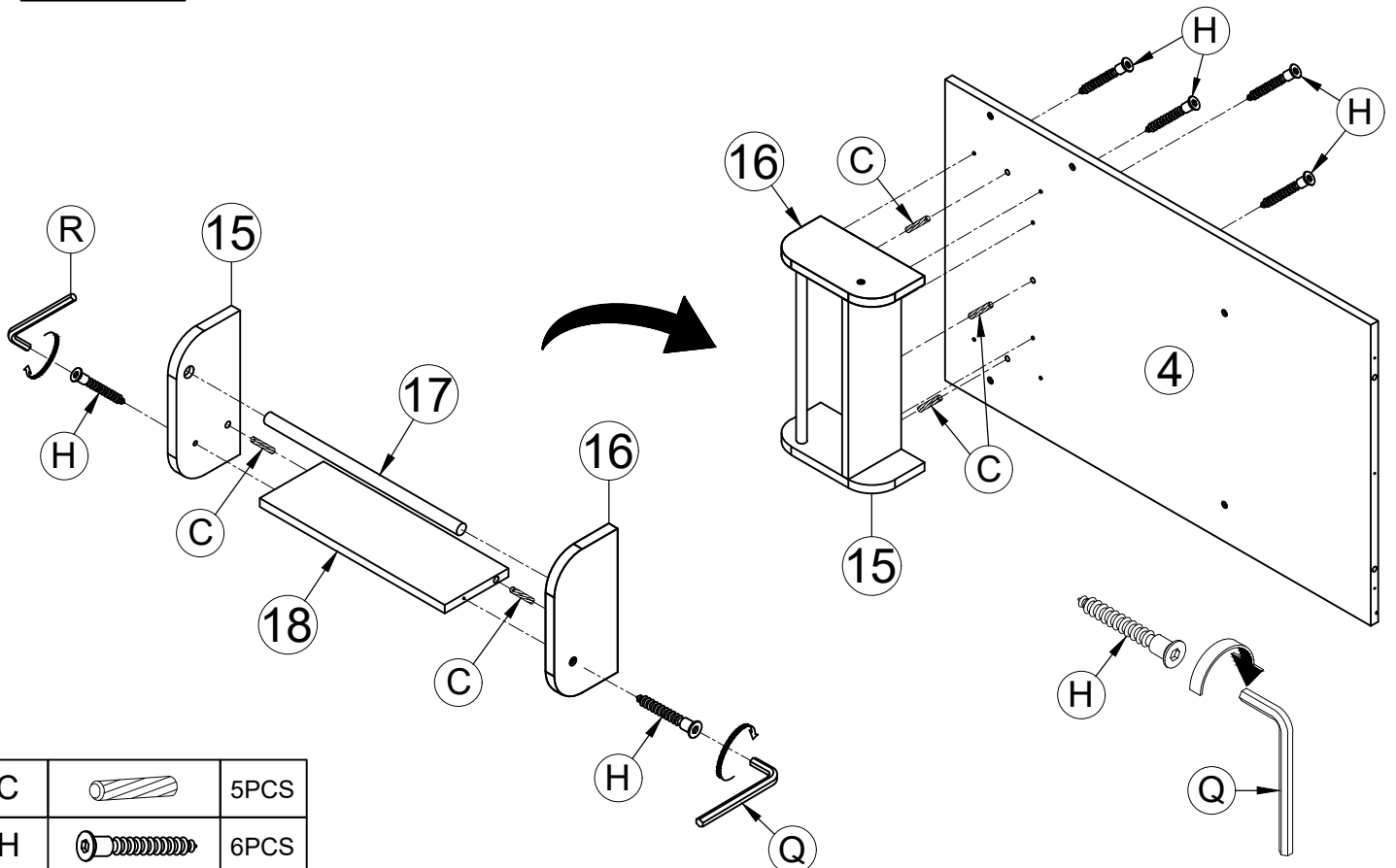

C		4PCS
H		4PCS
Q		1PC

STEP 10



C		5PCS
H		6PCS
Q		1PC

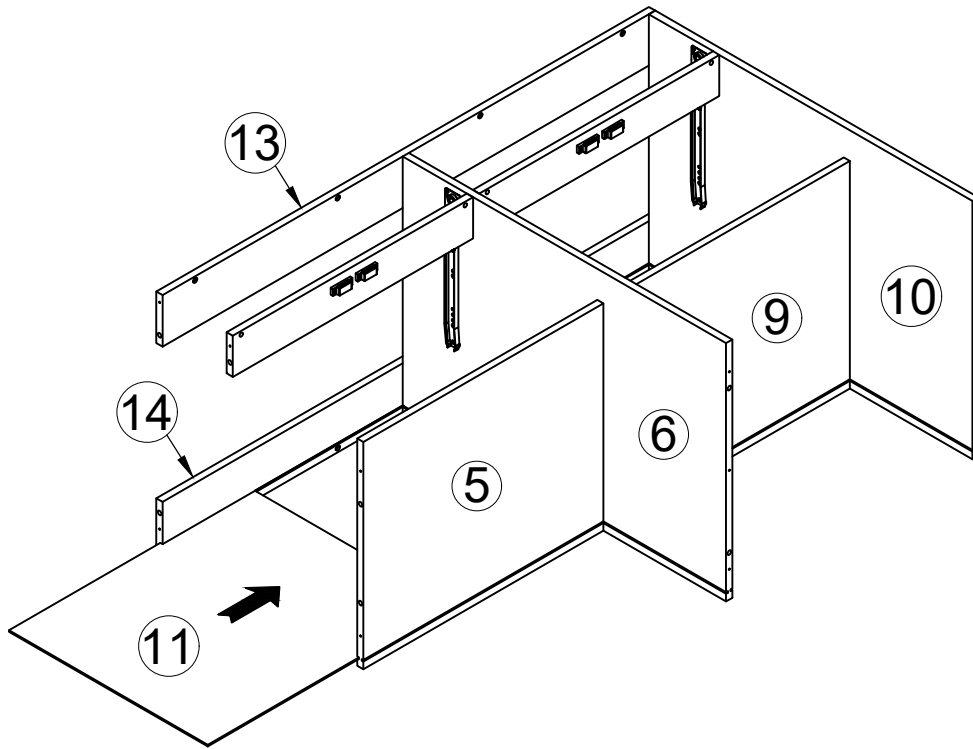

ASSEMBLY INSTRUCTIONS

STEP 11

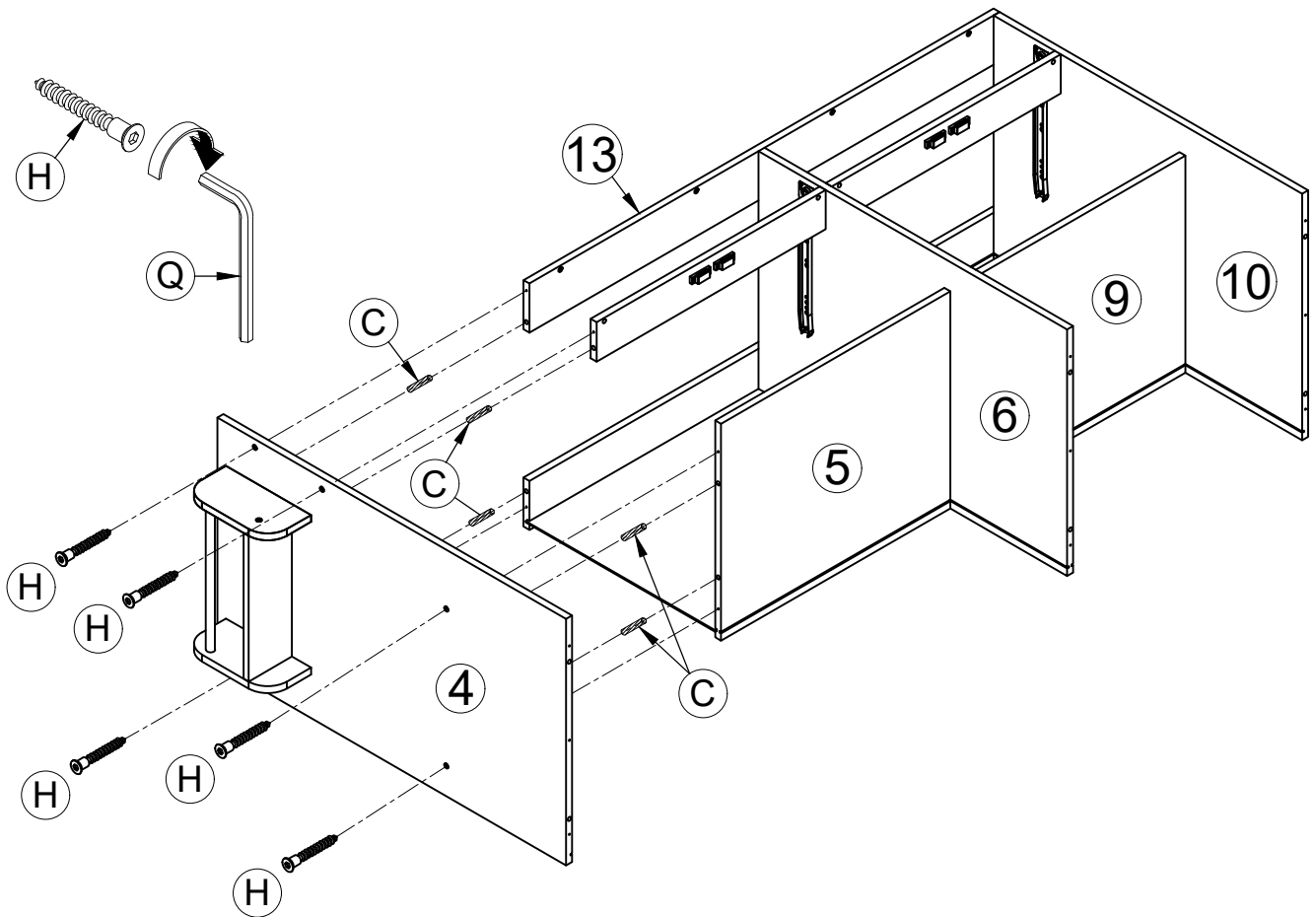

STEP 12



C		5PCS	H		5PCS	Q		1PC
---	---	------	---	---	------	---	---	-----

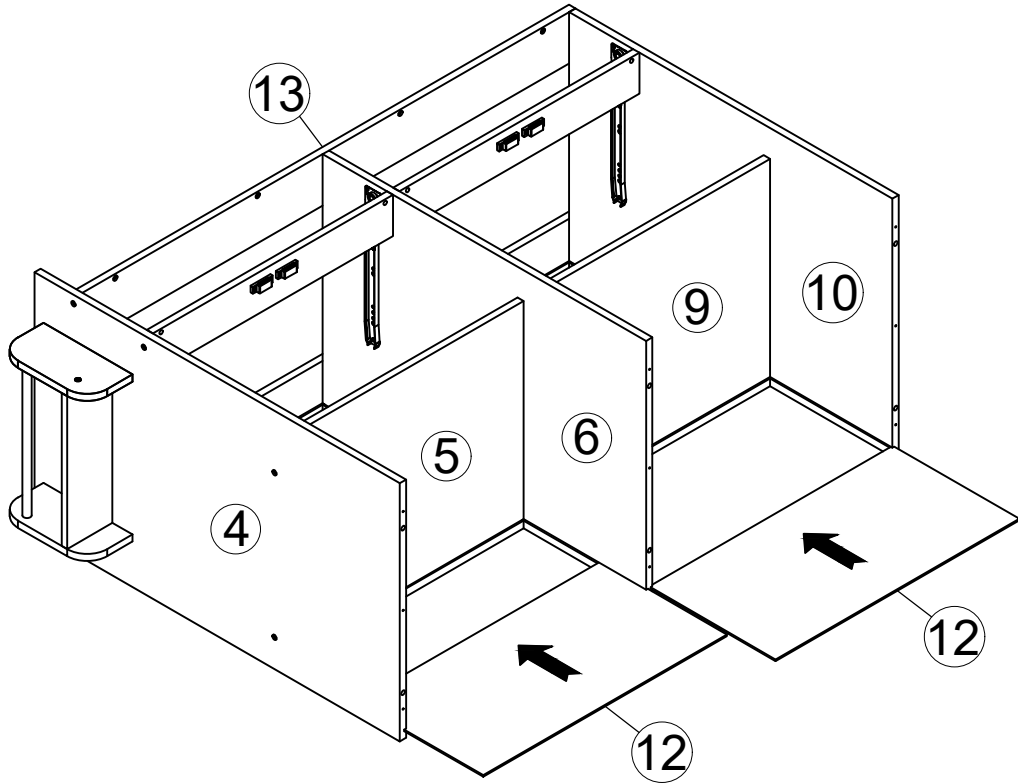

ASSEMBLY INSTRUCTIONS

STEP 13

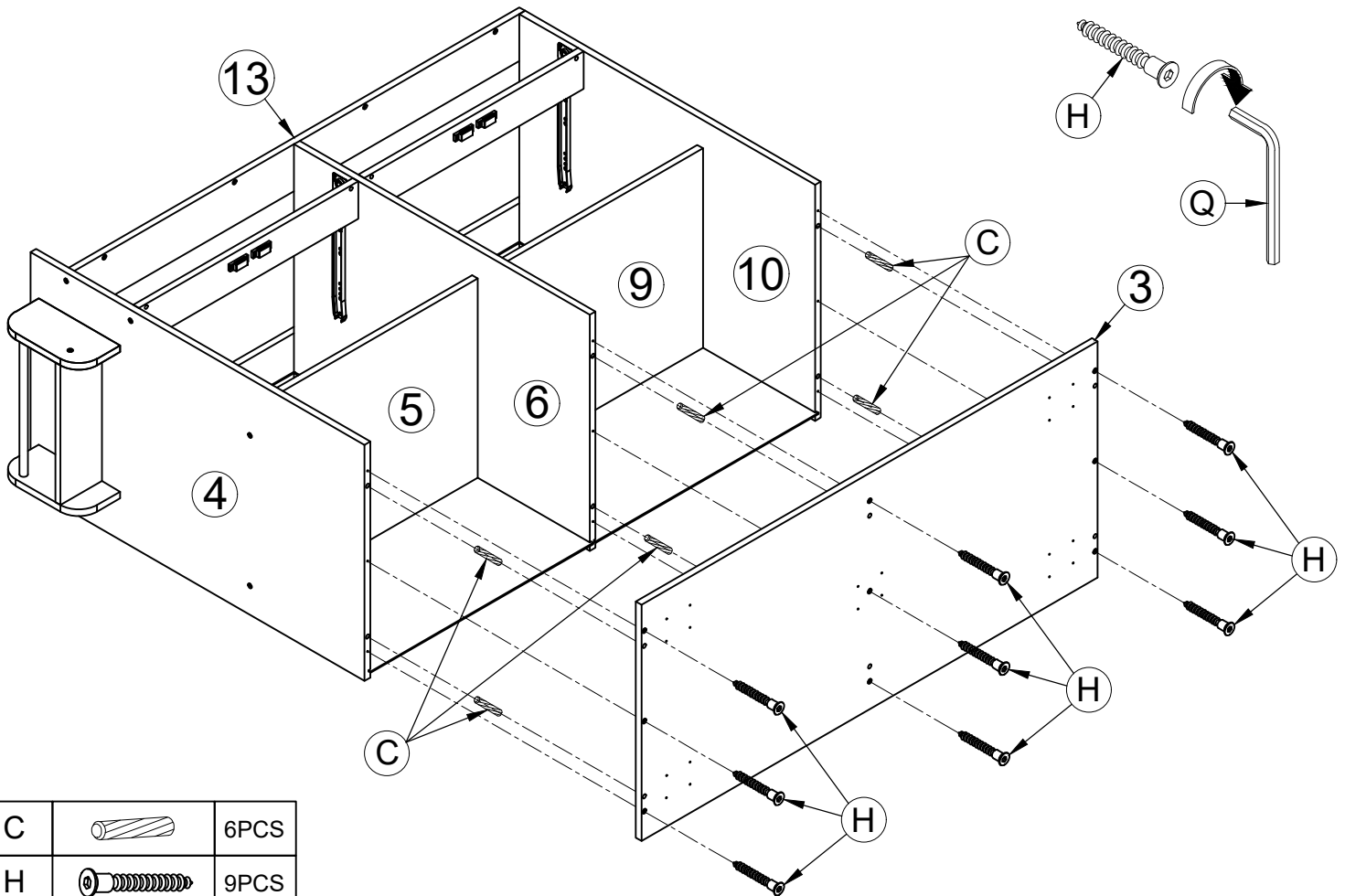

STEP 14

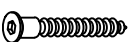



C		6PCS
H		9PCS
Q		1PC

ASSEMBLY INSTRUCTIONS

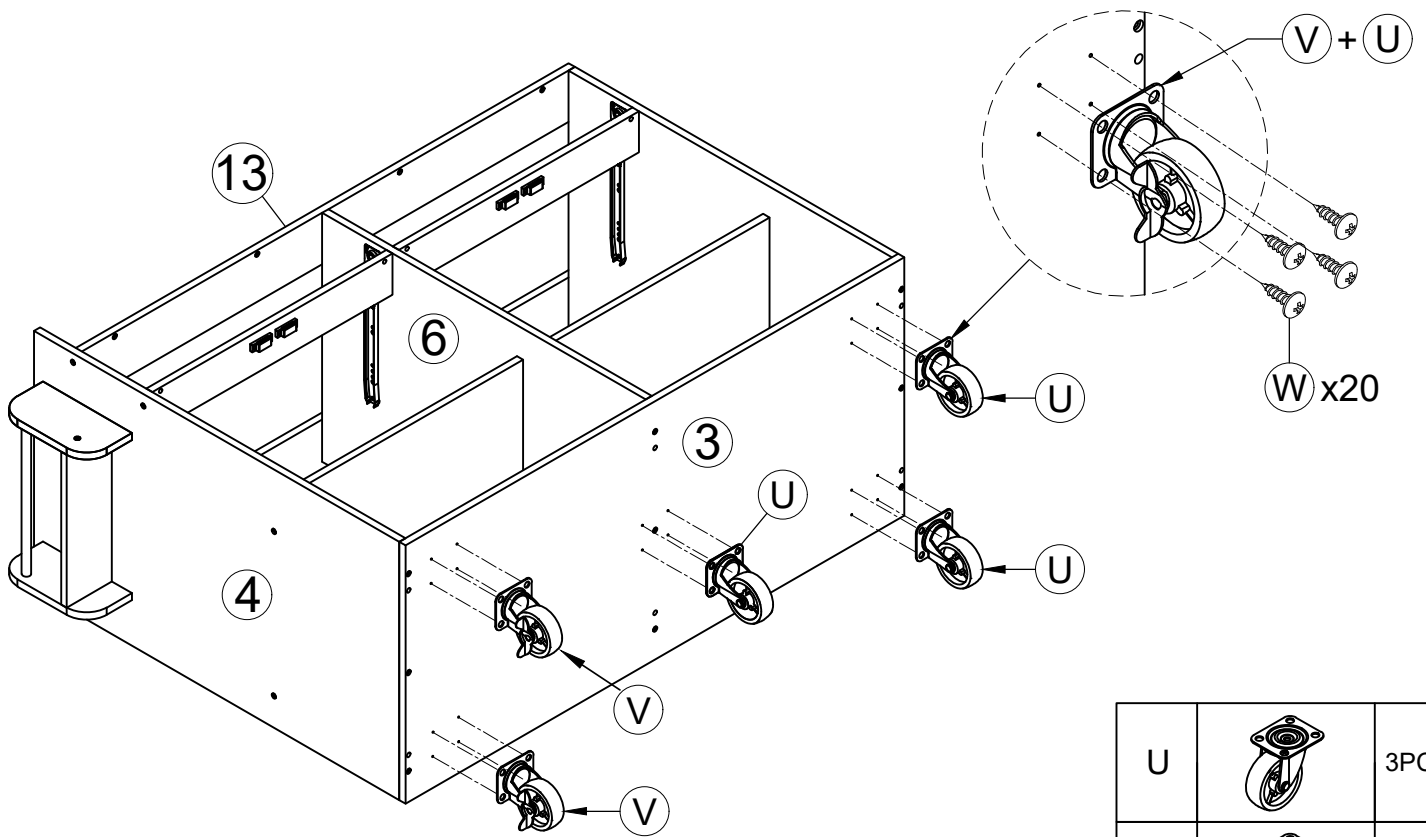

STEP 15

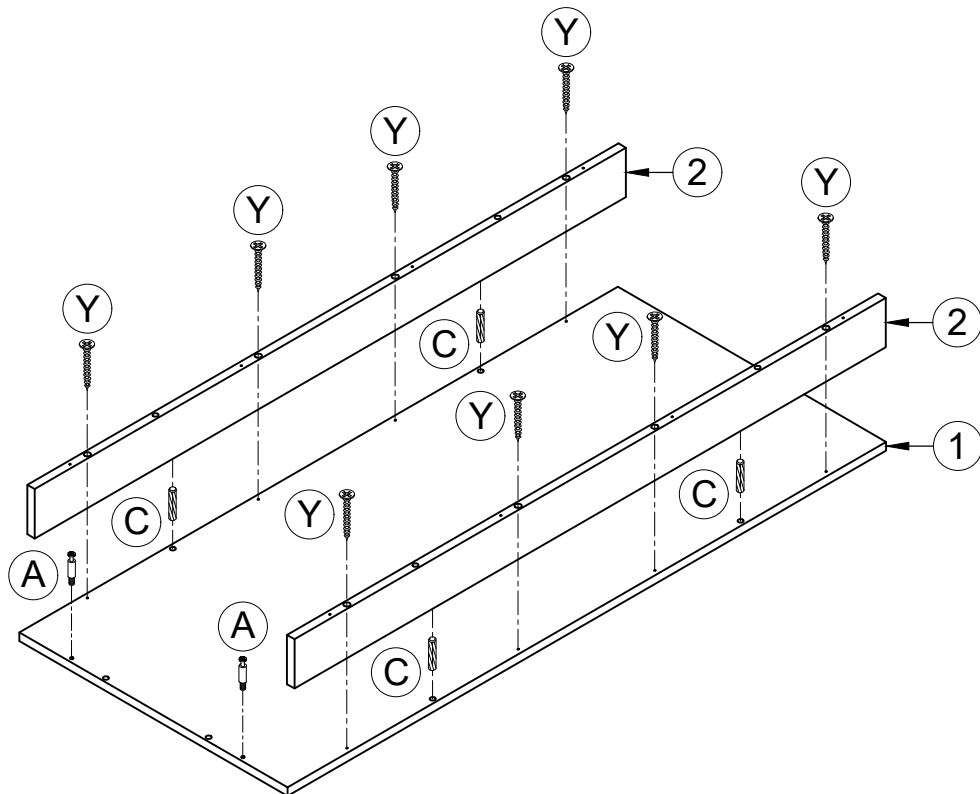

U		3PCS
V		2PCS
W		20PCS

STEP 16





A		2PCS	C		4PCS	Y		8PCS
---	---	------	---	---	------	---	---	------

ASSEMBLY INSTRUCTIONS

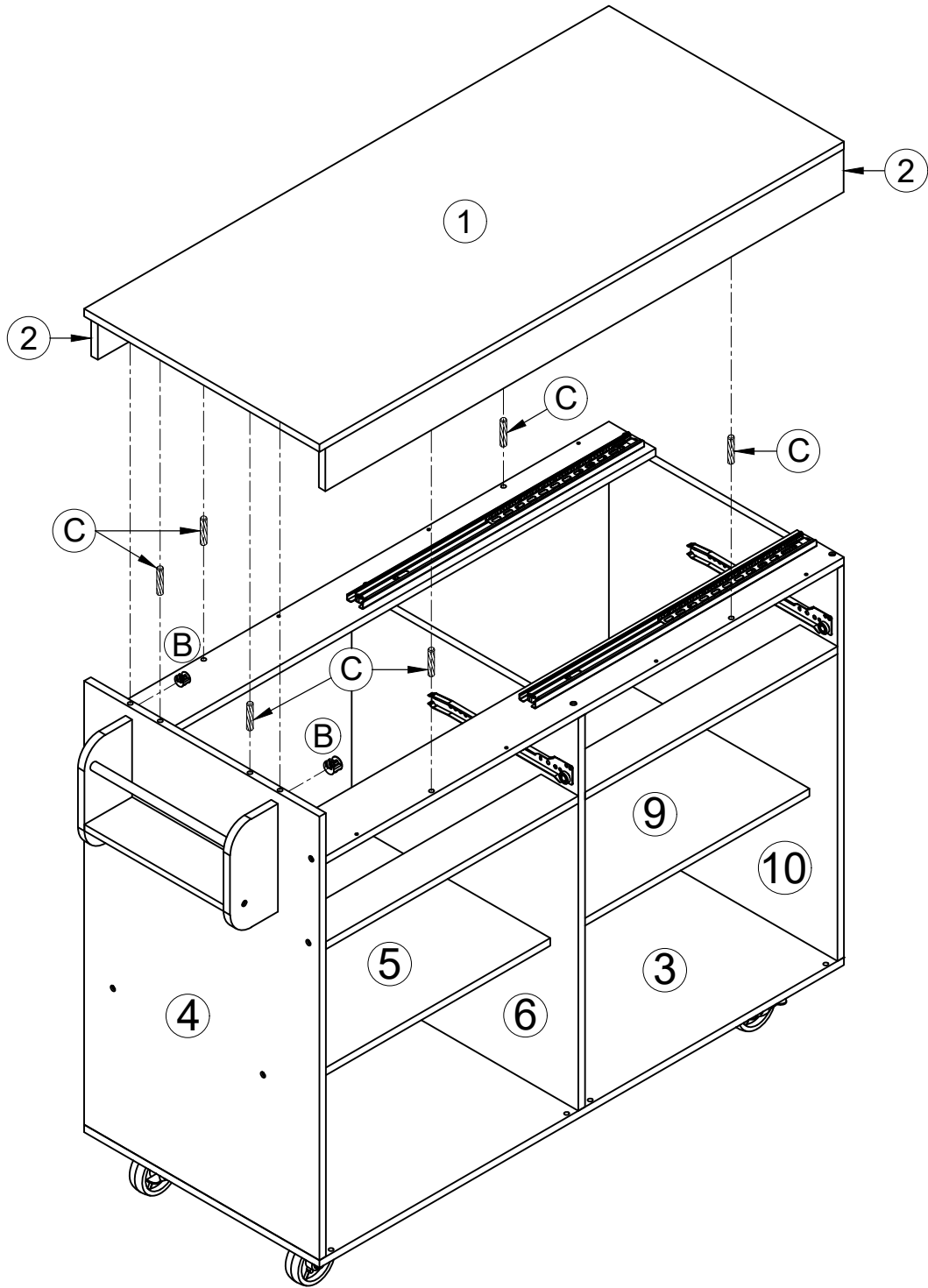
STEP 17



B		2PCS
C		6PCS

ASSEMBLY INSTRUCTIONS

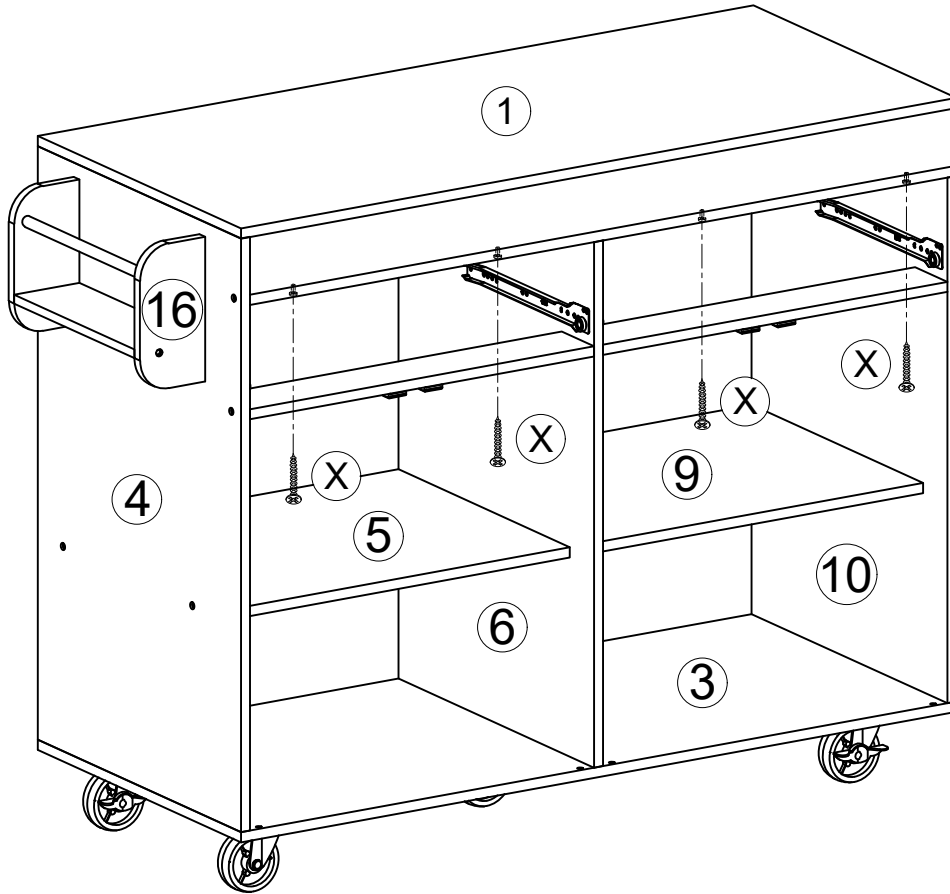

STEP 18

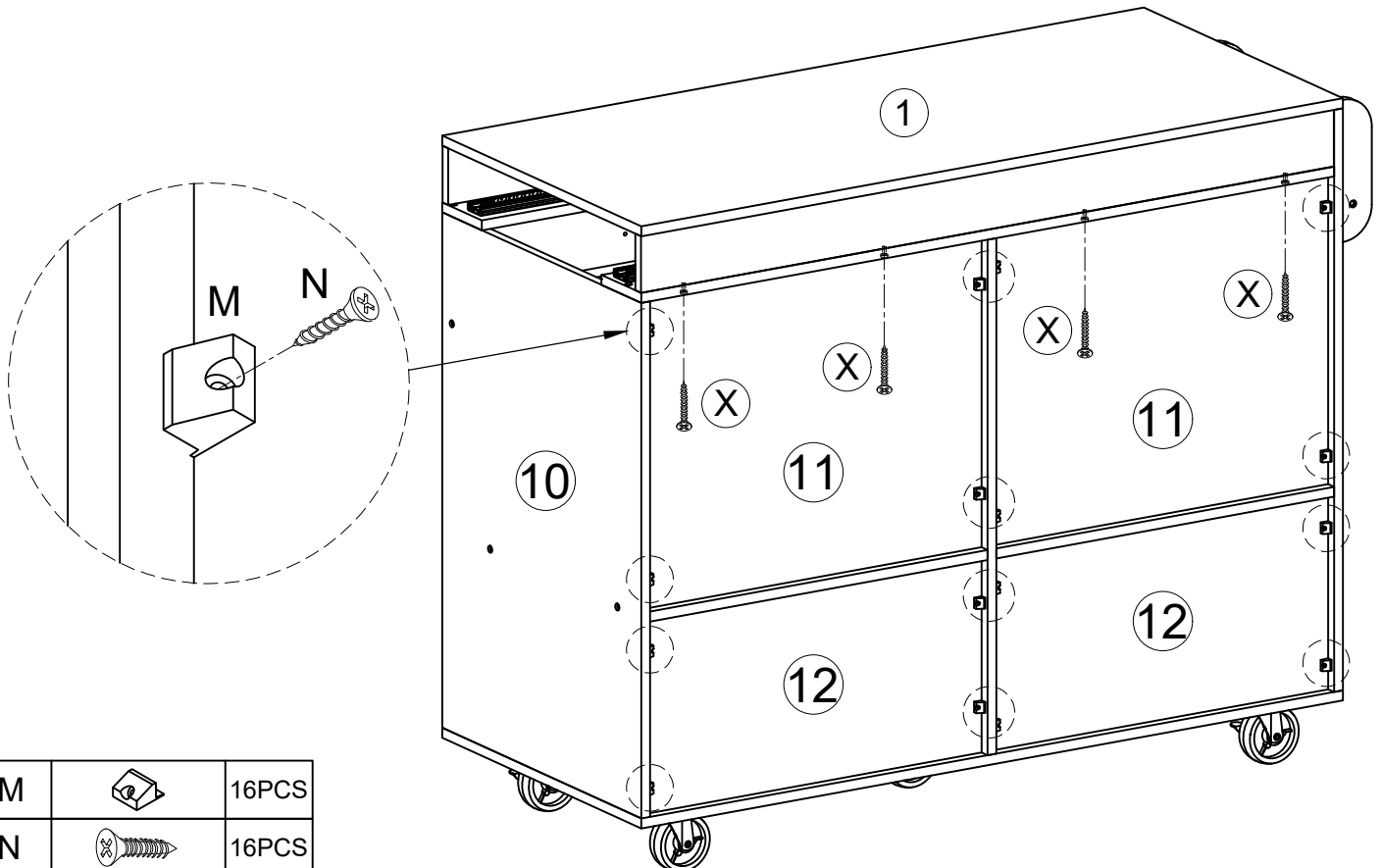

X		4PCS
---	---	------

STEP 19



M		16PCS
N		16PCS
X		4PCS

ASSEMBLY INSTRUCTIONS

STEP 20 x2 Set

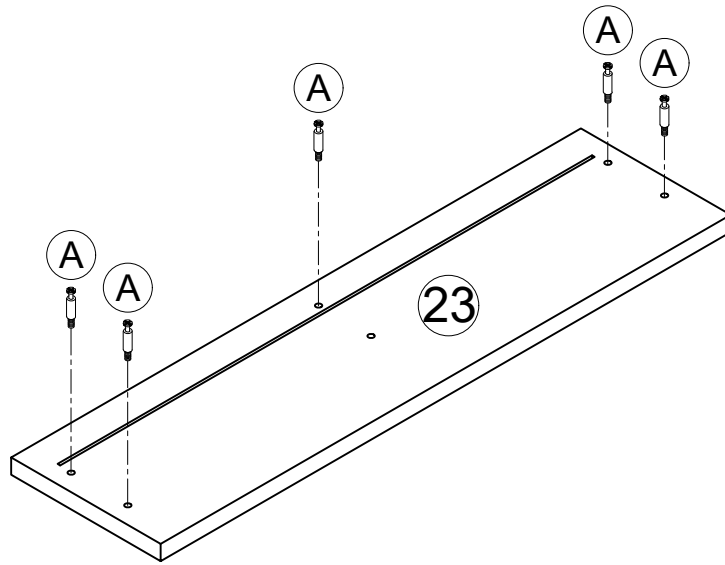

A		10PCS
---	---	-------

STEP 21 x2 Set

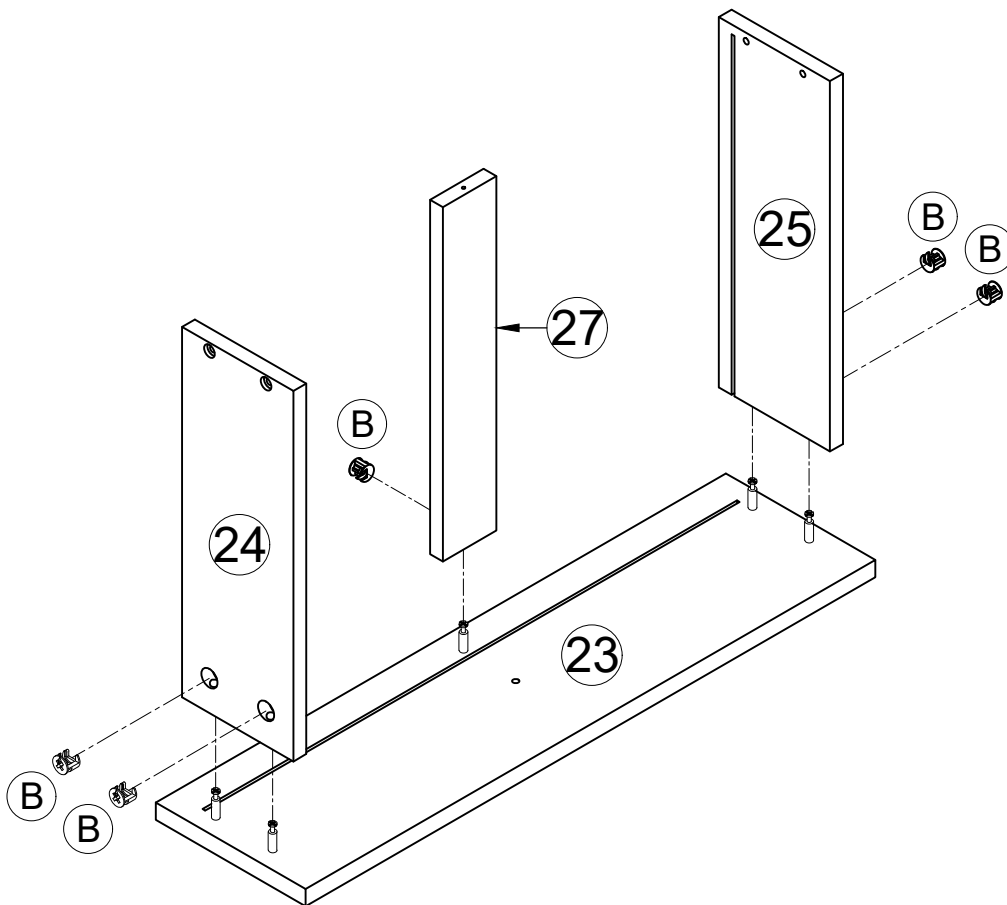

B		10PCS
---	---	-------

ASSEMBLY INSTRUCTIONS

STEP 22 x2 Set

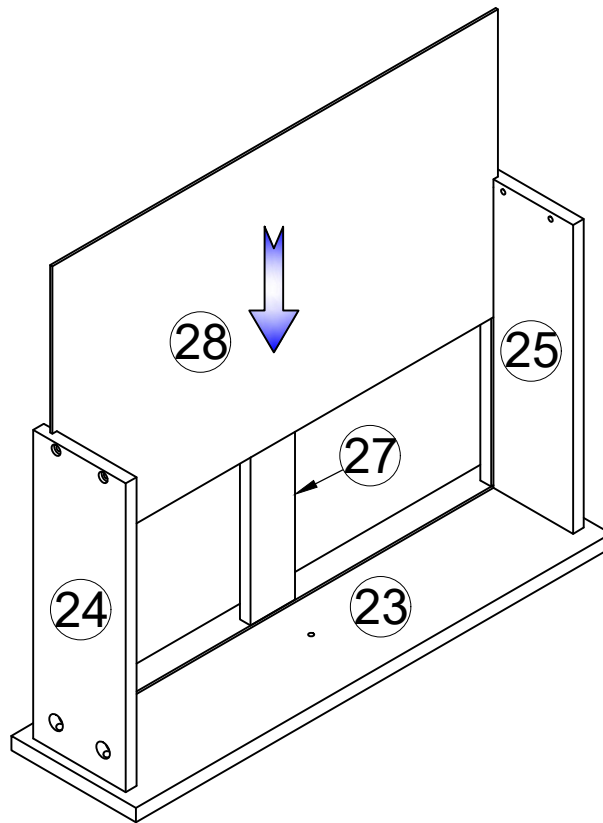

STEP 23 x2 Set

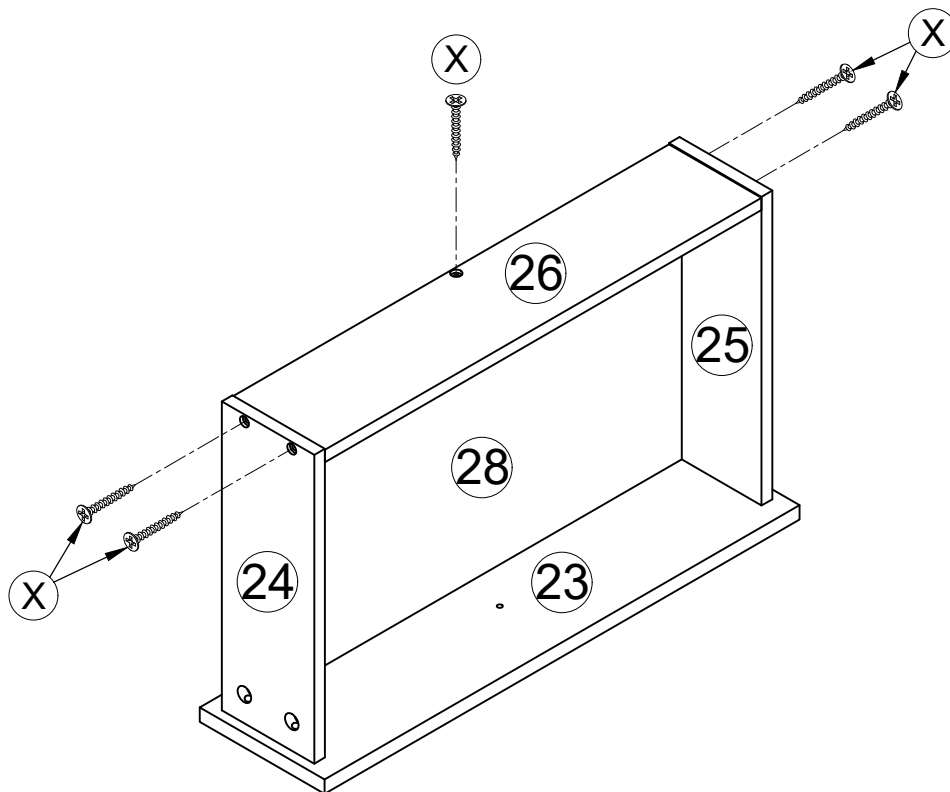

X





10PCS

ASSEMBLY INSTRUCTIONS

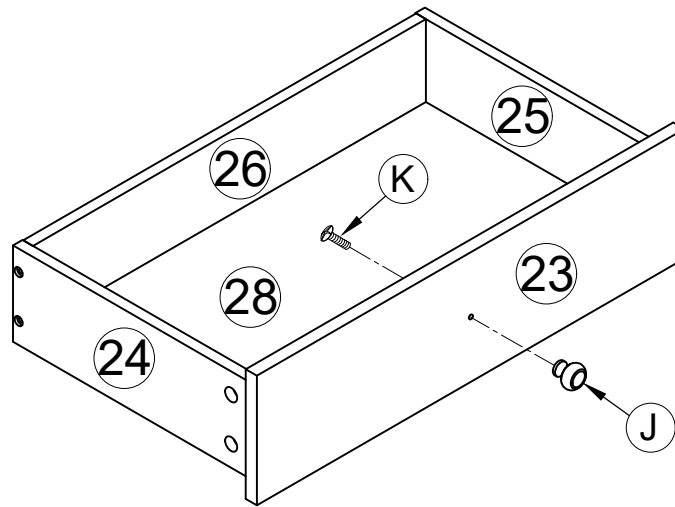

STEP 24 x2 Set

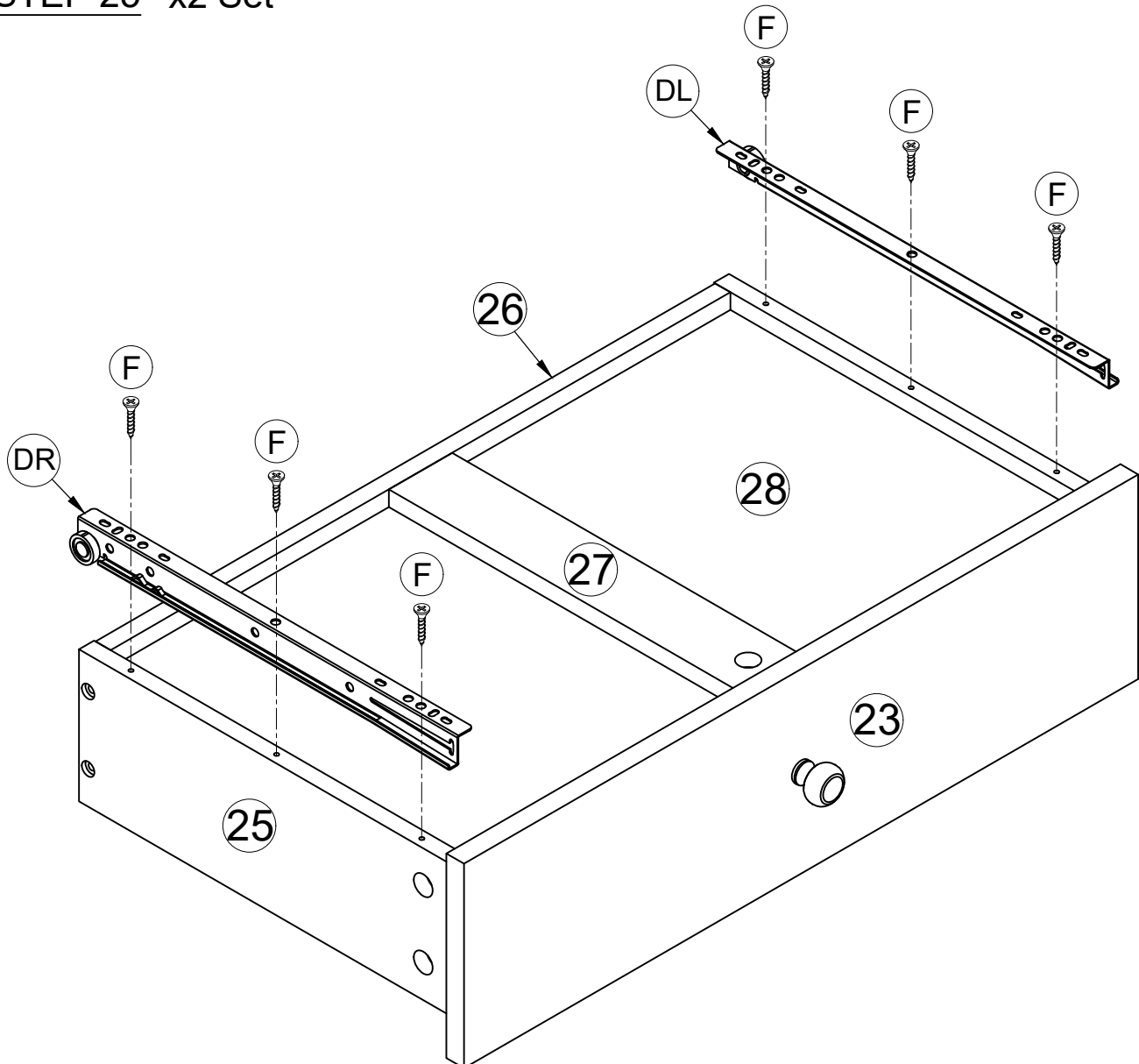

J		2PCS
K		2PCS

STEP 25 x2 Set



F		12PCS	DL		2PCS	DR		2PCS
---	---	-------	----	---	------	----	---	------

ASSEMBLY INSTRUCTIONS

STEP 26 x2 Set

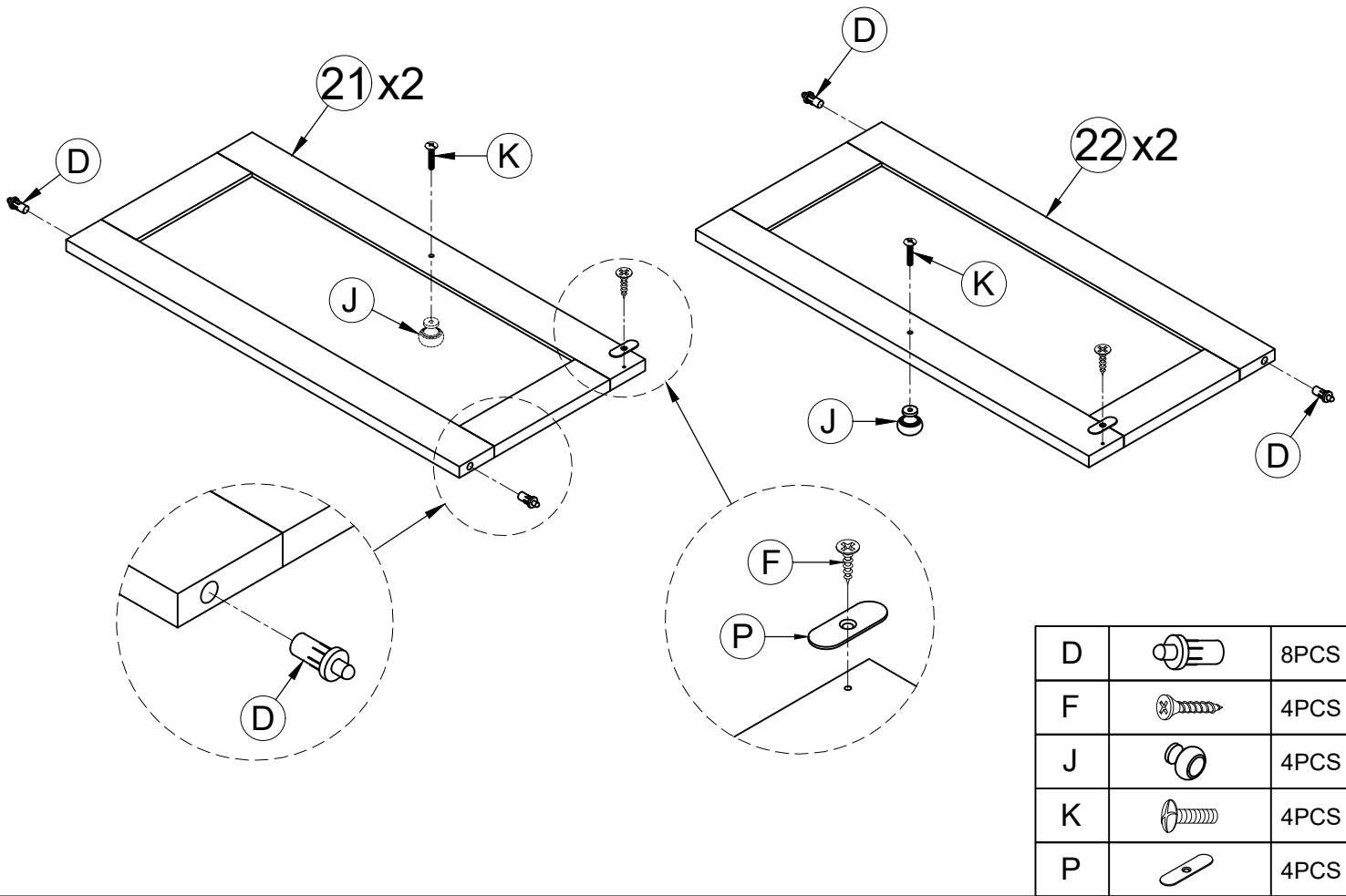

STEP 27

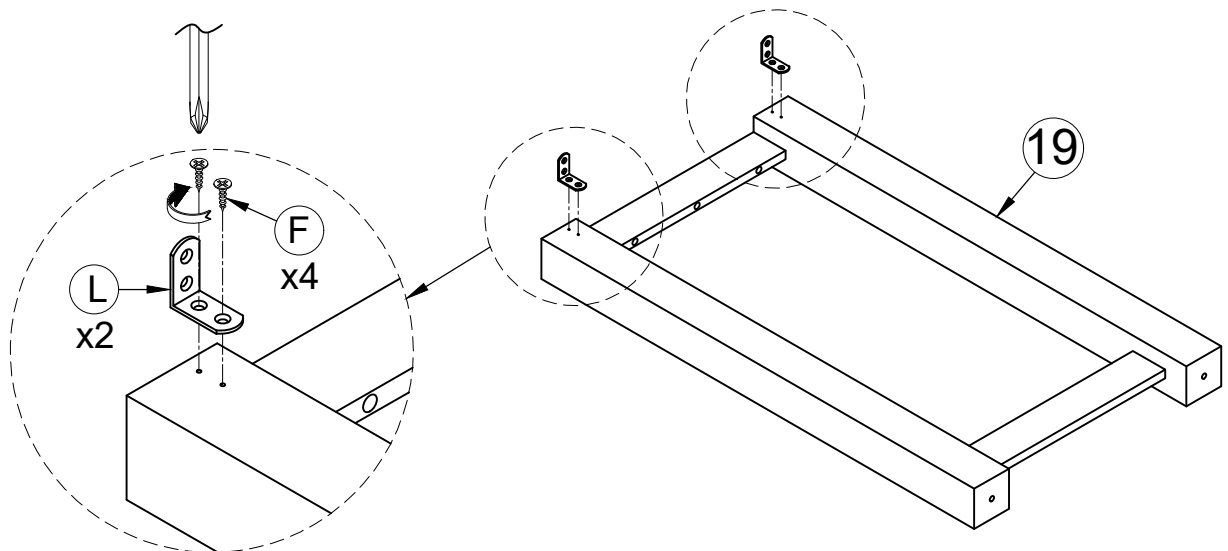

L		2PCS
F		4PCS

ASSEMBLY INSTRUCTIONS

STEP 28

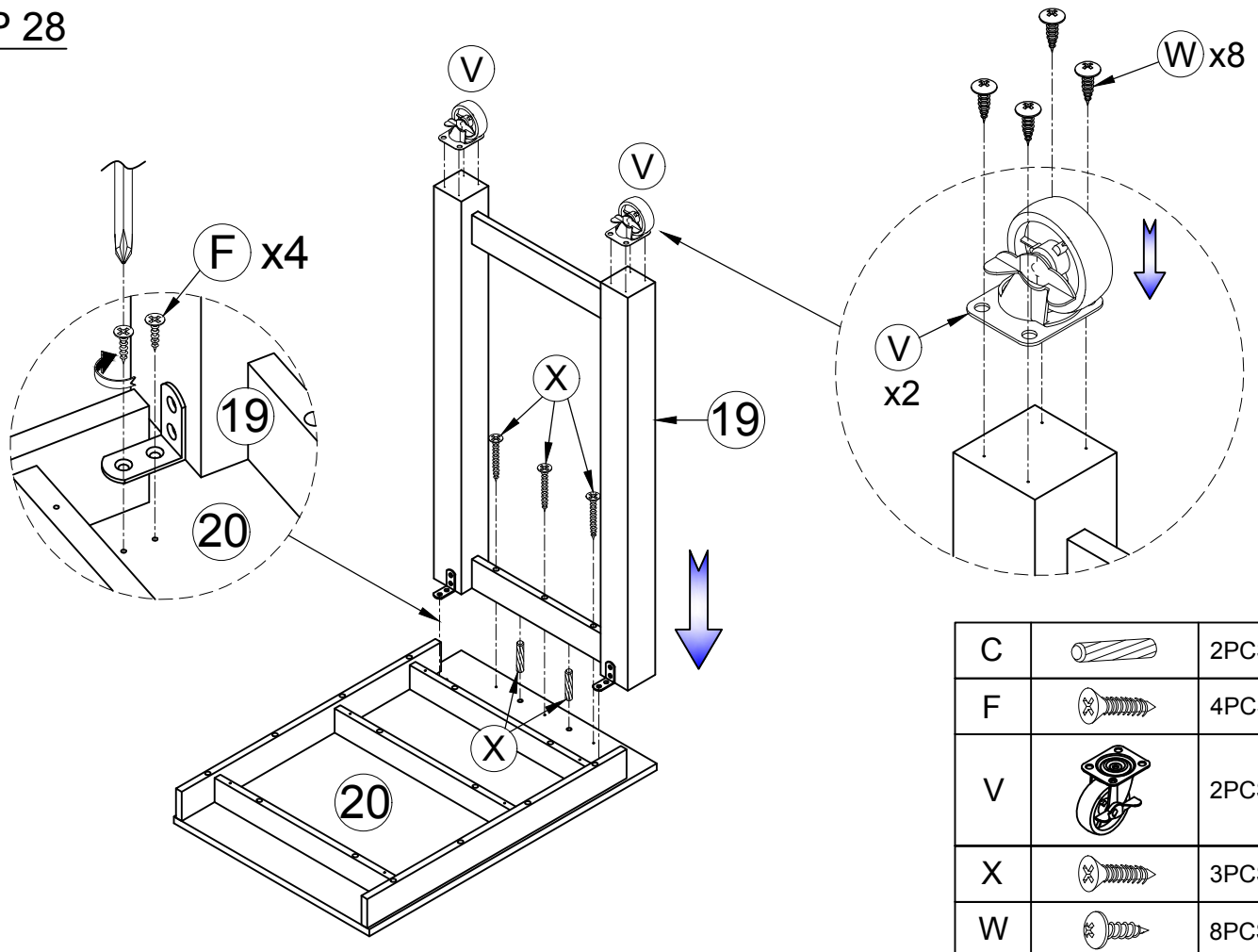

C		2PCS
F		4PCS
V		2PCS
X		3PCS
W		8PCS

STEP 29

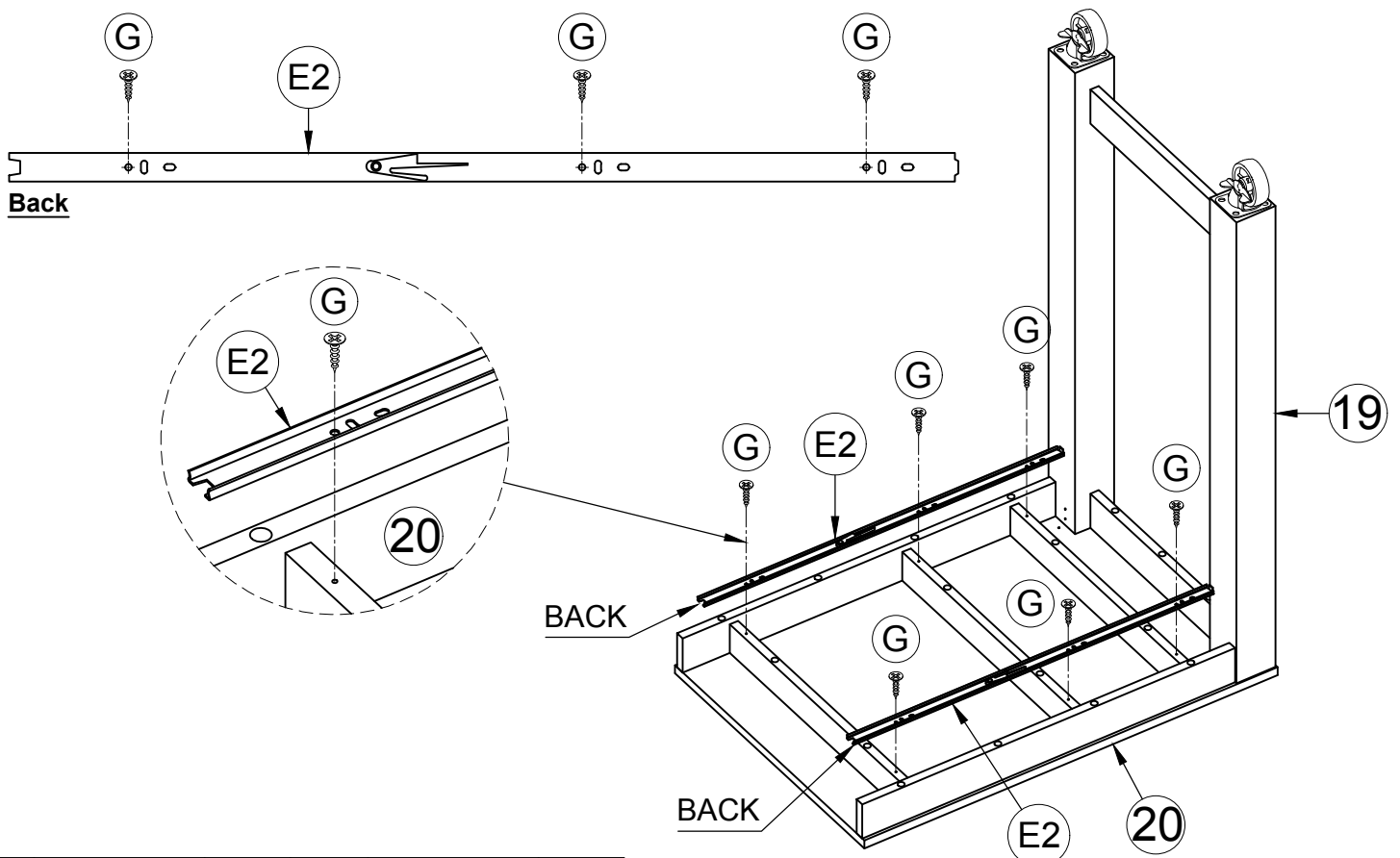

E2		2PCS	G		6PCS
----	--	------	---	--	------

ASSEMBLY INSTRUCTIONS

STEP 30

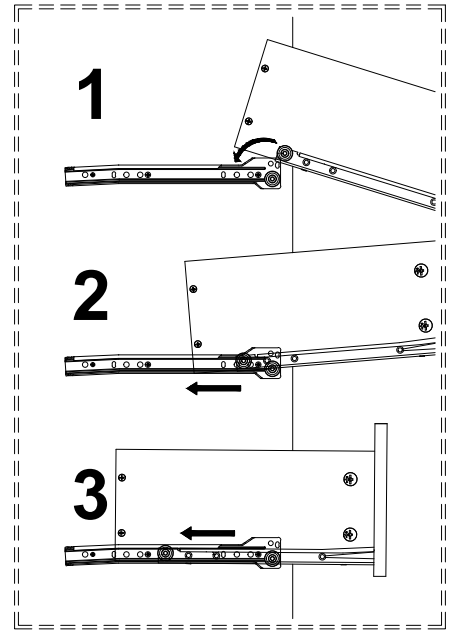
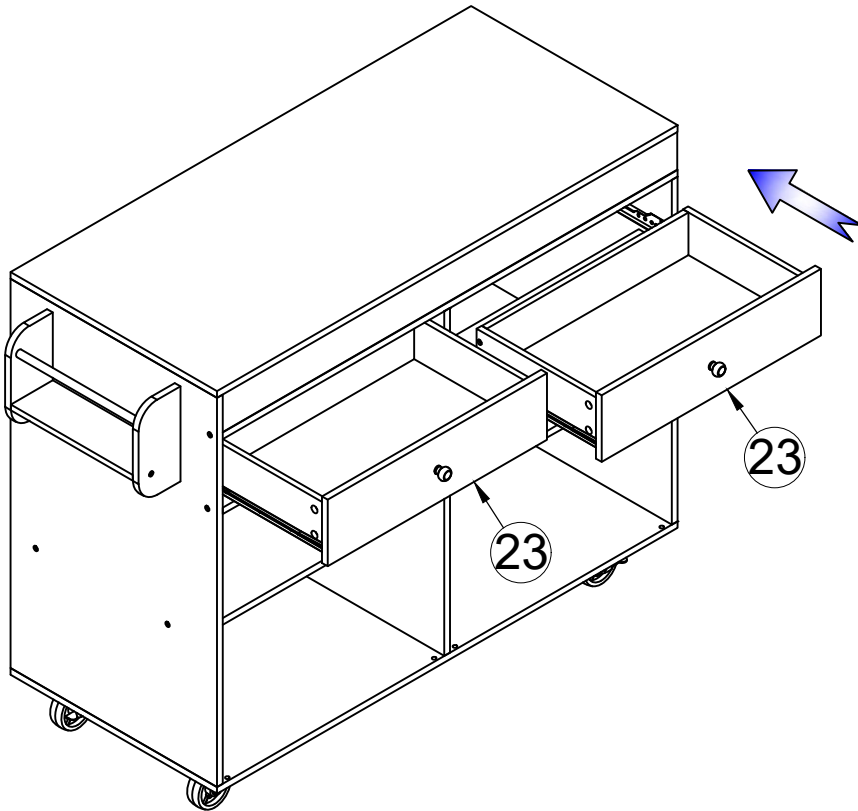

STEP 31

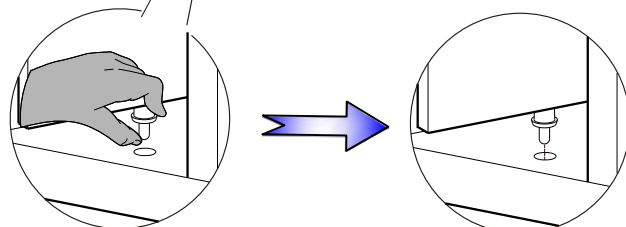
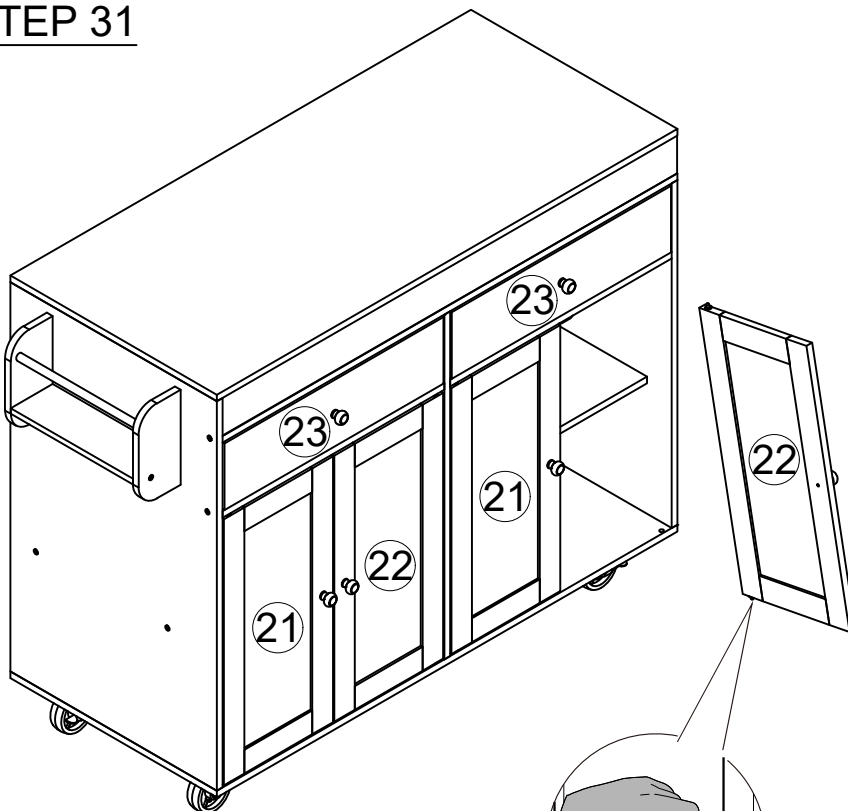

ASSEMBLY INSTRUCTIONS

STEP 32

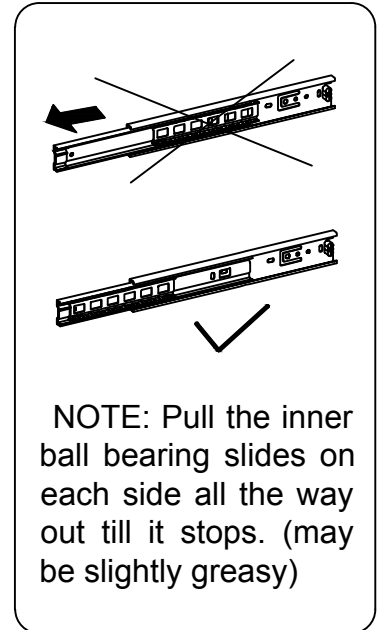
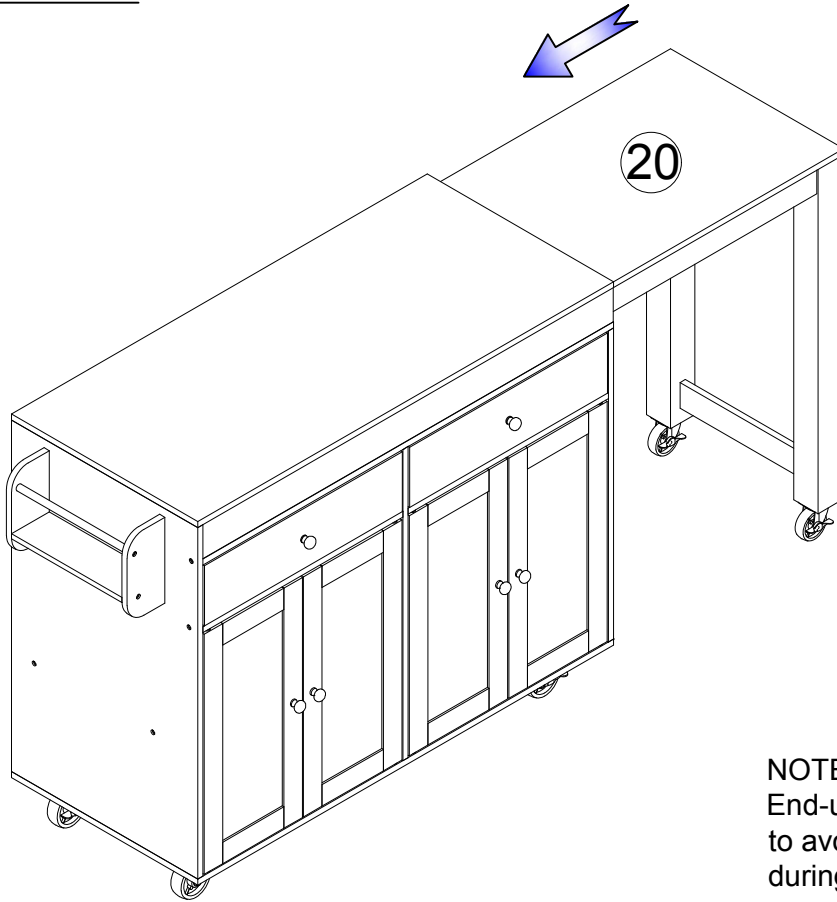

NOTE:
End-users must install on a flat surface to avoid wobbling or misalignment during assembly.

STEP 33

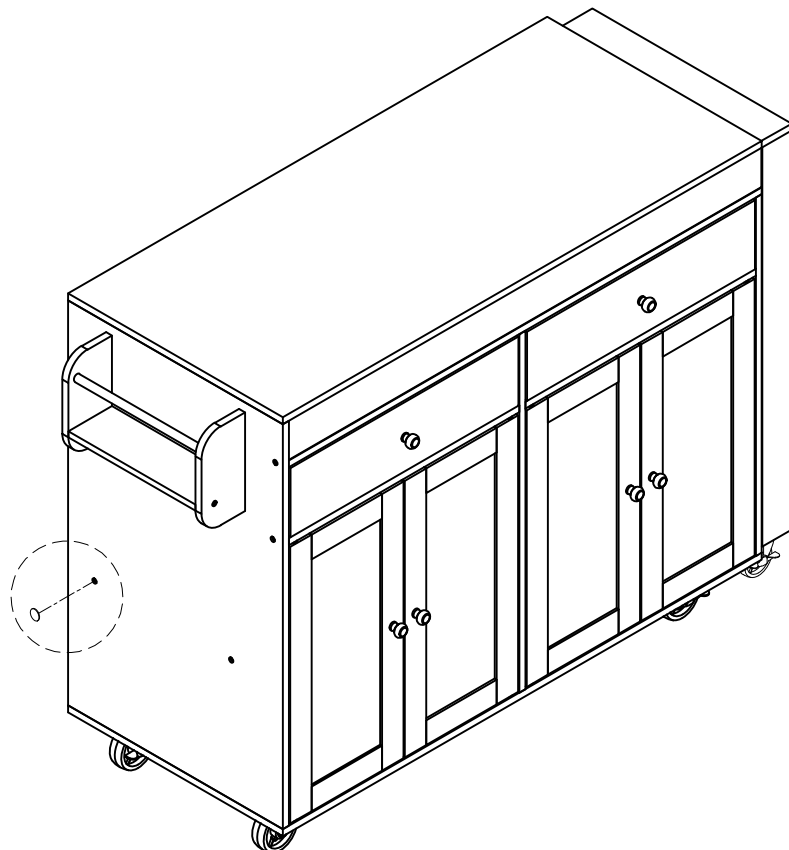

NOTE:
Cover all the holes on the cabinet body with stickers.

S



10PCS