

ASSEMBLY INSTRUCTIONS

Lewis End Table

ASSEMBLY

2 HOURS

2 -Person Assembly

Tools Required (Not Provided):

REQUIREMENTS

Assembly Time

(Approximate)



Phillips Screwdriver



Flat Head Screwdriver

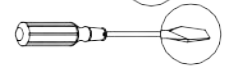

Thank you for purchasing our product!

Please refer and use this assembly instruction to assemble the product.

Contact our customer service department in case there are any missing or damage parts or hardware.

Replacement parts are normally shipped within 2 or 3 days.

THIS PRODUCT IS FOR INDOOR AND HOUSEHOLD USE ONLY-NOT FOR COMMERCIAL USE .

ASSEMBLY PREPARATION

1. Remove all packaging materials, staples and packing straps from the carton.
2. Refer to Parts List and Hardware List and ensure they are complete before you start assembling.
3. Place all wooden parts on a clean, flat and soft surface (e.g. carpet or rug) to prevent parts from getting scratched.

SAFETY PRECAUTION:

1. KEEP ALL HARDWARE PARTS OUT OF REACH OF CHILDREN.
2. DISPOSE PLASTIC PACKAGING MATERIAL IMMEDIATELY TO AVOID ANY RISK OF SUFFOCATION TO CHILDREN AND ANIMALS.

TIPS FOR ASSEMBLY:

1. Allow ample room for assembly and in close proximity to where product will be placed.
2. Assemble the product on a surface that does not scratch or damage the exterior gloss and finish of the furniture.
3. Please check all of the parts and quantities are included before assembly. Contact customer service for missing parts.
4. Identify all of the parts, hardware and quantities required for each step.
5. During assembly, do not over-tighten any fittings as this may cause damage.
6. DO NOT USE POWER TOOLS TO ASSEMBLE THIS PRODUCT.
7. Always place the product on a flat surface.
8. Do not sit or stand on the partially assembled product; only use the product for which it is intended.

CARE AND MAINTENANCE







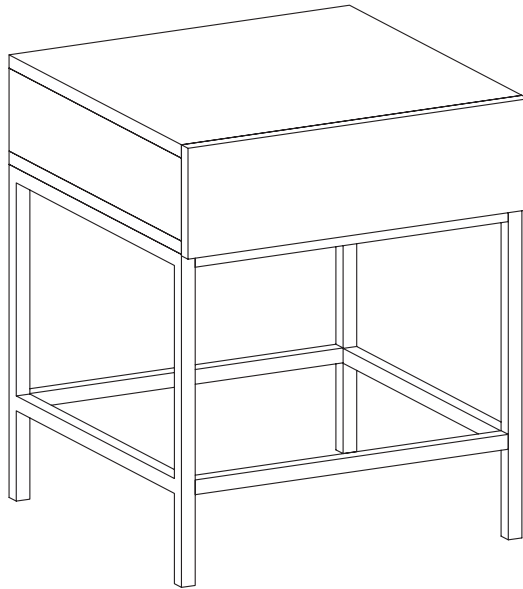

1. Wipe clean with a soft, dry cloth; avoid the use of harsh chemicals or household cleaners as they may damage the exterior finish of the furniture.
2. Hardware may loosen over time. Periodically, check that all connections are tight; re-tighten as necessary.
3. Solid wood is impacted by heat and humidity fluctuations which may cause small joint separations or hairline cracks; place the furniture away from direct sunlight and air conditioning vents, heating vents or units to protect the furniture.

ASSEMBLY INSTRUCTIONS

Lewis End Table/End Table



Hardware List

ITEM	DESCRIPTION	PART	QTY	ITEM	DESCRIPTION	PART	QTY
A	Cam-lock	 14*11mm	16PCS	F	Screw		8PCS
B	Cam-bolt	 5*40 mm	16PCS	G	Metal Glide	 4*12 mm	1 sets
C	Flat Washer	 6*16 mm	20PCS	H	Screw	 4*35mm	4PCS
D	Allen-Head Bolt	 6*15 mm	20PCS				
E	Allen Wrench		1PC				

CAM-BOLT and CAM-LOCK INSTRUCTIONS

CAM-LOCK



Align the arrow on the Cam-lock to the Cam-bolt head and insert the Cam-lock.

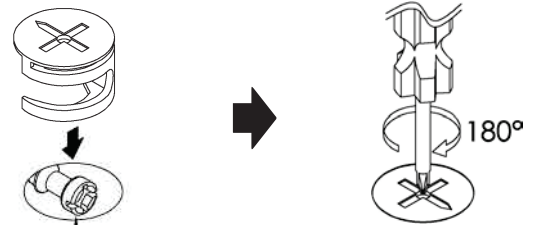
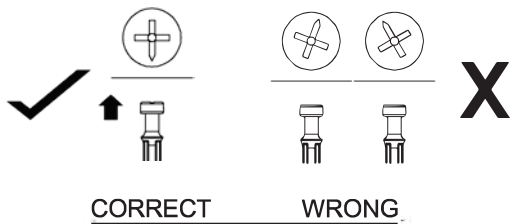

Use a flat screwdriver to turn the Cam-Lock clockwise one half a turn so it locks onto the head of the Cam-lock. Turn only until it is snug – over-tightening could damage Cam-lock or/and Cam-bolt

CAM-BOLT

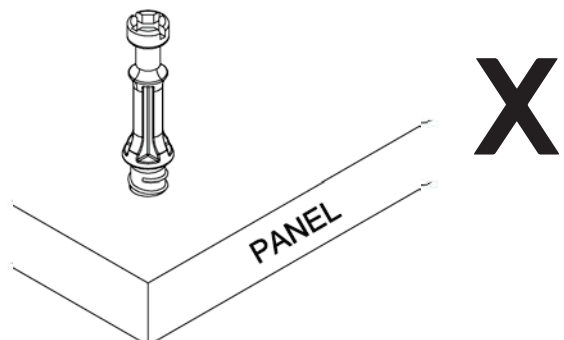
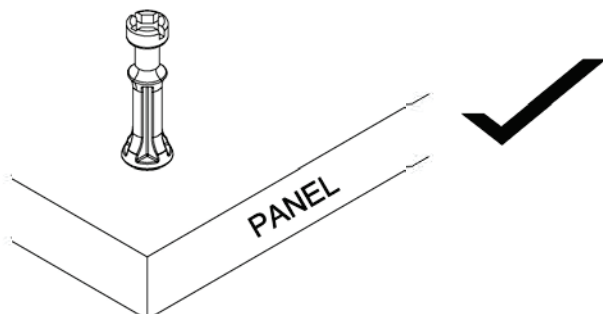
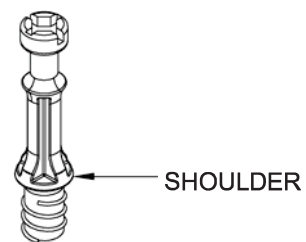

Insert Cam-bolt into the pre-drilled hole. Use a Phillips Screwdriver to tighten until shoulder is flush with the panel. See illustrations below.

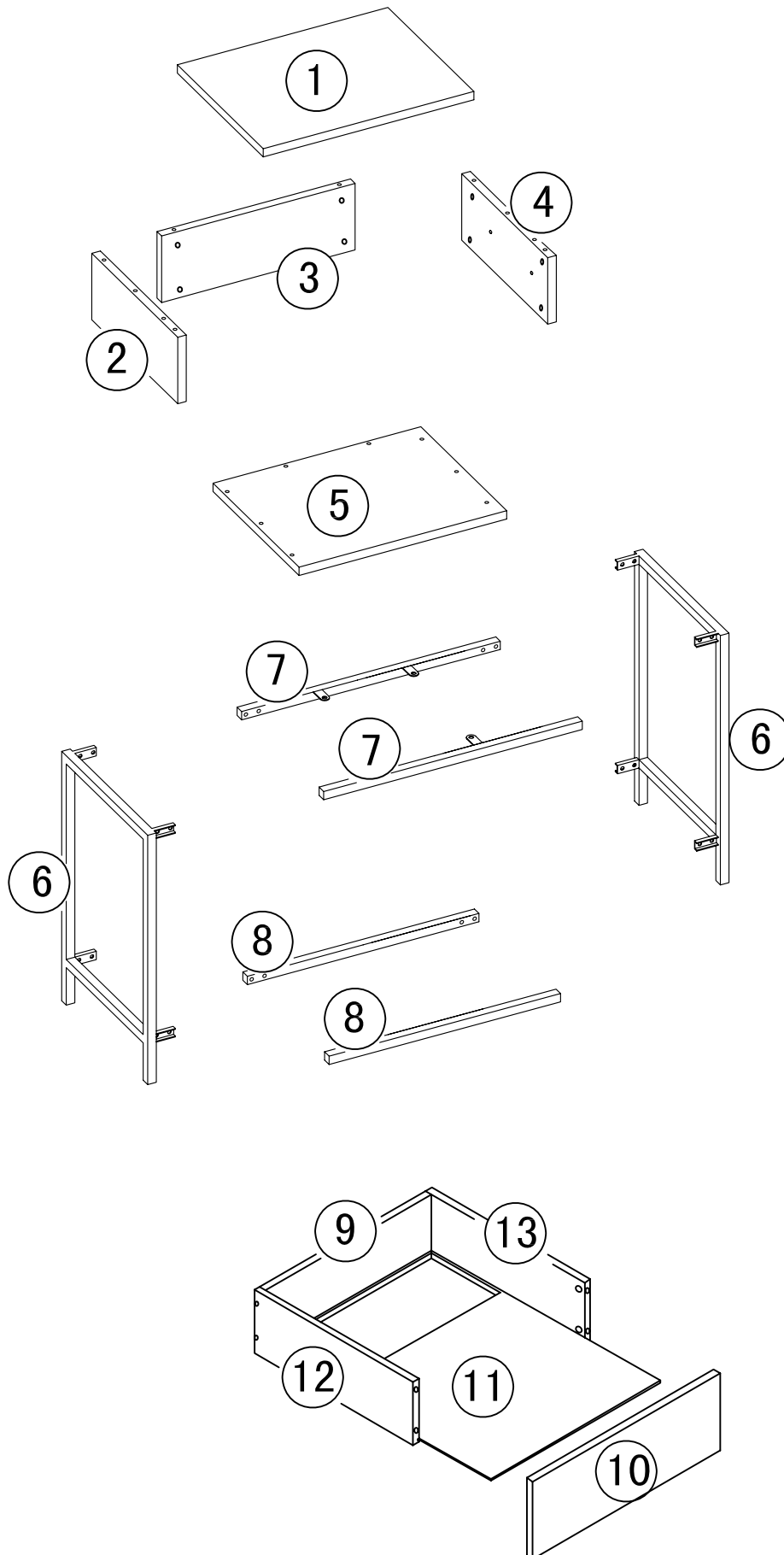

Parts & Assembly Overview

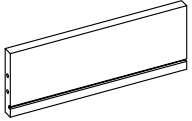
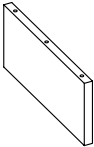
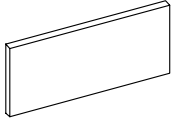
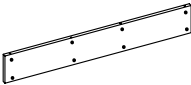
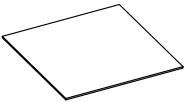
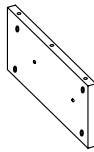
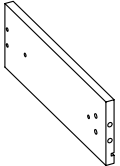
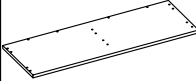
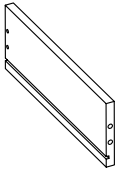
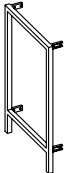
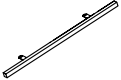

Parts List

ITEM	DESCRIPTION	PART	QTY	ITEM	DESCRIPTION	PART	QTY
1	Top Panel		1 PC	9	Drawer Back Panel		1 PC
2	Left Side Panel		1 PC	10	Drawer Front Panel		1 PC
3	Back Panel		1 PC	11	Drawer Bottom Panel		1 PC
4	Right Side Panel		1 PC	12	Drawer Left Side Panel		1 PC
5	Bottom Base		1 PC	13	Drawer Right Side Panel		1 PC
6	Leg		2 PCS				
7	Connect Base		2 PCS				
8	Connect Base		2 PCS				

STEP 1

1. Distinguish Metal Glide (G) between Part A and Part B.

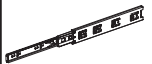

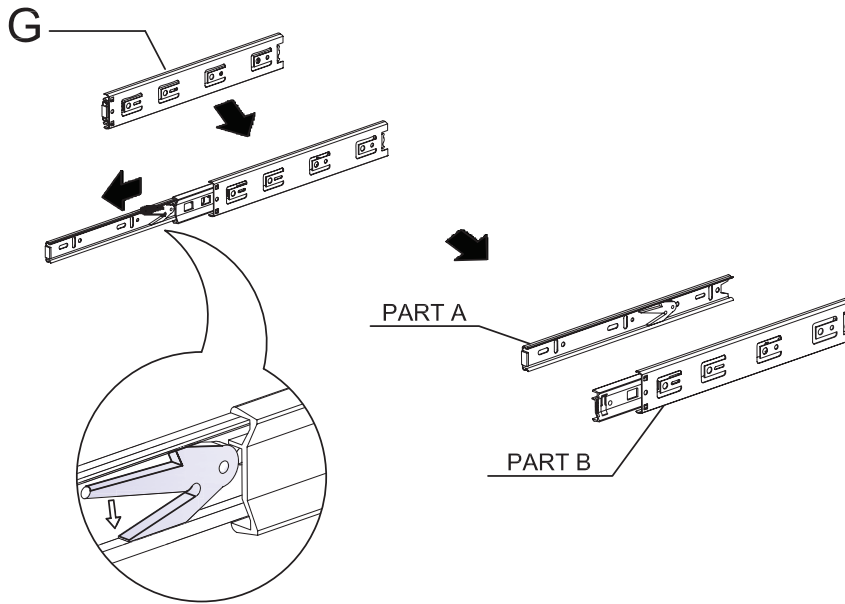
G		2 sets
---	-------------------------------------------------------------------------------------	--------



Push Lever downwards to slide out Part A

X 2

STEP 2

A		4 pcs
B		4 pcs

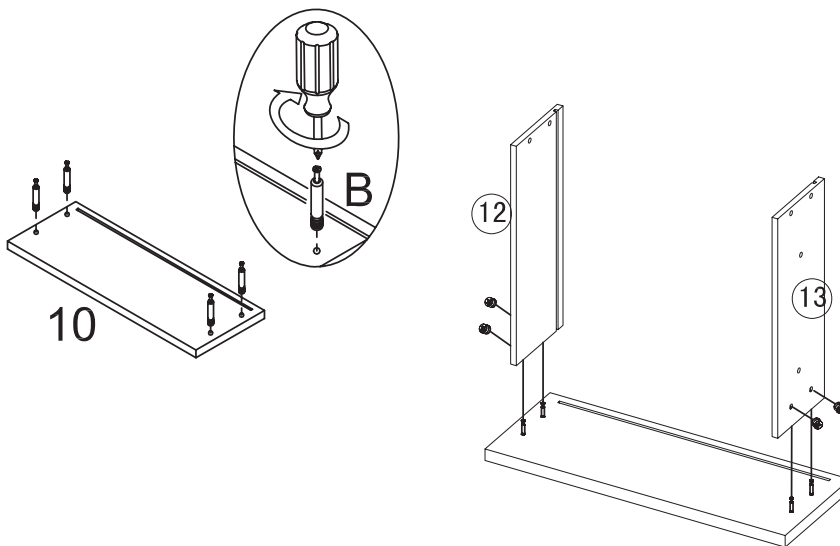

DO NOT USE POWER TOOLS

1. Attach Cam-bolt (B) to Drawer Front Panel (10). (Refer to page on Cam-bolt and Cam-lock Instructions)
2. Attach Drawer Left & Right Side Panels (12 & 13) to Drawer Front Panel (10). Next, insert Cam-lock (A) to (12 & 13) then turn clockwise to lock Cam-bolt. (Refer to page on Cam-bolt and Cam-lock Instructions.)

STEP 3

H		4 pcs
---	-------------------------------------------------------------------------------------	-------

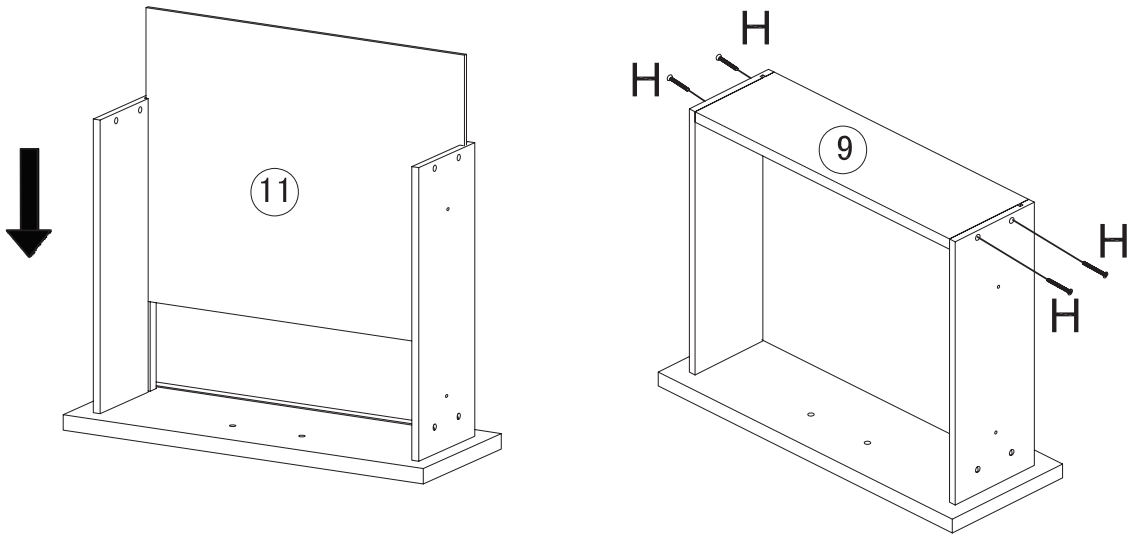

1. Insert Drawer Bottom Panel (11) by fitting (11) into the groove on Drawer Front & Side Panels.
2. Attach Drawer Back Panel (9) to Drawer Side Panel (12 & 13) by using Screw (H).

STEP 4

F		8 pcs
---	---------------------------------------------------------------------------------------	-------

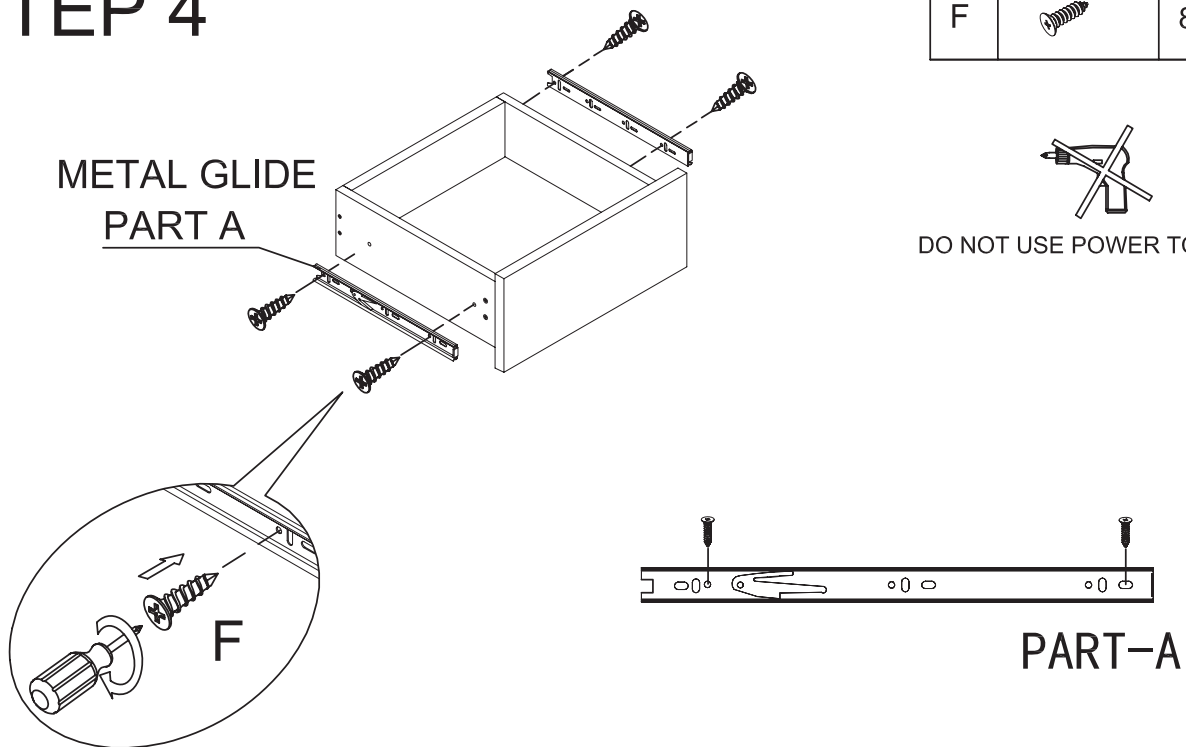

1. Install Part A of Metal Glide (G) to pilot holes on drawer by using Screw (F).

STEP 5

A		8 pcs
---	-------------------------------------------------------------------------------------	-------

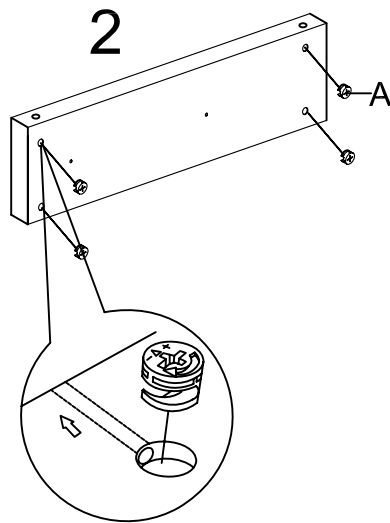

DO NOT USE POWER TOOLS

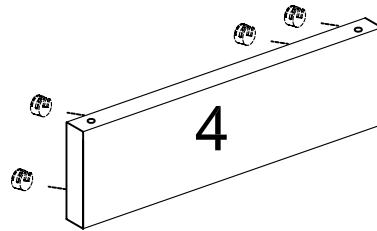

1. Put Cam-lock (A) into pilot holes on Left Side Panel (2) and Right Side Panel (4),
NOTE: The arrow on the cap is pointing in the direction of the hole .

STEP 6

F		4 pcs
---	---------------------------------------------------------------------------------------	-------

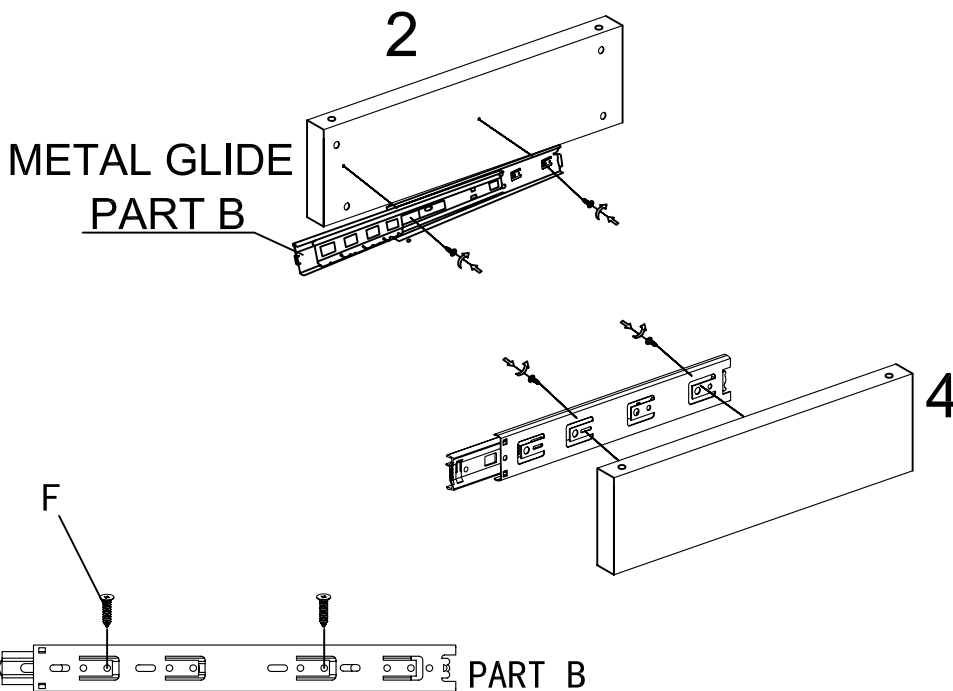

DO NOT USE POWER TOOLS

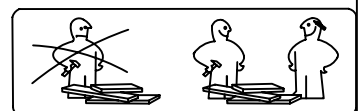



Refer to page on Cam-bolt and Cam-lock Instructions.

1. Install Part B of Metal Glide (G) to pilot holes on Left Side Panel (2) and Right Side Panel (4) by using Screw (F) .

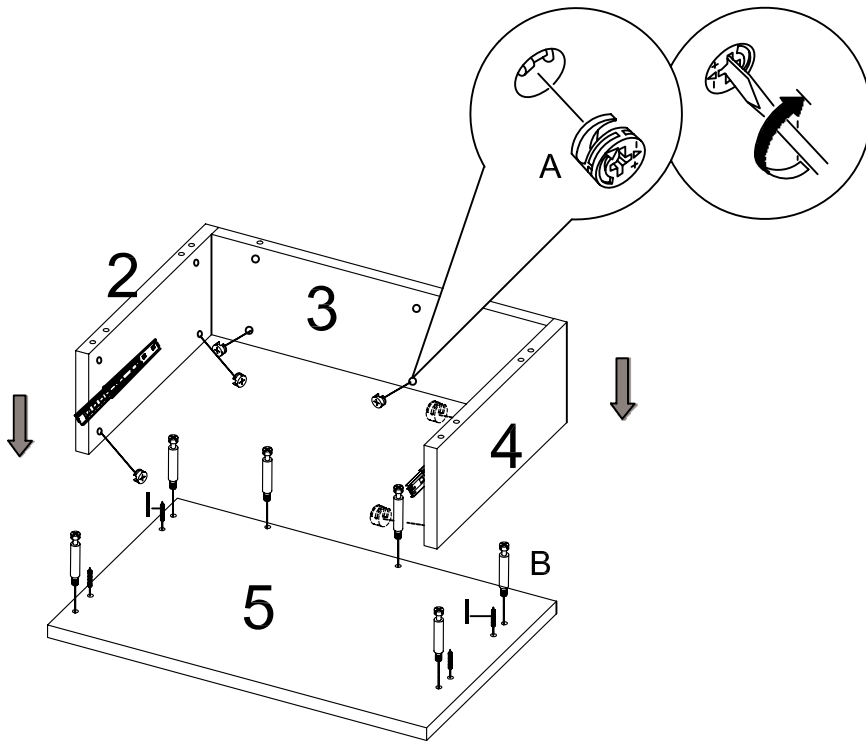
STEP 7



A		2 pcs
B		6 pcs



DO NOT USE POWER TOOLS

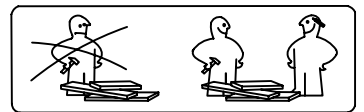



Refer to page on Cam-bolt and Cam-lock Instructions.

1. Attach Cam-bolt (B) & Wood dowel (I) to all of the pre-drilled holes on Bottom Base (5).
2. Install Panel (2), (3) & (4) from Step 6 to Bottom Panel (5). Secure with Cam-lock (A).

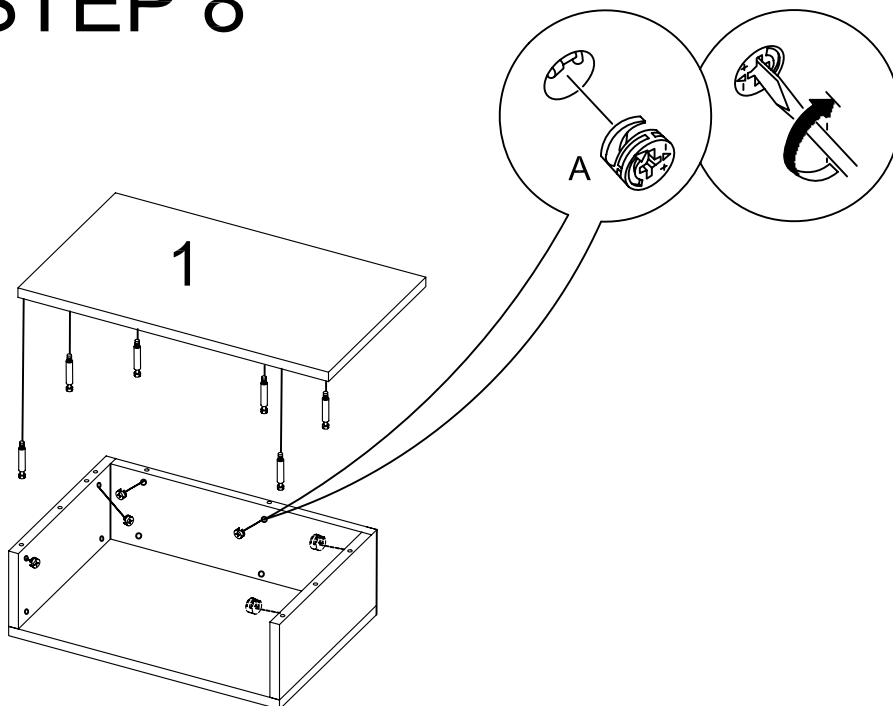
STEP 8



A		2 pcs
B		6 pcs

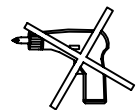

DO NOT USE POWER TOOLS

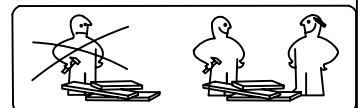

Refer to page on Cam-bolt and Cam-lock Instructions.

1. Attach Cam-bolt (B) & Wood dowel (I) to all of the pre-drilled holes on Top Panel (1).
2. Install Top Panel (1) as shown. Secure with Cam-lock (A)

STEP 9

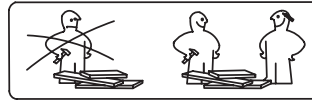

C		4 pcs
D		4 pcs
E		1pc

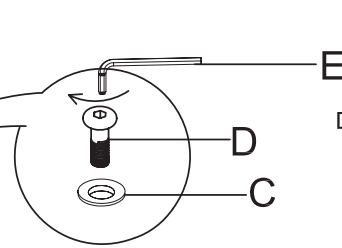
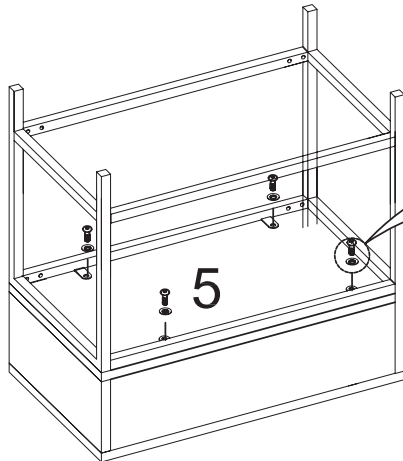

1. Place the sub-assembly completed in Step 8 bottom-side up (with Bottom Base (5) face up.)
2. Place Leg assembly from Step 9 bottom-side up and directly over Bottom Base (5) as shown.
3. Use Allen-Head Bolt (D) and Lock Washer (C) to attach Connect Base of Leg assembly to Bottom Base (5). Tighten Bolt (D) by using Allen Wrench (E)

STEP 10

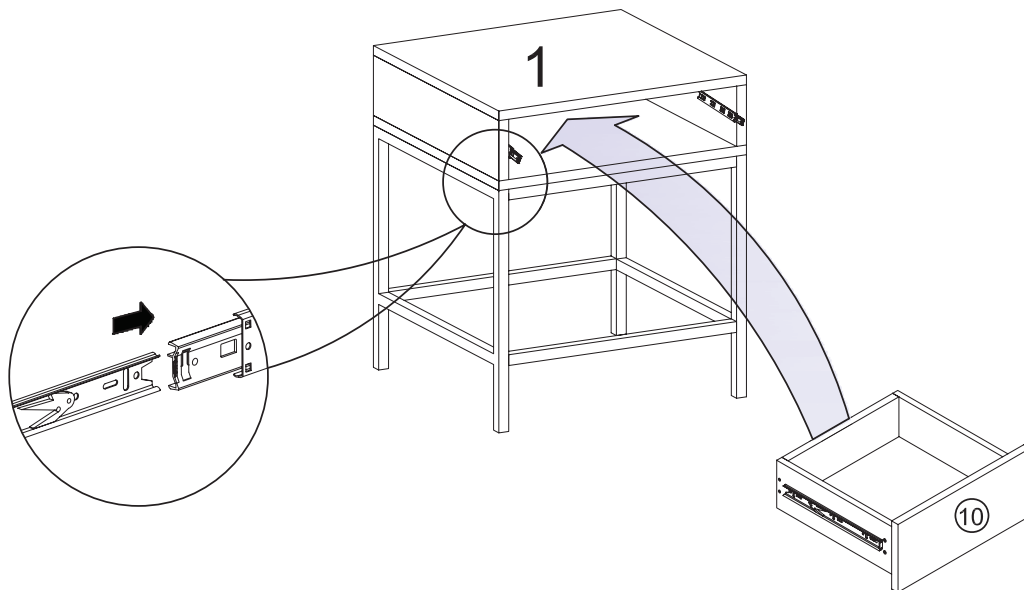

1. Insert drawers as shown.

FINISH

