

Assembly Instructions

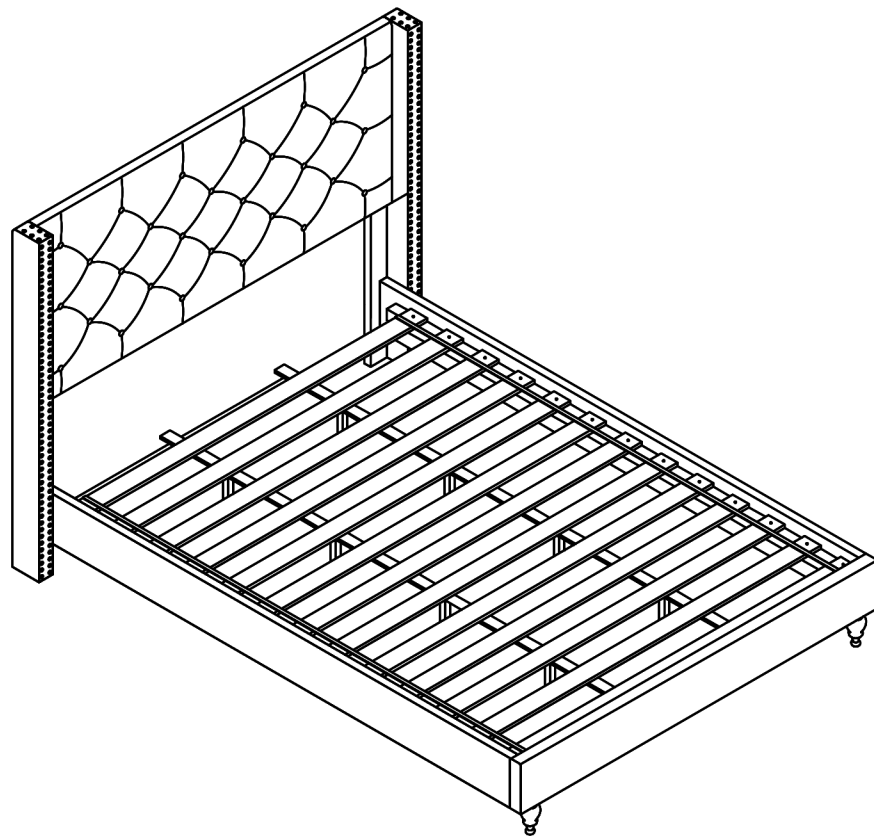

ASSEMBLY RATING

The Assembly Rating is a 5-point system that shows the degree of effort needed in assembling a specific product (with 1 being easy and 5 being difficult). For some products, two persons are recommended.

EASY  DIFFICULT

Tools Required For Assembly:

Allen Wrench

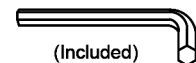

Phillips Screwdriver



2 PERSONS RECOMMENDED

ASSEMBLY & CARE ADVICE

FOR YOUR FURNITURE TO LAST, CORRECT ASSEMBLY AND PROPER MAINTENANCE ARE NECESSARY. PLEASE FOLLOW THE INFORMATION PROVIDED BELOW TO FULLY ENJOY YOUR FURNITURE.

BASIC ASSEMBLY TECHNIQUES

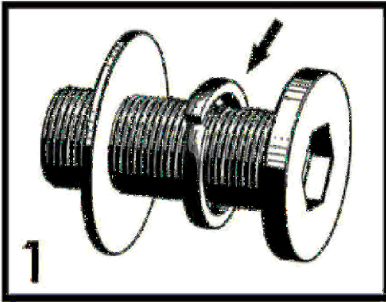

1
When lock or spring washer is used in an assembly, please make sure the lock or spring washer is placed between the larger flat washer and the head of the screw or bolt.

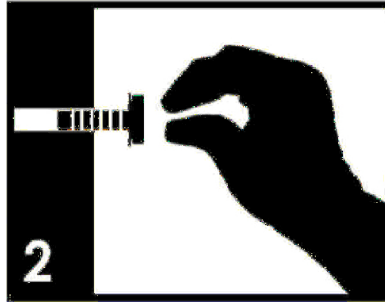

2
Position each part correctly and insert screws or bolts into their respective holes by hand tighten or using the proper hand tool. Only tighten when step is completed or when instructed to do so.

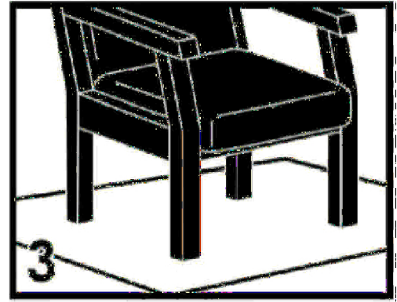

3
Use cardboard or carpet area when assembling furniture to prevent scratches. Make sure the furniture rests on a flat and level surface with each leg evenly touching the floor. No dragging of products/parts.



4
Some furniture comes with height adjustment knobs underneath each leg. To lower or to raise each leg, you need to turn clockwise or counterclockwise, respectively.

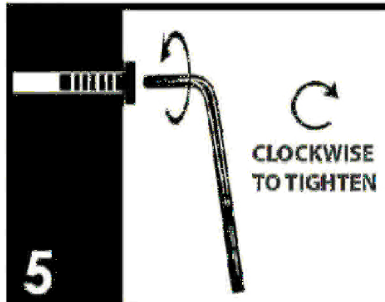

5
Make sure all parts are properly aligned, then use the appropriate hand tool to completely tighten the bolts or screws. Do not use power tools and do not overtighten.

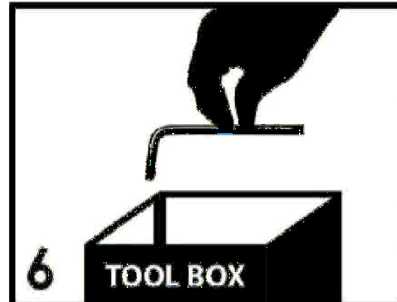

6
Save the instructions and store the Allen wrench or any supplied tool for later maintenance. After two weeks, check and tighten any loose hardware and repeat again every six months thereafter.

IT IS THE USER'S RESPONSIBILITY TO MAINTAIN THE FURNITURE. THE HARDWARE MAY LOOSEN OVER TIME AND MAY CAUSE THE FURNITURE TO BE WOBBLY AND UNABLE TO SUPPORT ITS INTENDED WEIGHT CAPACITY. THIS MAY LEAD TO COLLAPSE AND MAY CAUSE SERIOUS INJURY.





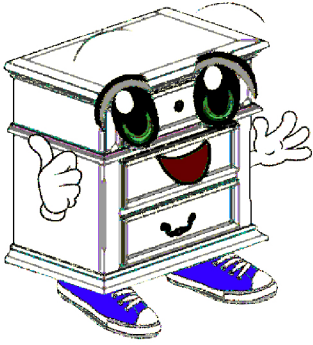



FAILURE TO FOLLOW THE GUIDELINES ABOVE MAY RESULT IN INJURY AND/OR PROPERTY DAMAGE.



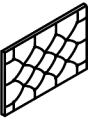
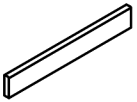



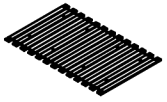



Before you begin, please read Page 2 of "Assembly and Care Advice".

And remember, do not tighten until each step is completed or instructed.

Parts List

	#1 x 1pc Headboard
	#2 x 1pc Footboard
	#3 x 2pcs Side Rail
	#4 x 2pcs Wings(L&R)
	#5 x 2pcs Headboard Leg (L & R)
	#6 x 2pcs Footboard Feet
	#7 x 1set Slat (13pcs)
	#8 x 8pcs Ø5/16" Support Leg 225x30x30mm
	#9 x 2pcs Support Rail

Hardware List

	#A x 1pc Allen Key 5mm
	#B x 4pcs Bolt Ø5/16" x 1-1/2"
	#C x 8pcs Bolt Ø5/16" x 2"
	#D x 4pcs Bolt Ø5/16" x 2-1/2"
	#E x 2pcs Bolt Ø5/16" x 4"
	#F x 8pcs Flat Washer Ø5/16" x 19mm
	#G x 10pcs Flat Washer Ø5/16" x 22mm
	#H x 18pcs Spring Washer Ø5/16"
	#I x 26pcs Screw #8 x 38mm

Exploded View

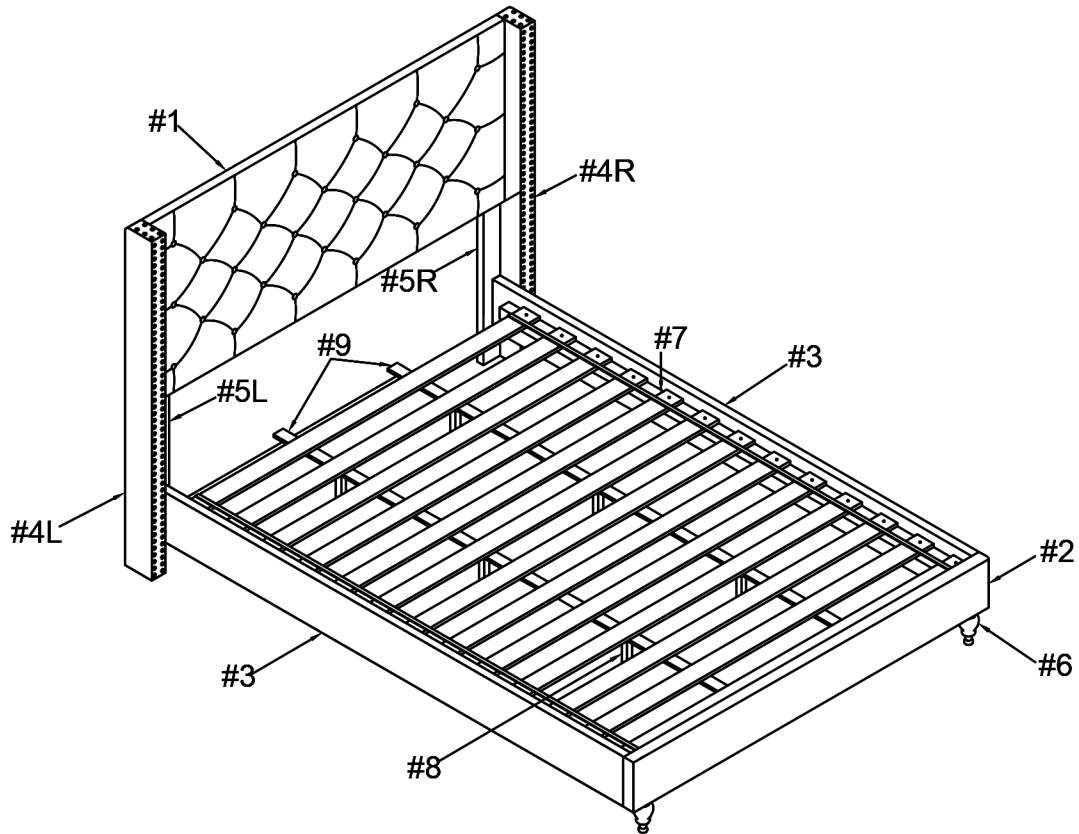

#1

Remove legs (#5) in the compartment of the headboard (#1).

#C x 4pcs
#H x 4pcs
#G x 4pcs

Align HB legs (#5R/L) to the headboard (#1), then secure by using bolts (#C) with washers (#H,G).

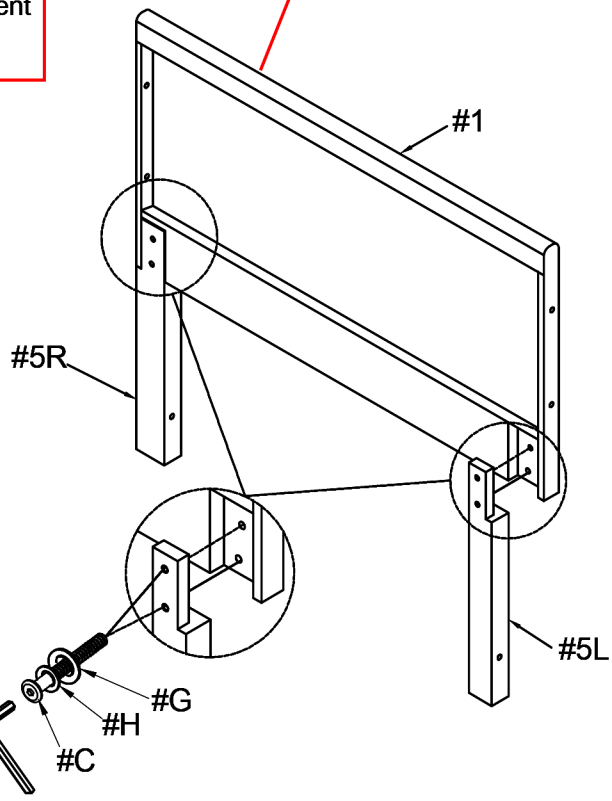
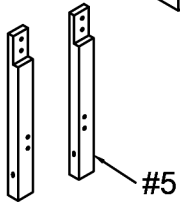
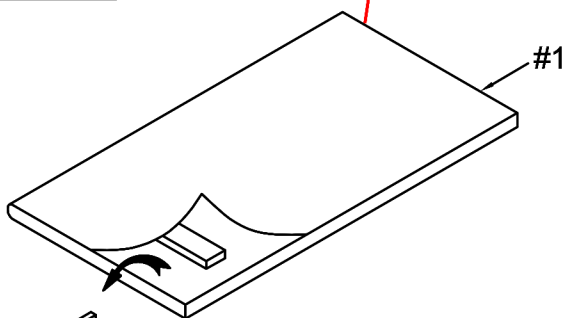



Attach FB legs (#6) to the footboard (#2).

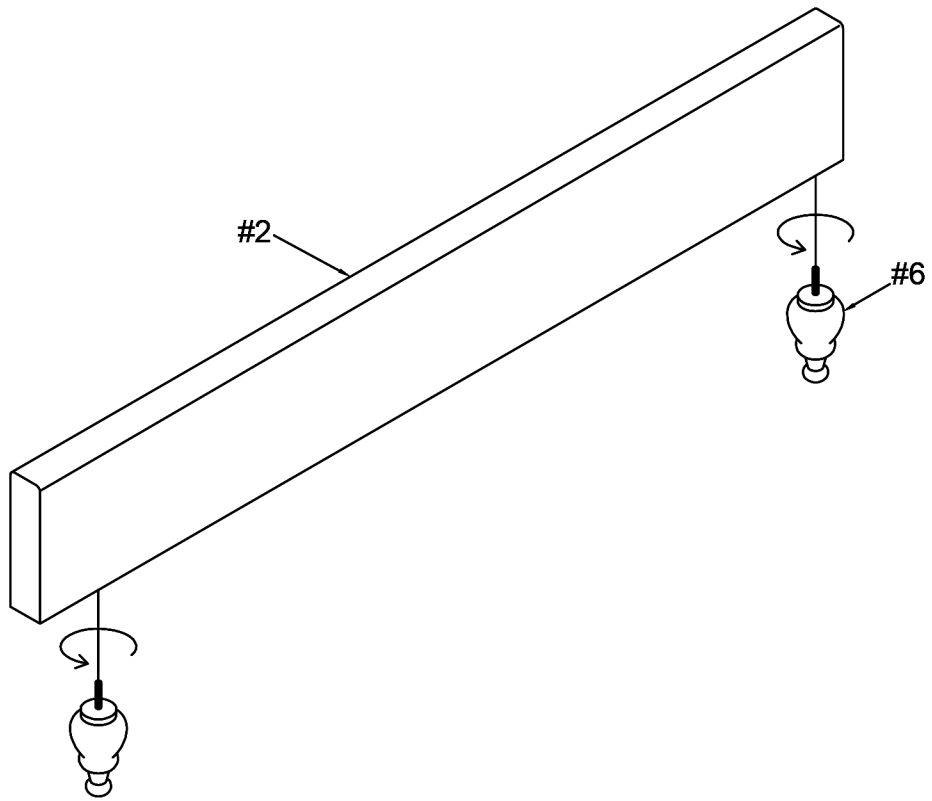

Align side rails (#3) to the headboard (#1) and footboard (#2), then secure by using bolts (#D) with washers (#H,F).

- #B x 4pcs
- #D x 4pcs
- #H x 8pcs
- #F x 8pcs

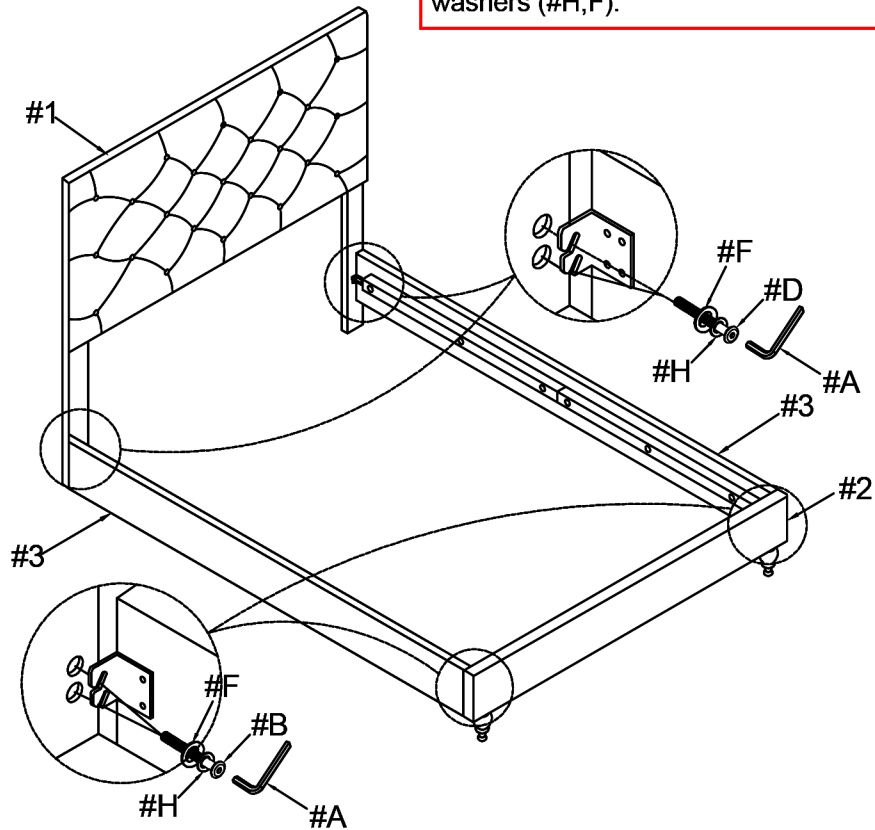



Align wings (#4R/L) to the headboard (#1), then secure by using bolts (#C,E) with washers (#H,G) as shown in the diagram.

- #C x 4pcs
- #E x 2pcs
- #G x 6pcs
- #H x 6pcs

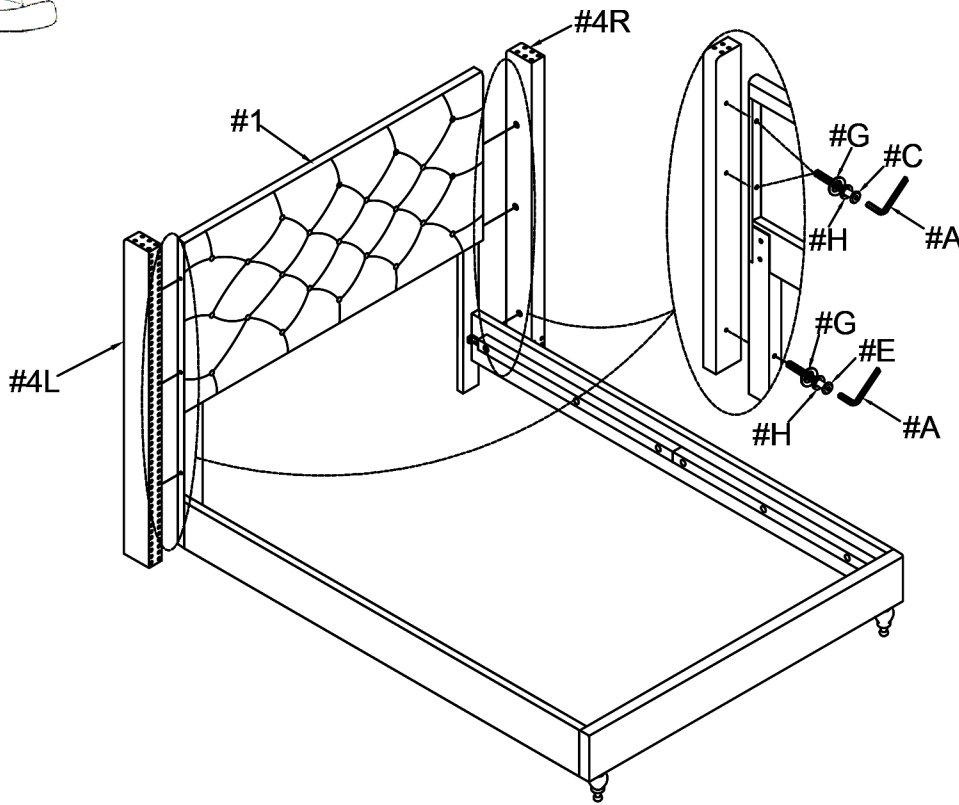

Align center slats (#9) to the slats (#7), then secure by using support legs (#8).
Adjust the leveler of the support legs (#8) according to ground level.

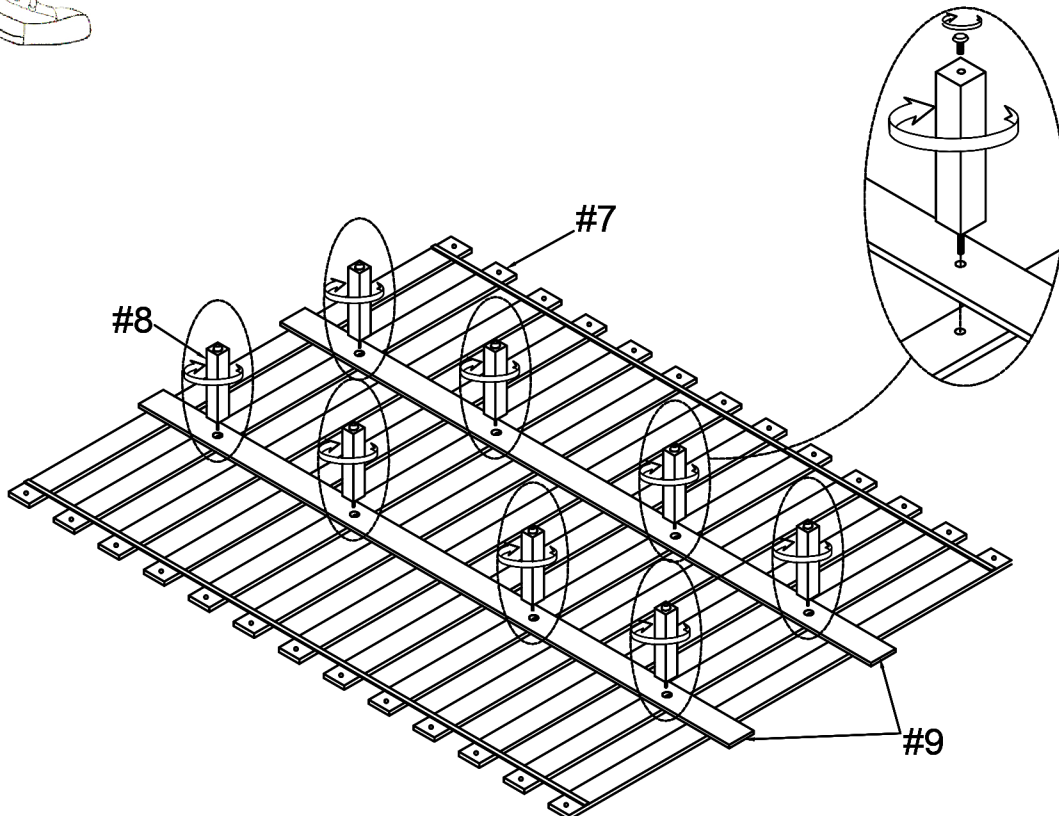



#1 x 26pcs

Align slats (#7) to the side rails (#3), then secure by using screws (#1).

