

Assembly Instructions

For more information contact our team

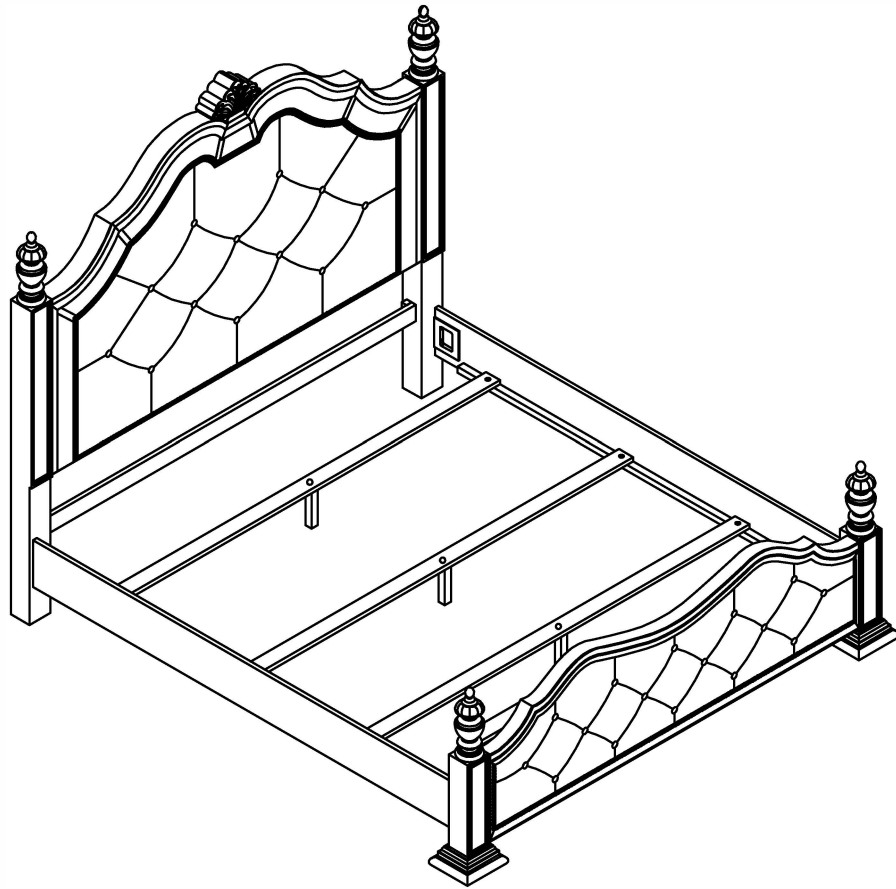

ASSEMBLY RATING

The Assembly Rating is a 5-point system that shows the degree of effort needed in assembling a specific product (with 1 being easy and 5 being difficult). For some products, two persons are recommended.

EASY



DIFFICULT

Tools Required For Assembly:

Allen Wrench

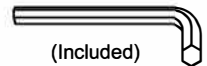

(Included)

Wrench



(Included)

Phillips Screwdriver



(Not Included)



2 PERSONS RECOMMENDED

ASSEMBLY & CARE ADVICE

FOR YOUR FURNITURE TO LAST, CORRECT ASSEMBLY AND PROPER MAINTENANCE ARE NECESSARY. PLEASE FOLLOW THE INFORMATION PROVIDED BELOW TO FULLY ENJOY YOUR FURNITURE.

BASIC ASSEMBLY TECHNIQUES



When lock or spring washer is used in an assembly, please make sure the lock or spring washer is placed between the larger flat washer and the head of the screw or bolt.



Position each part correctly and insert screws or bolts into their respective holes by hand tighten or using the proper hand tool. Only tighten when step is completed or when instructed to do so.



Use cardboard or carpet area when assembling furniture to prevent scratches. Make sure the furniture rests on a flat and level surface with each leg evenly touching the floor.



Some furniture comes with height adjustment knobs underneath each leg. To lower or to raise each leg, you need to turn clockwise or counterclockwise, respectively.



Make sure all parts are properly aligned, then use the appropriate hand tool to completely tighten the bolts or screws. Do not use power tools and do not overtighten.



Save the instructions and store the Allen wrench or any supplied tool for later maintenance. After two weeks, check and tighten any loose hardware and repeat again every six months thereafter.

IT IS THE USER'S RESPONSIBILITY TO MAINTAIN THE FURNITURE. THE HARDWARE MAY LOOSEN OVER TIME AND MAY CAUSE THE FURNITURE TO BE WOBBLY AND UNABLE TO SUPPORT ITS INTENDED WEIGHT CAPACITY. THIS MAY LEAD TO COLLAPSE AND MAY CAUSE SERIOUS INJURY.



FAILURE TO FOLLOW THE GUIDELINES ABOVE MAY RESULT IN INJURY AND/OR PROPERTY DAMAGE.



Before you begin, please read Page 2 of "Assembly and Care Advice".

And remember, do not tighten until each step is completed or instructed.

Parts List

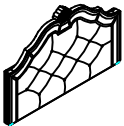

#1 x 1pc
Headboard Panel

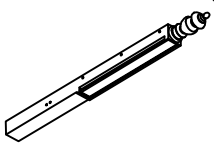

#2 x 2pcs
HB Leg (L&R)

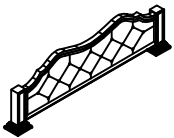

#3 x 1pc
Footboard

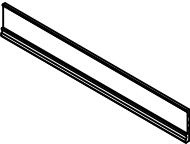

#4 x 2pcs
Side Rail



#5 x 1pc
Headboard Support



#6 x 3pcs
Bed Slat

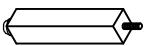

#7 x 3pcs $\text{Ø}1/4"$
Support Leg 30x30x165mm



#8 x 2pcs
Footboard Post

Hardware List



#A x 10pcs
Bolt $\text{Ø}5/16"$ x 2"



#B x 10pcs
Lock Washer $\text{Ø}5/16"$



#C x 10pcs
Flat Washer $\text{Ø}5/16"$



#D x 1pc
Allen Key 4mm

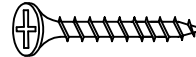

#E x 6pcs
Screw #4 x 1-3/16"



#F x 8pcs
Threaded Pins $\text{Ø}5/16"$ x 3-1/2"

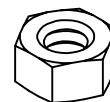

#G x 8pcs
Hex Nut $\text{Ø}5/16"$

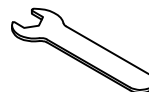

#H x 1pc
Wrench 14mm



Prepare 10 bolts assembly by inserting lock washer (#B), then flat washer (#C) onto bolts (#A). Align headboard (#1) and headboard support (#5) to the holes of the headboard legs (#2R/L), then secure with bolts (#A).

A x 10pcs
B x 10pcs
C x 10pcs

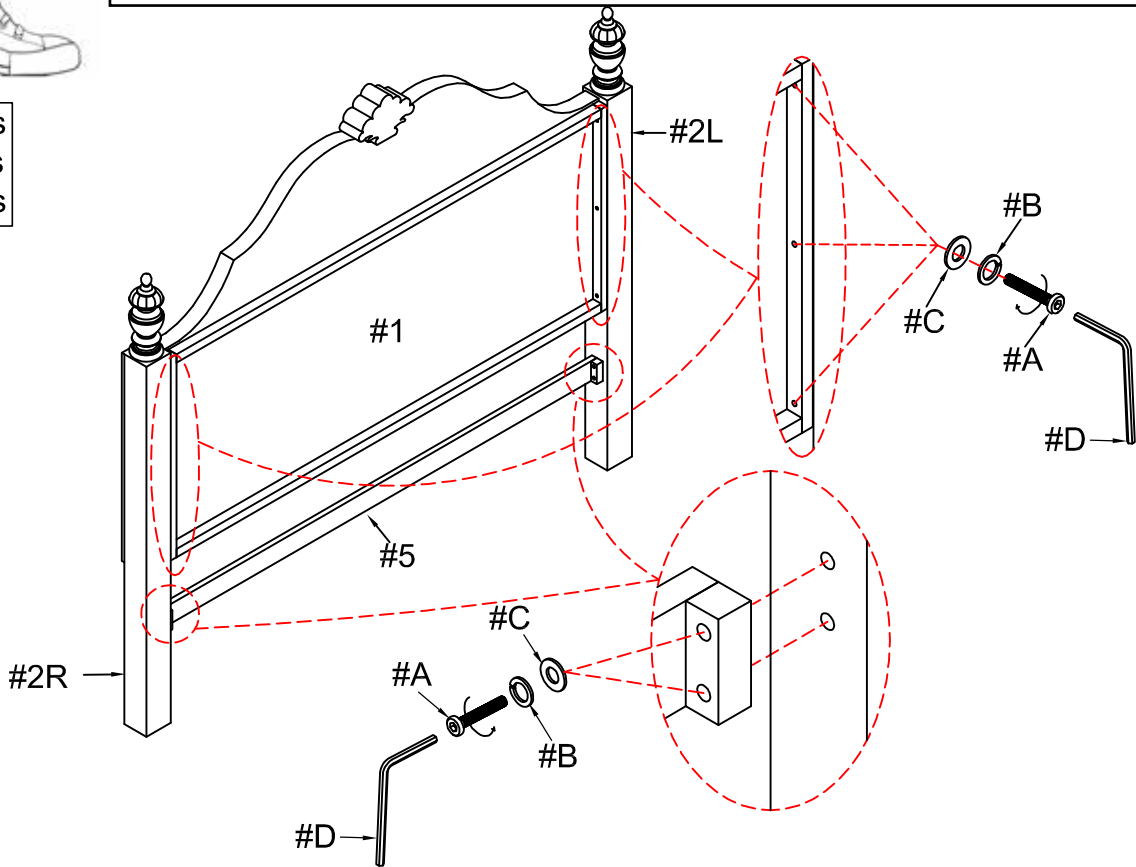

Attach threaded pins (#F) to the holes of the headboard (#1) and footboard (#3). Align the side rails (#4) to the threaded pins (#F) that are attached to headboard (#1) and footboard (#3). Secure with hex nut (#G).

F x 8pcs
G x 8pcs

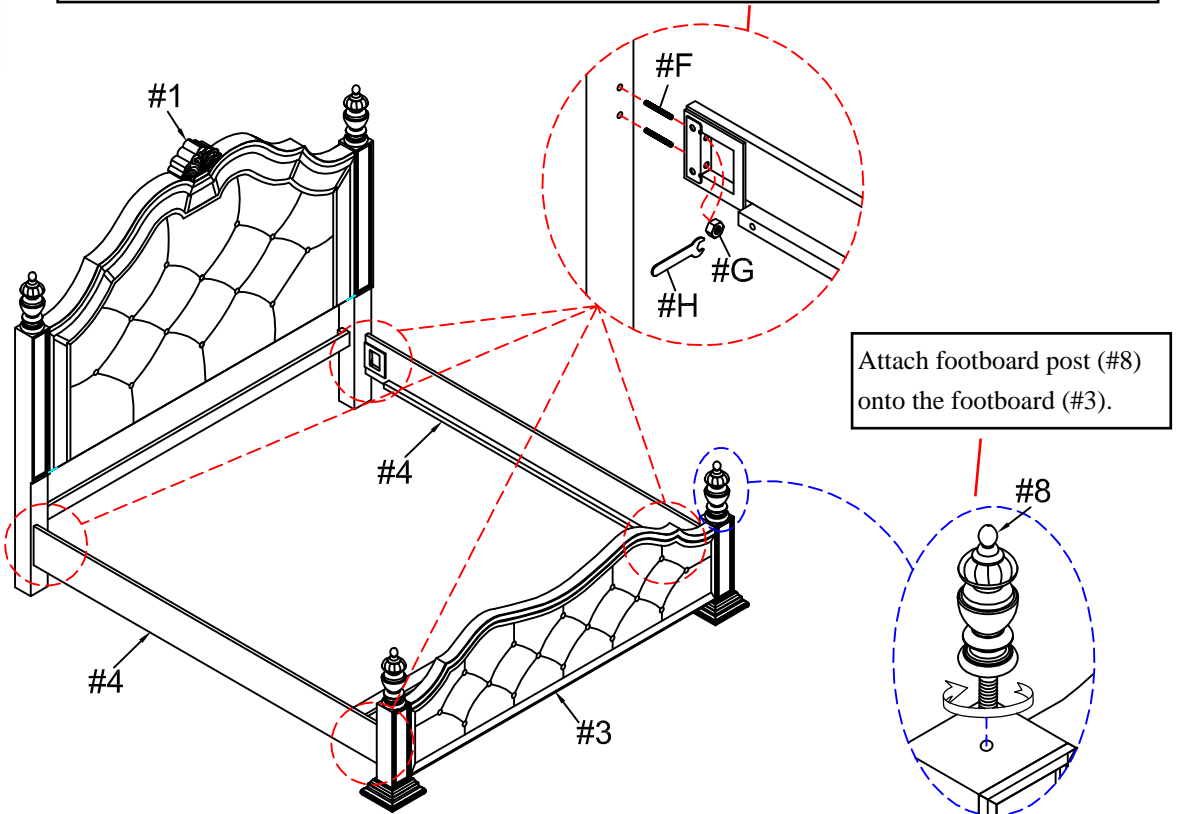

Attach footboard post (#8) onto the footboard (#3).

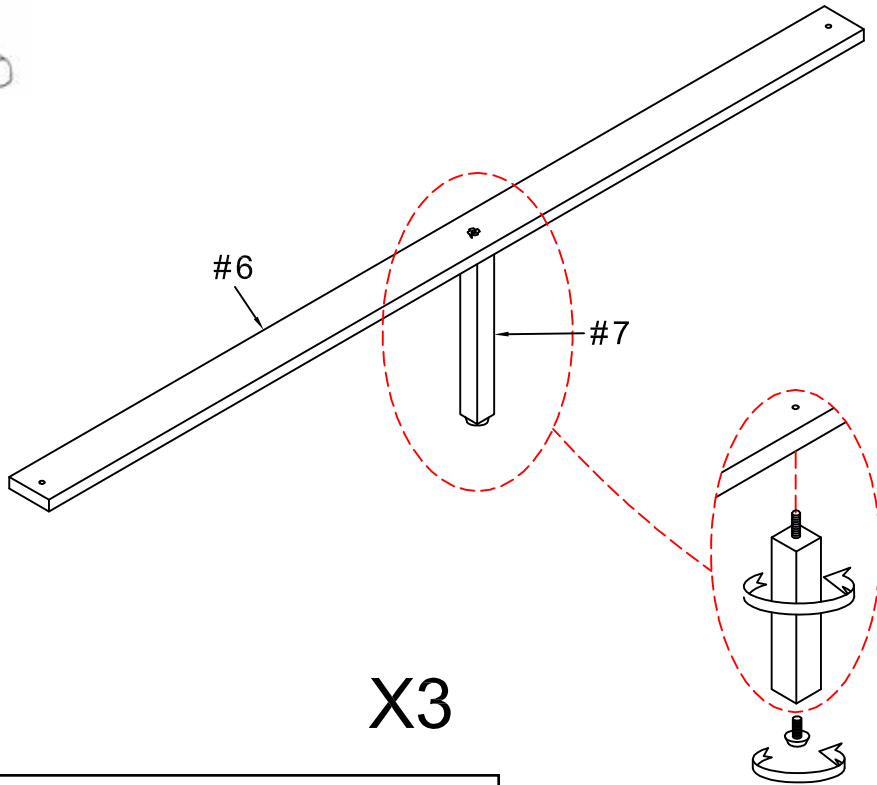

X3

Attach support legs (#7) to each slats (#6). Adjust adjustable foot on the support legs (#7) according to ground level.



Align slats (#6) to the side rails (#4), then secure with screws (#E).

#E x 6pcs

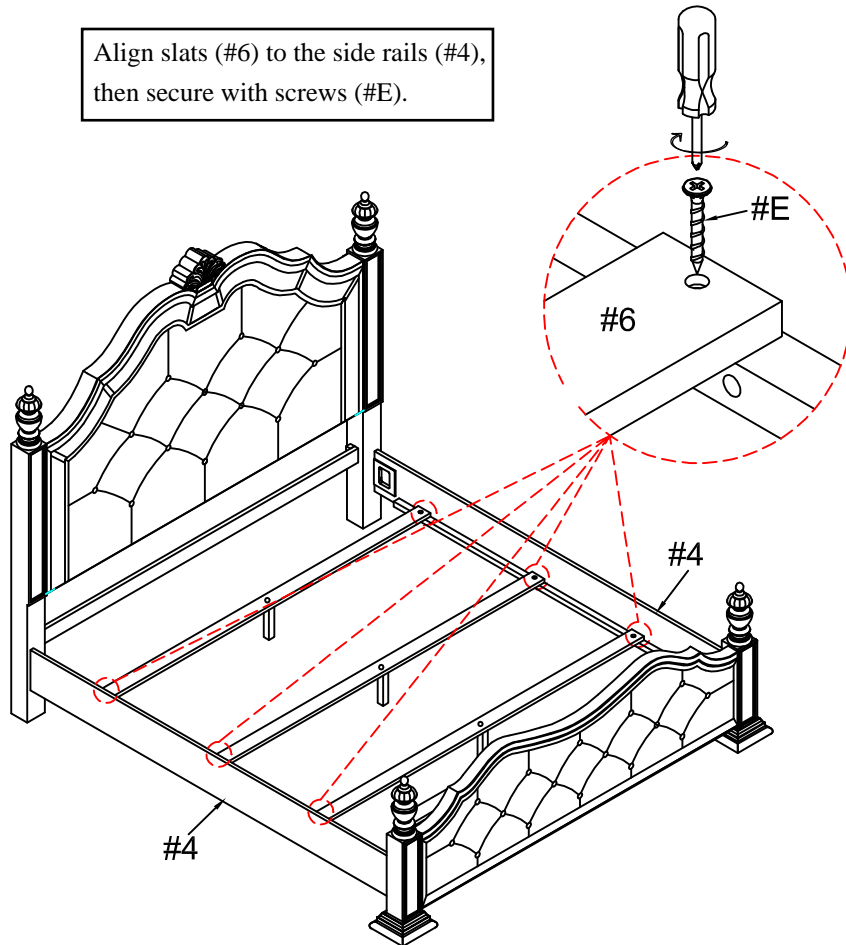

Assembly Instructions

For more information contact our team

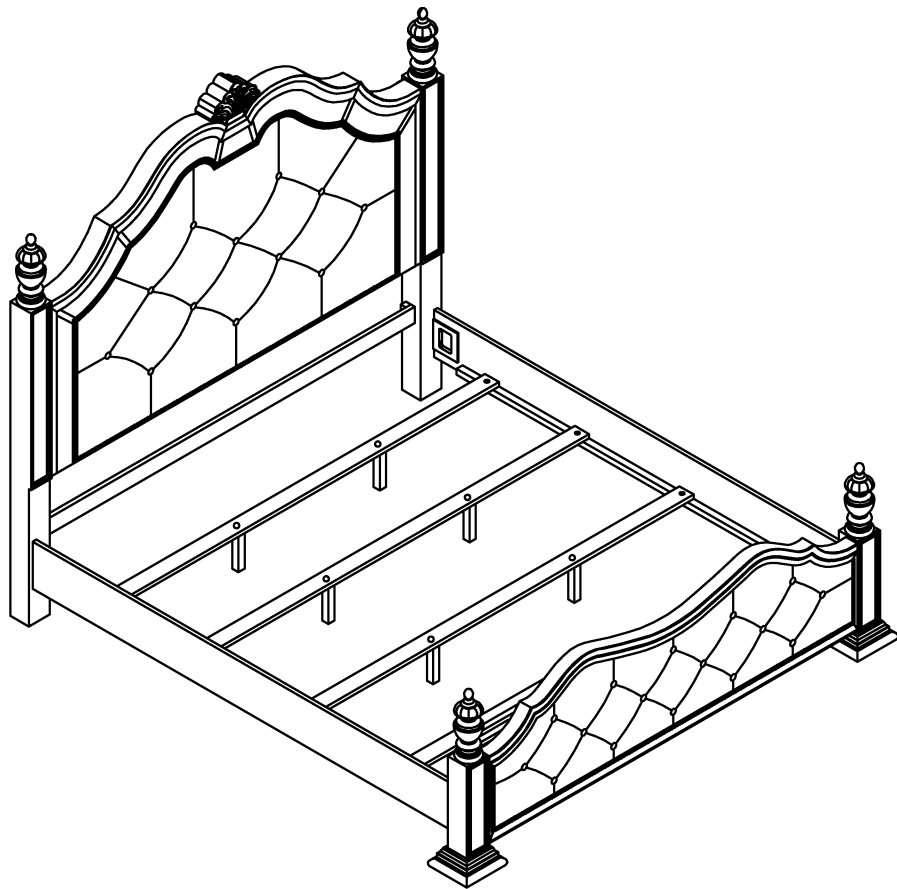

ASSEMBLY RATING

The Assembly Rating is a 5-point system that shows the degree of effort needed in assembling a specific product (with 1 being easy and 5 being difficult). For some products, two persons are recommended.

EASY



DIFFICULT

Tools Required For Assembly:

Allen Wrench

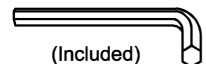

(Included)

Wrench

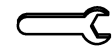

(Included)

Phillips Screwdriver



(Not Included)



2 PERSONS RECOMMENDED

ASSEMBLY & CARE ADVICE

FOR YOUR FURNITURE TO LAST, CORRECT ASSEMBLY AND PROPER MAINTENANCE ARE NECESSARY. PLEASE FOLLOW THE INFORMATION PROVIDED BELOW TO FULLY ENJOY YOUR FURNITURE.

BASIC ASSEMBLY TECHNIQUES

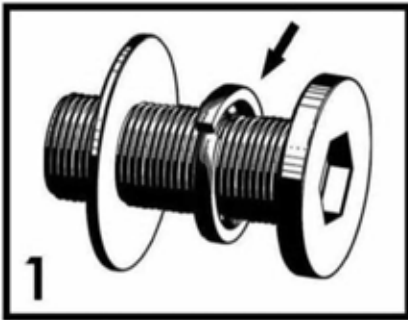

When lock or spring washer is used in an assembly, please make sure the lock or spring washer is placed between the larger flat washer and the head of the screw or bolt.



Position each part correctly and insert screws or bolts into their respective holes by hand tighten or using the proper hand tool. Only tighten when step is completed or when instructed to do so.

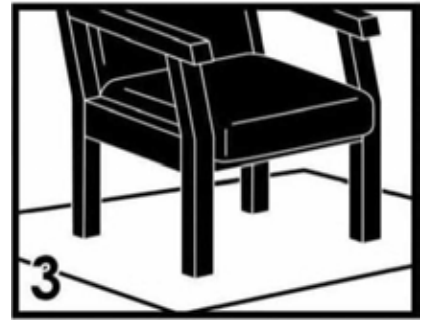

Use cardboard or carpet area when assembling furniture to prevent scratches. Make sure the furniture rests on a flat and level surface with each leg evenly touching the floor.

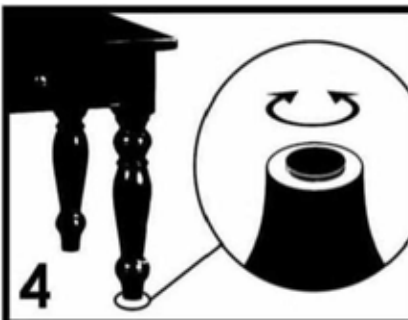

Some furniture comes with height adjustment knobs underneath each leg. To lower or to raise each leg, you need to turn clockwise or counterclockwise, respectively.

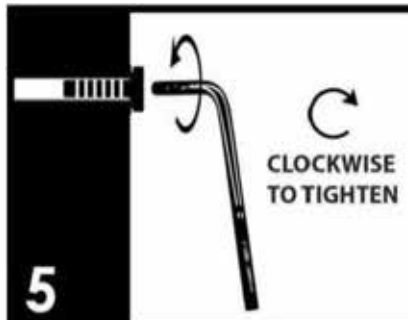

Make sure all parts are properly aligned, then use the appropriate hand tool to completely tighten the bolts or screws. Do not use power tools and do not overtighten.

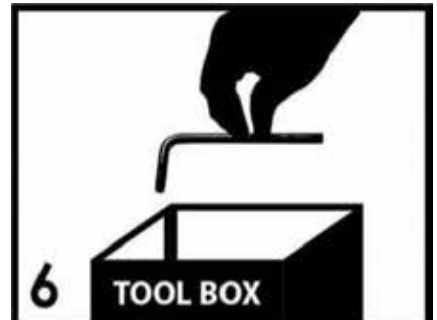

Save the instructions and store the Allen wrench or any supplied tool for later maintenance. After two weeks, check and tighten any loose hardware and repeat again every six months thereafter.

IT IS THE USER'S RESPONSIBILITY TO MAINTAIN THE FURNITURE. THE HARDWARE MAY LOOSEN OVER TIME AND MAY CAUSE THE FURNITURE TO BE WOBBLY AND UNABLE TO SUPPORT ITS INTENDED WEIGHT CAPACITY. THIS MAY LEAD TO COLLAPSE AND MAY CAUSE SERIOUS INJURY.

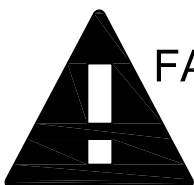

FAILURE TO FOLLOW THE GUIDELINES ABOVE MAY RESULT IN INJURY AND/OR PROPERTY DAMAGE.



Before you begin, please read Page 2 of "Assembly and Care Advice".

And remember, do not tighten until each step is completed or instructed.

Parts List

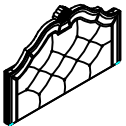

#1 x 1pc
Headboard Panel

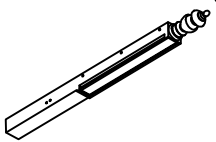

#2 x 2pcs
HB Leg (L&R)

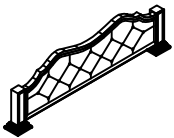

#3 x 1pc
Footboard

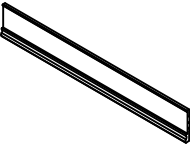

#4 x 2pcs
Side Rail



#5 x 1pc
Headboard Support

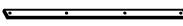

#6 x 4pcs
Bed Slat

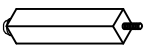

#7 x 8pcs $\text{Ø}1/4"$
Support Leg 30x30x165mm



#8 x 2pcs
Footboard Post

Hardware List



#A x 10pcs
Bolt $\text{Ø}5/16"$ x 2"



#B x 10pcs
Lock Washer $\text{Ø}5/16"$

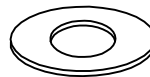

#C x 10pcs
Flat Washer $\text{Ø}5/16"$



#D x 1pc
Allen Key 4mm

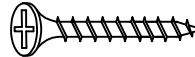

#E x 8pcs
Screw #4 x 1-3/16"



#F x 8pcs
Threaded Pins $\text{Ø}5/16"$ x3-1/2"

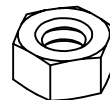

#G x 8pcs
Hex Nut $\text{Ø}5/16"$

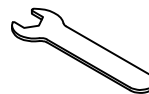

#H x 1pc
Wrench 14mm



Prepare 10 bolts assembly by inserting lock washer (#B), then flat washer (#C) onto bolts (#A). Align headboard (#1) and headboard support (#5) to the holes of the headboard legs (#2R/L), then secure with bolts (#A).

A x 10pcs
B x 10pcs
C x 10pcs

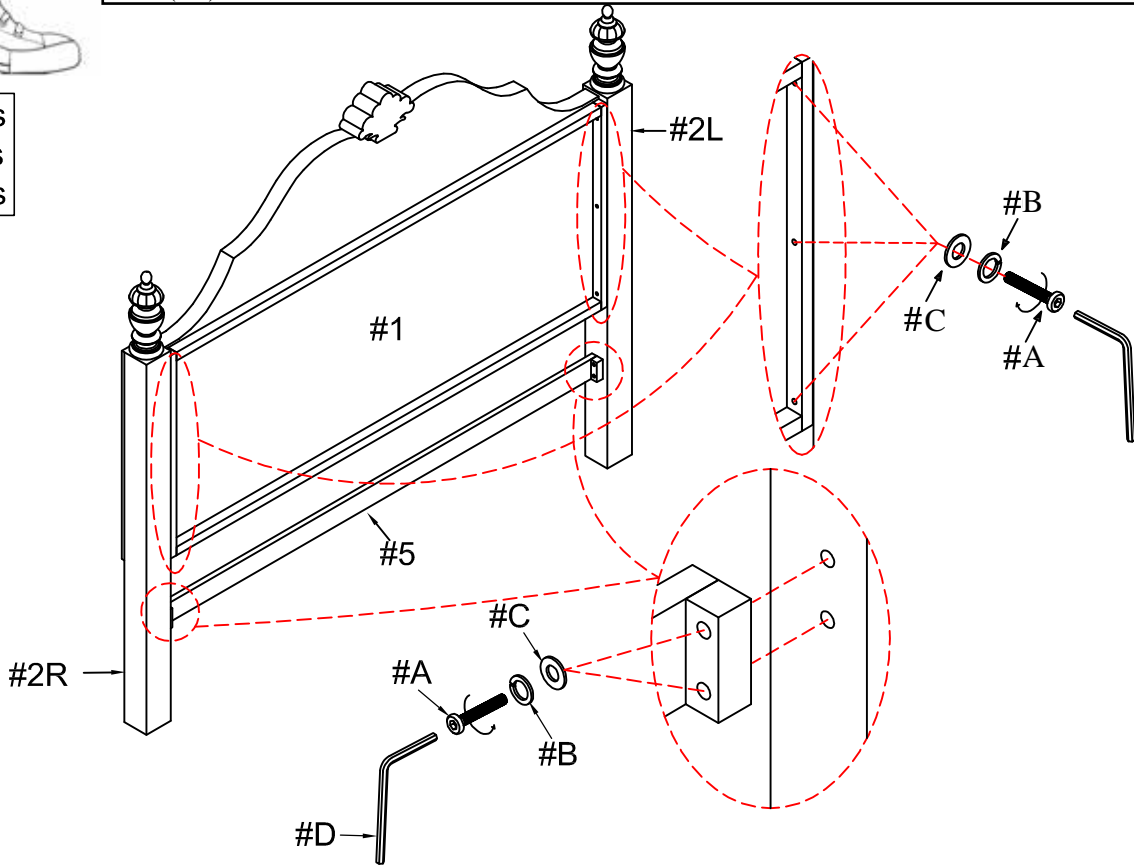

Attach threaded pins (#F) to the holes of the headboard (#1) and footboard (#3). Align the side rails (#4) to the threaded pins (#F) that are attached to headboard (#1) and footboard (#3). Secure with hex nut (#G).

F x 8pcs
G x 8pcs

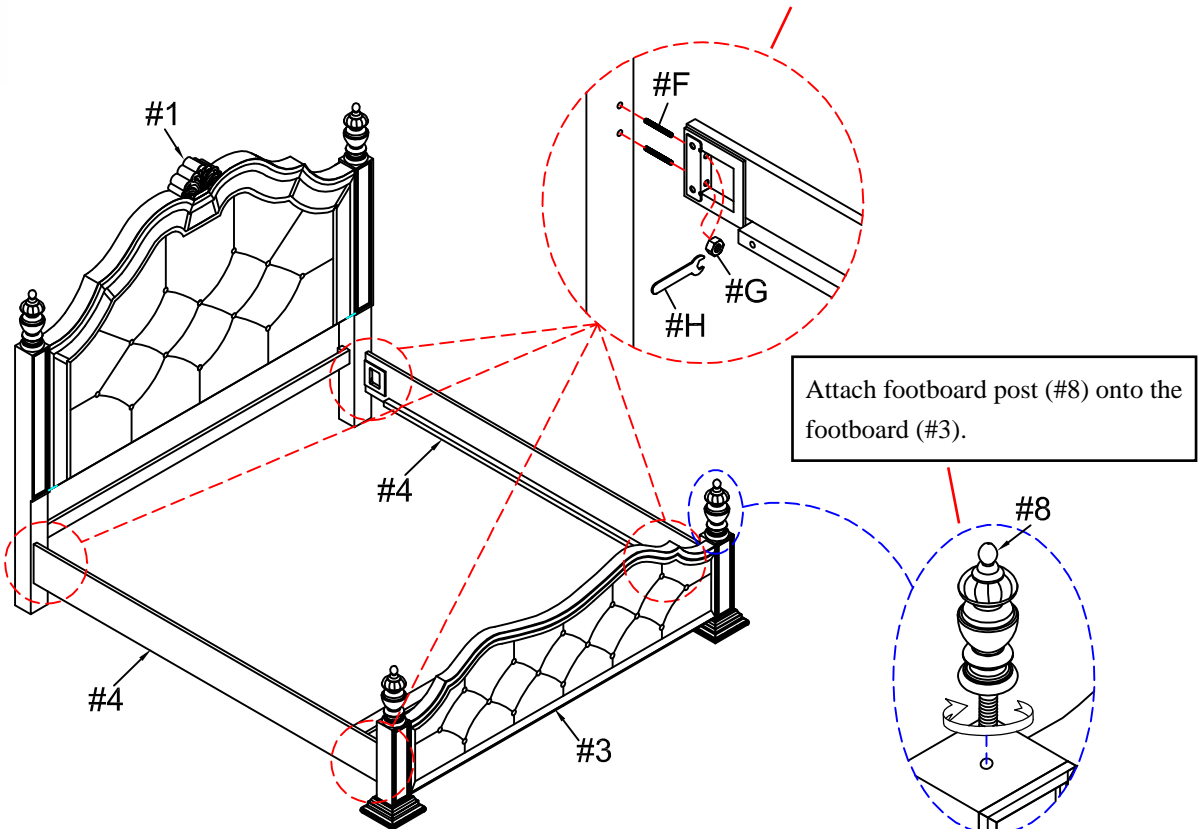

Attach footboard post (#8) onto the footboard (#3).



#3

X4

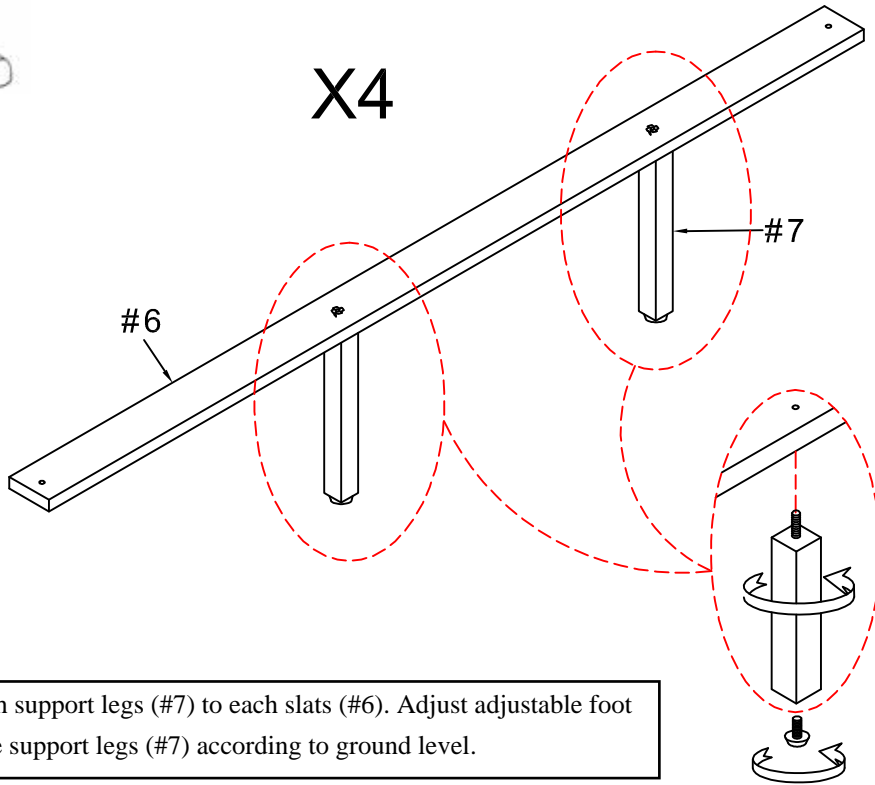

Attach support legs (#7) to each slats (#6). Adjust adjustable foot on the support legs (#7) according to ground level.



#4

Align slats (#6) to the side rails (#4), then secure with screws (#E).

#E x 8pcs

