

STUDY SET

TIPS

- 1 Please review all parts and hardware before disposing of any packaging.
- 2 Check to be sure that all parts and hardware before you start to assembly.
- 3 Before beginning assembly, separate each type of screw.
- 4 Using a screw that is too long will cause damage.
- 5 Carefully study the screw diagrams below.
- 6 You may receive extra hardware with your unit.
- 7 Place all parts on a clean and smooth surface to avoid the parts from being scratched.
- 8 Keep the product away from heat and humidity.
- 9 Light blue stains and natural wood knots on the product are not considered defects.



PART LIST

A Table Top
1Pc



B Shelf
1Pc



C Supporter
2Pcs



D Table Leg (Big)(Left)
1Pc



E Table Leg (Big)(Right)
1Pc



F Table Leg (Small)(Left)
1Pc



G Table Leg (Small)(Right)
1Pc



H Chair back
1Pc



I Chair leg-L
1Pc

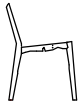

J Chair leg-R
1Pc

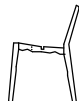

K Cushion seat
1Pc



L Corner Block
1Pc

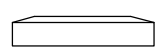

STUDY SET

HARDWARE LIST

M JCBC Screw M6 x 25mm
6Pcs

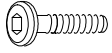

N JCBC Screw M6 x 35mm
10Pcs

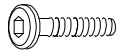

O JCBC Screw M6 x 50mm
2Pcs

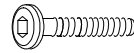

P Wood Dowel M8 x 30mm
4Pcs

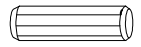

Q Allen Key M4
1Pc



R JCBC screw M6 x 70mm
6Pcs

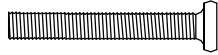

S Spring washer M6
6Pcs



T Flat washer M6 x 13 x 1.0mm
6Pcs



U Wood button
4Pcs



V JCBC/W Screw M7 x 35mm
4Pcs



IMPROPER USE :

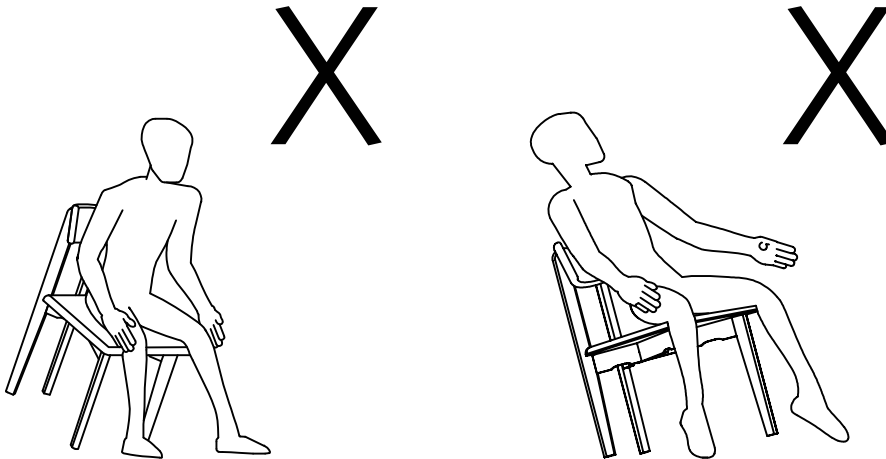

STUDY SET

ASSEMBLY INSTRUCTIONS

1 STEP 1

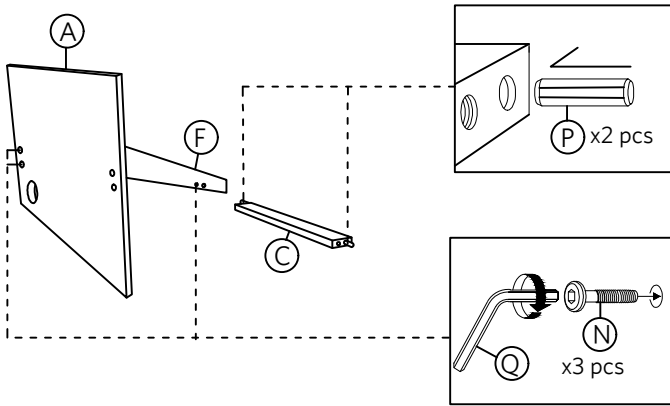

2 STEP 2

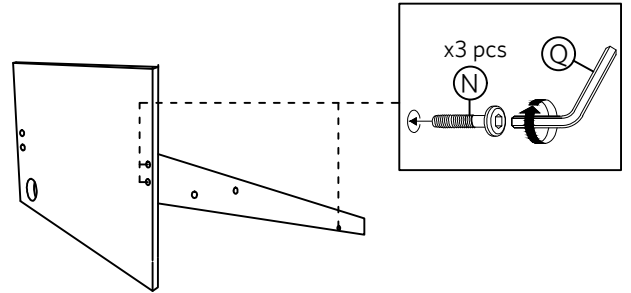

3 STEP 3

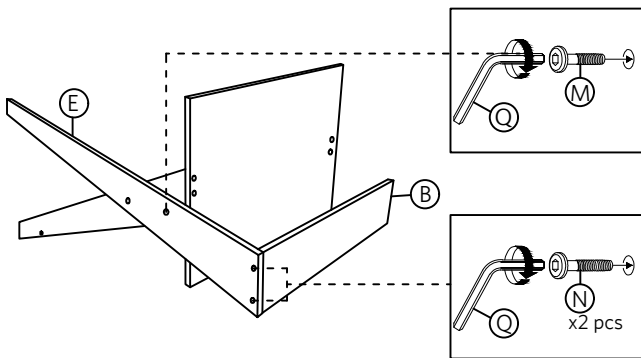

4 STEP 4

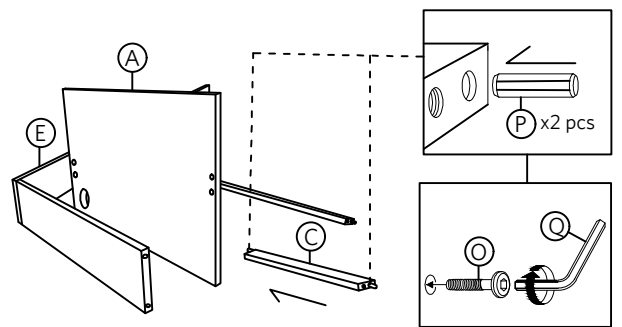

5 STEP 5

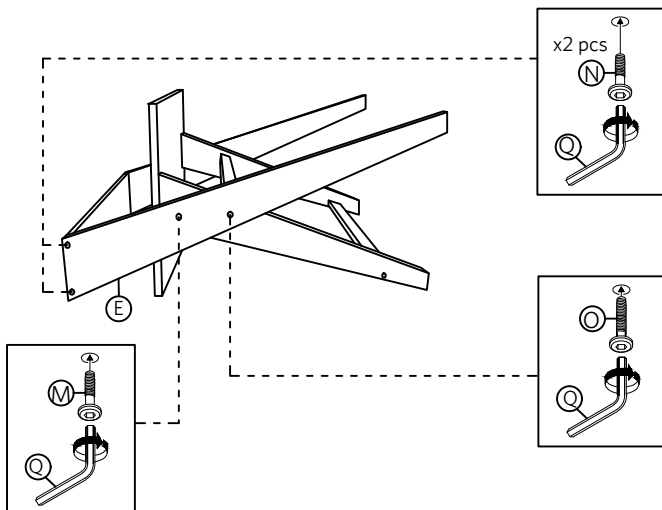

6 STEP 6



STUDY SET

ASSEMBLY INSTRUCTIONS

7 STEP 7

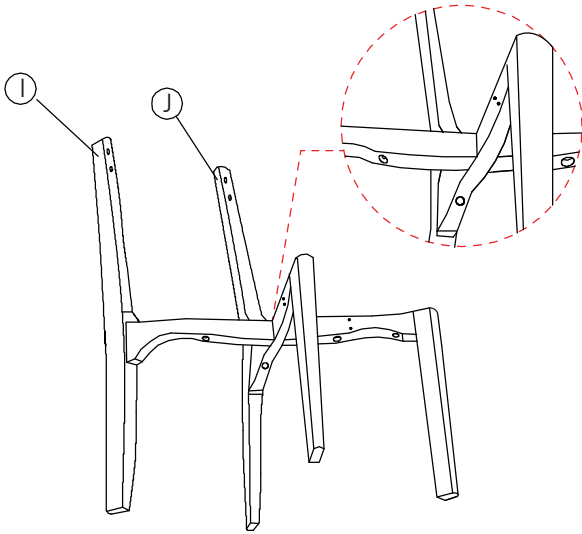

8 STEP 8

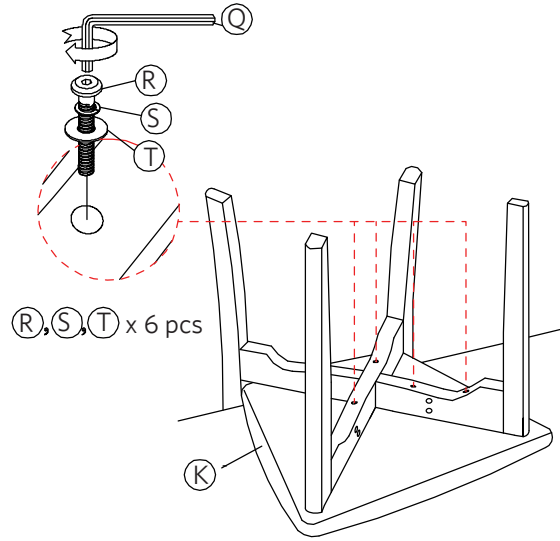

9 STEP 9

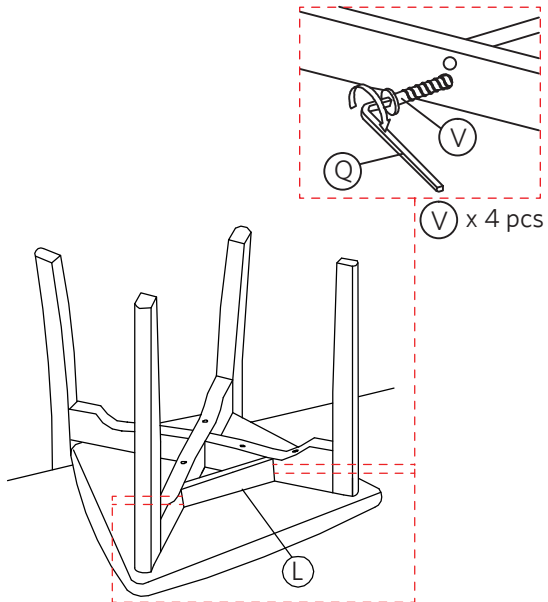

10 STEP 10

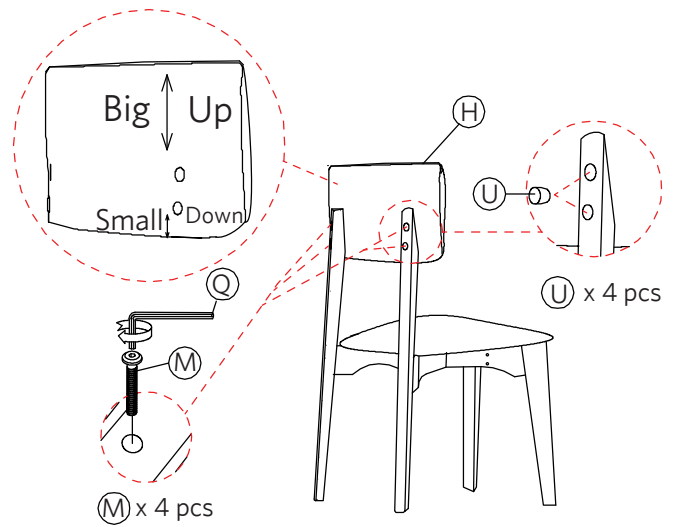

11 STEP 11

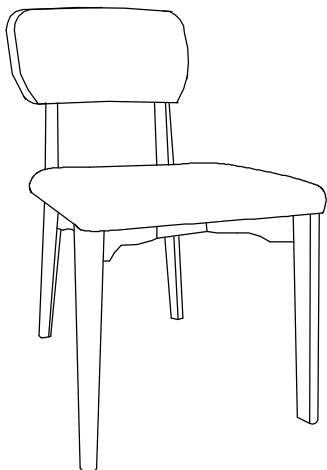

12 STEP 12

