

Recommended Maximum Weight

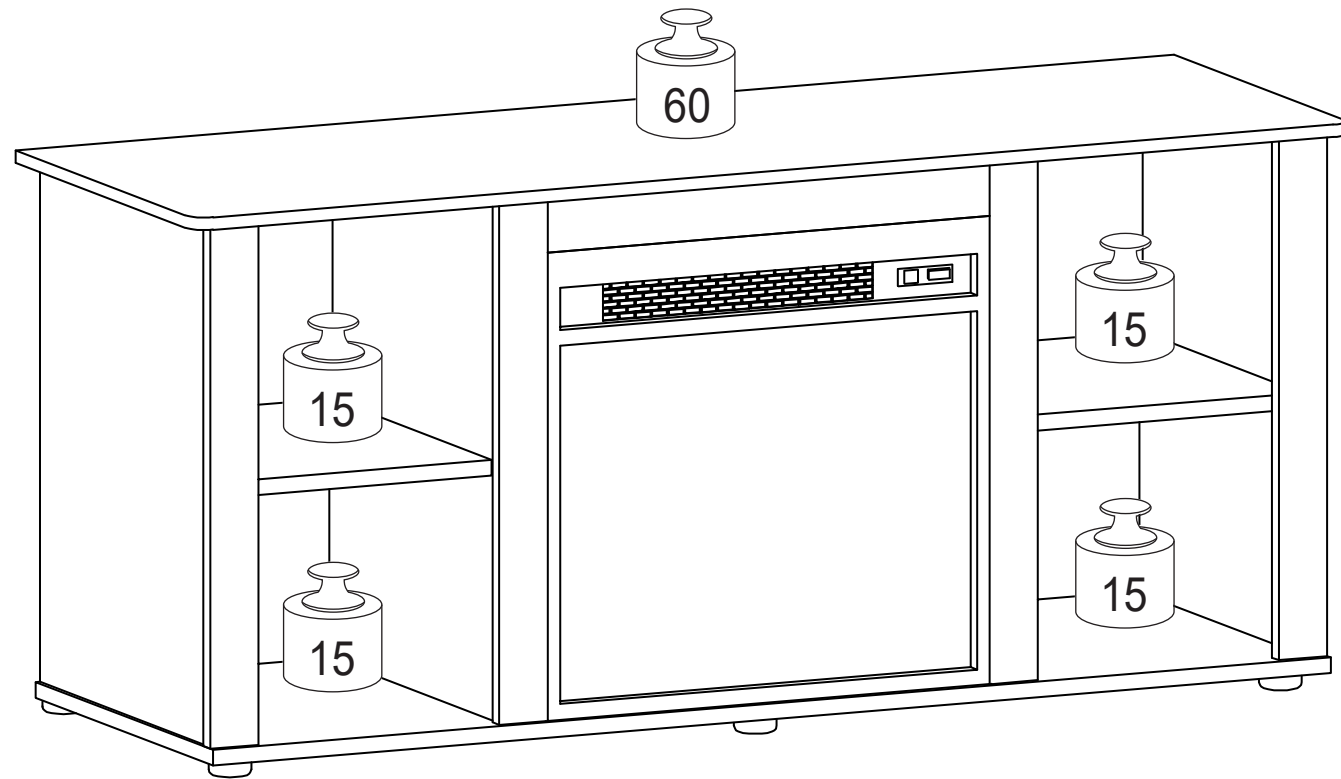

*Unit in Pound(lbs.)

WARNING:

>This unit has been designed to support the maximum loads shown. Exceeding these load limits could cause sagging, instability, product collapse, and/or serious injury.

>DO NOT allow children to climb on unit.

> Put heavier items on lower shelves.

Assembly Instruction

TV Stand with Fireplace

0 1:00

Approx. 1 Hour





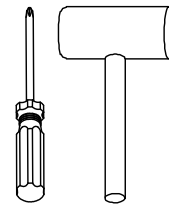



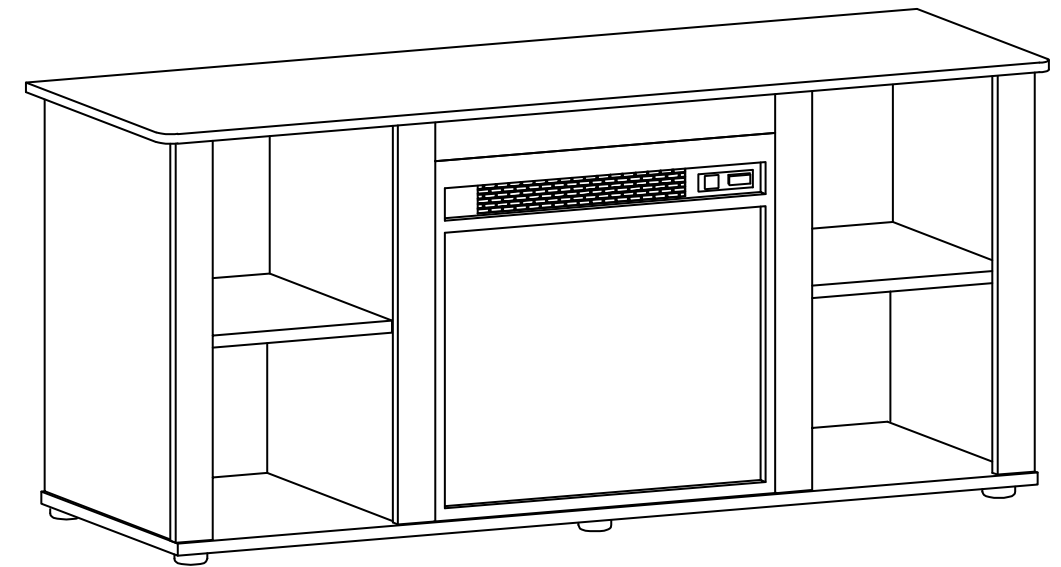



Recomm. 2 Person



Tools Required

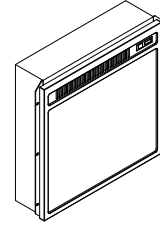

HARDWARE & PARTS LIST

NO	HARDWARE LIST	QTY
1	MINIFIX  	16pcs
2	DOWEL 	16pcs
3	CHIPBOARD SCREW 	8pcs
4	SHELF SUPPORT 	8pcs
5	L BRACKET 	2pcs
6	PLUG LEG 	6pcs
7	METAL BRACKET 	1pc
8	SCREW 	11pcs
9	POWER PIN 	36pcs
10	FIREPLACE 	1pc

NO	PARTS LIST	QTY
A1	LEFT SIDE PANEL	1pc
A2	RIGHT CENTER PANEL	1pc
B1	LEFT CENTER PANEL	1pc
B2	RIGHT SIDE PANEL	1pc
C	RAIL PANEL	4pcs
D	TOP PANEL	1pc
E	COVER PANEL	1pc
F	BOTTOM PANEL	1pc
G	SHELF PANEL	2pcs
H	BACK PANEL	2pcs

USEFUL HINTS BEFORE YOU START:

1. Read each step carefully before starting.
2. It is important that each step is performed in correct order to avoid difficulties.
3. Identify, sort and count the parts before assembly.
4. Assemble your furniture on packaging cardboard to prevent scratch or damage.
5. Clean the product with mild cleanser using soft dampened cloth. Do not use harsh or abrasive cleanser.
6. Using incompatible hardware might cause damage to product.

STEP 15

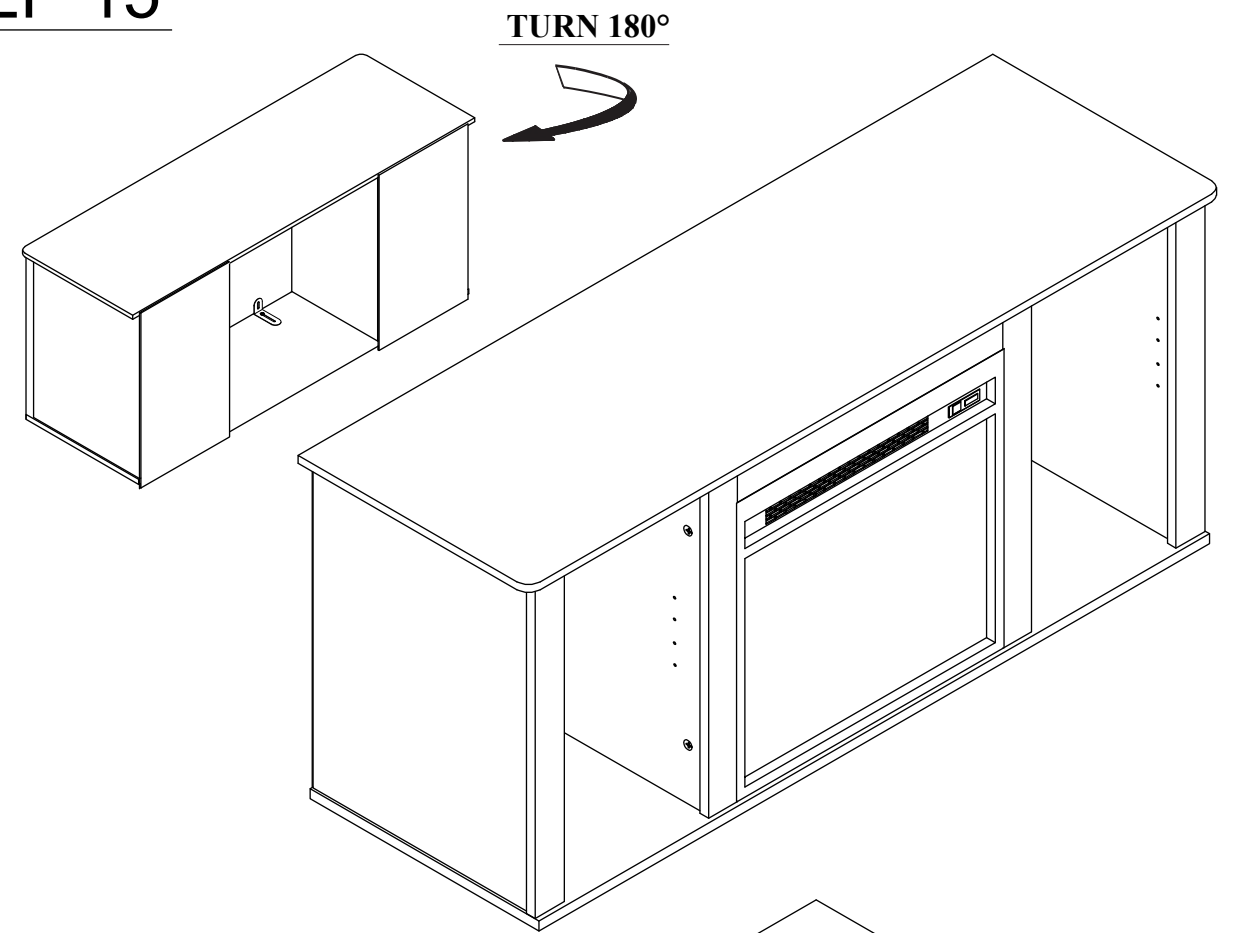

STEP 16

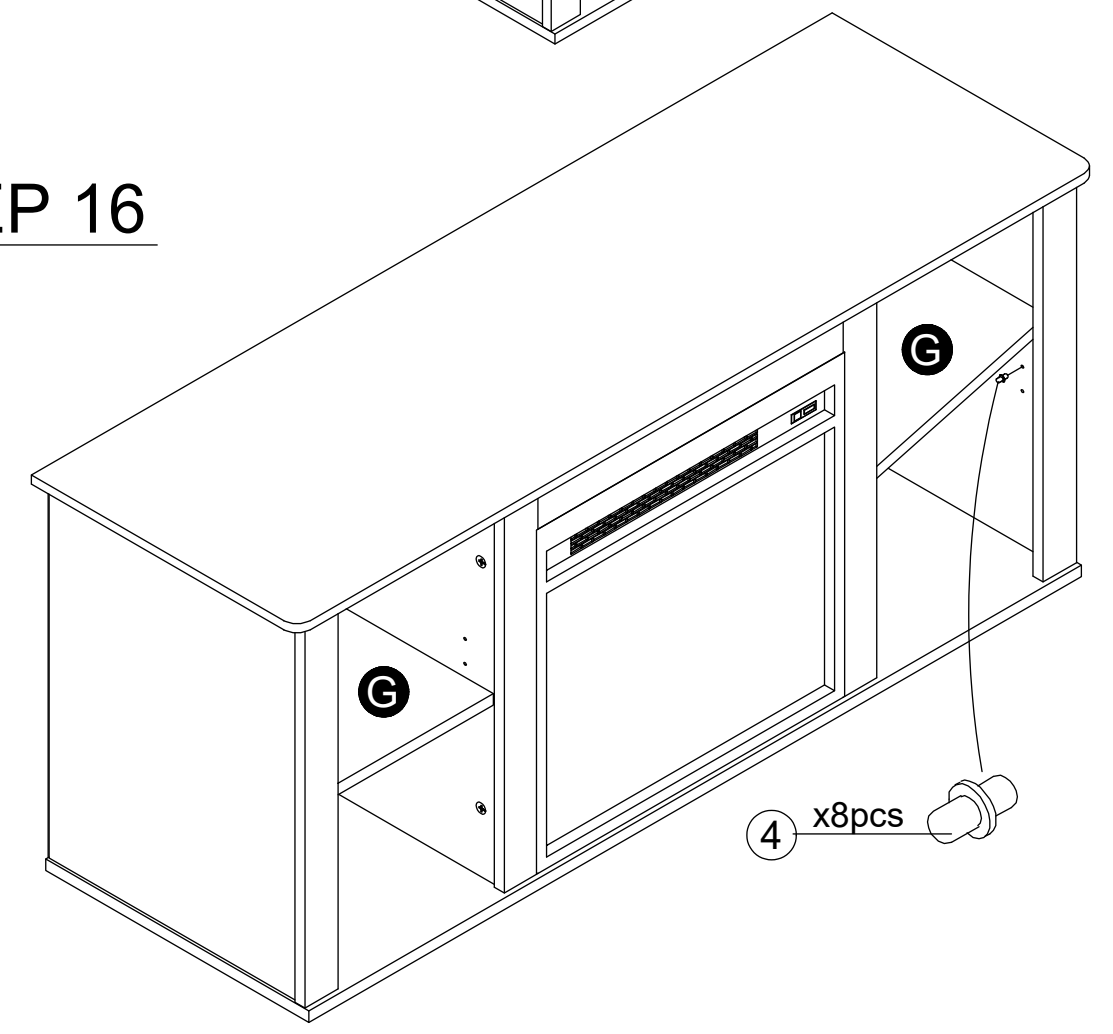

STEP 13

Fasten flange of fireplace to vertical rails(C) with screw (8). You will screw into the groove of the vertical rails(C).

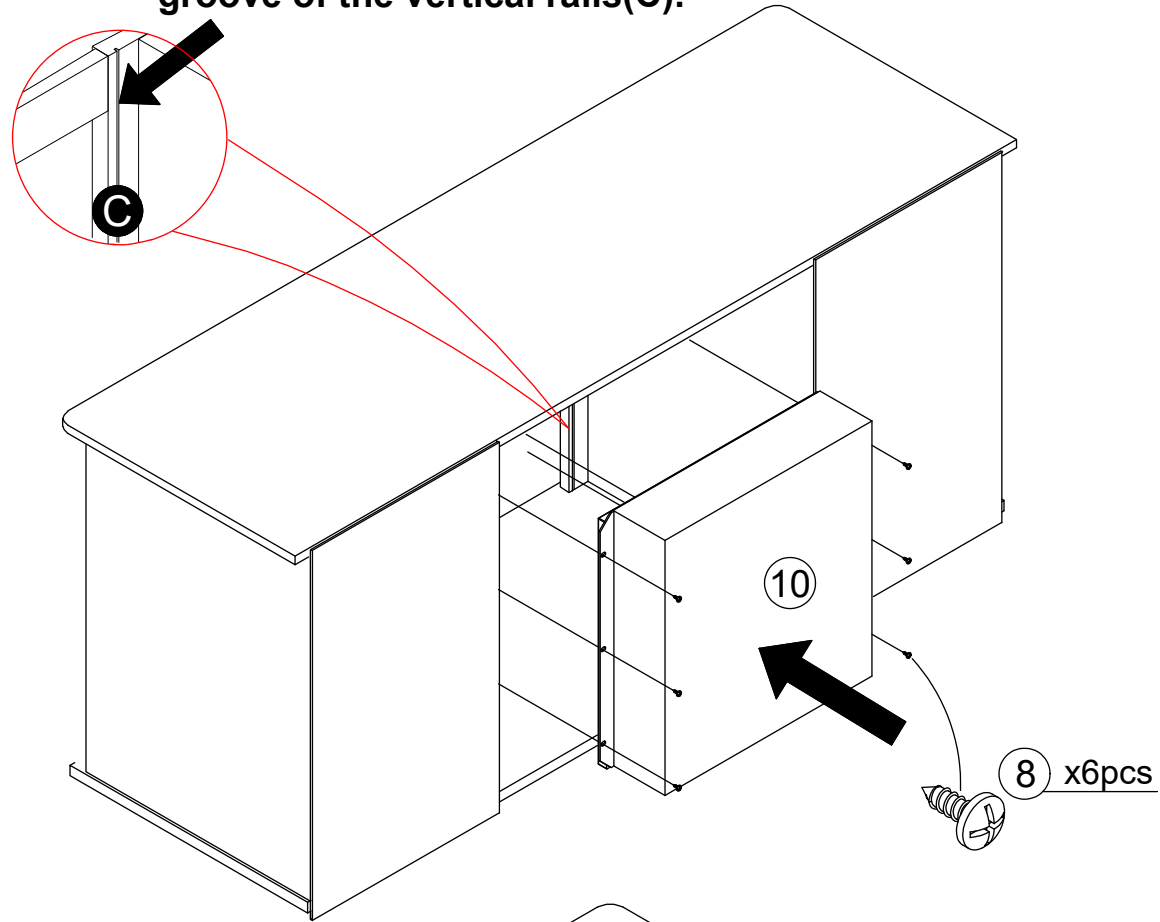

STEP 14

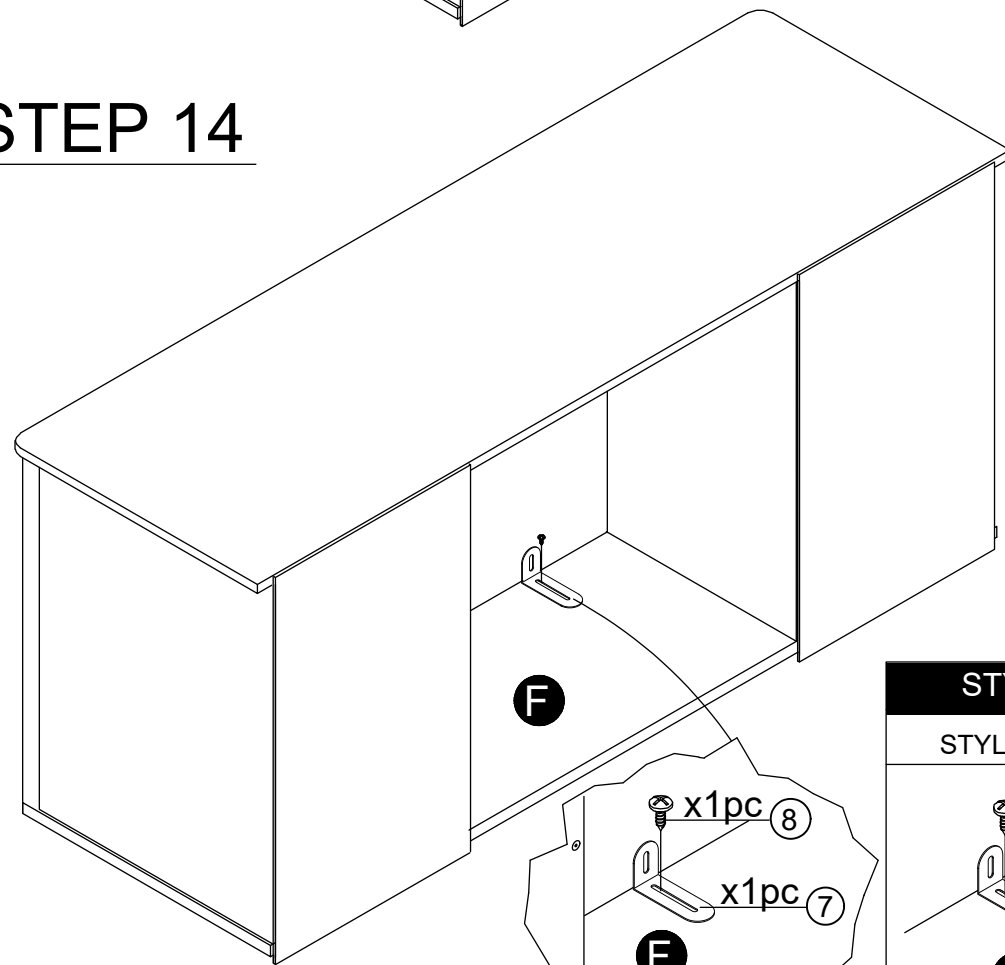

STYLE INSTALLATION	
STYLE 1	STYLE 2
 F	 F

FRONT VIEW

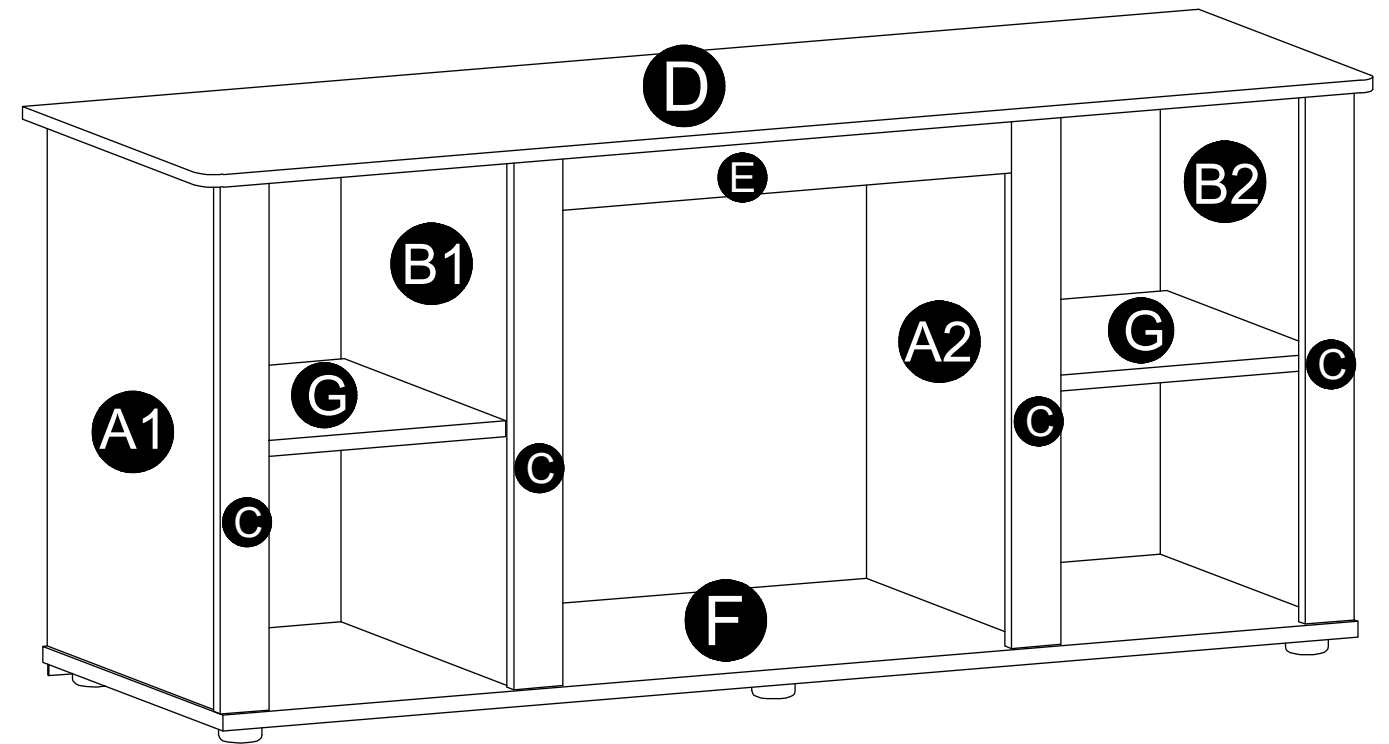

BACK VIEW

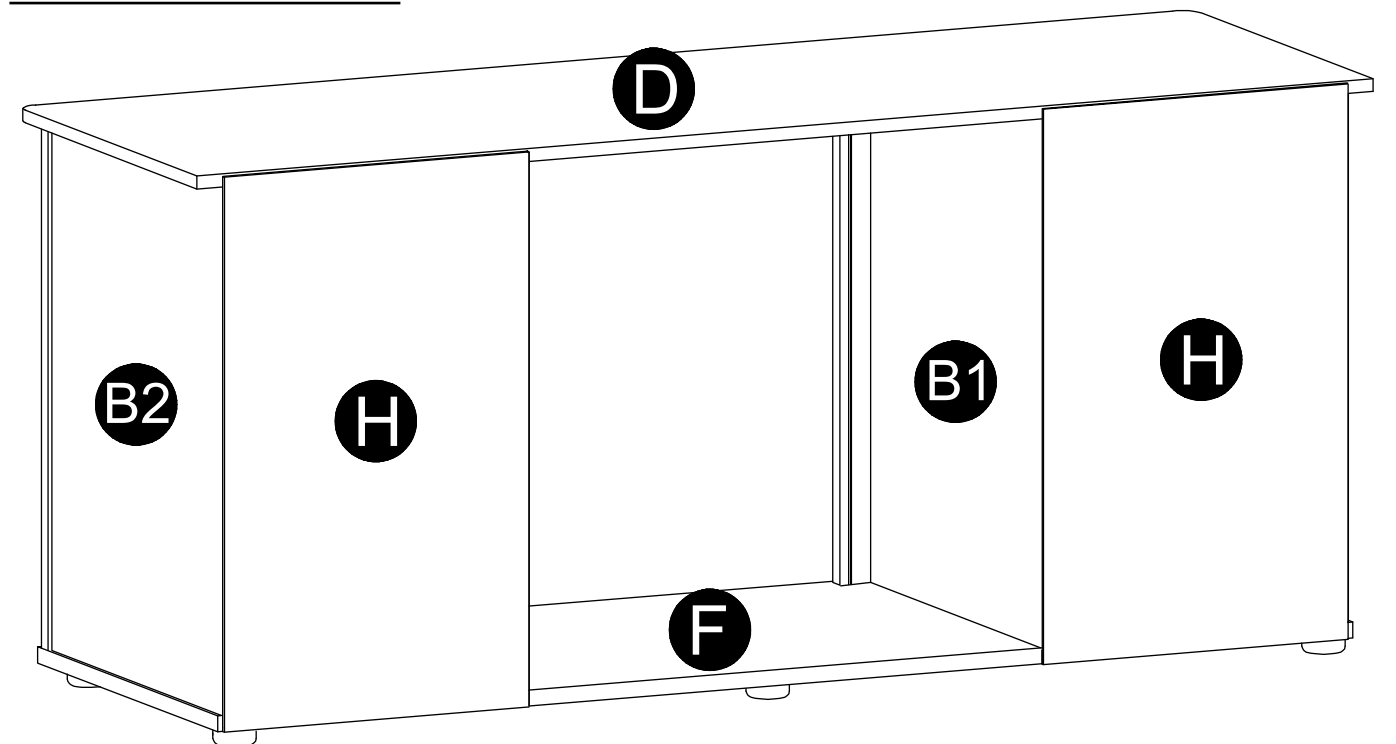

ASSEMBLY INSTRUCTIONS

BEFORE YOU BEGIN, PLEASE READ ASSEMBLY INSTRUCTIONS CAREFULLY,
FOLLOW THEM STEP BY STEP.

STEP 1

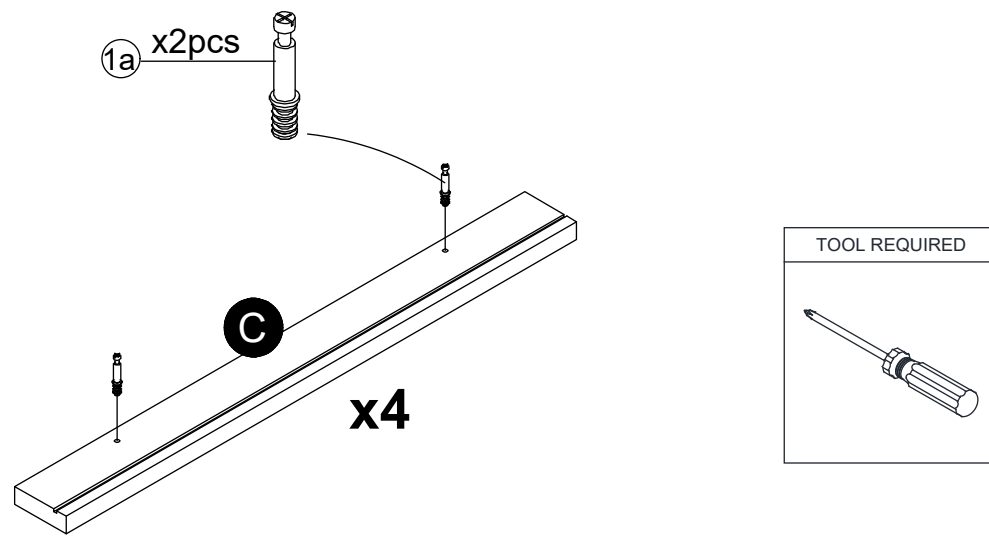

STEP 2

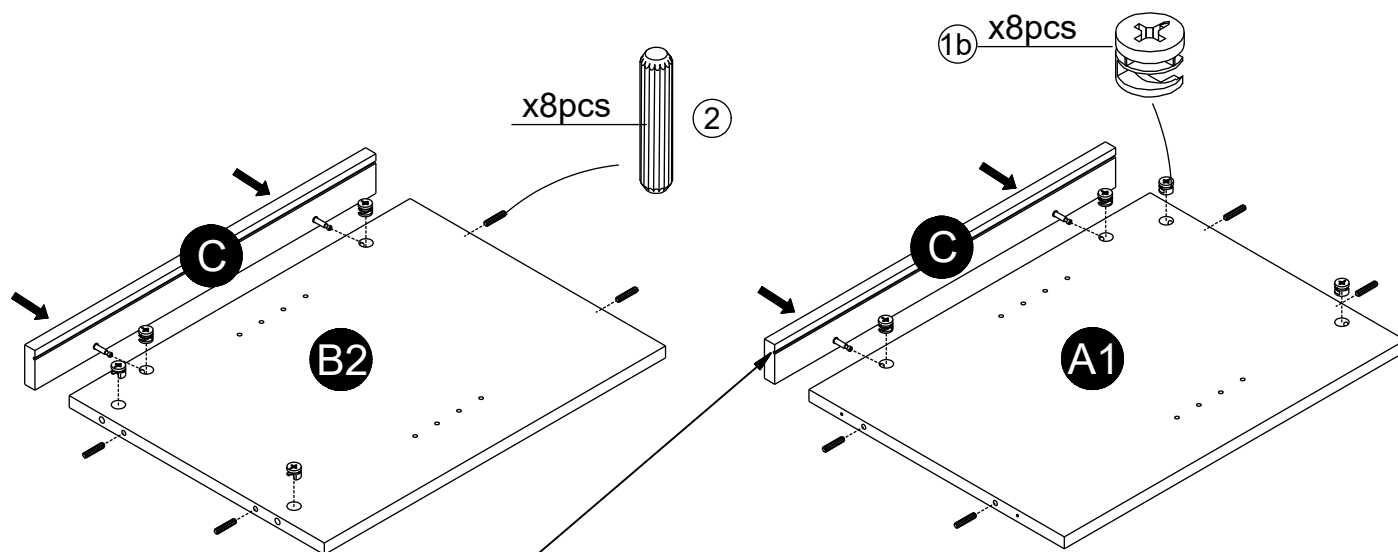
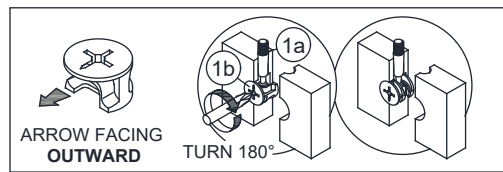

Notice: The groove is on the **UPPER** side.

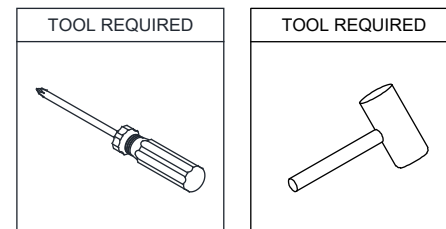

STEP 11

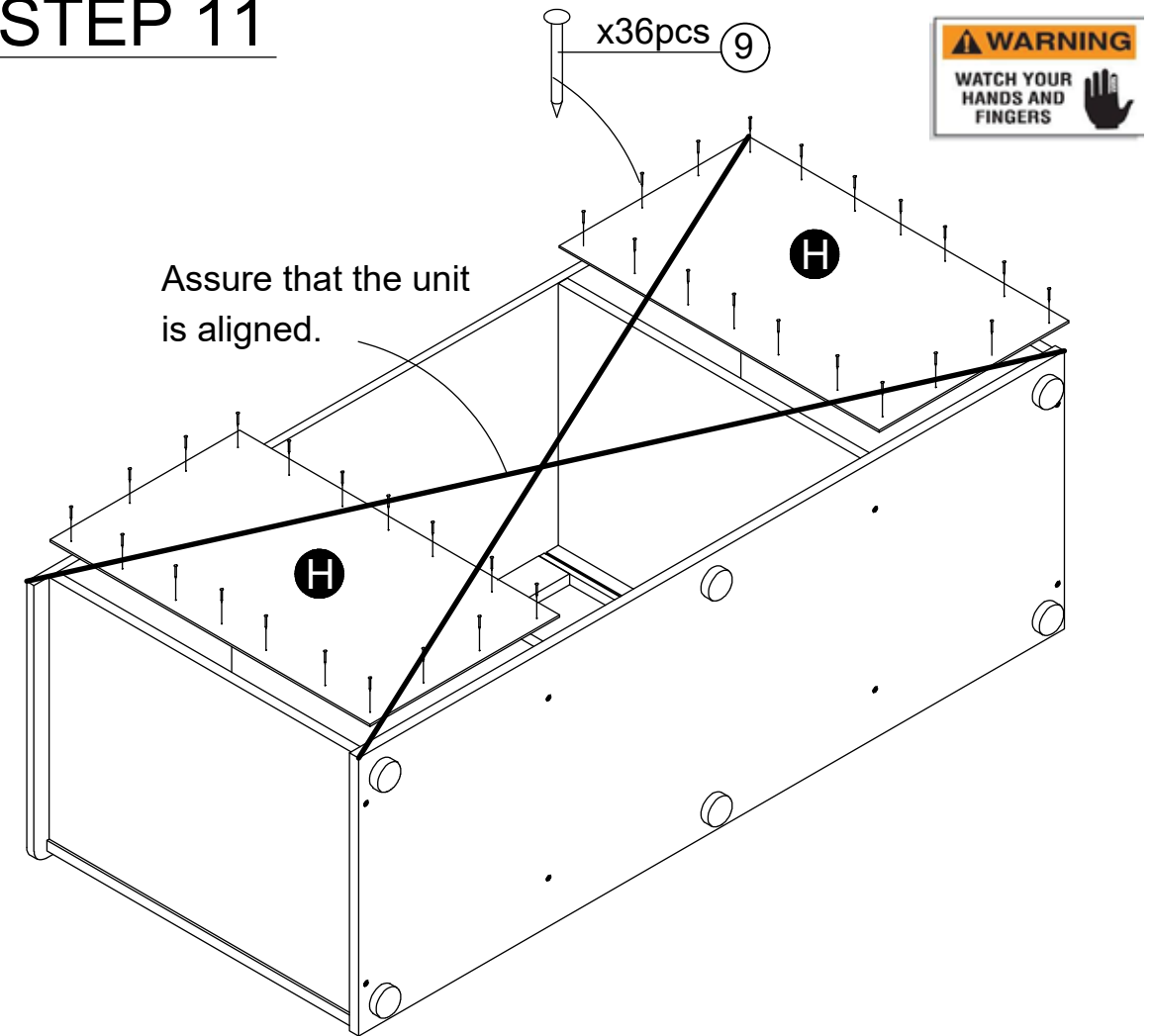

STEP 12

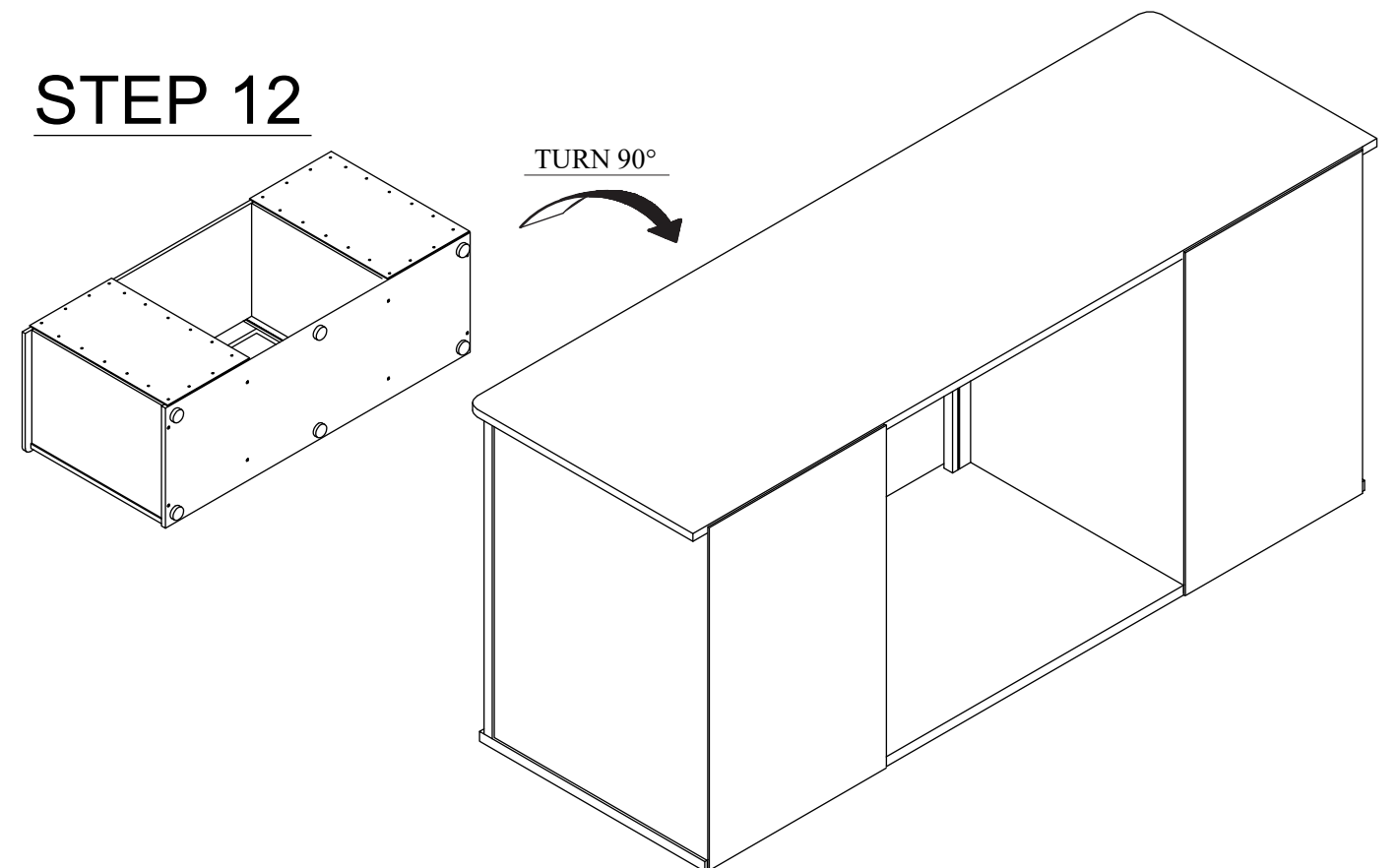

STEP 9

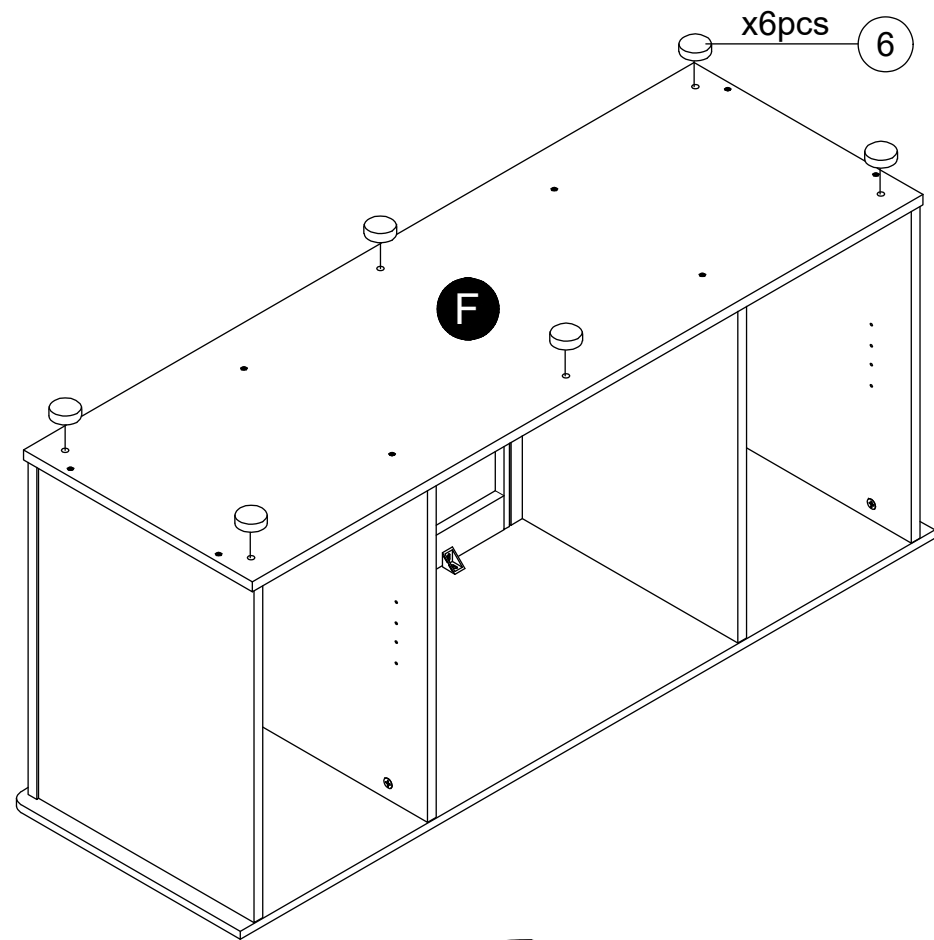

STEP 10

The direction of rotation is back up

UNFINISHED EDGE

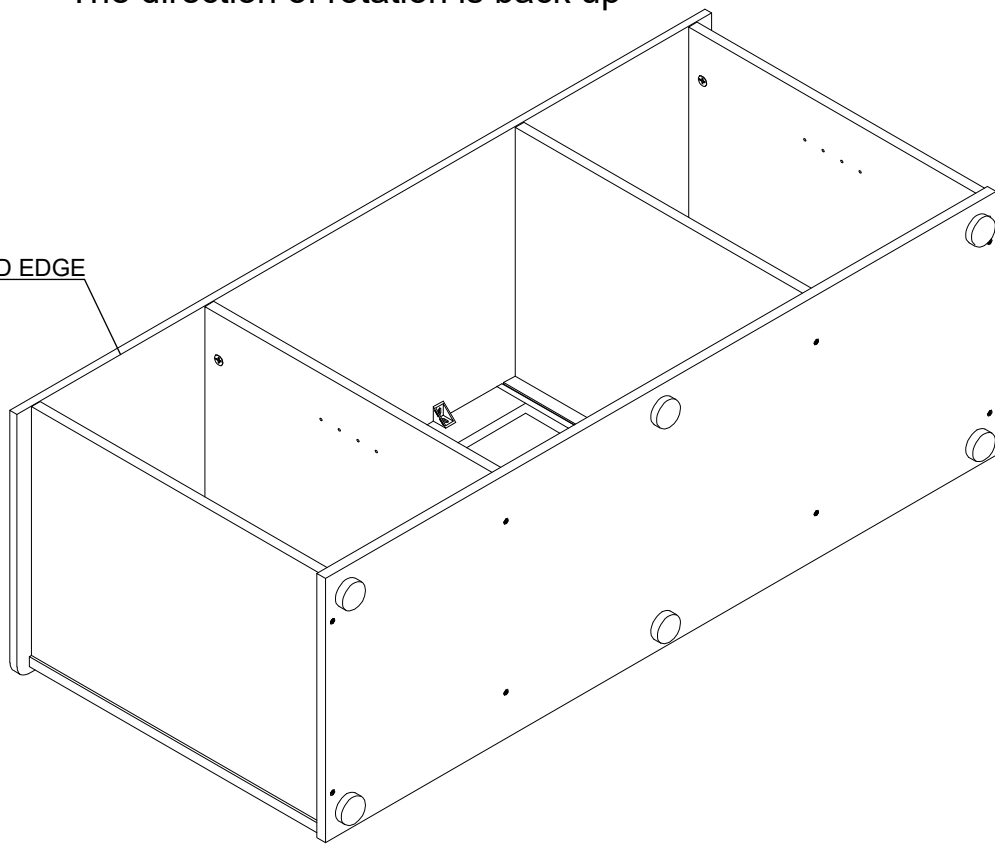

STEP 3

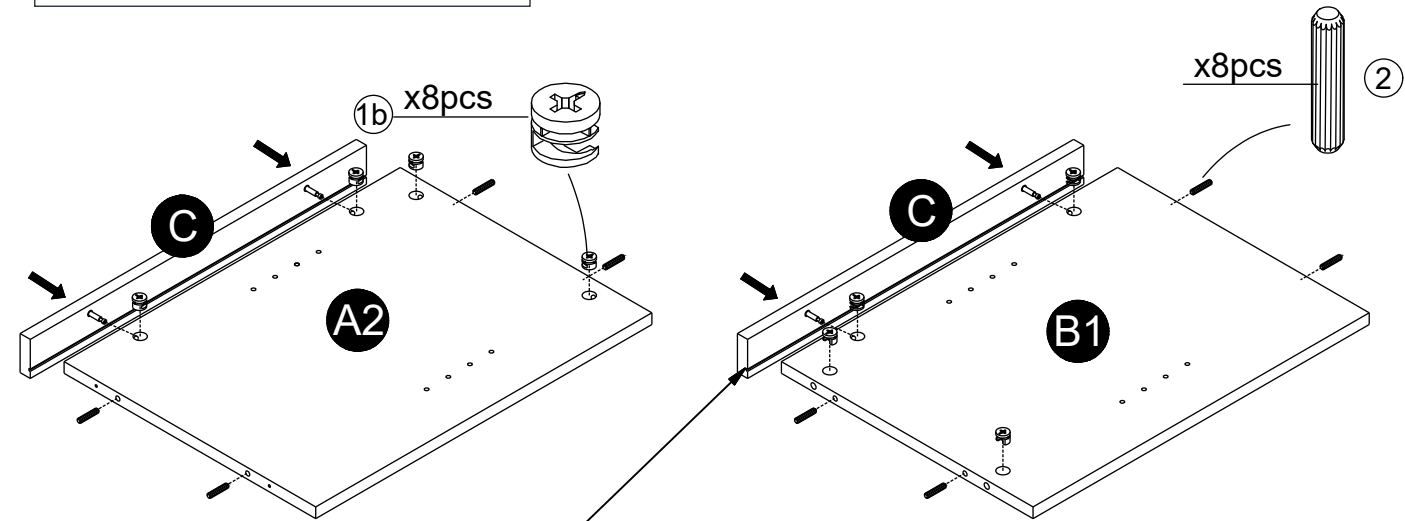
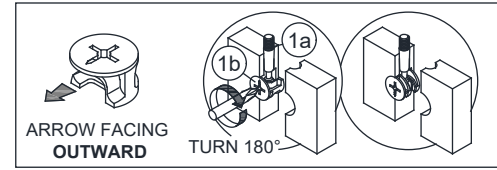

Notice: The groove is on the LOWER side.

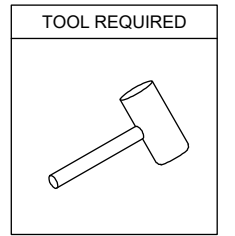
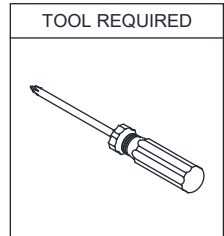

STEP 4

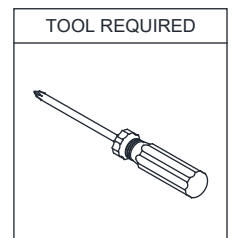
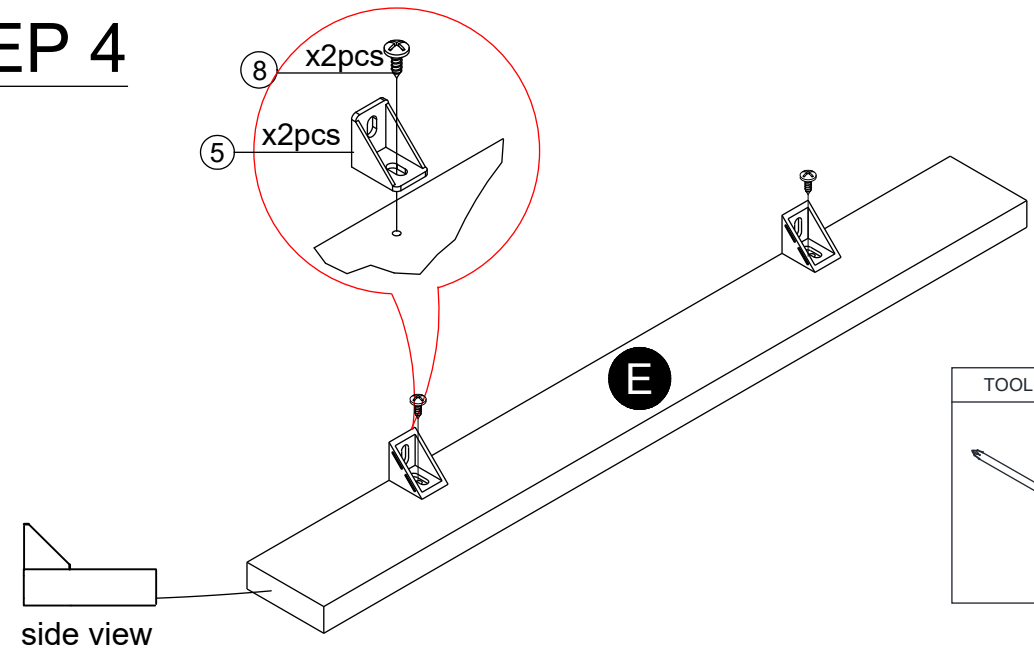

STEP 5

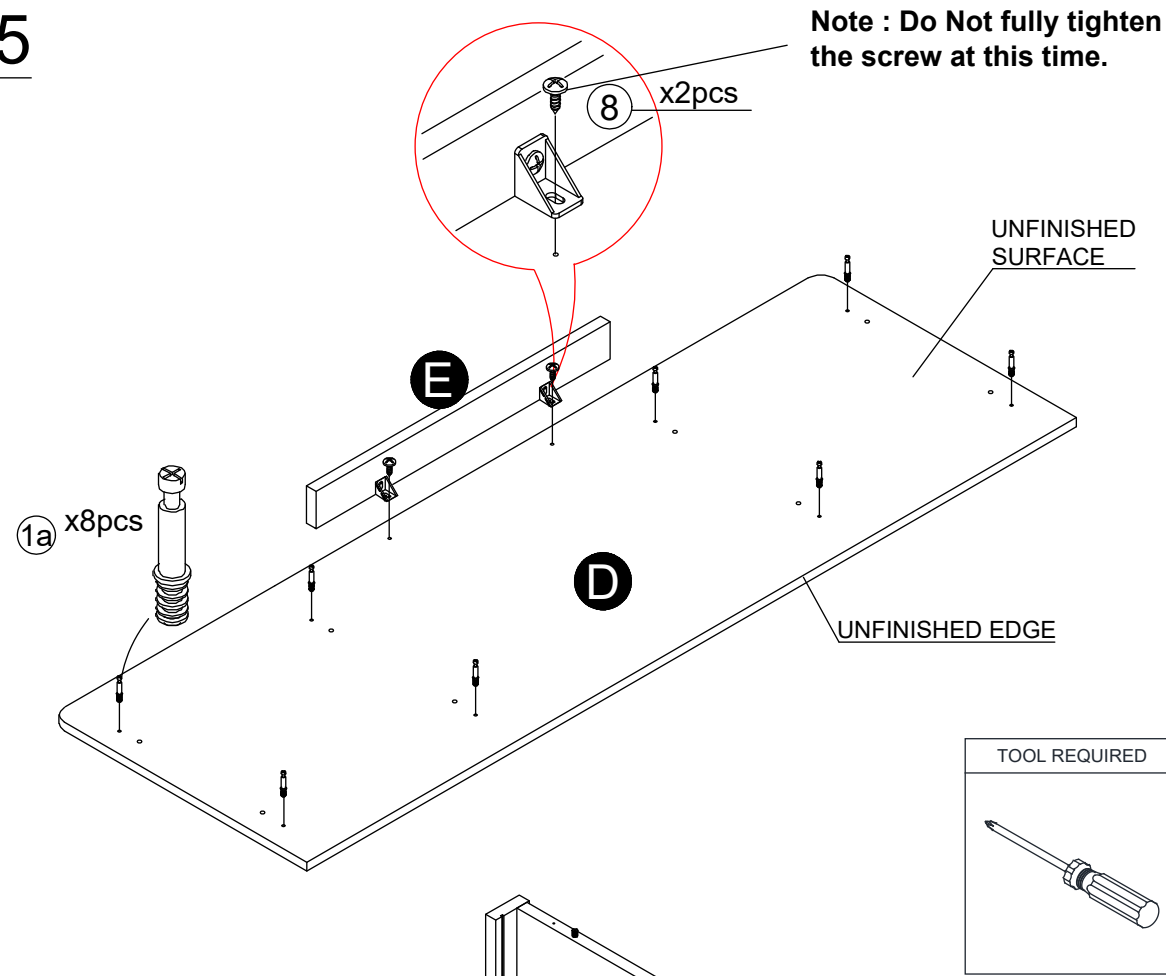

STEP 6

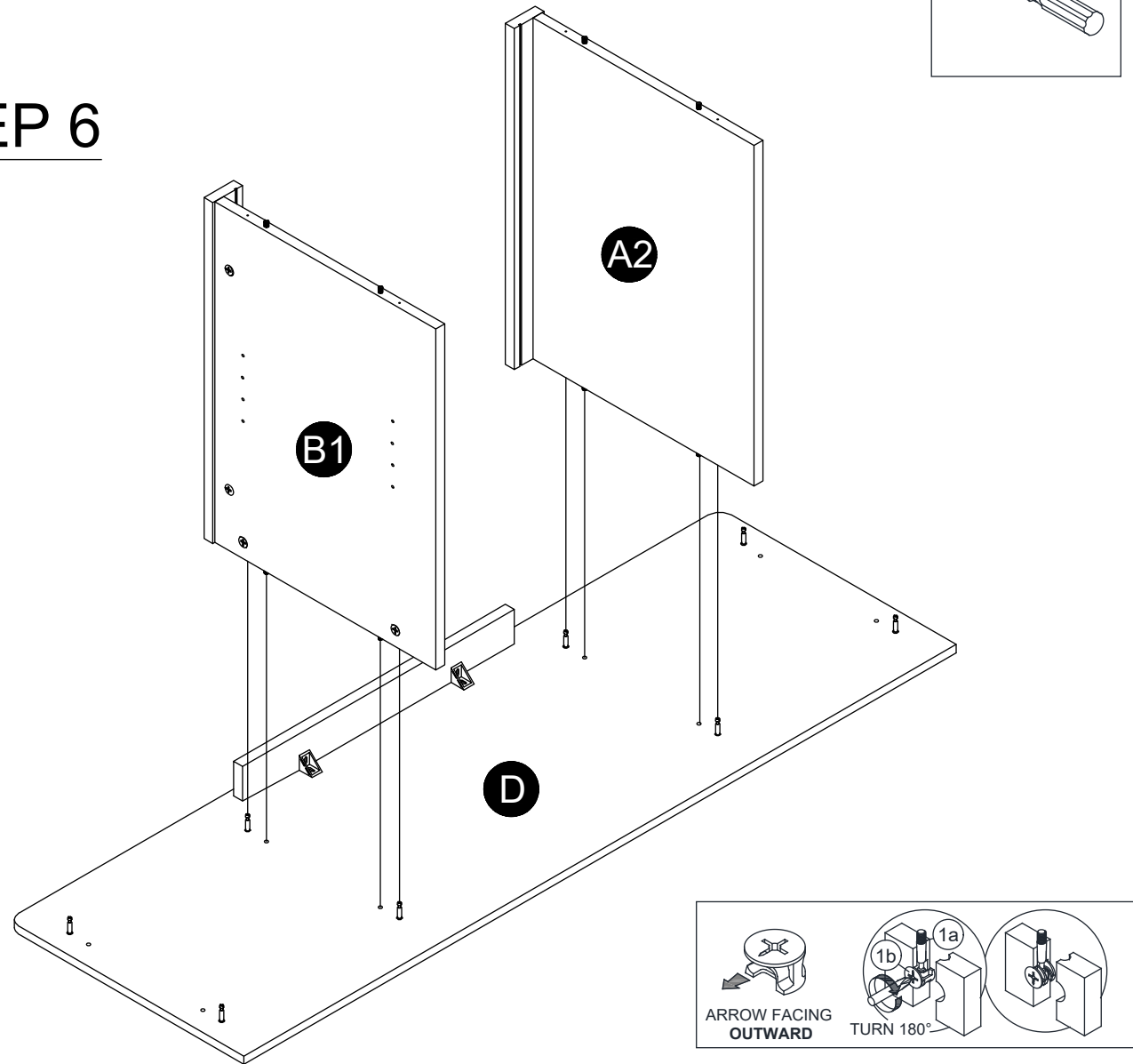

STEP 7

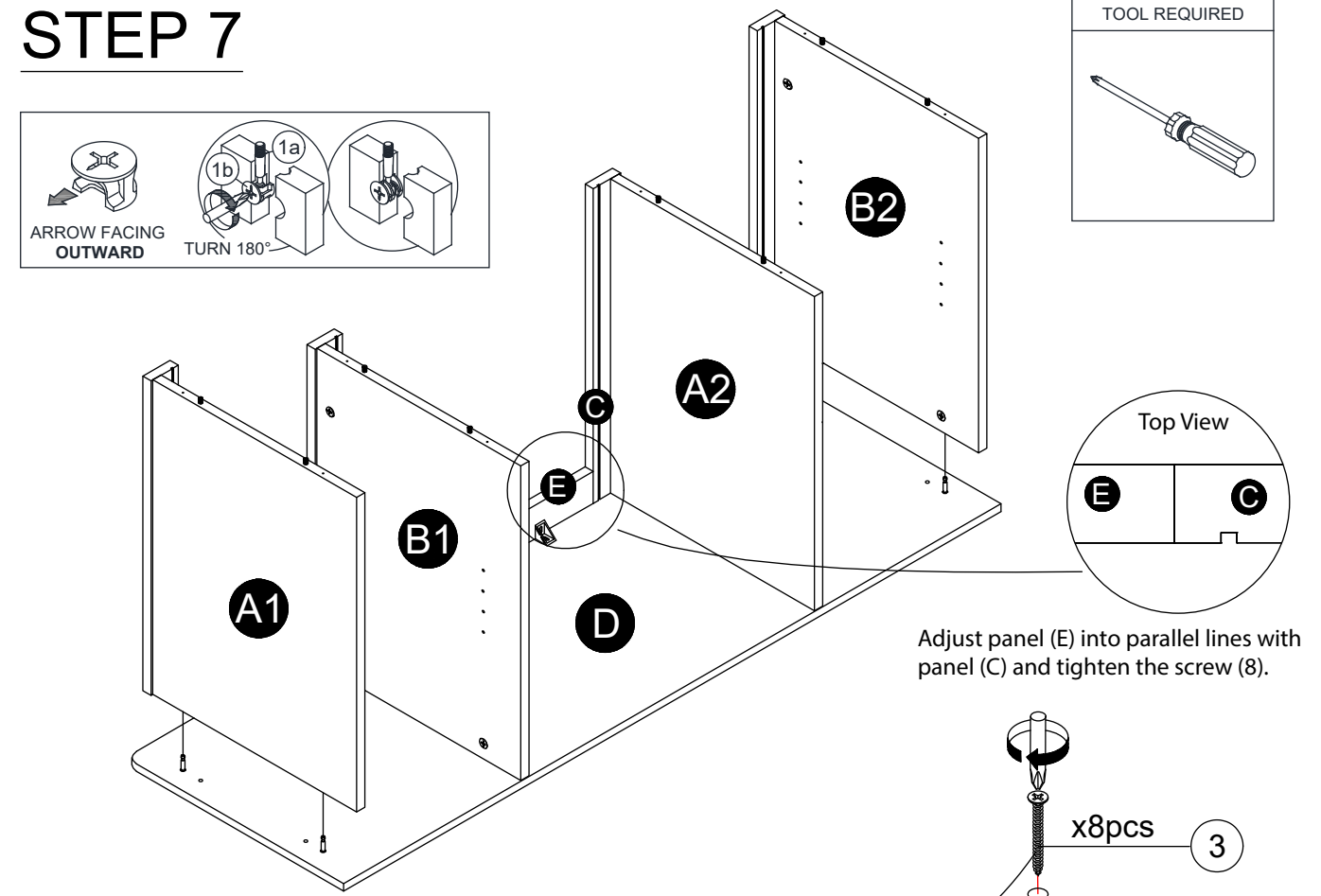

STEP 8

