

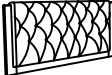













ASSEMBLY INSTRUCTION FOR ACME FURNITURE

Thank you for purchasing the quality product. Be sure to check all packing material carefully for small parts which may have come loose inside the carton during shipment. Separate, identify and count all parts and metal hardware. Compare with all parts list to be sure all parts are present. If any part(s) are missing or damaged, please contact your local furniture dealer. For efficient and speedy service, please indicate the model number and code letter of part(s) needed.

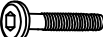
Do not fully tighten screws until fully assembled

COMPONENT PARTS		
DESCRIPTION	PART NAME	Q'TY (PCS)
①	HEADBOARD 	1
②	FOOTBOARD 	1
③	HEADBOARD LEG 	2
④	BED SLAT 	4
⑤	BED SLAT SUPPORT 	8
⑥	SIDE RAIL LEFT 	2
⑦	SIDE RAIL RIGHT 	2
⑧	BED SIDE RAIL LEG 	2

HARDWARE REQUIRED (BOX OF HEADBOARD)

- (A)  BOLT 1/4" x 1 3/16" - 12 PCS
- (B)  SPRING WASHER 1/4" - 12 PCS
- (C)  FLAT WASHER 1/4" - 12 PCS
- (D)  ALLEN KEY M4 - 1 PC
- (E)  ALLEN KEY M5 - 1 PC
- (F)  FLATHEAD CHIPBOARD SCREW 5/32" x 1 2/8" - 16 PCS









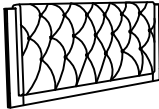

Attention:

*** Some number parts listed in the instruction sheet may not be in parts bags as they already be assembled. Carefully check parts and packing materials prior to ordering replacements.



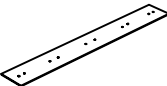

ASSEMBLY INSTRUCTION FOR ACME FURNITURE

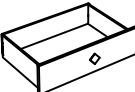
Thank you for purchasing the quality product. Be sure to check all packing material carefully for small parts which may have come loose inside the carton during shipment. Separate, identify and count all parts and metal hardware. Compare with all parts list to be sure all parts are present. If any part(s) are missing or damaged, please contact your local furniture dealer. For efficient and speedy service, please indicate the model number and code letter of part(s) needed.



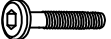

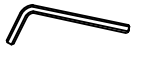
Do not fully tighten screws until fully assembled

COMPONENT PARTS		
DESCRIPTION	PART NAME	Q'TY (PCS)
①	HEADBOARD 	1
②	FOOTBOARD 	1
③	HEADBOARD LEG 	2
④	SIDE RAIL 	2
⑤	BED SLAT A 	3
⑥	BED SLAT B 	2
⑦	CONCEALED PANEL 	6
⑧	DRAWER SUPPORT RAIL 	1
⑨	SUPPORT LEG 1 	10
⑩	SUPPORT LEG 2 	1
⑪	FOOTBOARD DRAWER 	2

HARDWARE REQUIRED(BOX OF HEADBOARD)

- (A)  BOLT 1/4" x 1 3/8" - 4 PCS
- (B)  SPRING WASHER 1/4"- 4 PCS
- (C)  FLAT WASHER 1/4"- 4 PCS
- (D)  ALLEN KEY M4 - 1 PC
- (E)  FLATHEAD CHIPBOARD SCREW 5/32" x 1 2/8"- 8 PCS

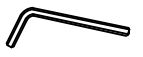
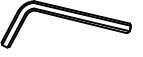
HARDWARE REQUIRED(BOX OF SIDE RAIL)

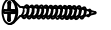
- (F)  FLATHEAD CHIPBOARD SCREW 5/32" x 1 2/8"- 12 PCS
- (G)  PAN HEADCHIPBOARD SCREW 4/32"x 13/16"- 30 PCS
- (H)  BOLT 1/4" x 2" - 11 PCS
- (I)  ALLEN KEY M4- 1 PC
- (J)  ALLEN KEY M5 - 1 PC
- (K)  FLAT WASHER 1/4"- 4 PCS(**FOR T-RUNNER ALIGNMENT IF NECESSARY USE ONLY**)
- (L)  FLATHEAD CHIPBOARD SCREW 5/32"x 13/16"- 2 PCS

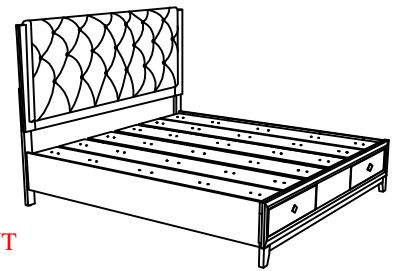

Attention:

*** Some number parts listed in the instruction sheet may not be in parts bags as they already be assembled. Carefully check parts and packing materials prior to ordering replacements.

How to assemble:

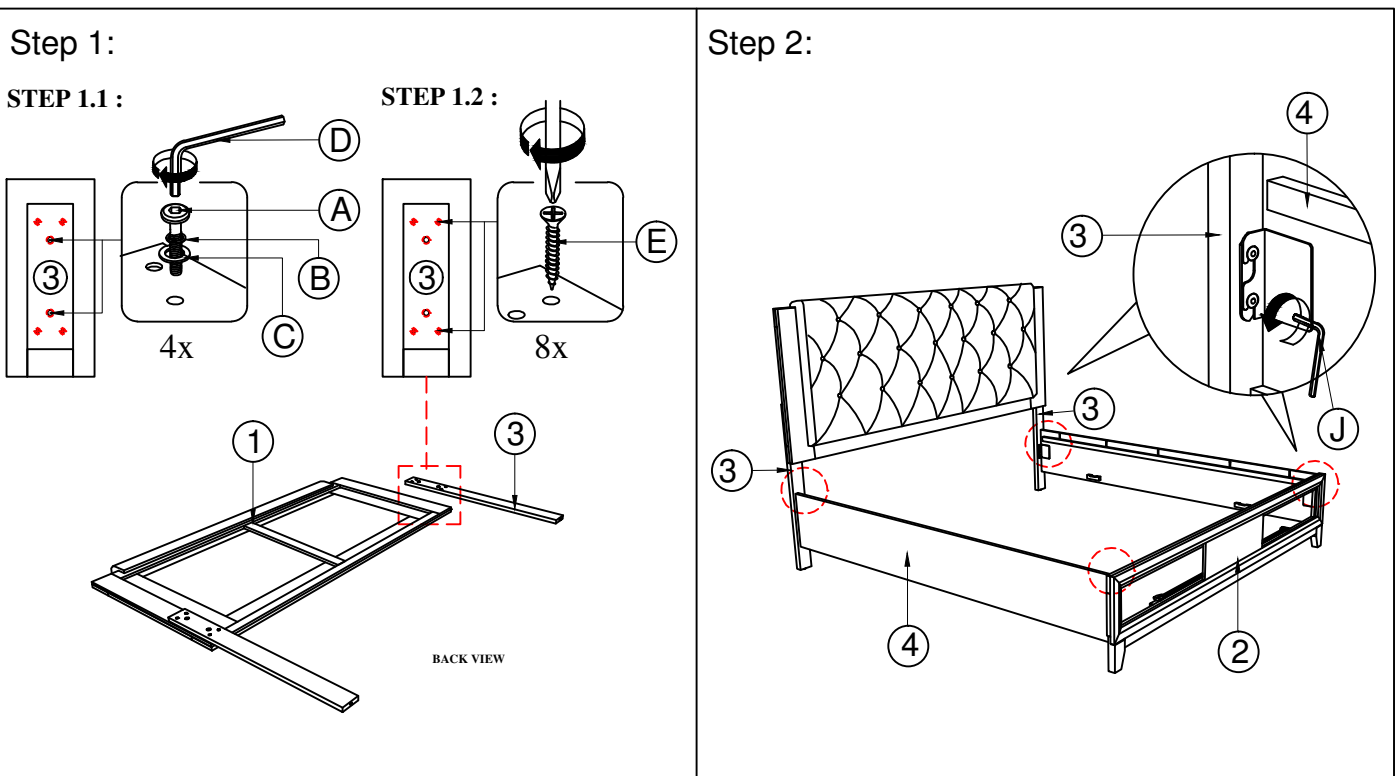

How to assemble:

Step 3:

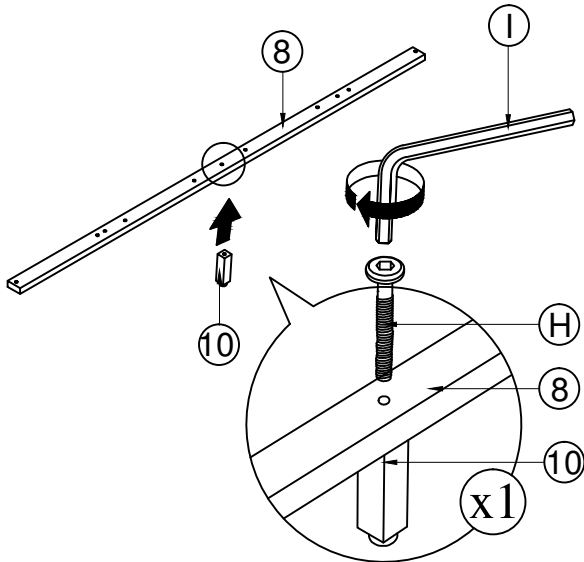

Step 4:

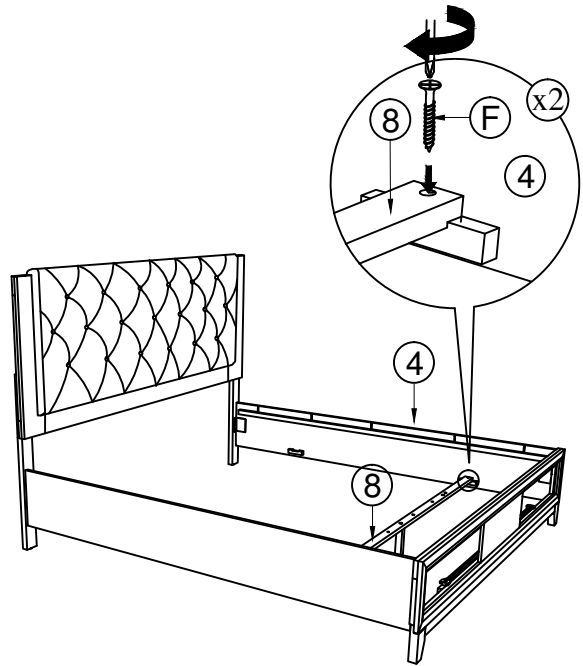

Step 5:

Remove protective single face before start Footboard Assembly

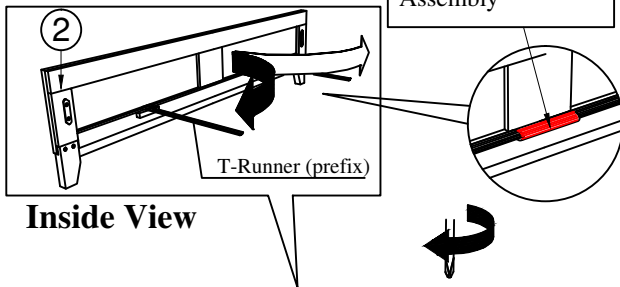

Inside View

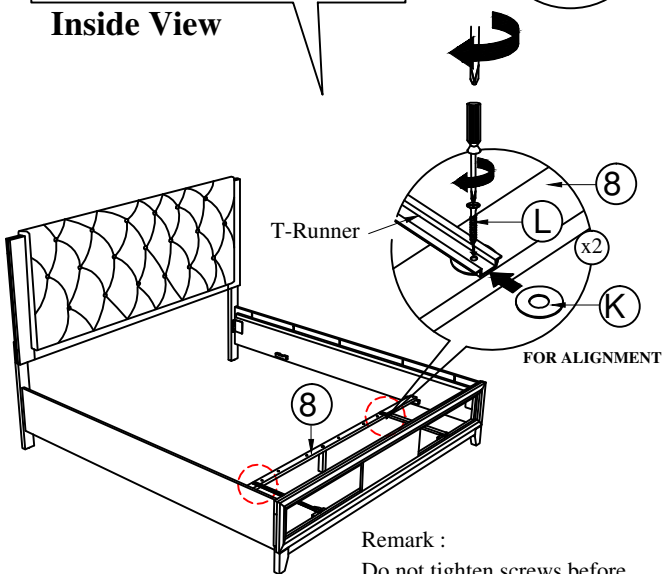

Remark :
Do not tighten screws before all the drawer in perfect position.

Step 6:

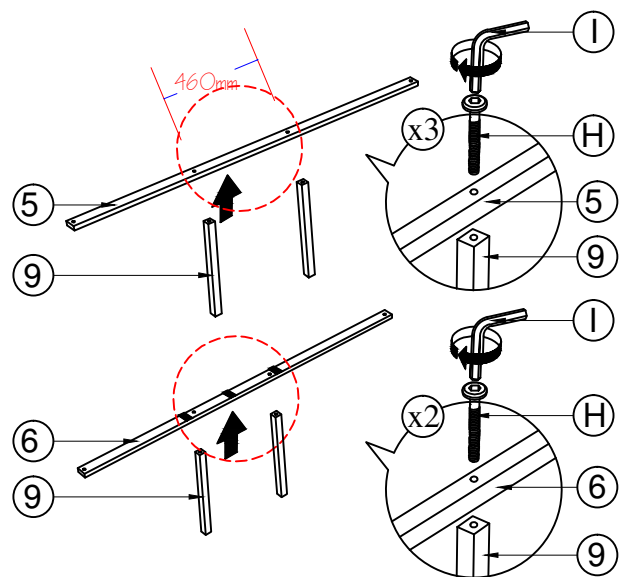

How to assemble:

Step 7:

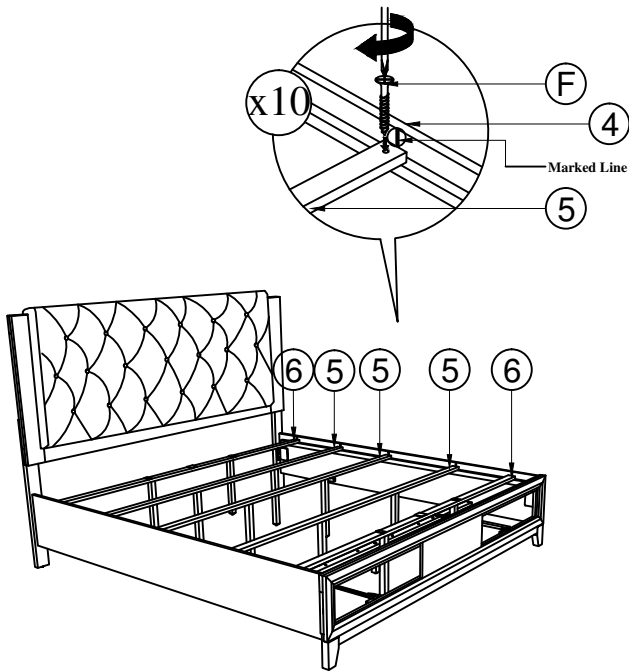

Step 8:

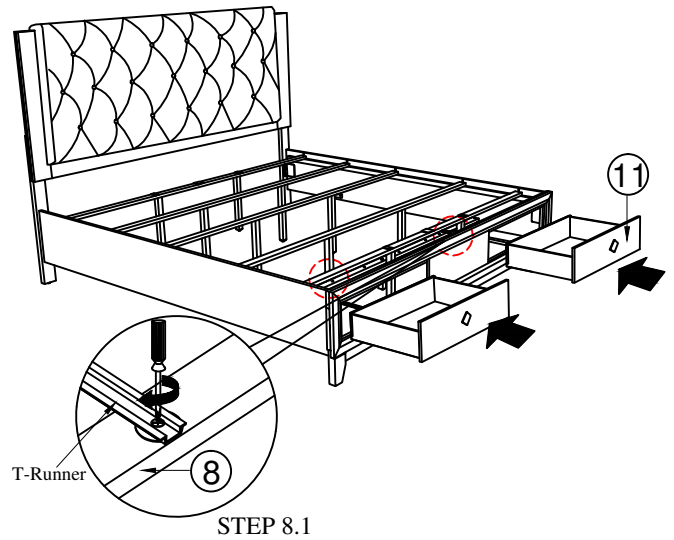

Step 9:

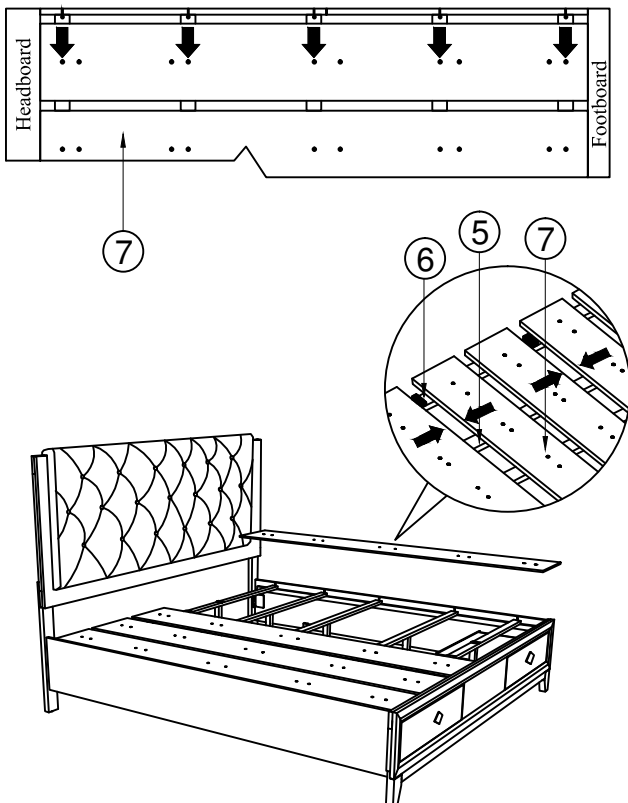

Step 10:
COMPLETE

