

# ASSEMBLY INSTRUCTIONS / NOTICE D'ASSEMBLAGE

Important note/ Note importante:

1. Place all wooden parts on a clean and smooth surface such as a rug or carpet to avoid scratching the parts. / Placer les pièces sur une surface propre et lisse tel qu'une couverture ou un tapis pour éviter d'endommager les pièces.
2. Kindly follow the assembly instructions step by step./ Veuillez suivre la notice d'assemblage, pas à pas.
3. Do not tighten all screws and bolts until the table is fully assembled./ Ne serrer les vis et boulons à fond que lorsque le produit est entièrement assemblé.
4. Unscrew the protective plastic supports from the metal insert of the table legs before assembly./ Dévisser les caches plastiques des embouts métalliques des pieds de la table avant l'assemblage.

## PARTS IDENTIFICATION / IDENTIFICATION DES PIÈCES

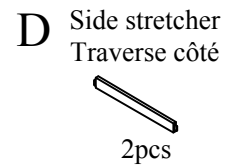
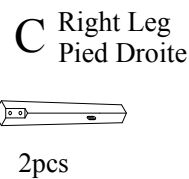
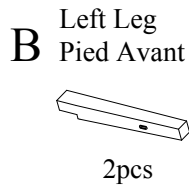
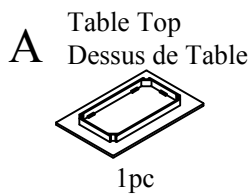

## HARDWARE IDENTIFICATION / IDENTIFICATION DES PIÈCES MONTAGE

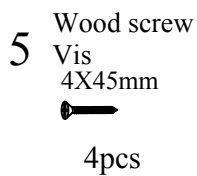
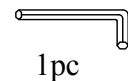
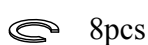
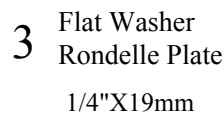
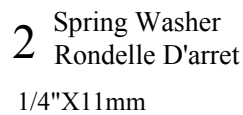
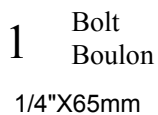

### STEP 1 / ÉTAPE 1

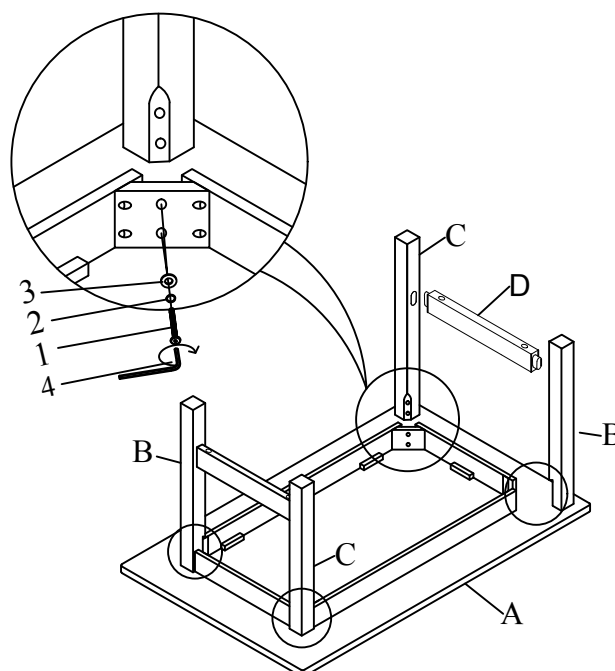

# ASSEMBLY INSTRUCTIONS / NOTICE D'ASSEMBLAGE

## STEP 2 / ÉTAPE 2

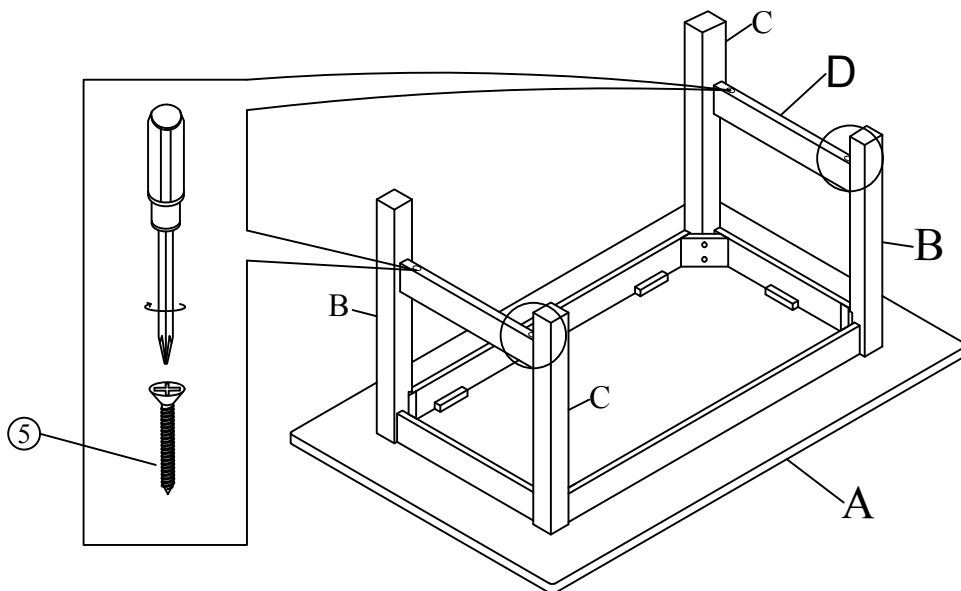

## COMPLETE/ ASSEMBLAGE TERMINÉ

