























ASSEMBLY INSTRUCTION

ITEM: QB

NO	PART LIST	QTY
1	 HEADBOARD CUSHION	1PC
2	 WINGS (L/R)	2PCS
3	 FOOTBOARD CUSHION	1PC
4	 LEGS	6PCS
5	 SIDE RAIL (L)	1PC
6	 SIDE RAIL (R)	1PC
7	 SLATS	3PCS
8	 SLAT WITH L-BRACKET	1PC
9	 SUPPORT LEGS WITH ADJUSTABLE FEET	4PCS
NO	HARDWARE LIST	QTY
A	 JCBB SCREW M8 X 20	4PCS
B	 JCBB SCREW M8 X 50	4PCS
C	 JCBC SCREW M6 X 80	6PCS
D	 JCBC SCREW M6 X 50	6PCS
E	 JCBC SCREW M6 X 35	4PCS
F	 SPRING WASHER (M8)	4PCS
G	 FLAT WASHER (M8)	4PCS
H	 SPRING WASHER (M6)	6PCS
I	 FLAT WASHER (M6)	6PCS
J	 SMALL WOOD DOWEL M8Ø x 30MM	6PCS
K	 BIG WOOD DOWEL M10Ø x 30MM	6PCS
L	 SCREW M4 X 32mm	8PCS
M	 L - KEY M5 X 65mm	1PC
N	 L - KEY M4 X 65mm	1PC

STEP 1

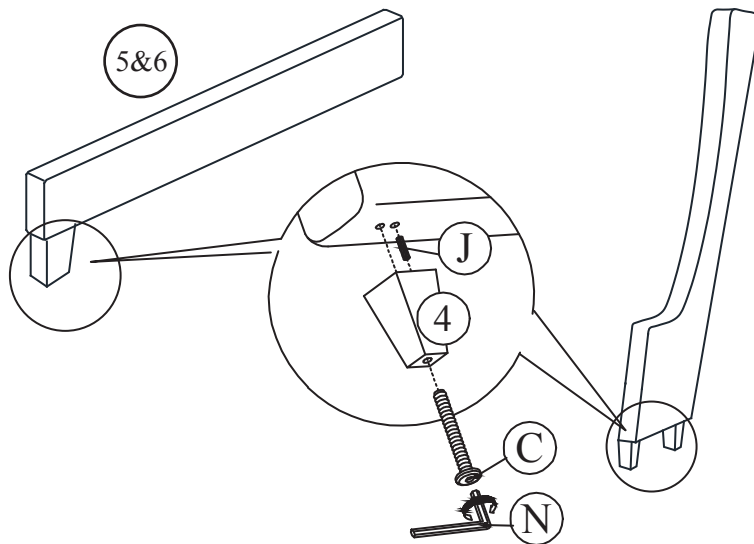

STEP 2

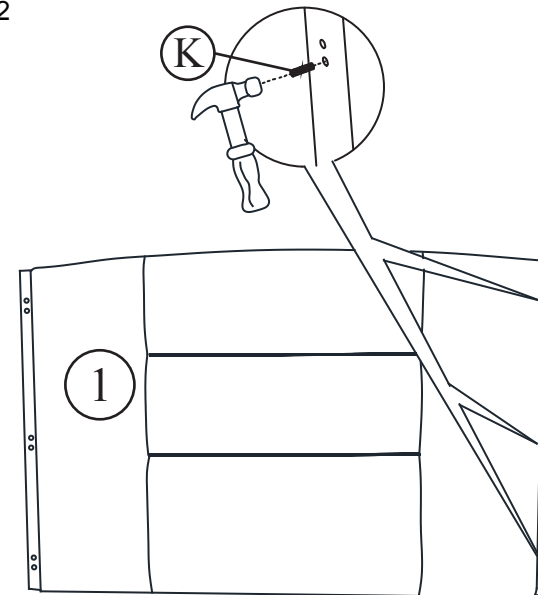

STEP 3

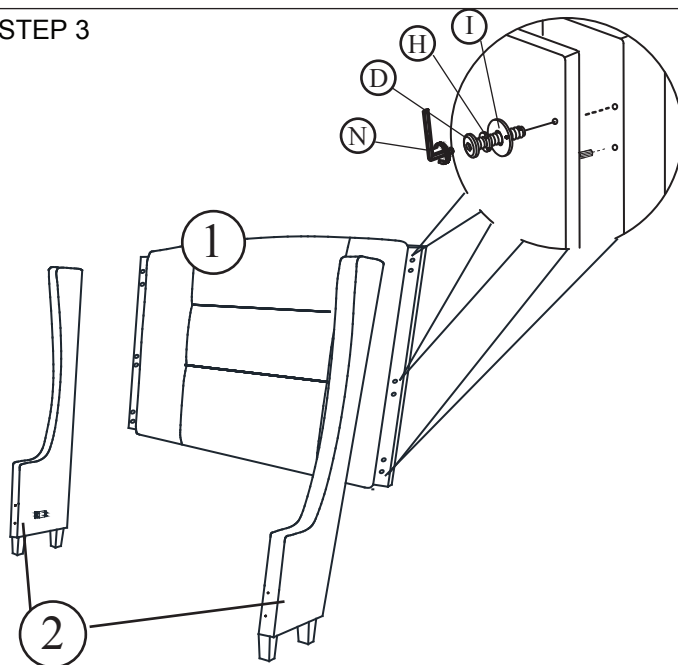

STEP 4

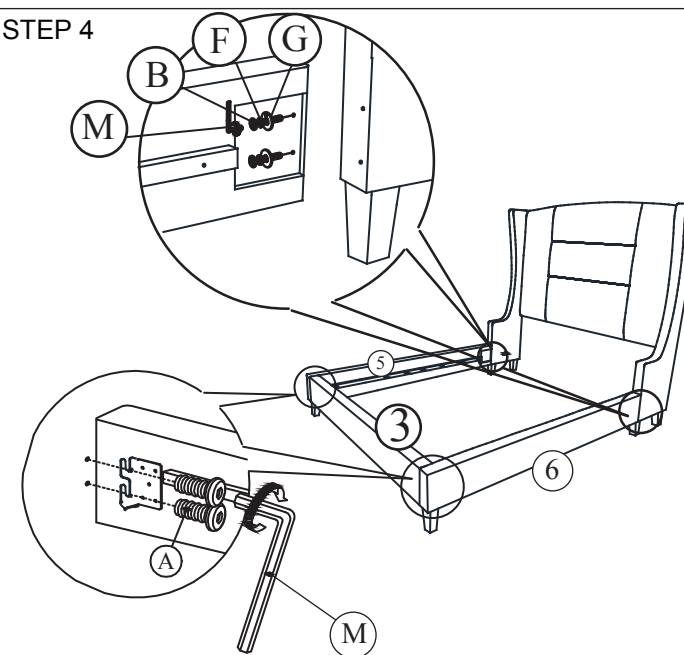

ASSEMBLY INSTRUCTION

STEP 5

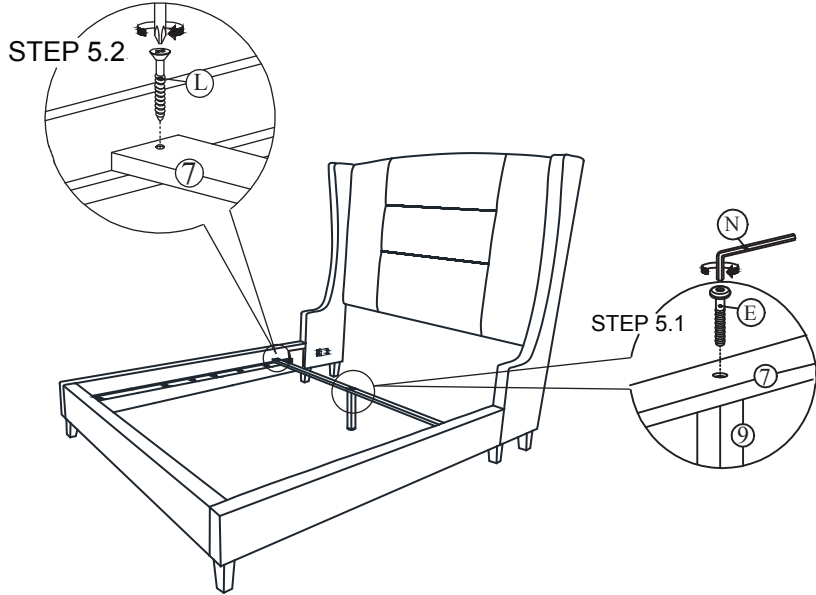

STEP 6

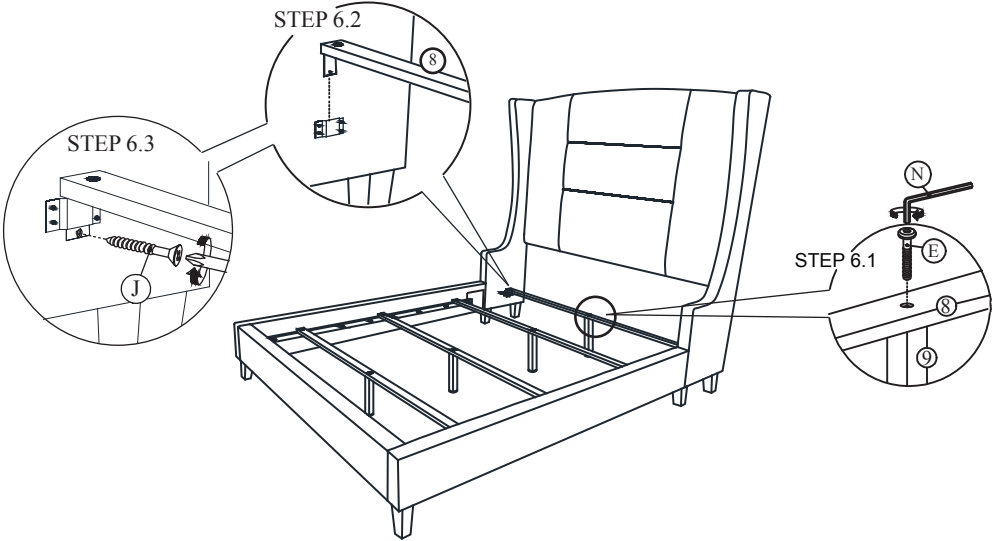

STEP 7

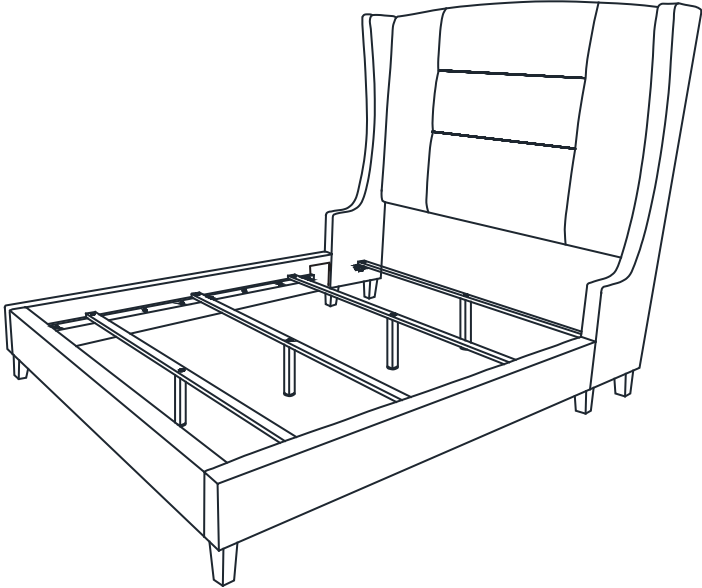

ASSEMBLY
COMPLETED