

ASSEMBLY INSTRUCTION

Friendly Reminder:

1. This sofa is packed in 5 boxes. Please assemble it After all boxes are received
2. As the cushions are all vacuum compressed, there will be some wrinkles. Please give your cushions up to 24-48 hours to reach its original size and the wrinkles will basically disappear.
3. Please do not open the compressed package until your sofa frame is completely assembled

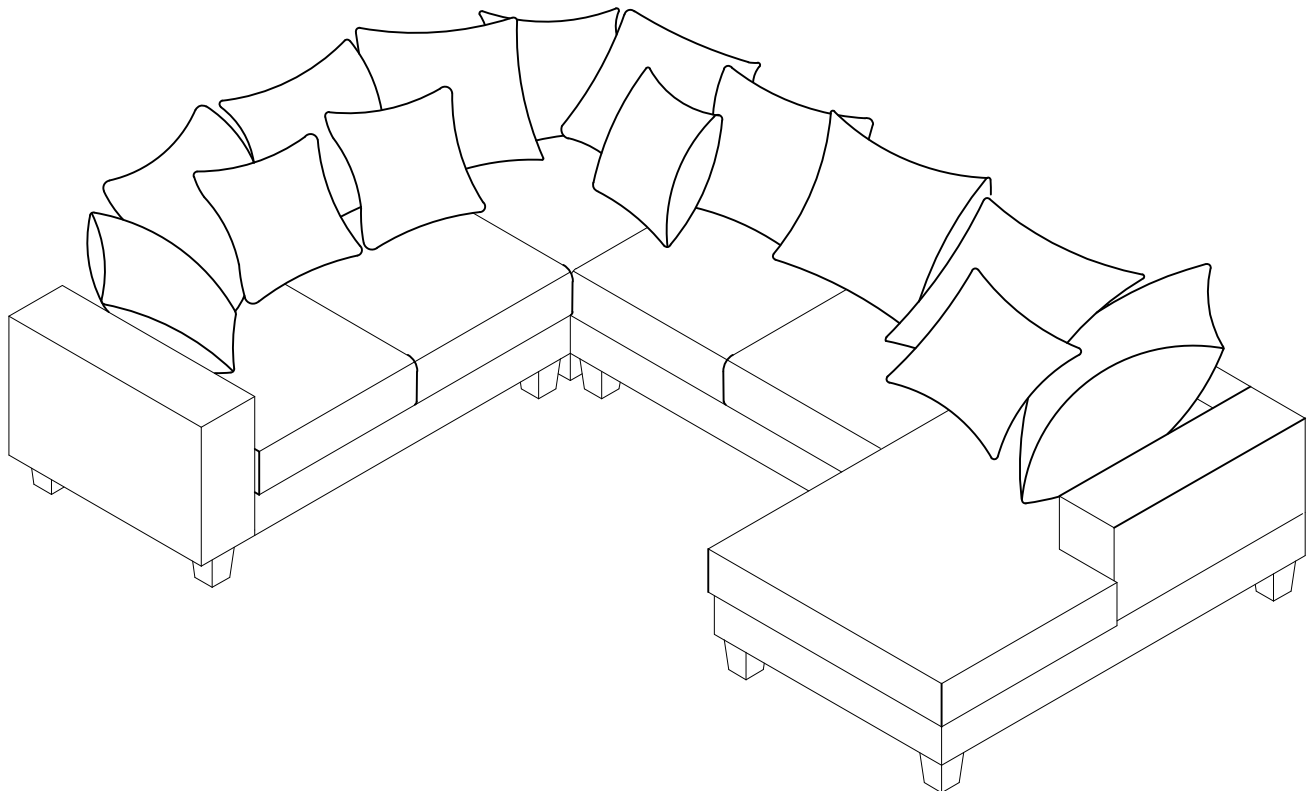





Return & Warranty policy:



- We strive to offer the highest quality products, and we also try our best to satisfy each and every customer that orders from us with replacement parts or service as needed.
- If the item damaged or defective, please take photos as evidence for replacements and refunds.
- Please do not return to store, contact the seller if you have any troubles with this product.

ASSEMBLY INSTRUCTION

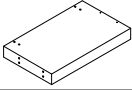
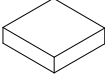

HARDWARE

NO	DESCRIPTION	SKETCH	QTY
①	Bolt M8 x 80		28 PCS
②	Bolt M8 x 20		12 PCS
③	Washer M8x1		28 PCS
④	Allen key M4		1 PCS
⑤	I - Bracket		6 PCS

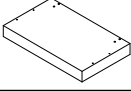
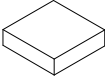

PARTS LIST

NO	DESCRIPTION	SKETCH	QTY
SL	Left Seat Frame		1 PCS
A	Seat Cushion		2 PCS
D	Big Pillow		4 PCS

PARTS LIST



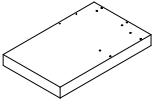
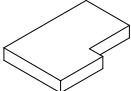

NO	DESCRIPTION	SKETCH	QTY
SM	Middle Seat Frame		1 PCS
A	Seat Cushion		2 PCS
D	Big Pillow		4 PCS

PARTS LIST



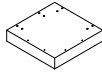
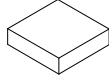



NO	DESCRIPTION	SKETCH	QTY
SR	Right Seat Frame		1 PCS
B	Right Cushion		1 PCS
E	Small Pillow		4 PCS
F	Plastic Legs		4 PCS

ASSEMBLY INSTRUCTION

PARTS LIST

NO	DESCRIPTION	SKETCH	QTY
SC	Corner Seat Frame		1 PCS
C	Corner Cushion		1 PCS
D	Big Pillow		2 PCS
AL	Left Arm		1 PCS
AR	Right Arm		1 PCS

PARTS LIST

NO	DESCRIPTION	SKETCH	QTY
BL	Left Backrest		1 PCS
BA	Left Corner Backrest		1 PCS
BB	Right Corner Backrest		1 PCS
BM	Middle Backrest		1 PCS
BR	Right Backrest		1 PCS
F	Plastic Legs		12 PCS

All parts and hardware.

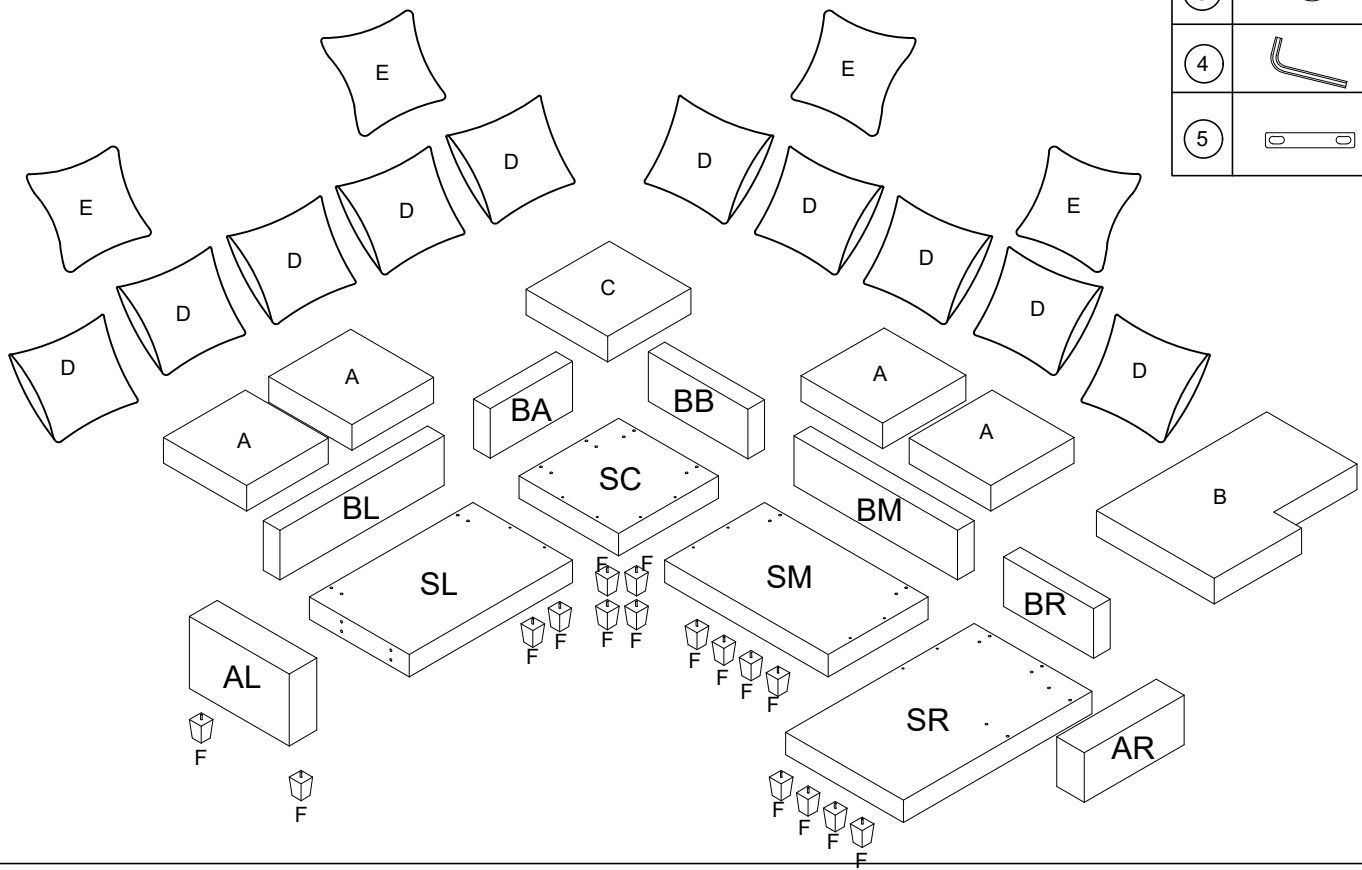

①		28 PCS
②		12 PCS
③		28 PCS
④		1 PCS
⑤		6 PCS

DIAGRAM 1:

1. Tighten 2 Legs (Parts F) into the holes on the Left arm (Part AL).
2. Tighten 2 Legs (Parts F) into the holes on the Left seat frame (Part SL).
3. Connect Left seat frame (Part SL) and Left arm (Part AL) with Bolt M8 x 80 (Hardware 1) and washer M8 x 1 (Hardware 3) by Allen key M4 (Hardware 4).
4. Connect Left seat frame (Part SL) and Left backrest (Part BL) with Bolt M8 x 80 (Hardware 1) and washer M8 x 1 (Hardware 3) by Allen key M4 (Hardware 4).

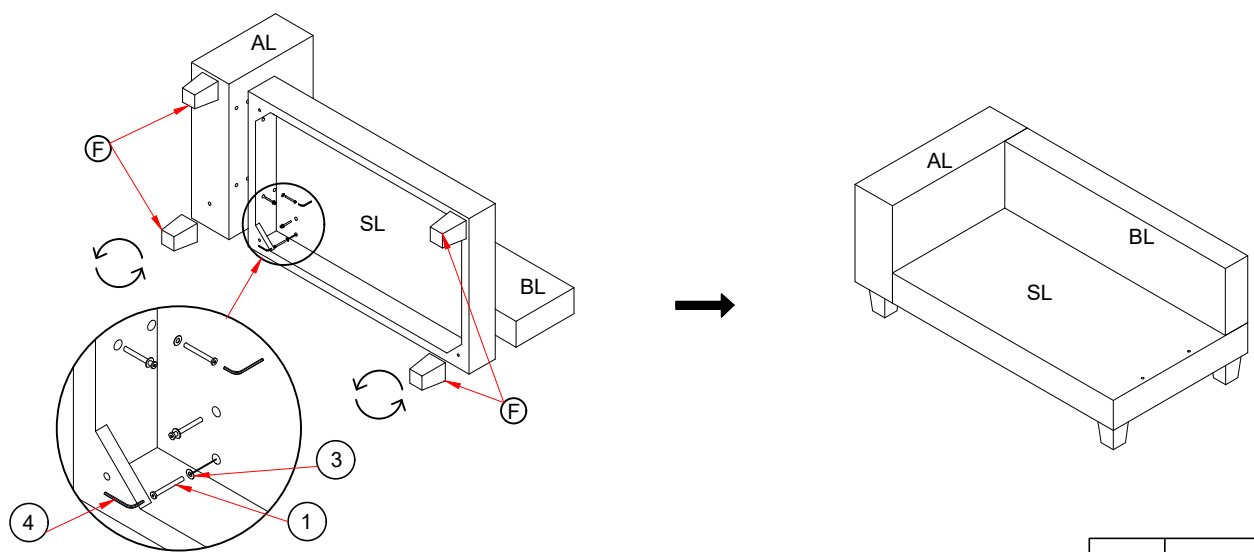

①		8 PCS
③		8 PCS

DIAGRAM 2

1. Tighten 4 Legs (Parts F) into the holes on Corner seat frame (Part SC).
2. Connect Left seat frame (Part SL) and Left corner backrest (Part BA) with Bolt M8 x 80 (Hardware 1), washer M8 x 1 (Hard ware 3) by Allen key M4 (Hardware 4).
3. Connect Left seat frame (Part SL) and Right corner backrest (Part BB) with Bolt M8 x 80 (Hardware 1), washer M8 x 1 (Hard ware 3) by Allen key M4 (Hardware 4).

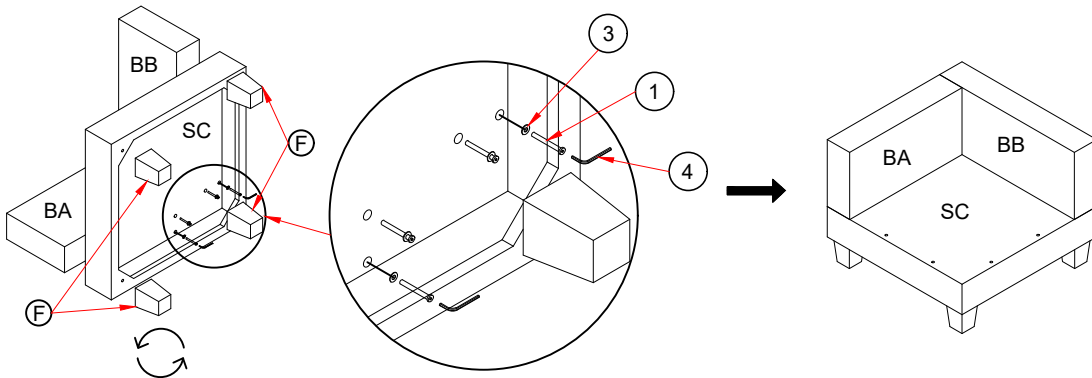

1		8 PCS
3		8 PCS

DIAGRAM 3

1. Tighten 4 Legs (Parts F) into the holes on Middle seat frame (Part SM).
2. Connect Middle seat frame (Part SL) and Middle backrest (Part BM) with Bolt M8 x 80 (Hardware 1), washer M8 x 1 (Hard ware 3) by Allen key M4 (Hardware 4).

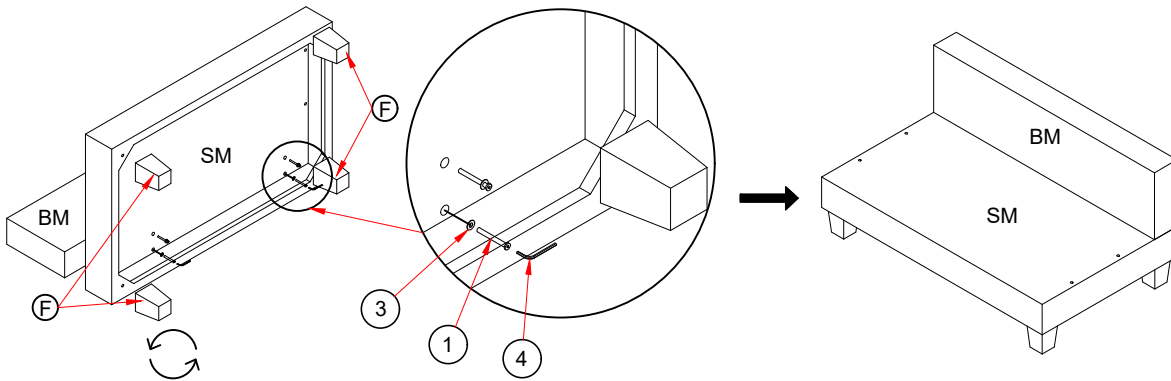

1		4 PCS
3		4 PCS

DIAGRAM 4

1. Tighten 4 Legs (Parts F) into the holes on Right seat frame (Part SC).
2. Connect Right seat frame (Part SR) and Right backrest (Part BR) with Bolt M8 x 80 (Hardware 1), washer M8 x 1 (Hard ware 3) by Allen key M4 (Hardware 4).
3. Connect Right seat frame (Part SR) and Right armrest (Part AR) with Bolt M8 x 80 (Hardware 1), washer M8 x 1 (Hard ware 3) by Allen key M4 (Hardware 4).

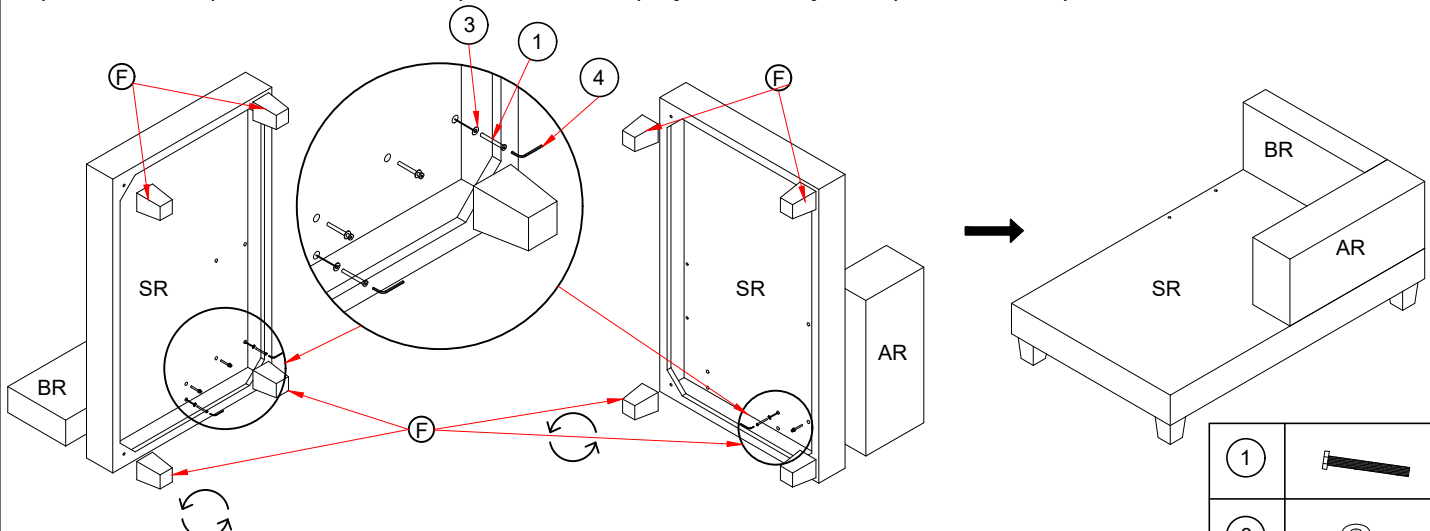

1		8 PCS
3		8 PCS

DIAGRAM 5

1. Connect Left seat frame (Part SL) and Corner seat frame (Part SC) with Bolt M8 x 20 (Hardware 2), I-Bracket (Hardware 5) by Allen key (Hardware 4).
2. Connect Corner seat frame (Part SC) and Middle seat frame (Part SM) with Bolt M8 x 20 (Hardware 2), I-Bracket (Hardware 5) by Allen key (Hardware 4).
3. Connect Middle seat frame (Part SM) and Right seat frame (Part SR) with Bolt M8 x 20 (Hardware 2), I-Bracket (Hardware 5) by Allen key (Hardware 4).

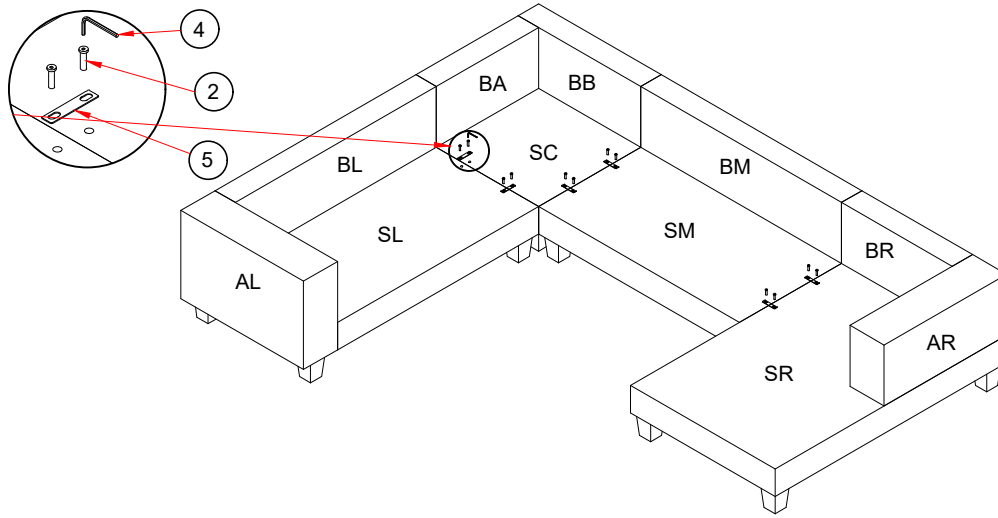

2		12 PCS
5		6 PCS

DIAGRAM 6

1. Remove the Seat cushion (Part A), the Corner cushion (Part C), the Right cushion (Part B).

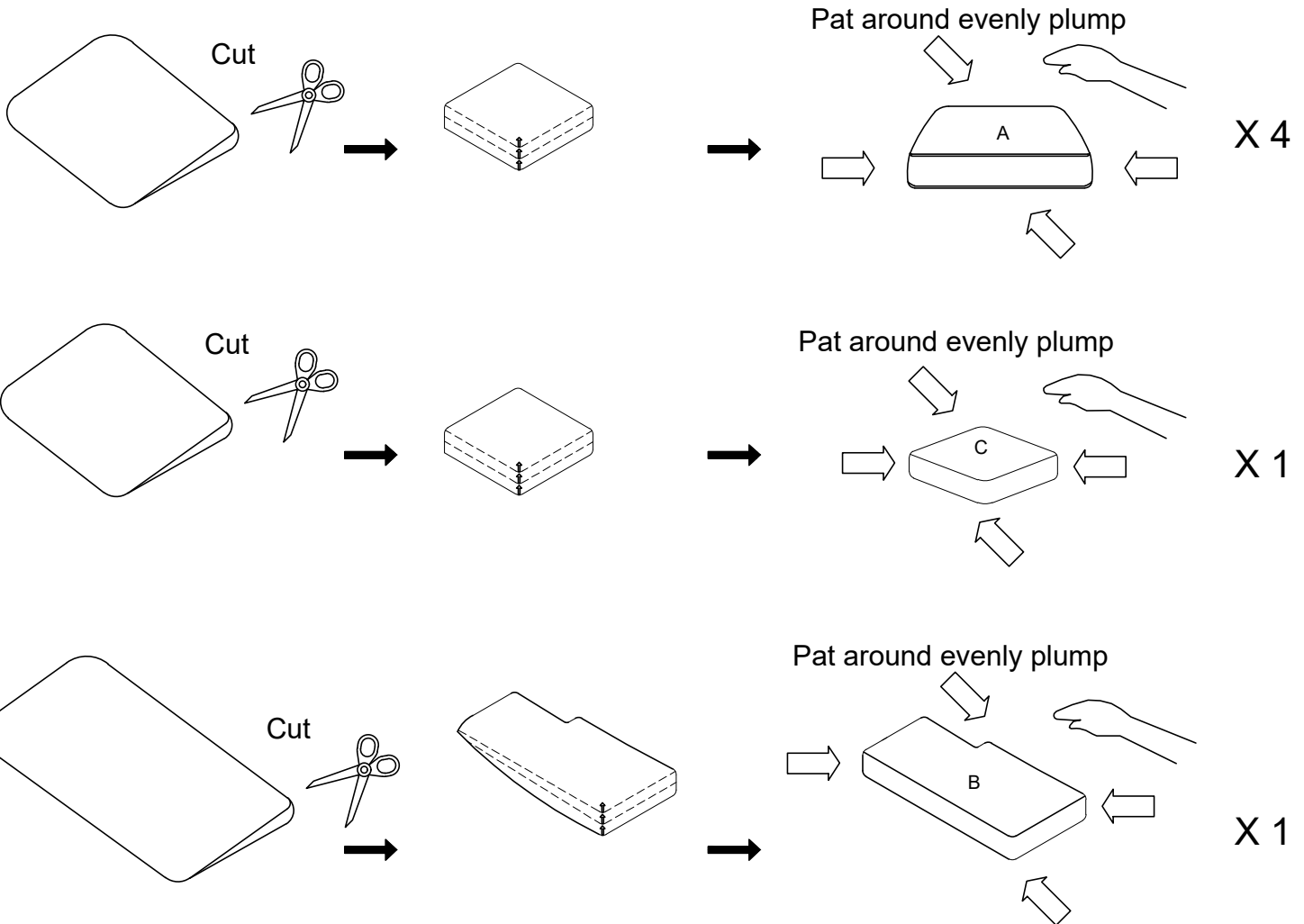

DIAGRAM 7

1. Remove Big pillow (Part D), Small pillow (Part E).

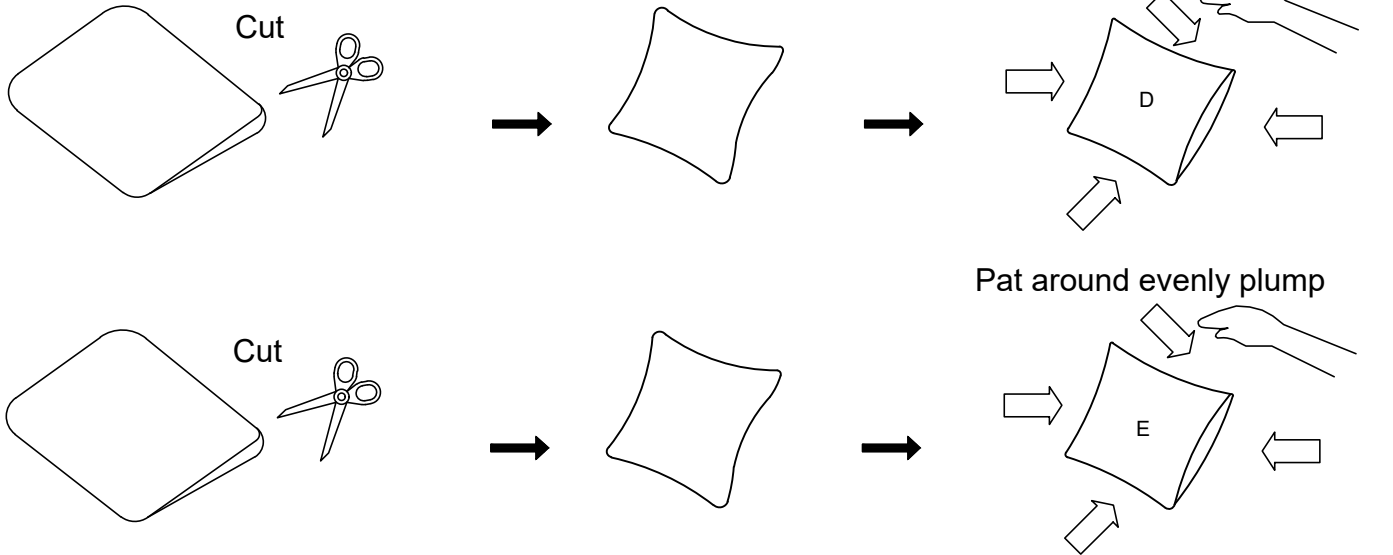

DIAGRAM 8

1. Put the Seat cushion (Part A), Right cushion (Part B), Corner cushion (Part C) on the sofa. Recheck all the bolts before you sit on the sofa.

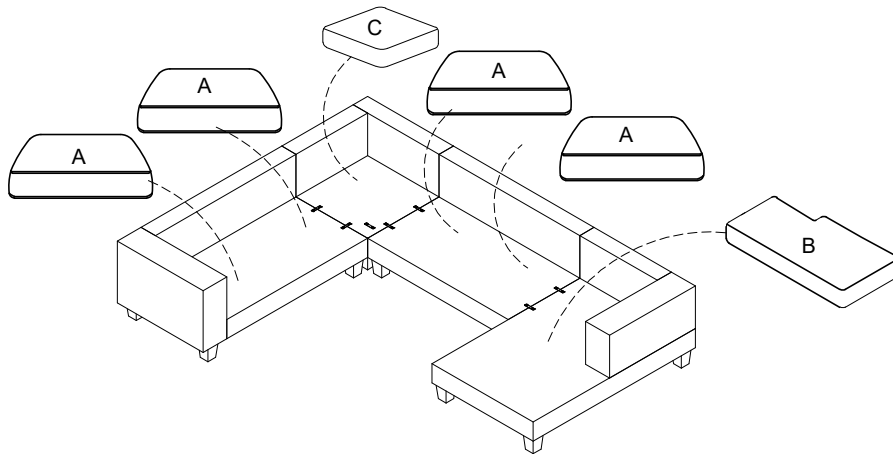
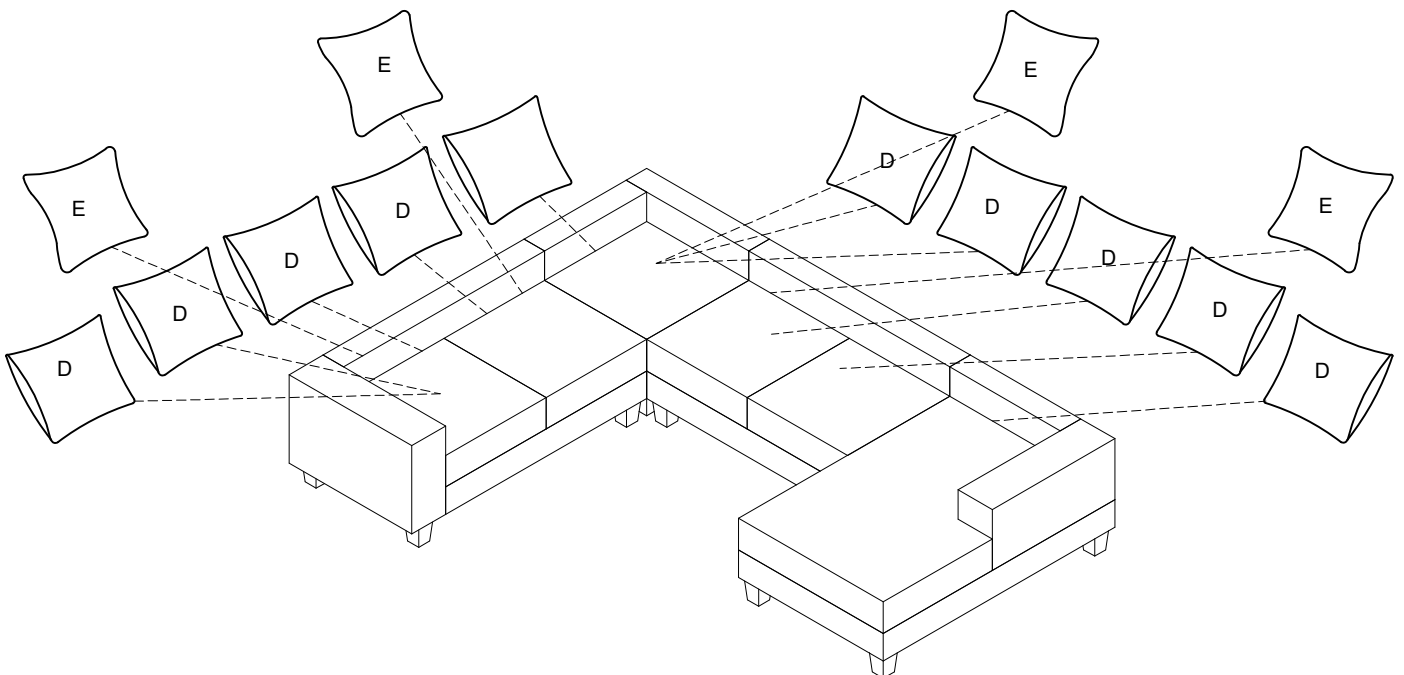

DIAGRAM 9

1. Put the Big pillow (Part D), Small pillow (Part E) on the sofa.



TIPS:

1. Please do not open the compress packaging until your sofa frame is completely assembled.
2. Compressed cushions and pillows need to be fully fulfilled within 24-48 hours your perfect use.
3. Please keep children away from plastic bags or any small pieces of stuff.

