

Product Installation Instructions

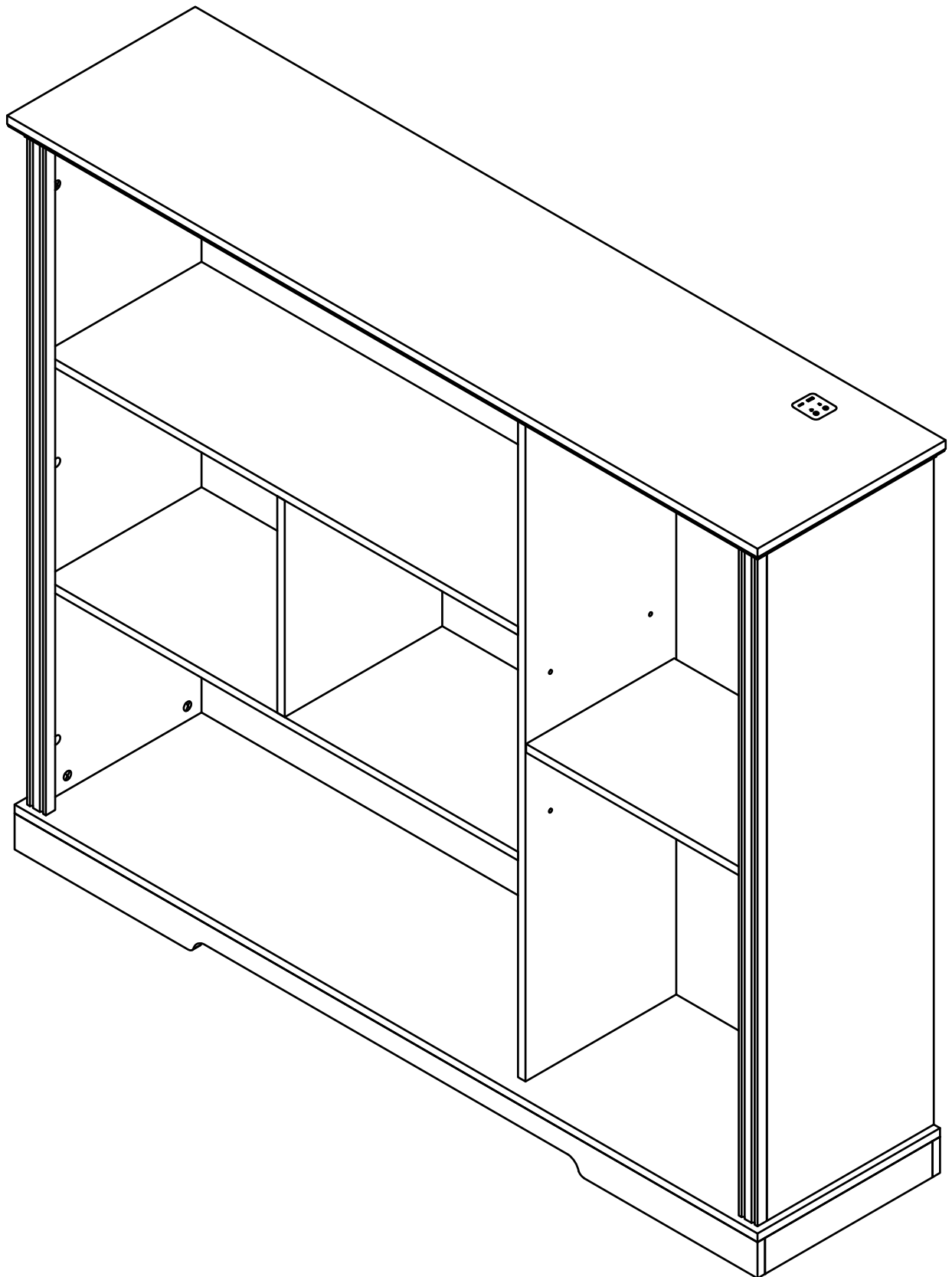

Product structure decomposition

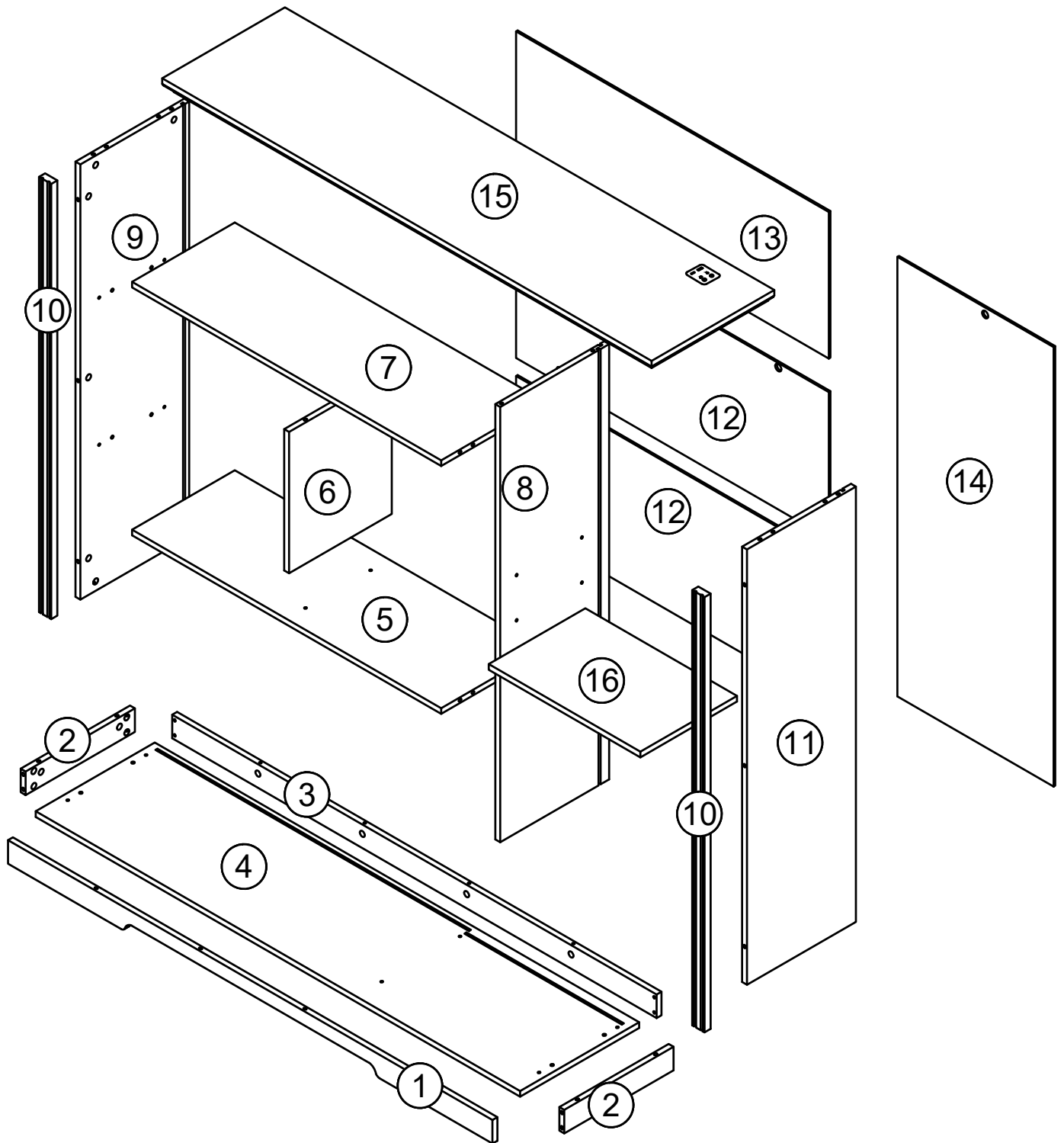

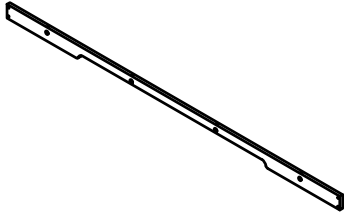

1x1

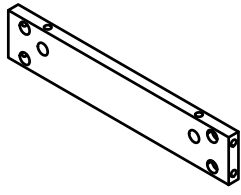

2x2

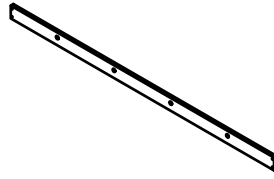

3x1

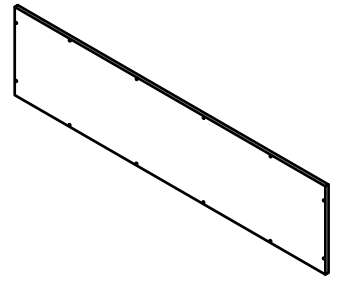

4x1

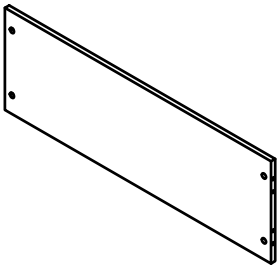

5x1

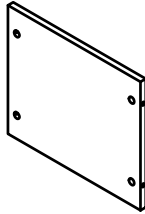

6x1

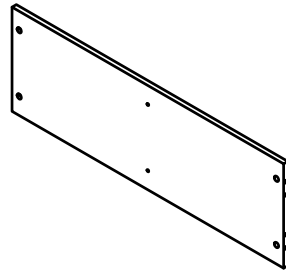

7x1

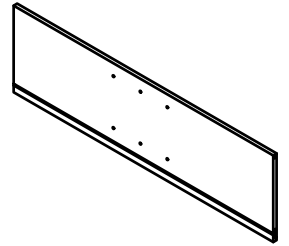

8x1

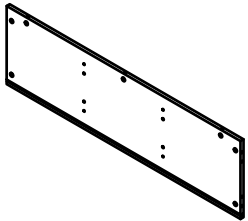

9x1



10x2

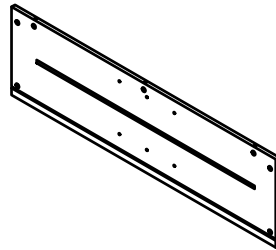

11x1

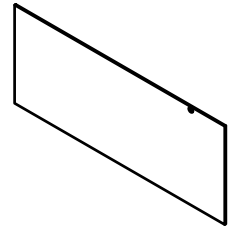

12x2

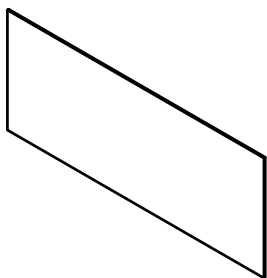

13x1

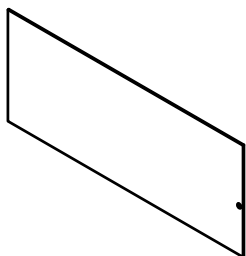

14x1

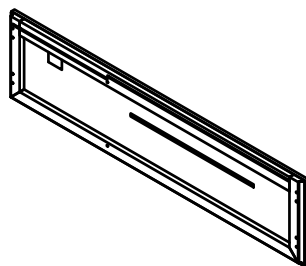



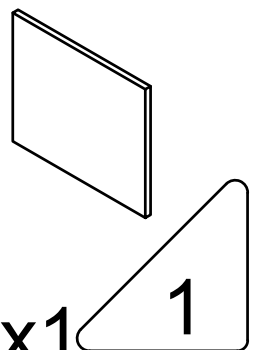



15x1

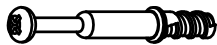

16x1

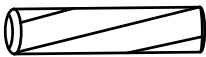
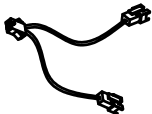
1

Accessories list

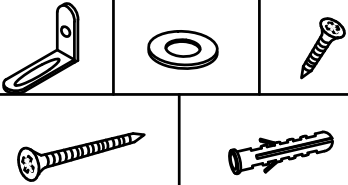
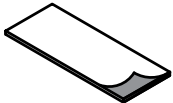
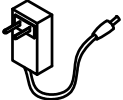

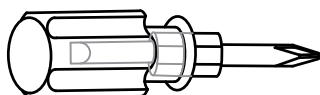



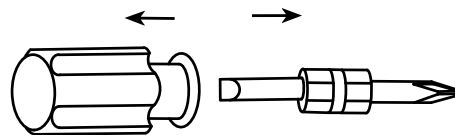

| | | | |
|---|---|---------------------------------|----------------|
| A |  | Two In One Screw (6x28mm) | 46pcs +4pcs |
| B |  | Two In One Nut (10x12mm) | 46pcs +4pcs |
| C |  | Wood Chipping (6x30mm) | 16pcs +2pcs |
| D |  | 1 bis 2 power extension cable | 2pcs |
| E |  | Fixing clip & screw (3x16mm) | 18pcs +2pcs |
| F |  | Foot nail | 4pcs +2pcs |
| G |  | Laminate support nail | 4pcs +2pcs |
| H |  | Anti fall hardware | 2pcs |
| I |  | Non-slip pads | 6pcs +2pcs |
| / |  | AC/DC Adapter (12V=3.0A) | 1pcs |

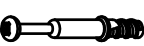

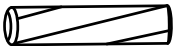
1pcs

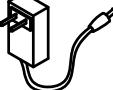

Double-head screwdriver, use as required

| | | | | | | | | | |
|---|---|--------|---|---|--------|---|---|--------|--|
| A |  | 46 pcs | B |  | 46 pcs | C |  | 16 pcs | |
| D |  | 2 pcs | E |  | 18 pcs | F |  | 4 pcs | |
| G |  | 4 pcs | H |  | 2 pcs | I |  | 6 pcs | |
| |  | 1 pcs | | | | | | | |

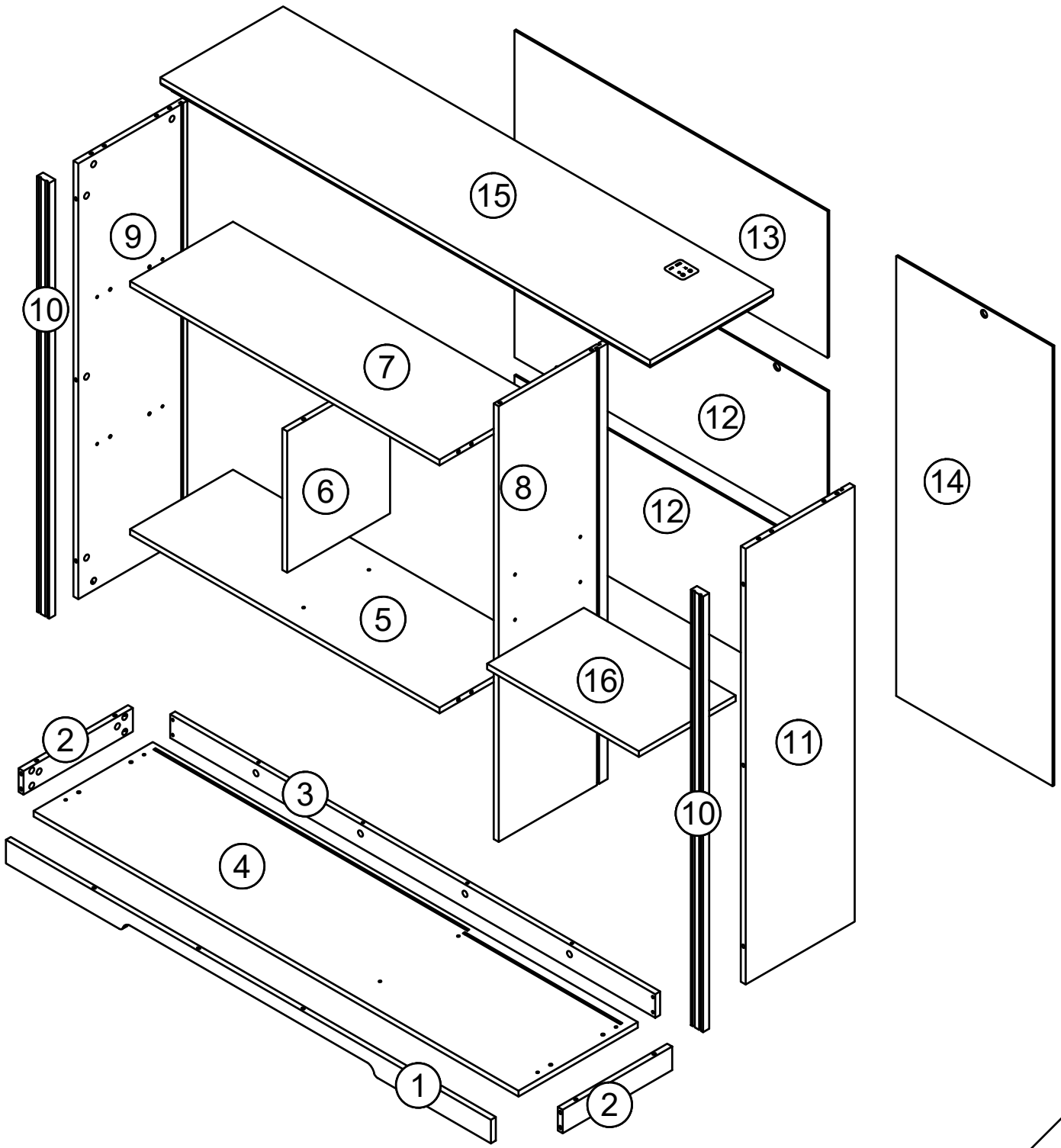

Step 1

(A)

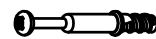

x 4

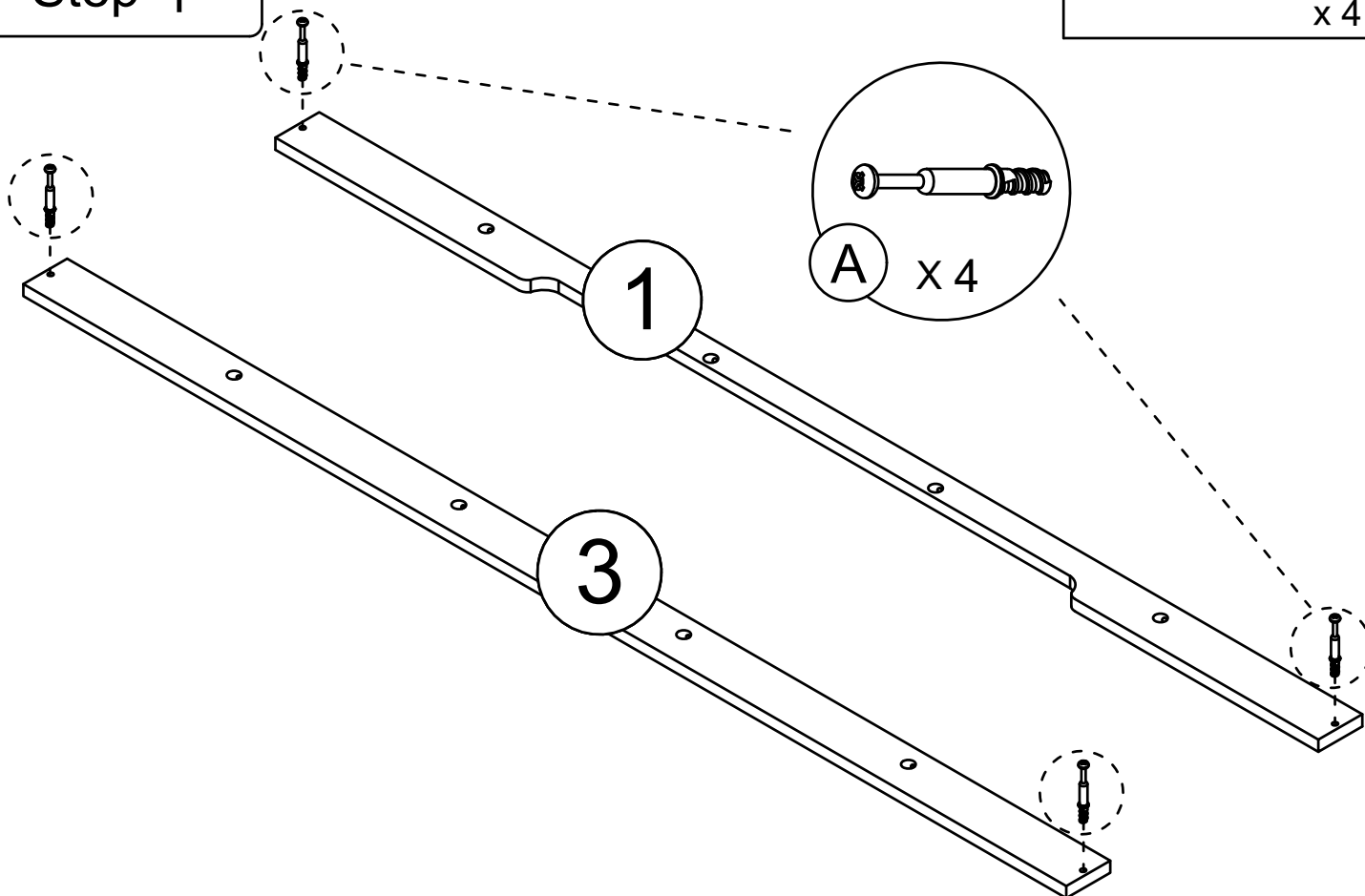

Step 2

(B)



x 2

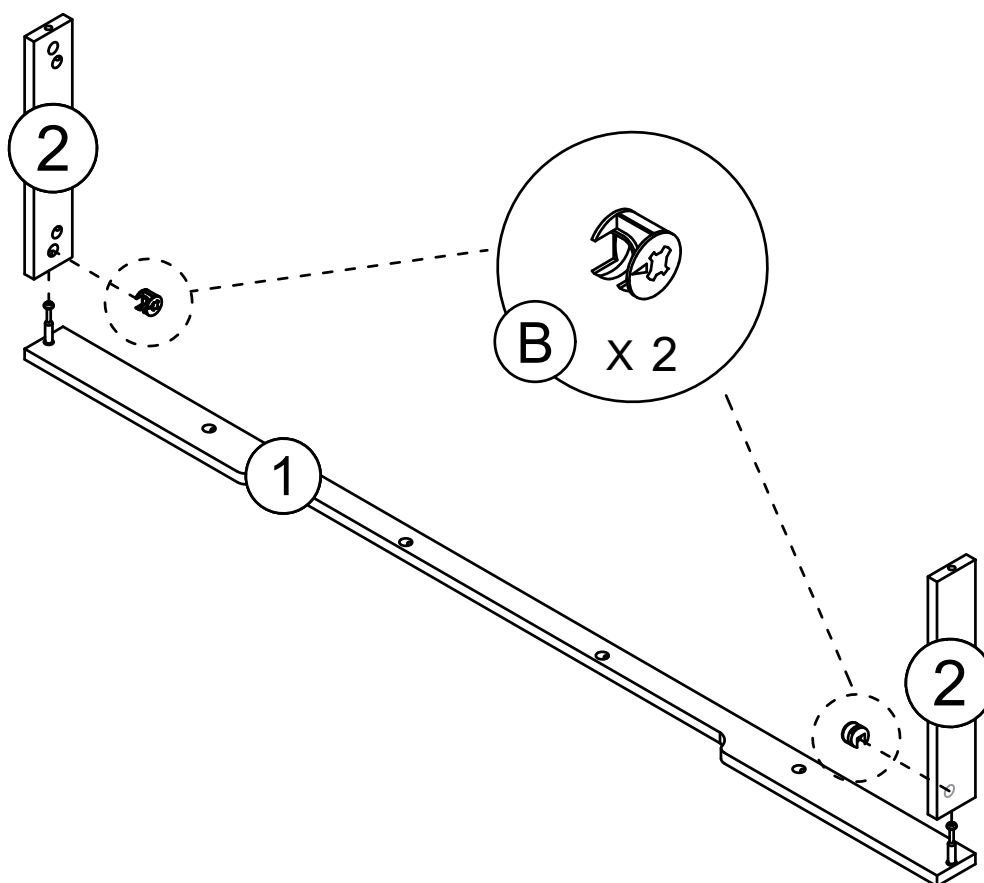

4

Step 3

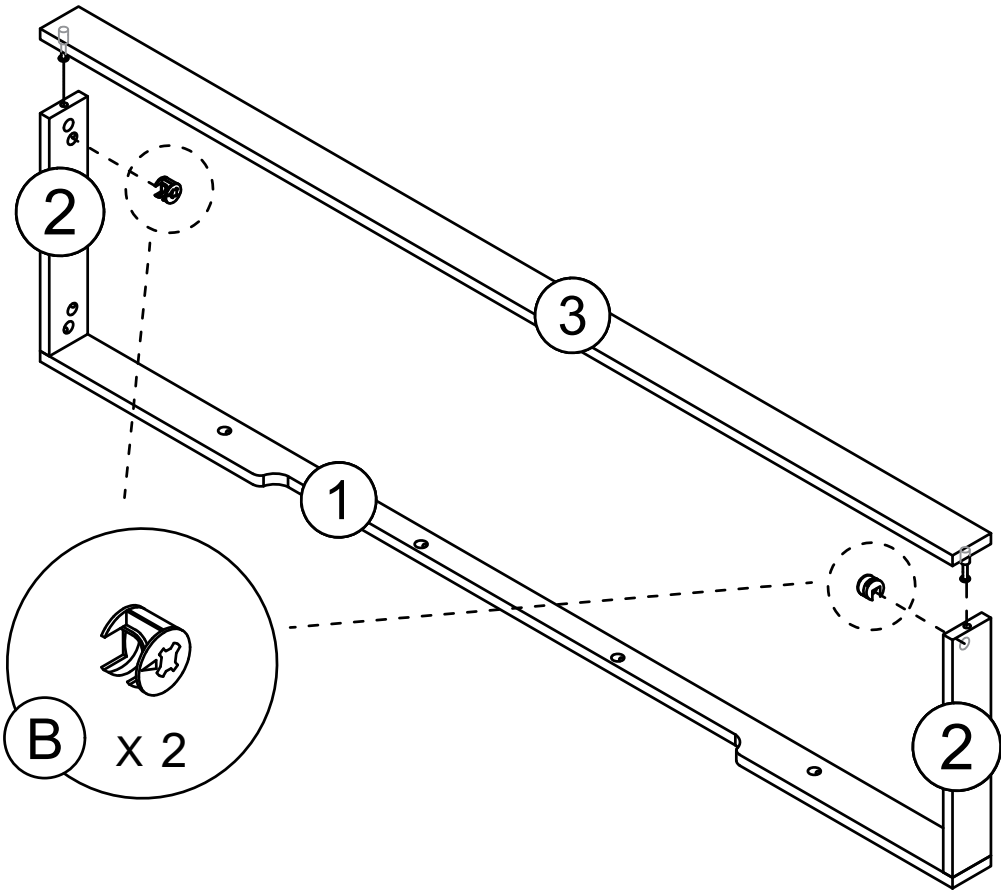

Step 4

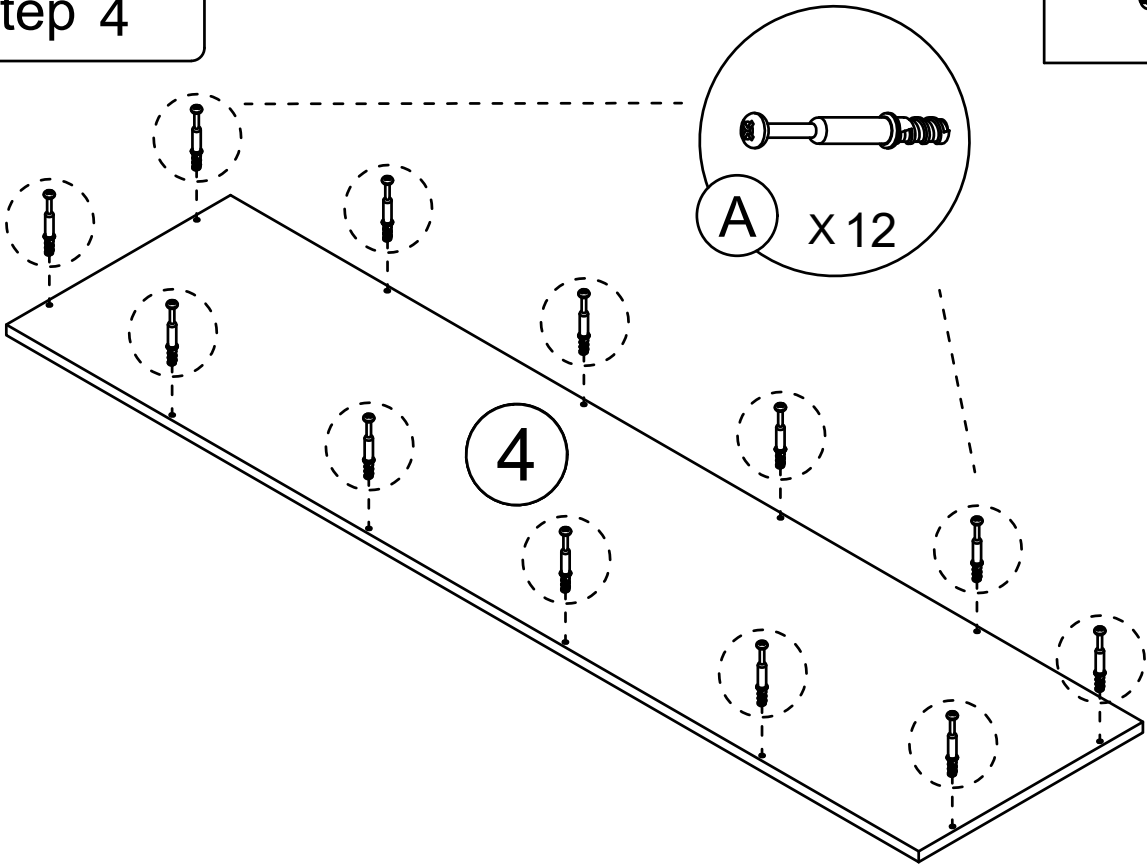
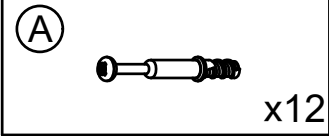

Step 5

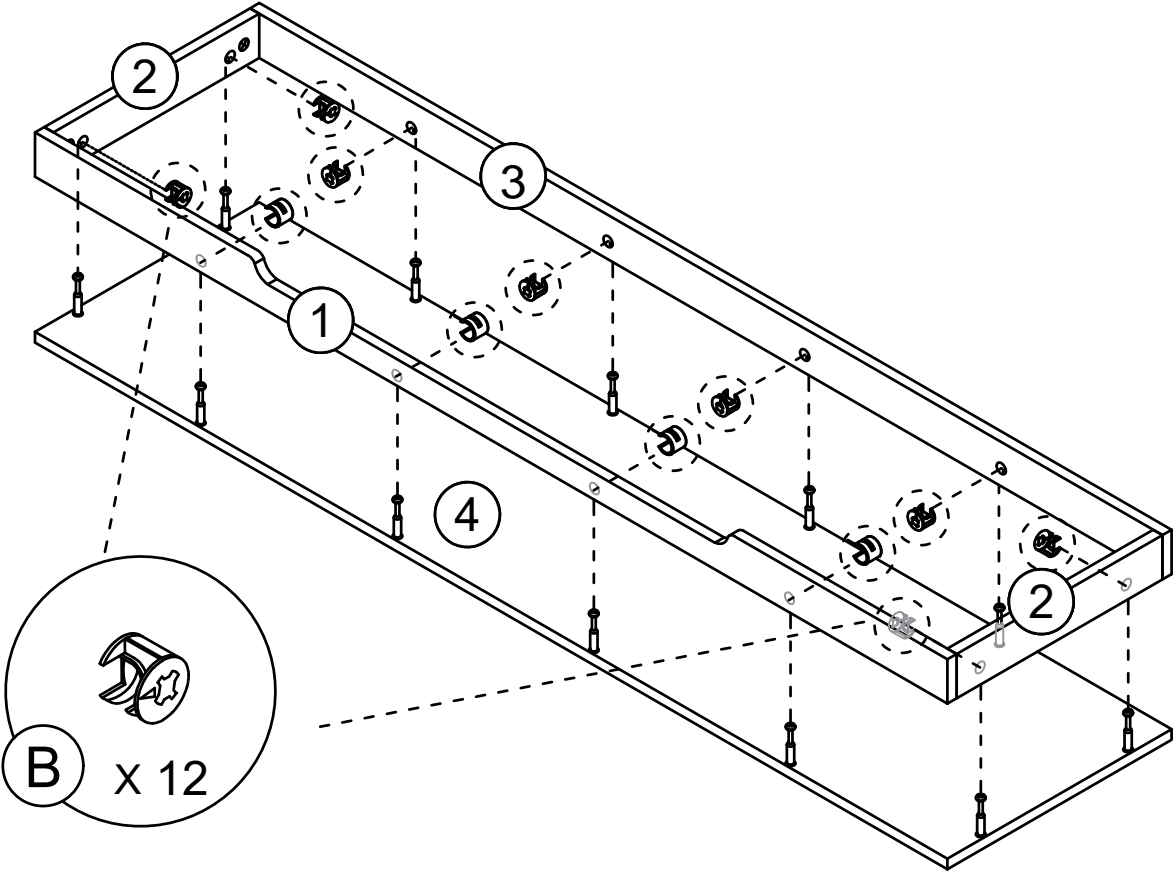

Step 6

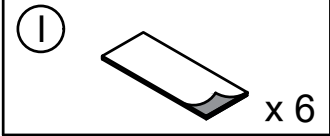

Tear off release paper and stick the black foot pad on the board

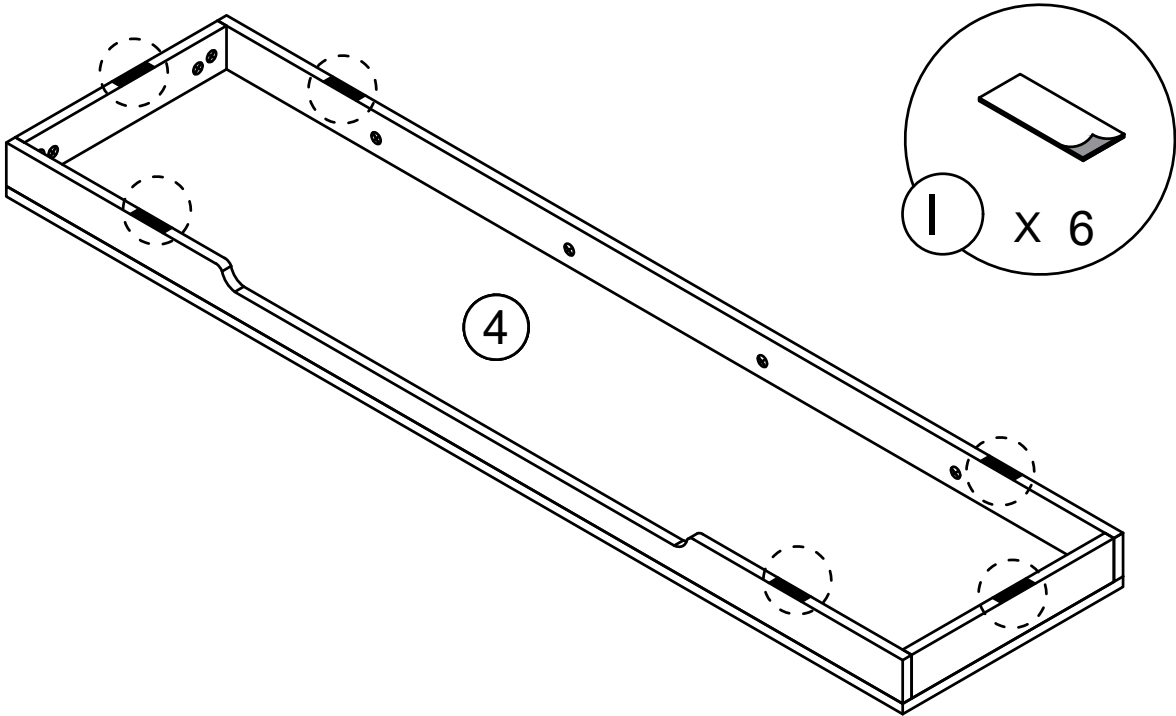

Step 7

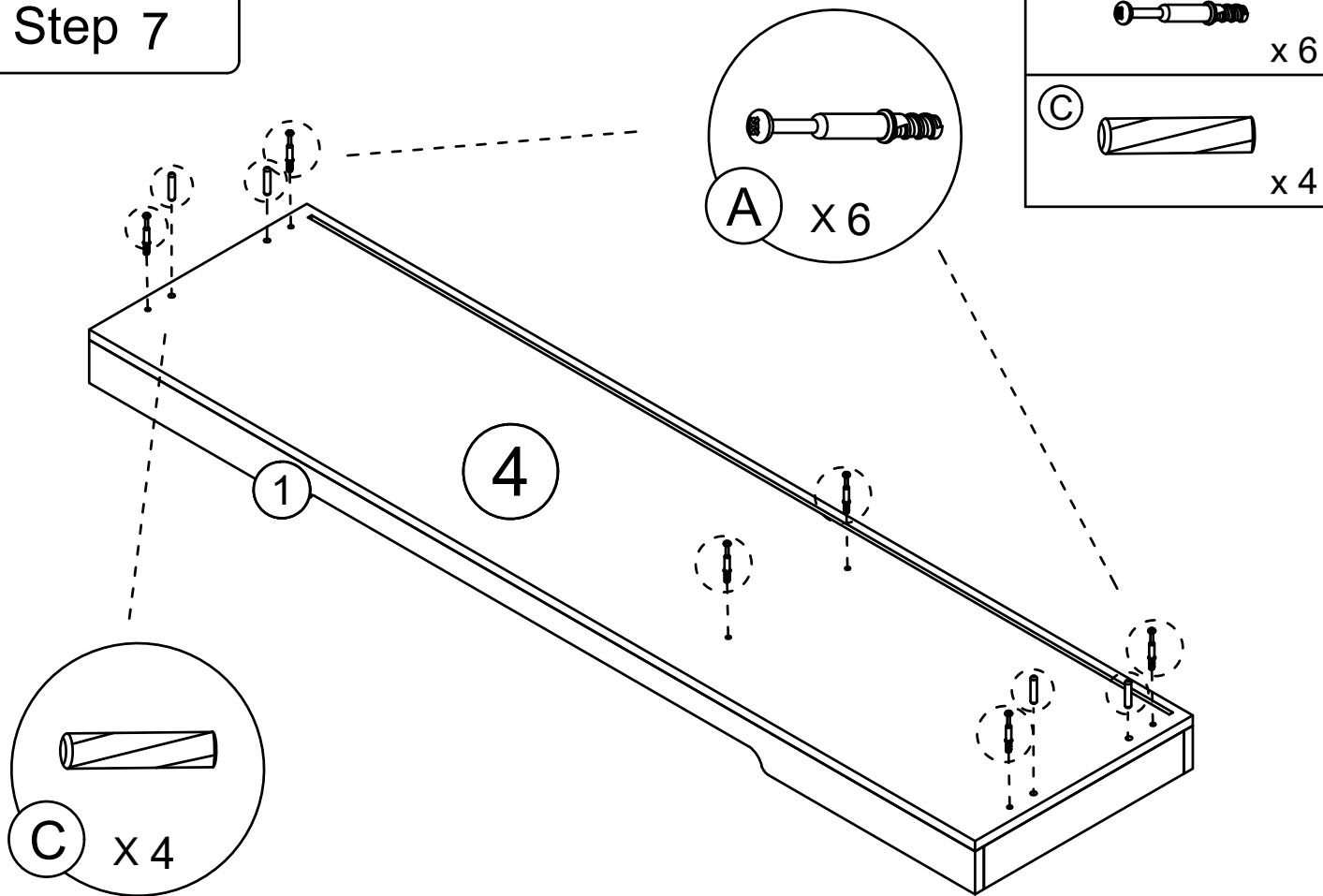

Step 8

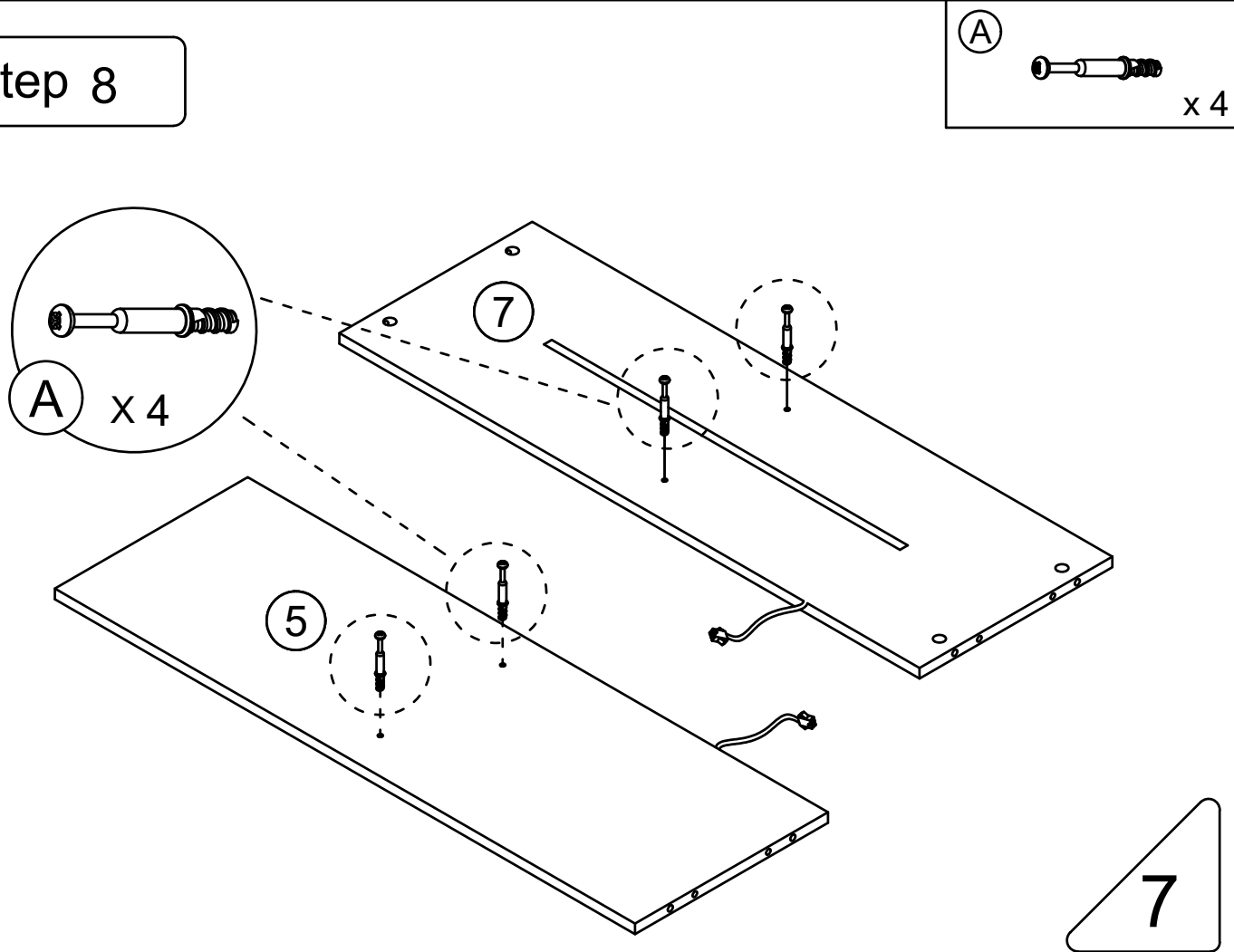

Step 9

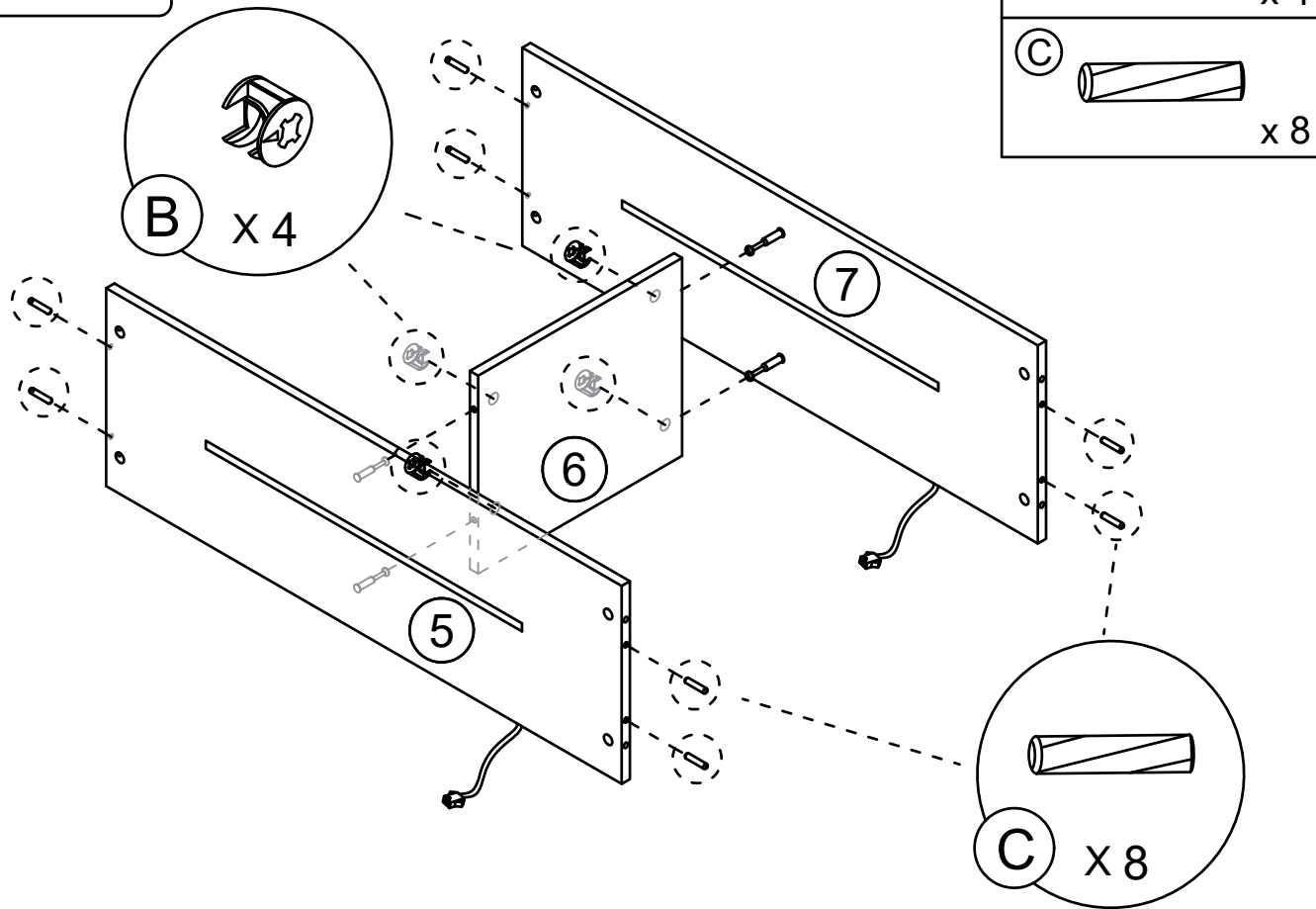

Step 10

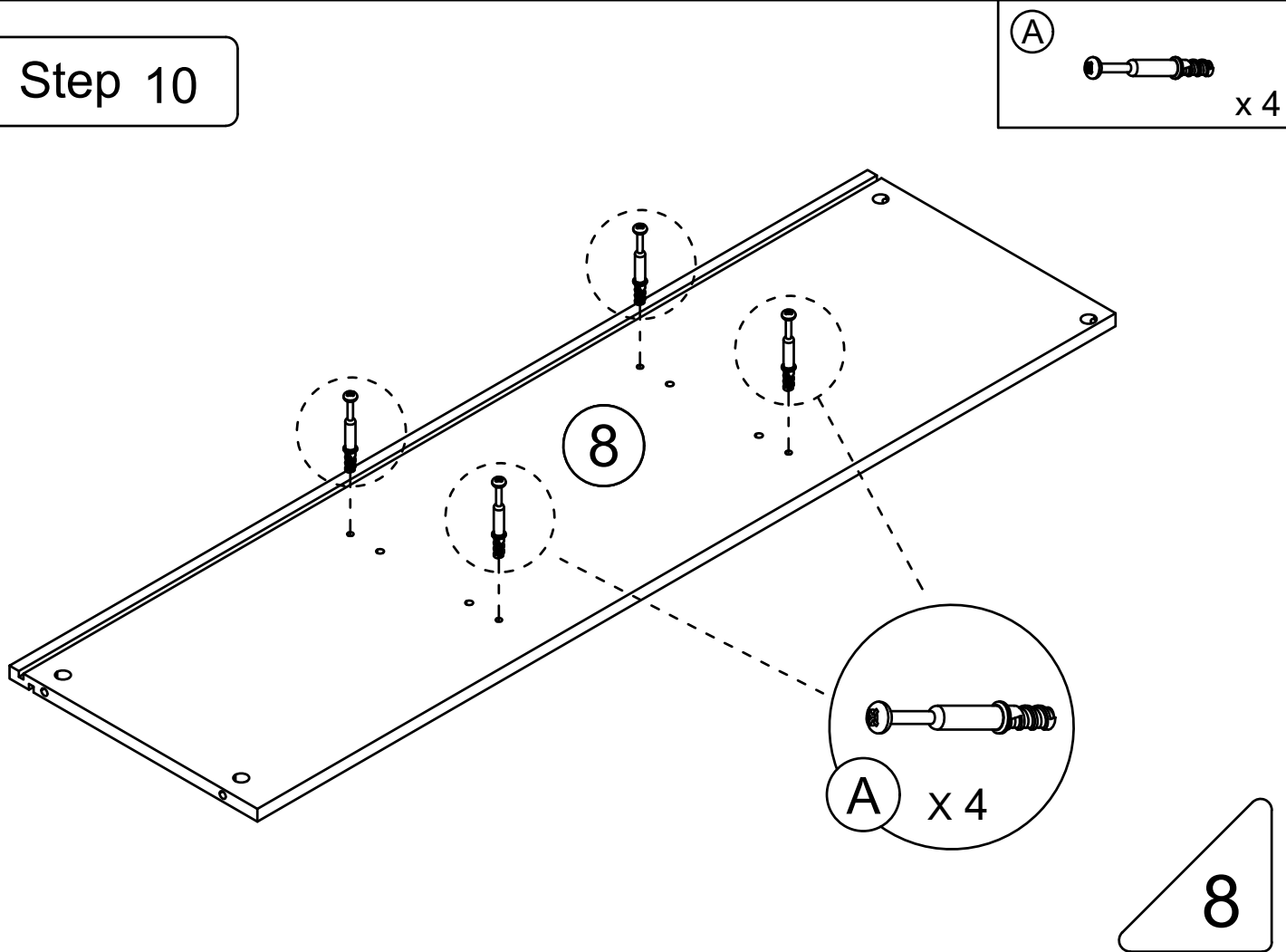

Step 11

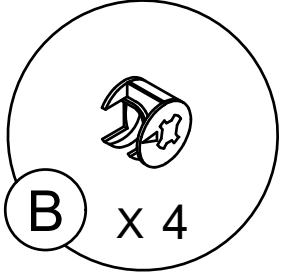
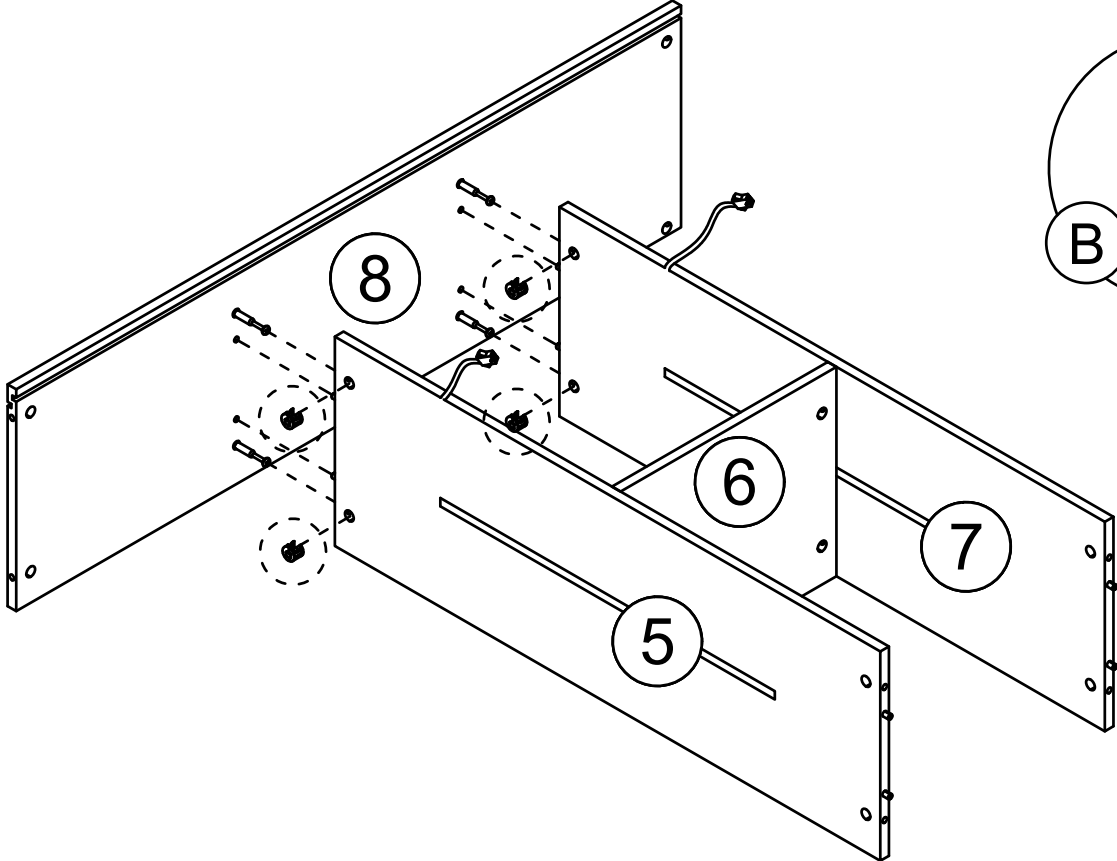

Step 12

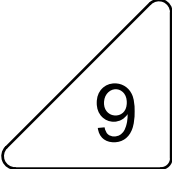
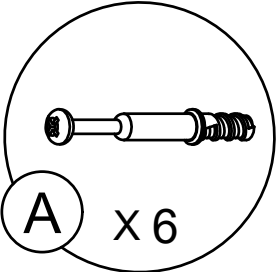
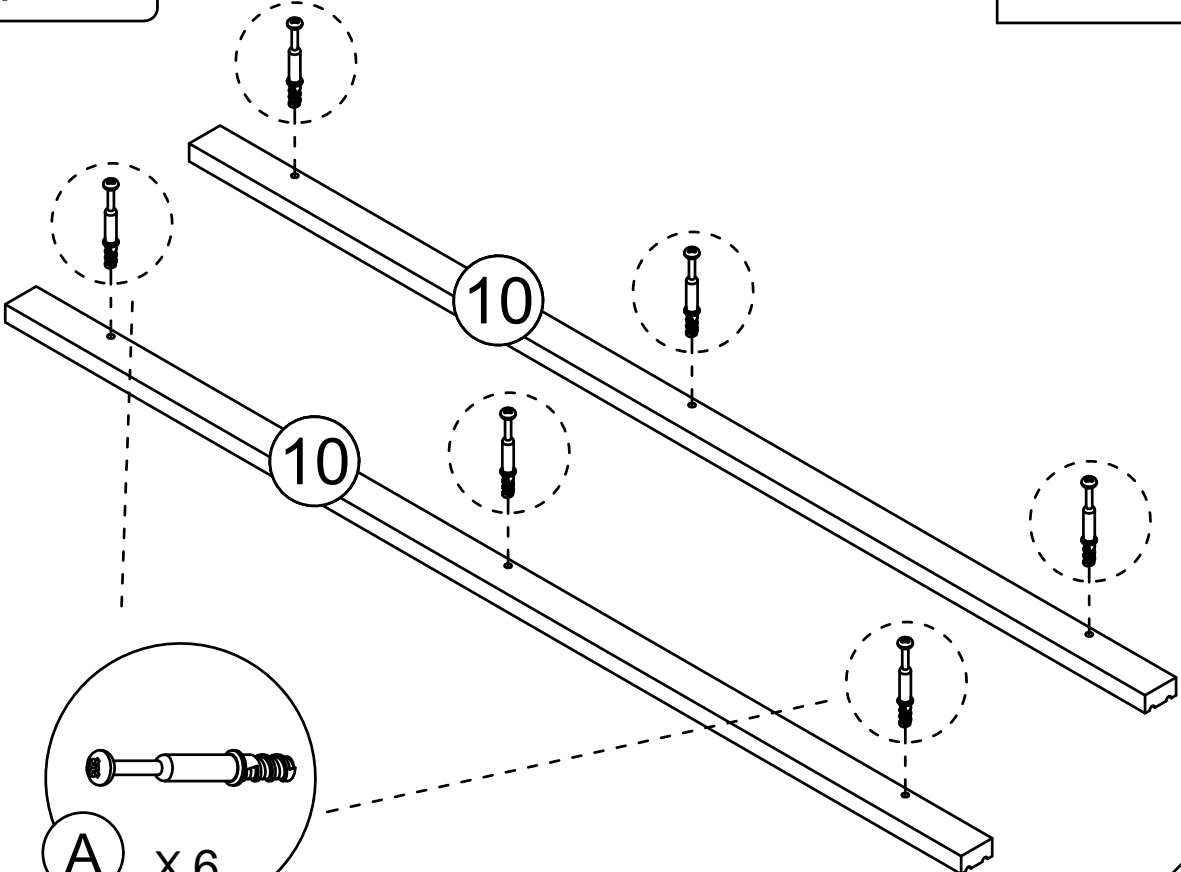
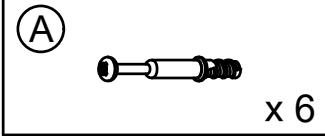

Step 13

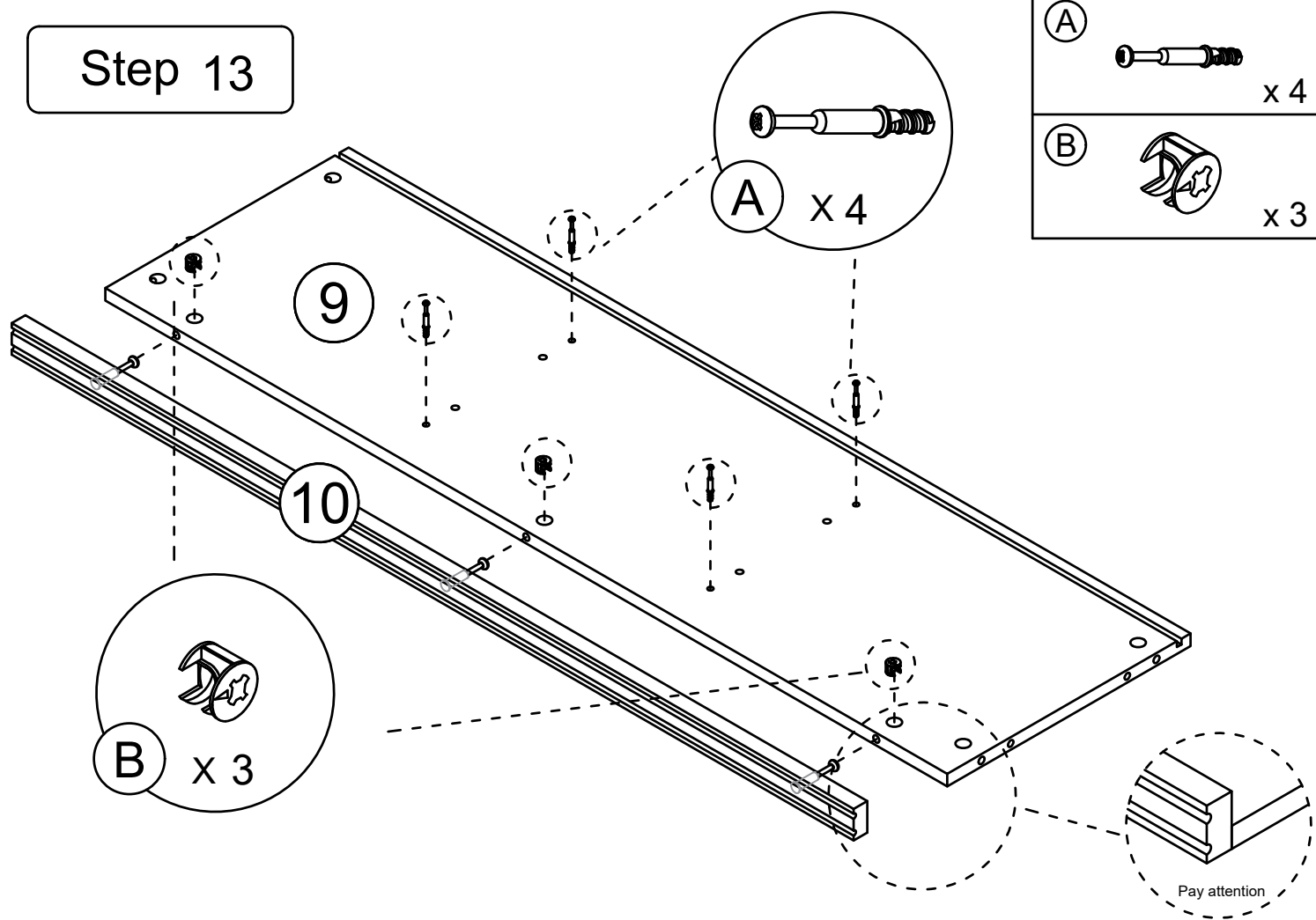

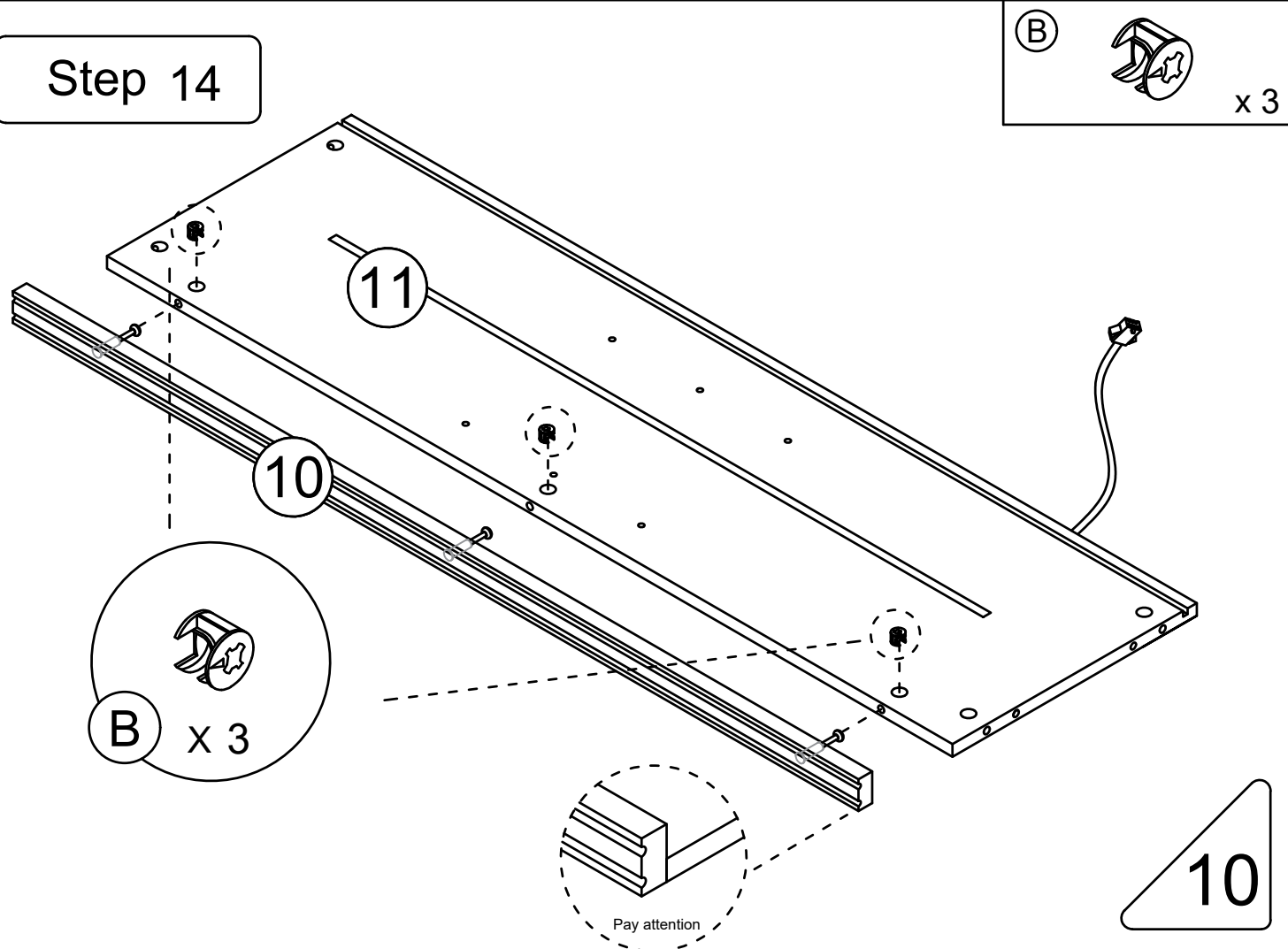

Step 14

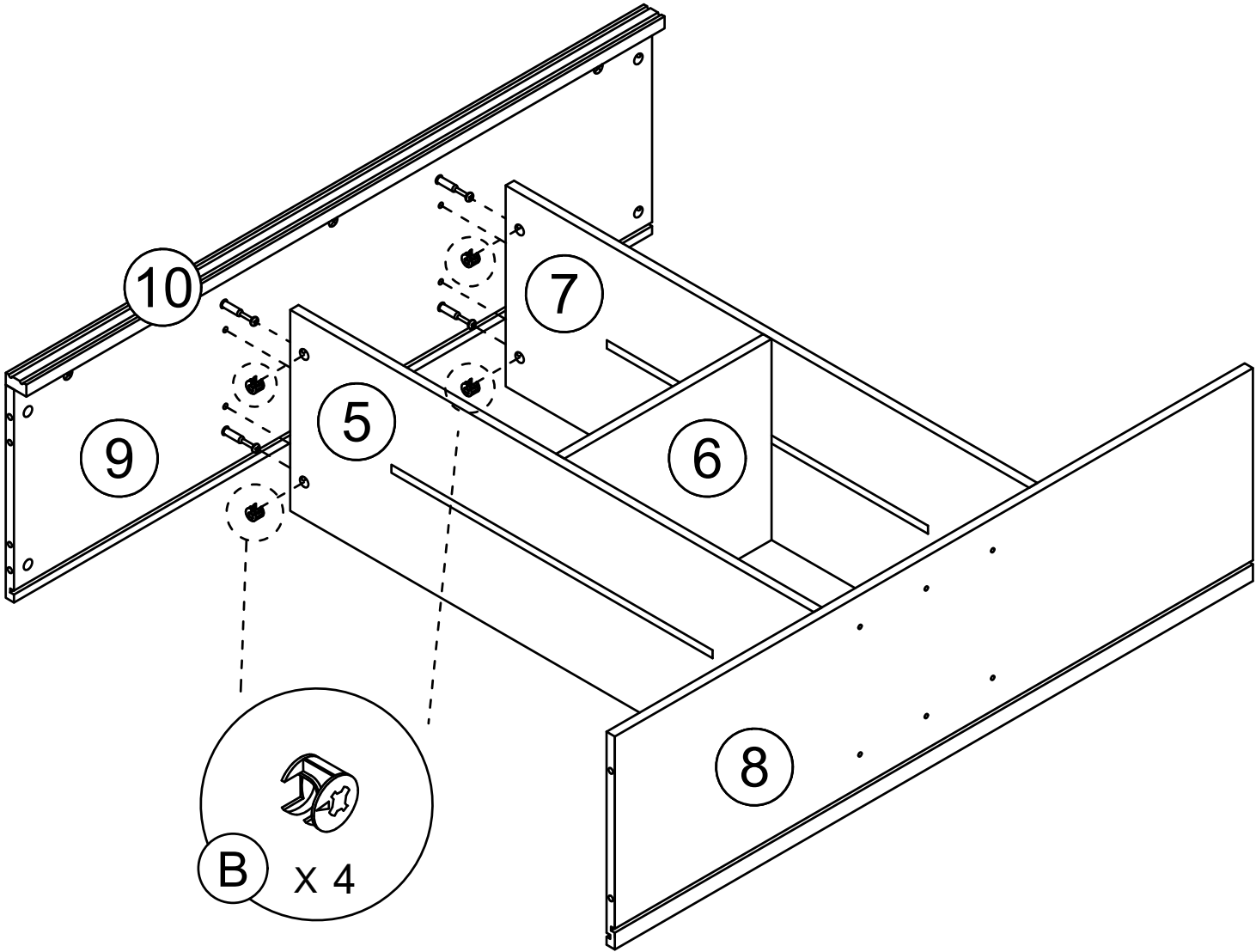

Step 15

(B)  x 4



(B)  x 4

Step 16

(B)  x 4

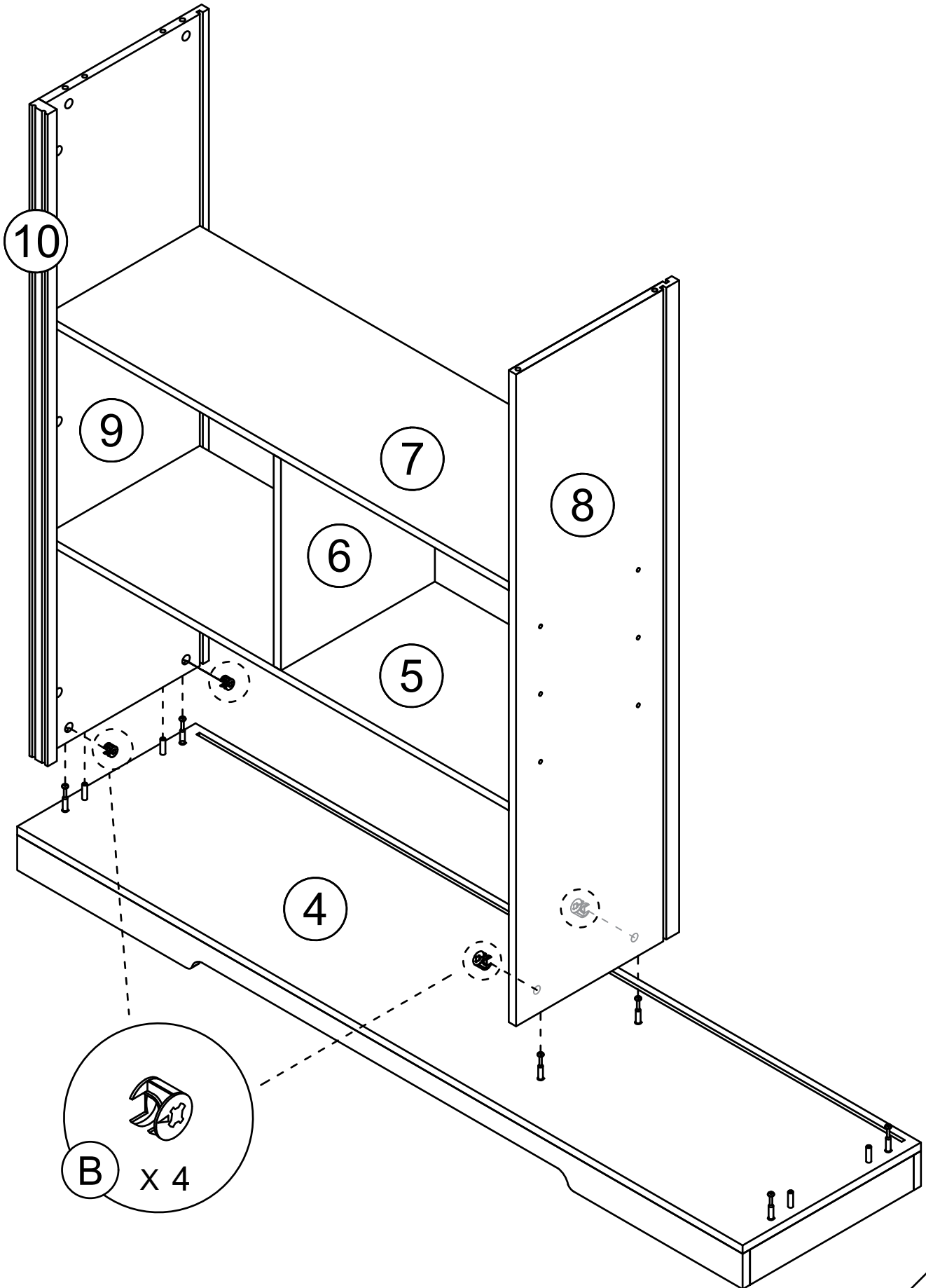

(B)  x 4

Step 17

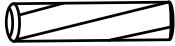
- (B)  x 2
- (C)  x 4

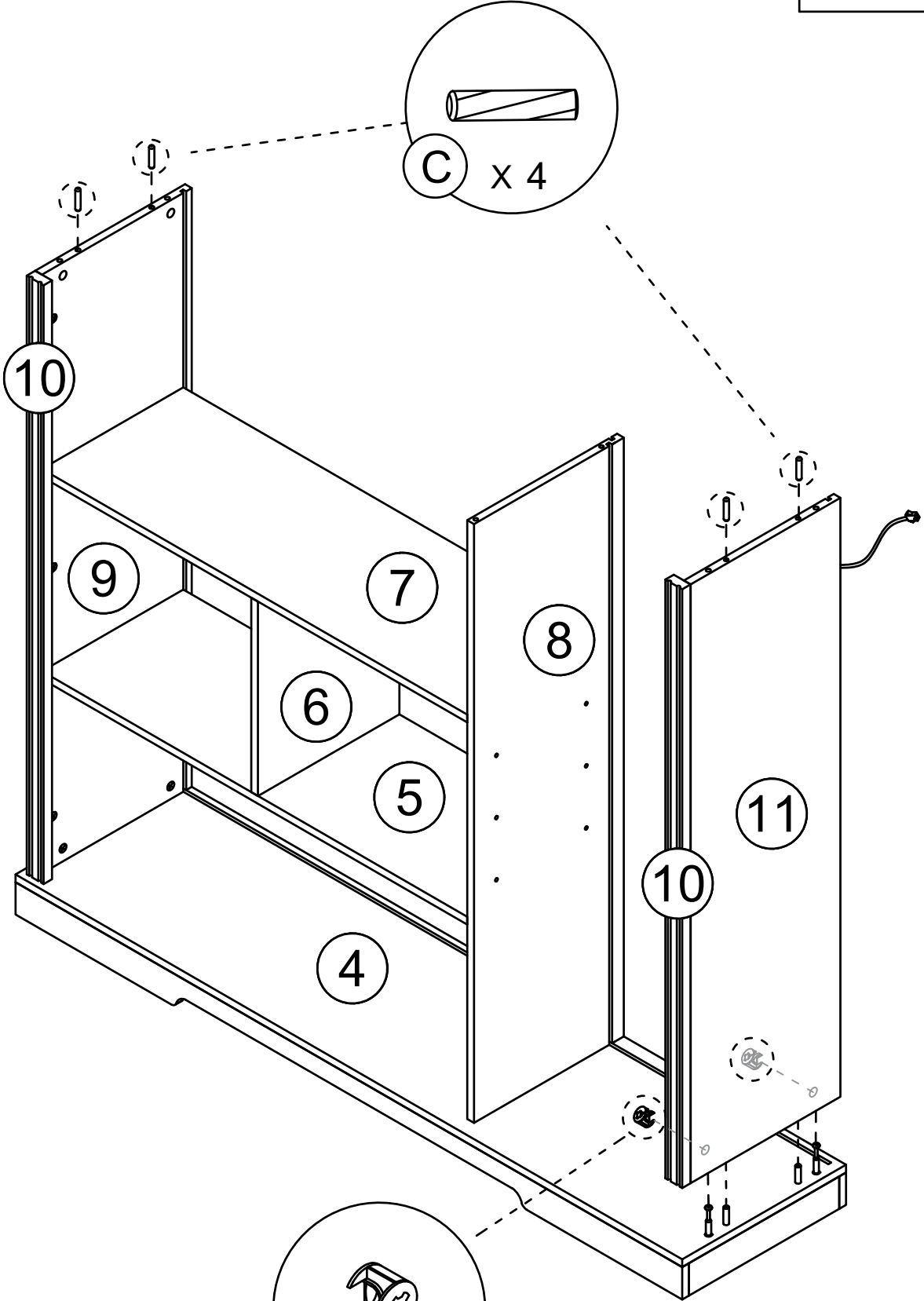

- (B)  x 2

Step 18

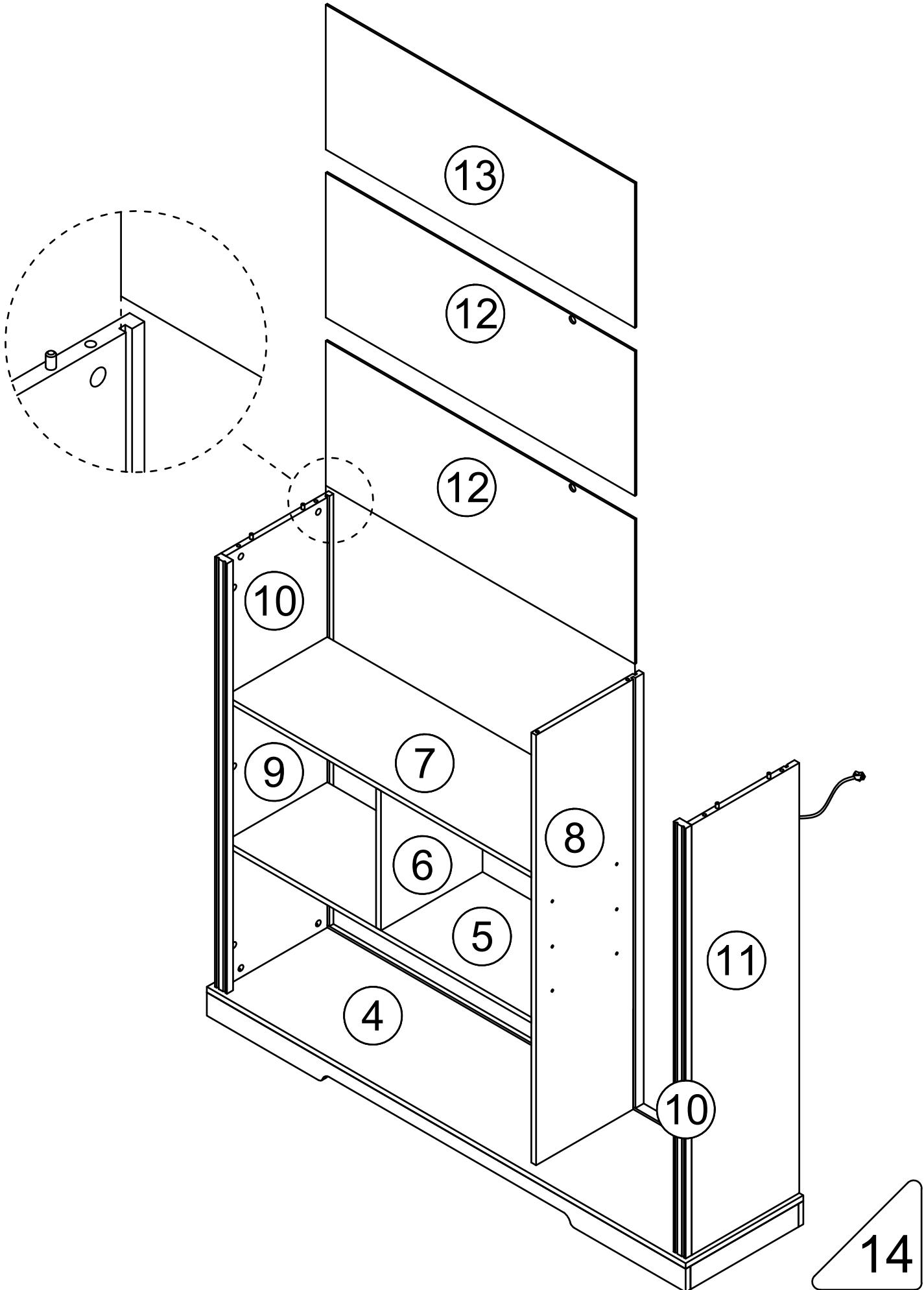

Step 19

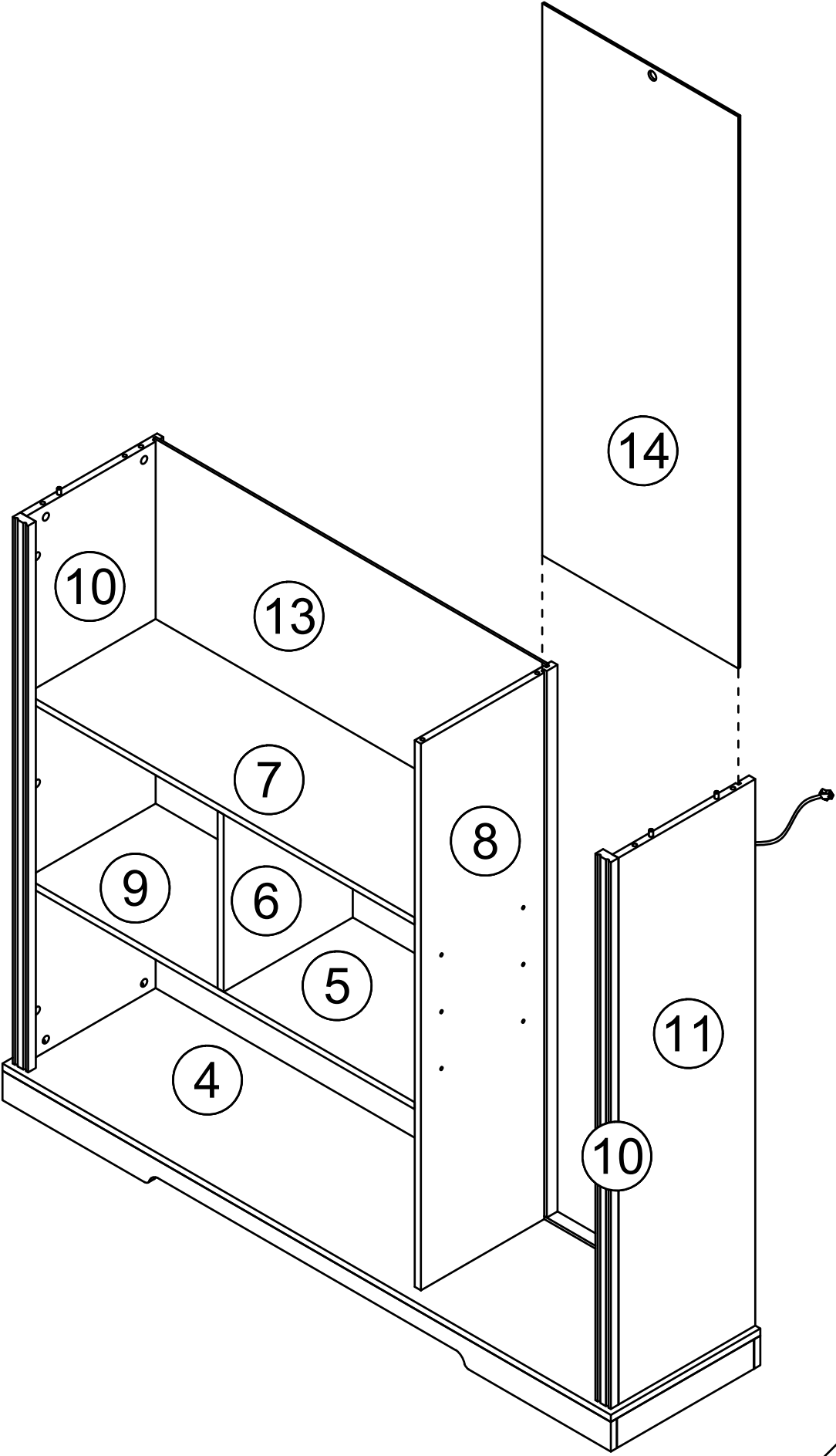

Step 20

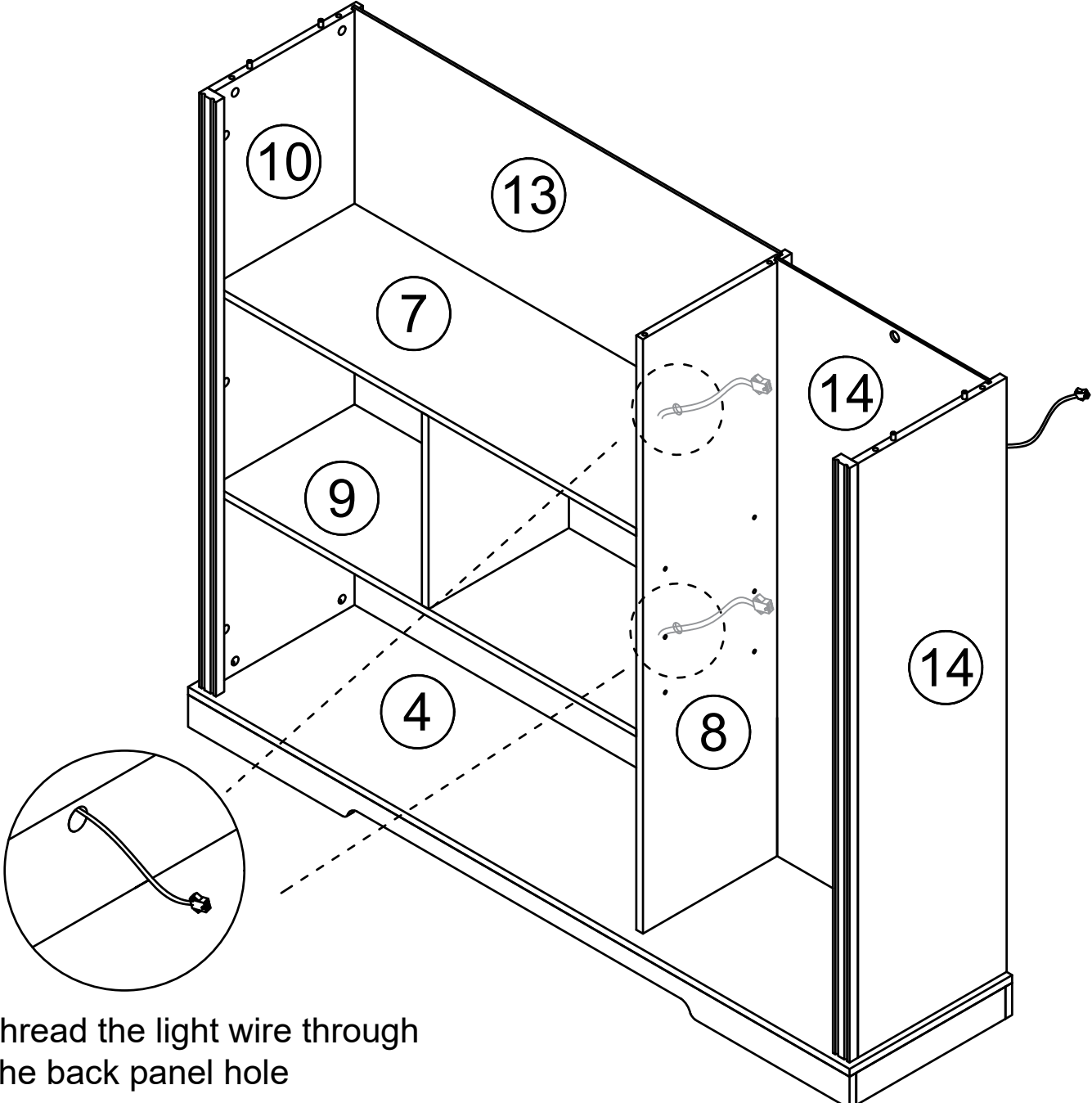

Thread the light wire through the back panel hole

Step 21

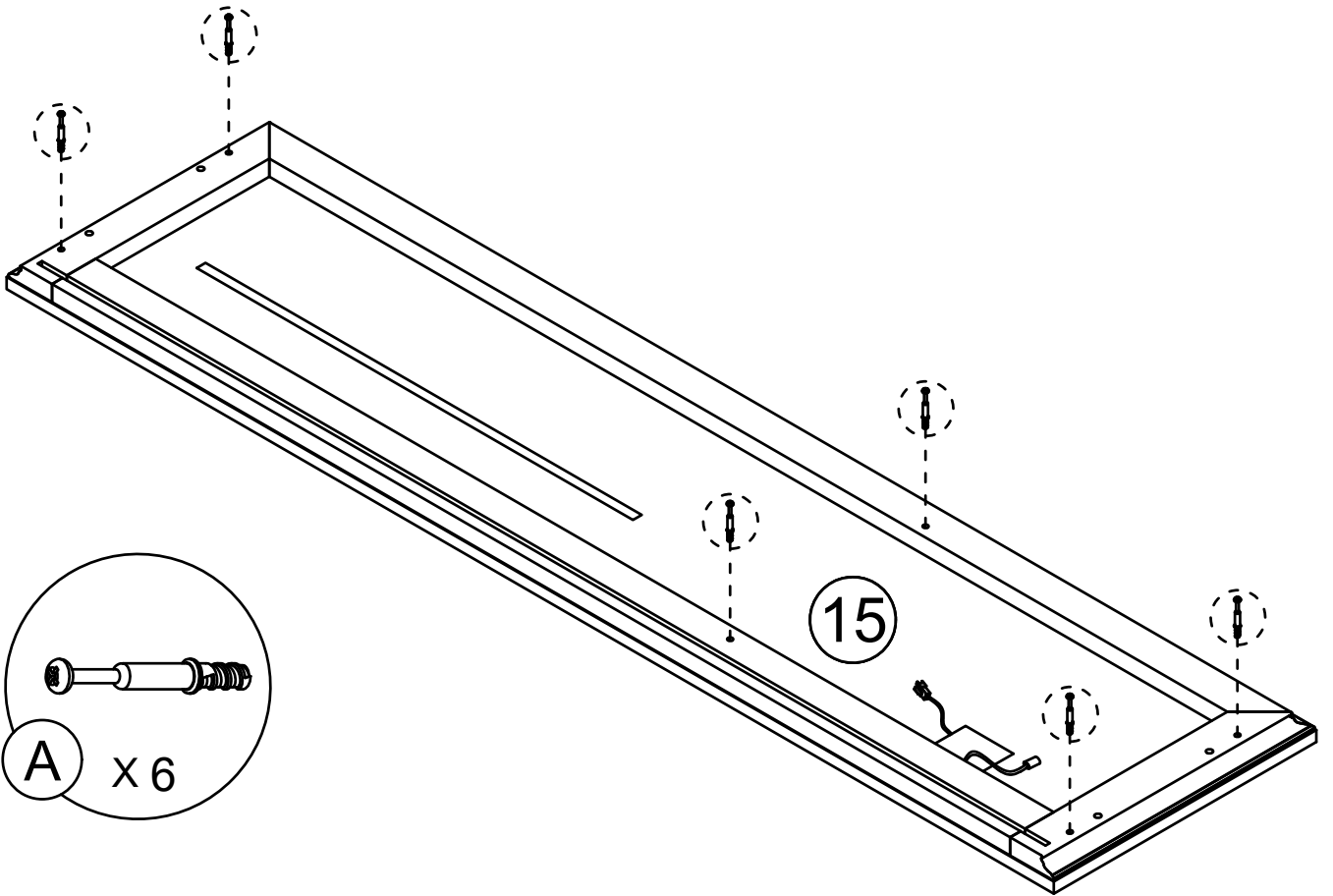
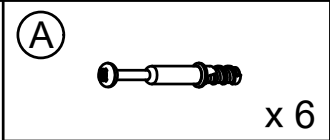

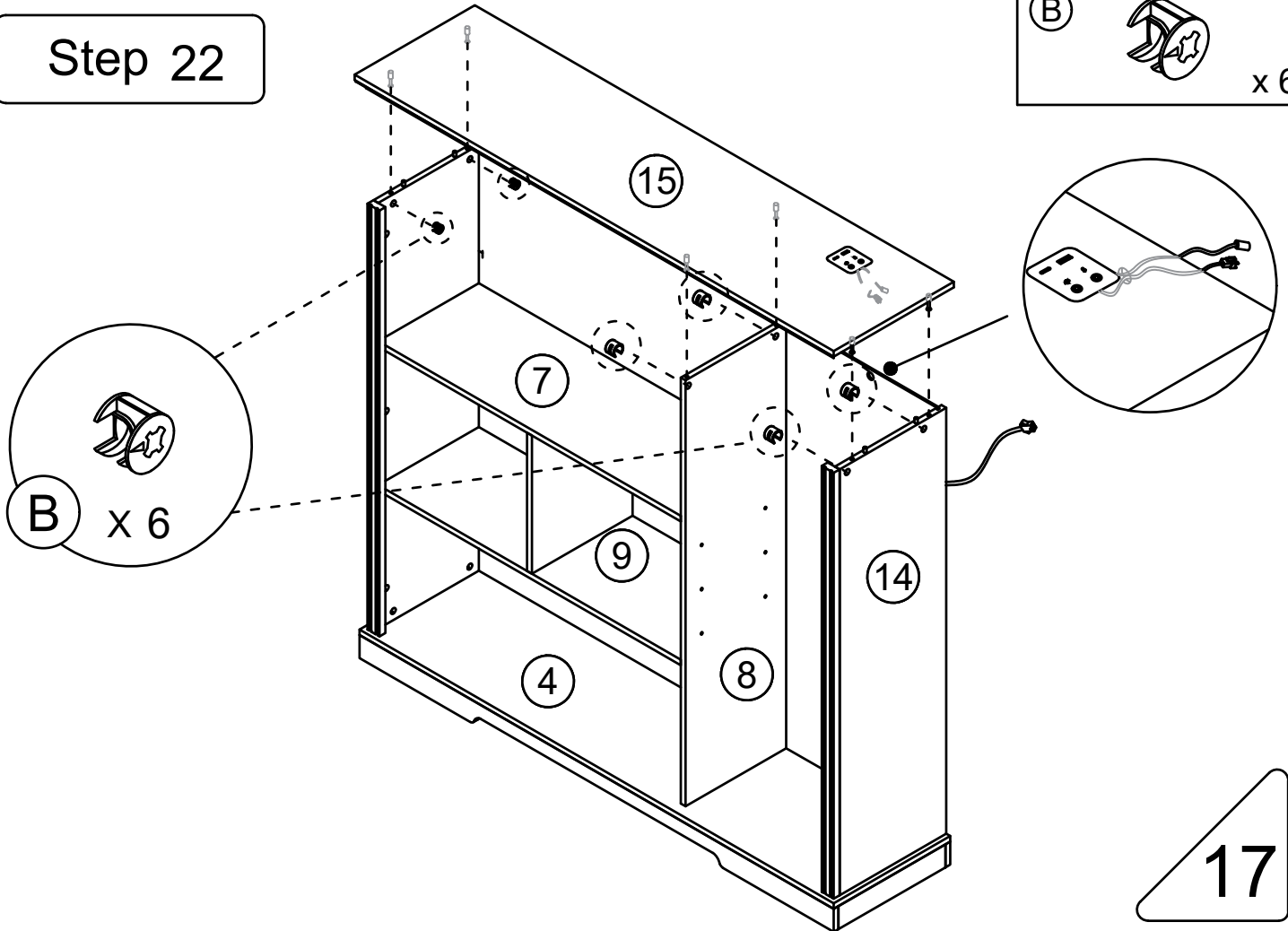

Step 22



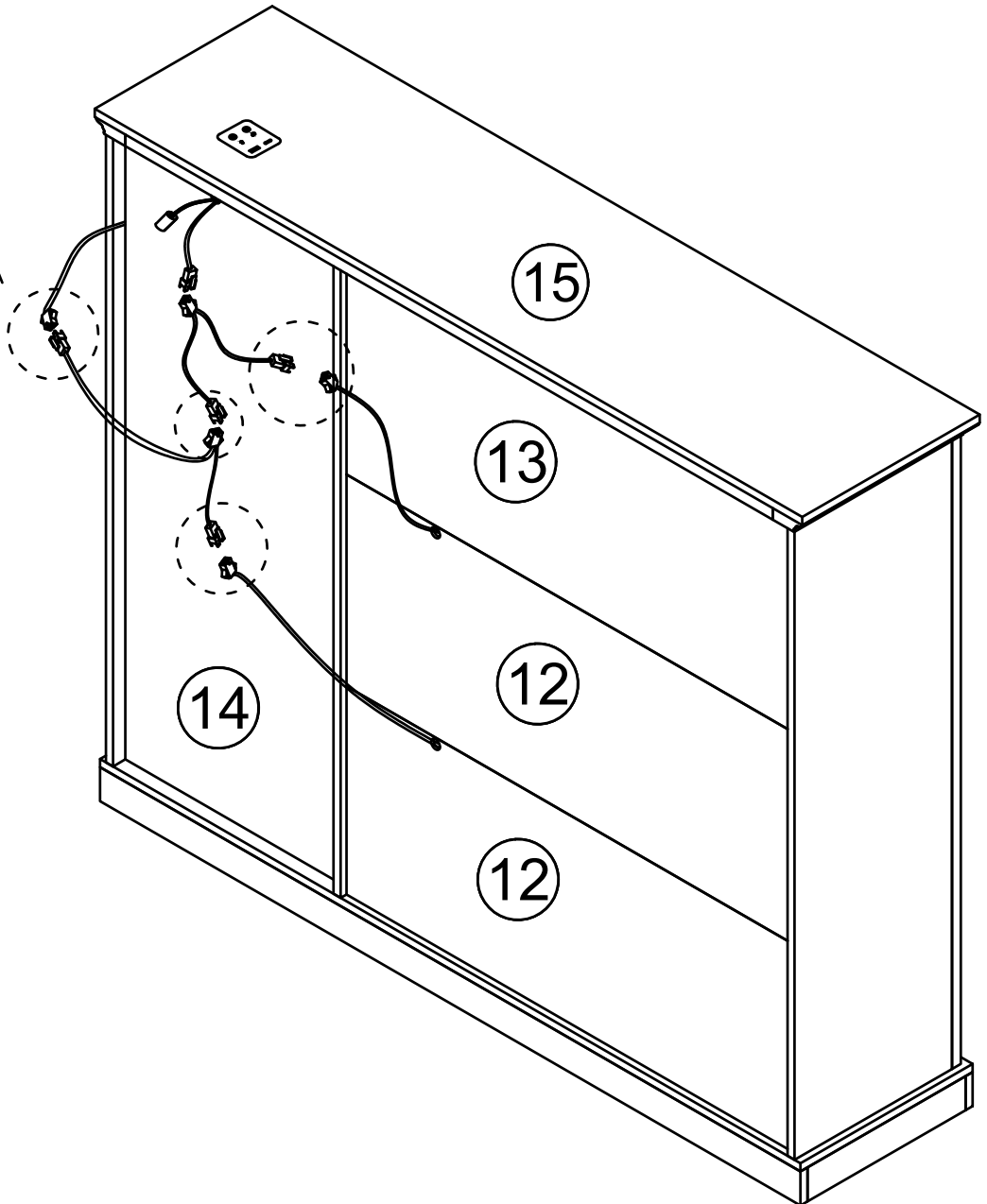
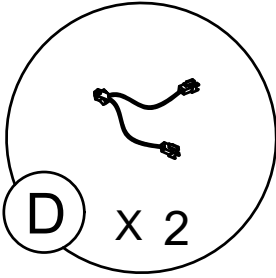
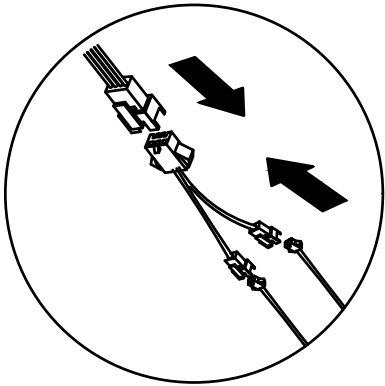
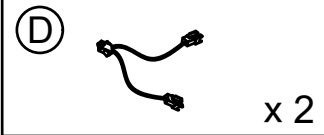

Step 23



Step 24

(E)  x18  x18

(E)  x18  x18

15

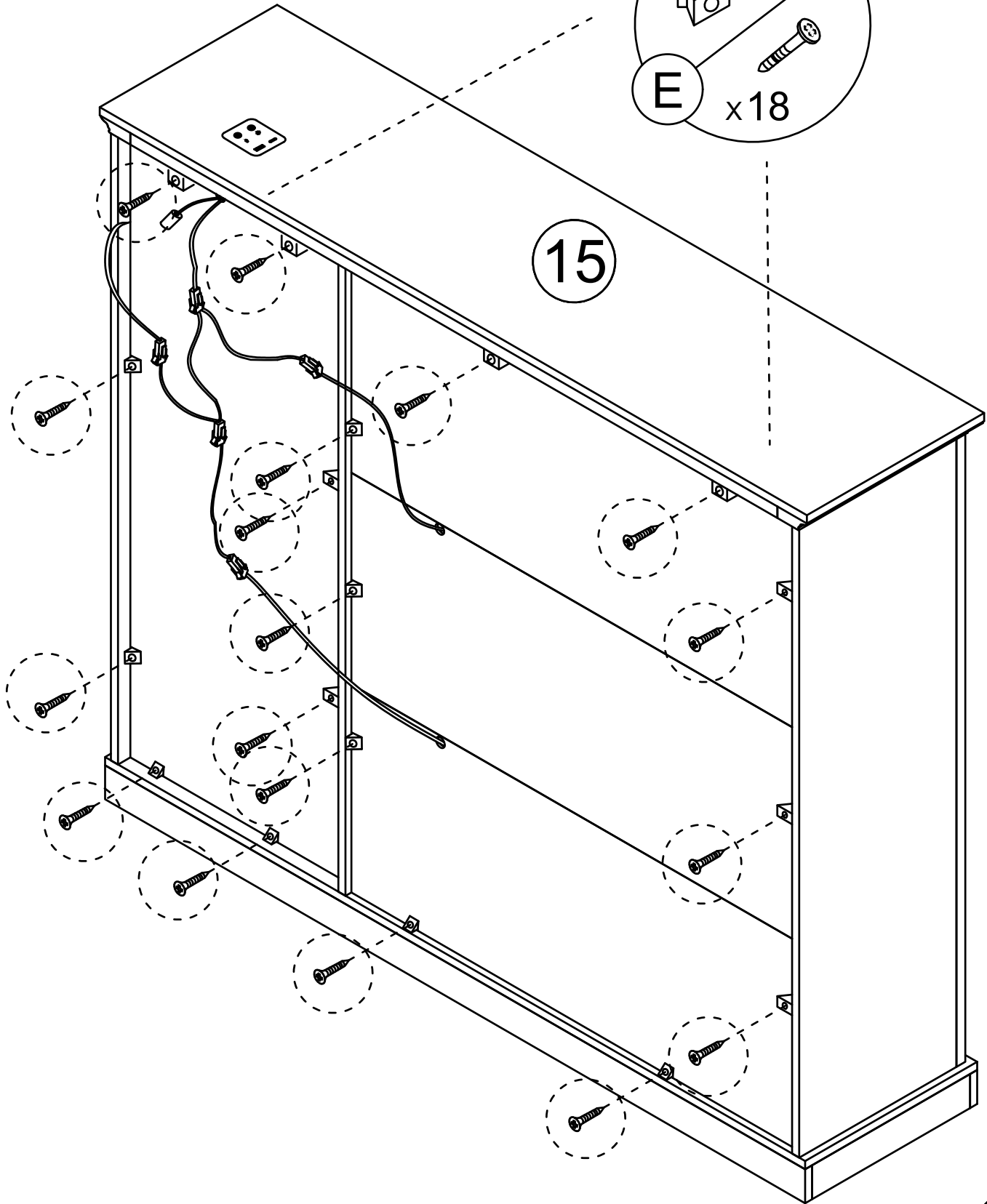

Step 25

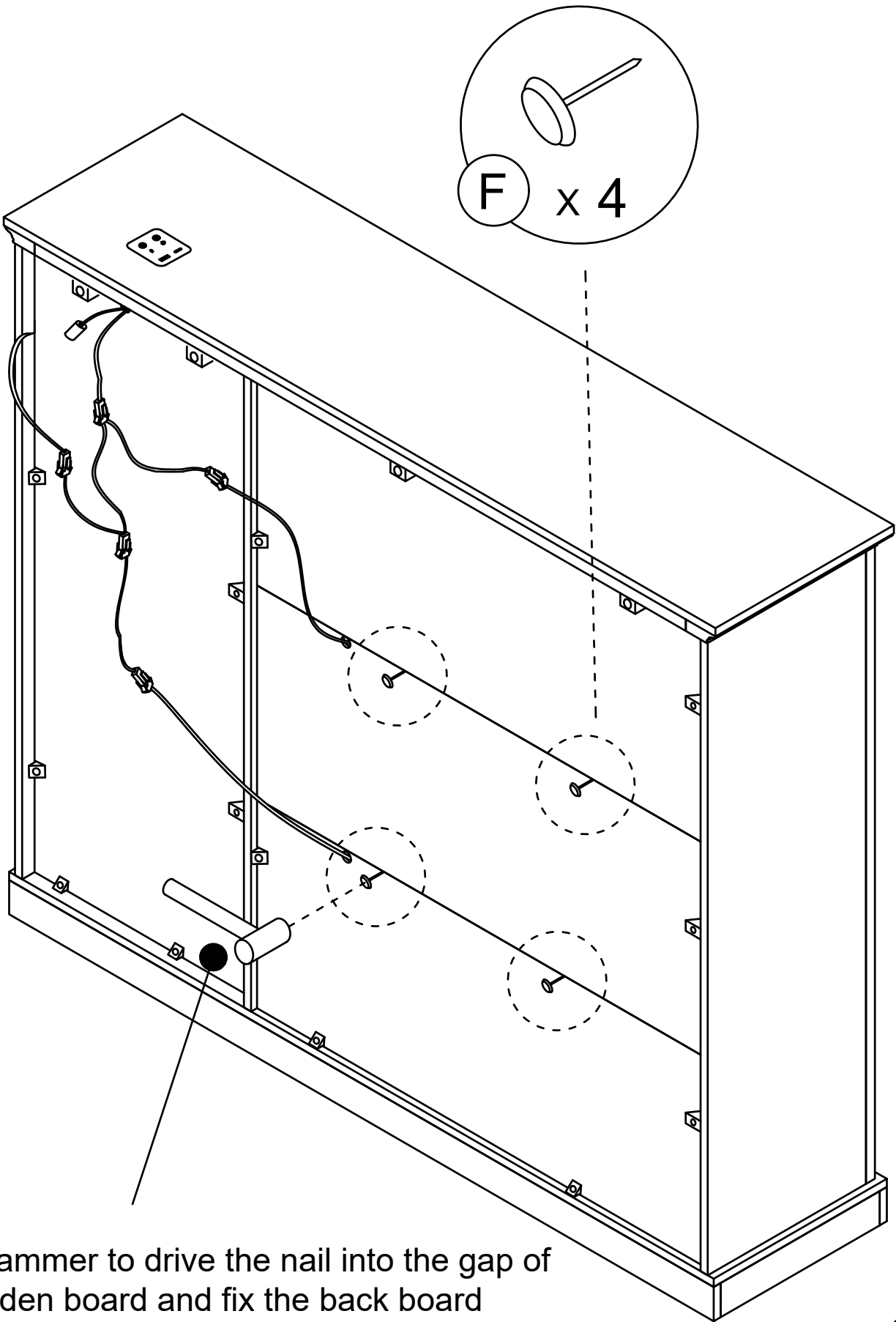
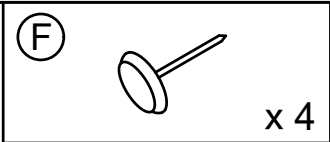

Use a hammer to drive the nail into the gap of the wooden board and fix the back board

Step 26

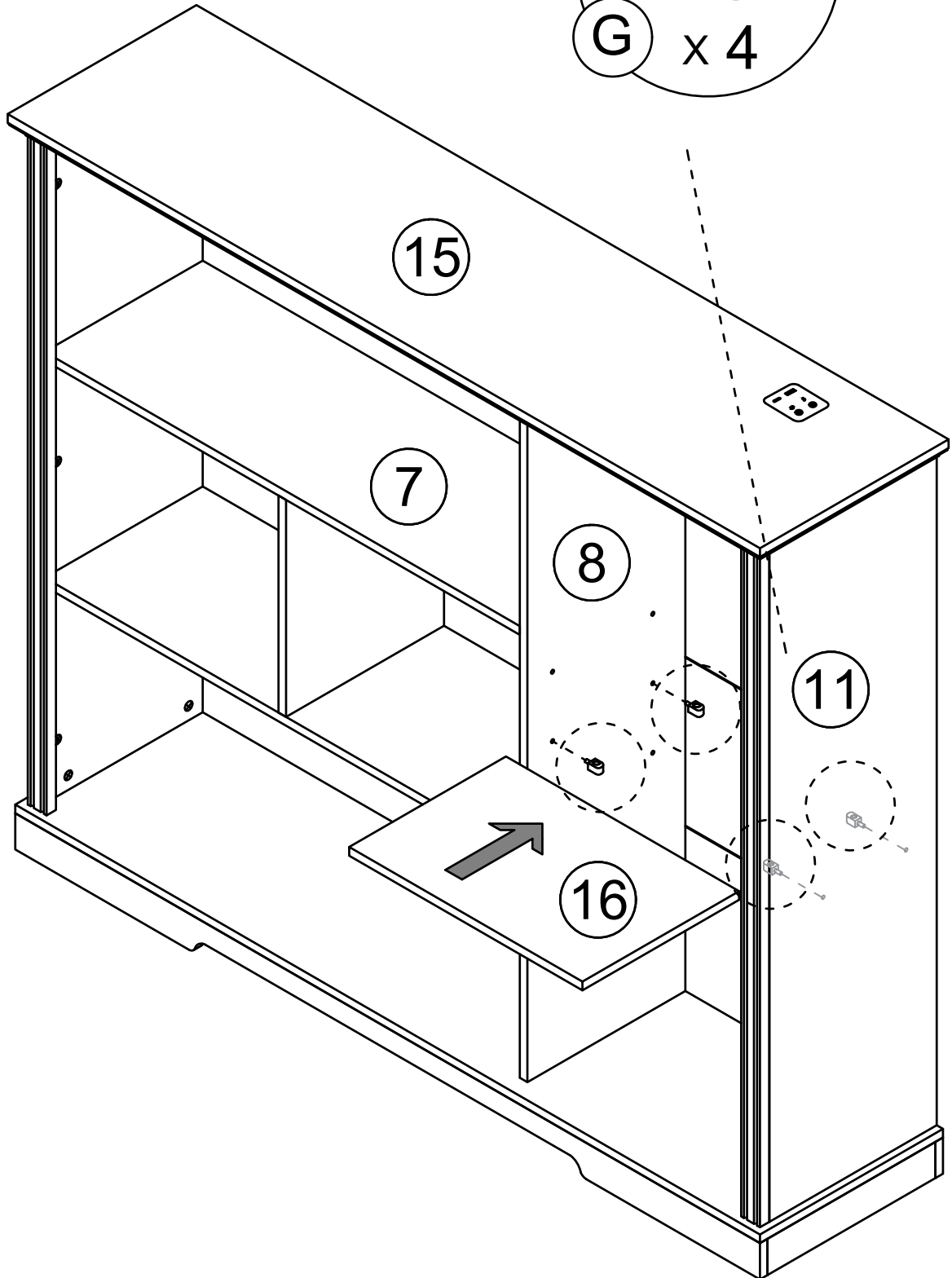
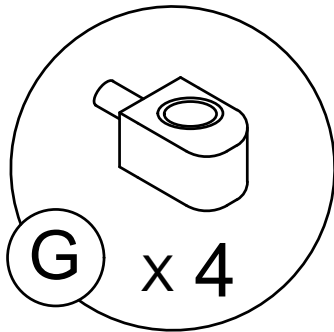
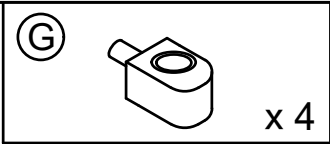

Step 27

Wall Mount

+

Wall

Wall

Drill the hole after measuring and marking position.

Wall

Wall

H x2 x2

x4 x2

x2

Install as required

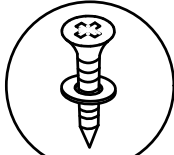
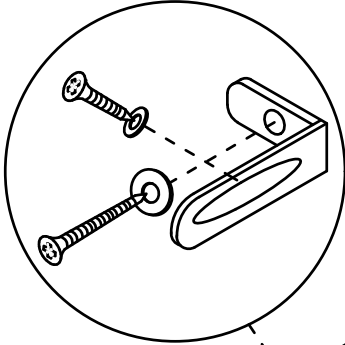

3.5x14mm

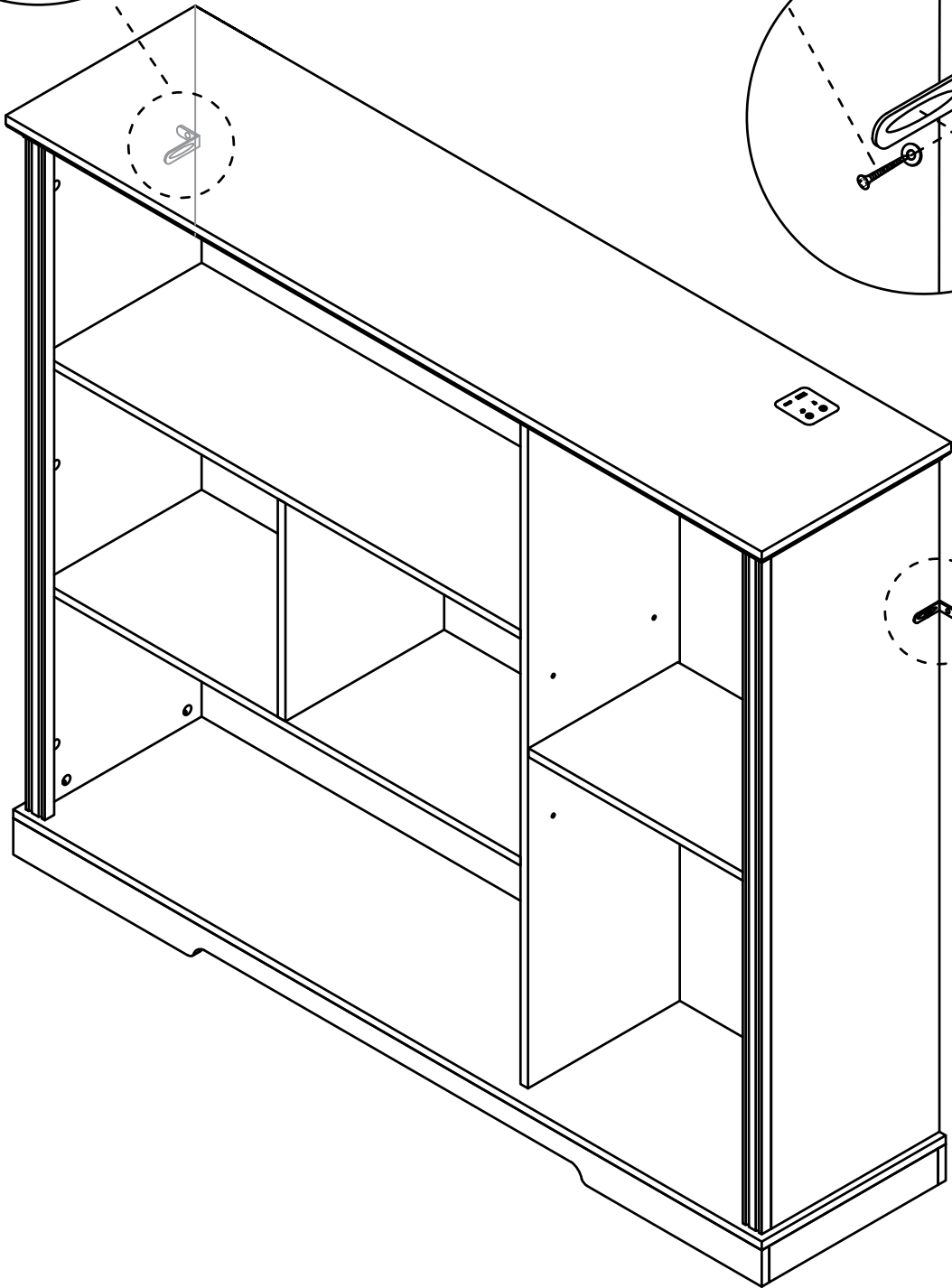
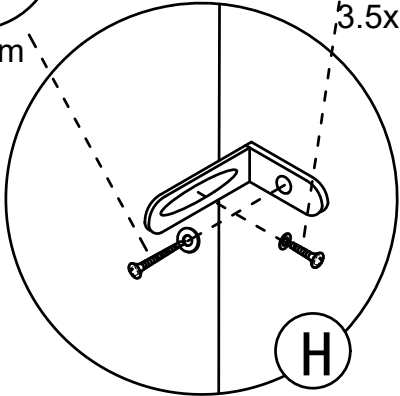

Step 28

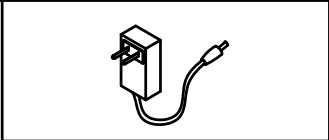

wall

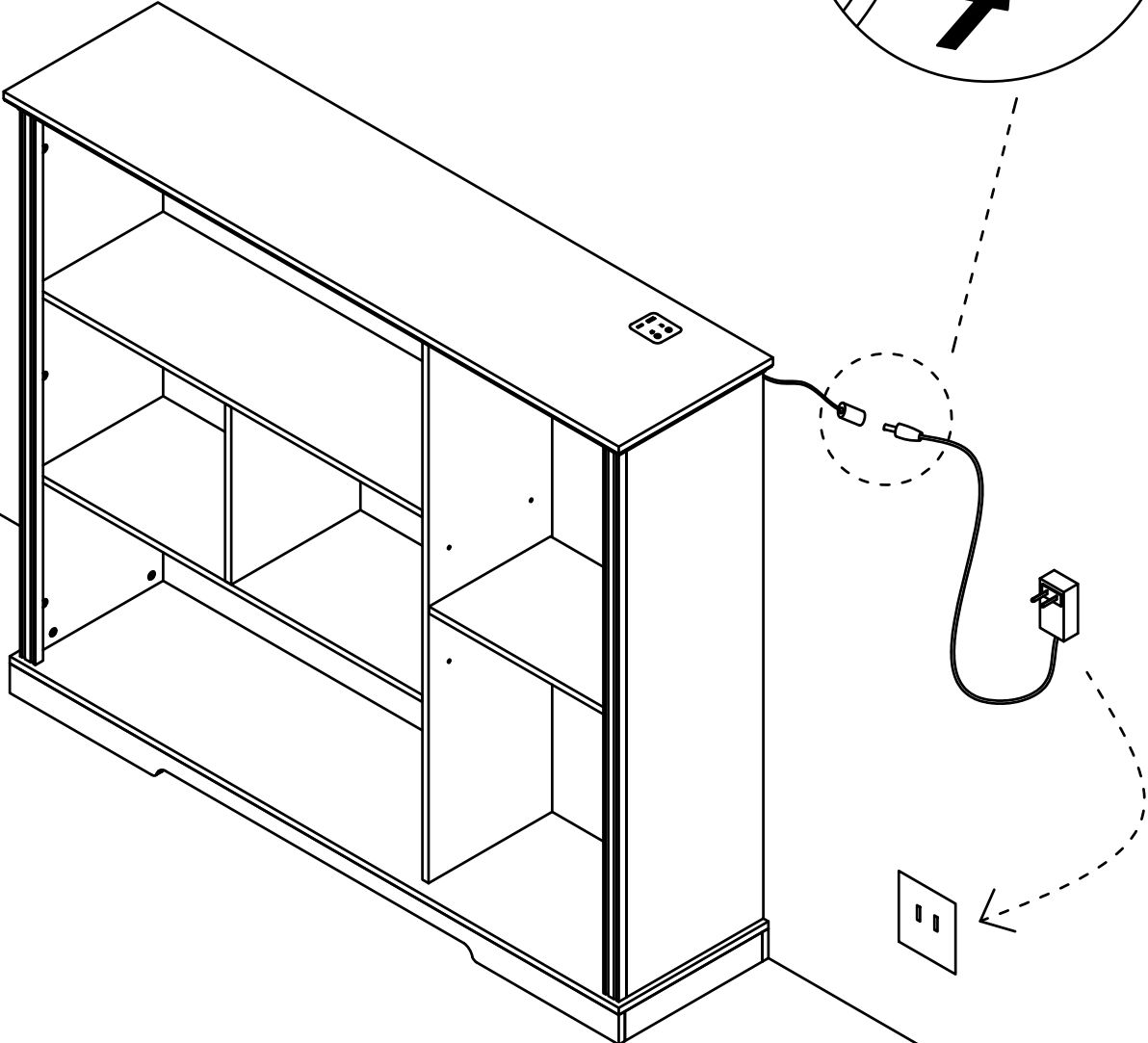
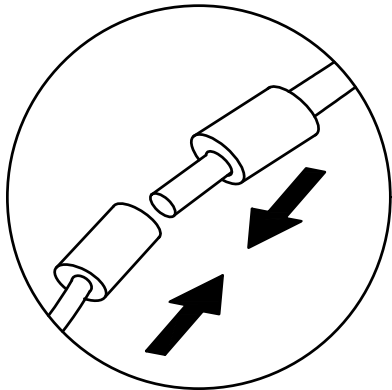

User's Guide

Thank you for purchasing this product. To use this product, please plug it into a 12V DC power supply. Please use if the product works normally after connecting to power.

Introduction

The box is an intelligent controller. It has 1 USB port and 1 type-C port and can distribute the current output up to 5V DC-2A. With 2 touch buttons, it can turn ON/OFF the light, change light colors, and adjust the light luminance.

Product Show

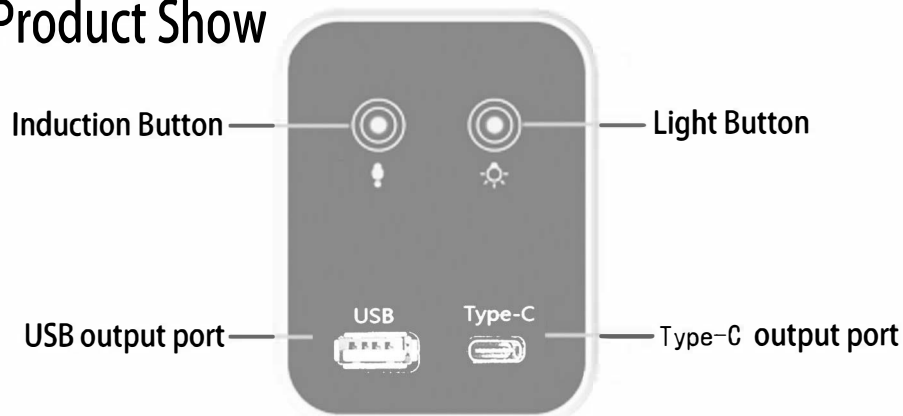

ATTENTION PLEASE

1. If there is no touch response suddenly, Re-plug the power to reset the touch static electricity.
2. If bubbles appear on the panel, remove the protective film.

Operation



This touch button is used to turn on/off, change colors, and adjust brightness.

A. Short touch -> lighting on -> short touch -> change light color -> short touch -> change light color -> short touch -> lighting off. B. Long touch -> adjust the luminance



This touch button is used to turn on/off the induction function.

A . Short touch to turn on the induction function. It can auto-turn on the light when people are close to the controller in 1 meters. It can auto power off the light when the body is far away from the controller after 30 seconds.

B . Long touch to turn off the induction function.

C . Note: When you touch the light button to change the light modes, the induction function will automatically turn off. It is best to turn on this function after selecting the light color and adjusting the brightness you want.