

NOTES:

1. TO INSPECT ASSEMBLY, FOLLOW FIRST ARTICLE AND IN PROCESS INSPECTION SHEET.
2. PACK THESE ITEMS IN A PLASTIC BAG.
3. HANDLE IN CLOSE POSITION.
4. INSTALLATION TORQUE 11-14 LB-FT.
5. INSTALLATION TORQUE 4-6 LB-FT.
6. APPLY LOCTITE 680.
7. APPLY LOCTITE 242

BILL OF MATERIAL (CURRENT LEVEL)

ITEM	PT/ASSY	DESCRIPTION	TYPE	QTY.
1	12922	VALVE BODY, WALL-END	PART	1
2	11309	FLANGE, MOUNTING	PART	1
3	92223	SCRW, #8 X 2-1/2 PHL FLT HD SS	PART	4
4	92231	SCRW, 1/4-20 X 1/4 SKT HD CUP PT SS	PART	1
5	2-553	LOWER ARM ASM, CONTEMP	ASSEMBLY	1
6	20-337	UPPER ARM ASM, CONTEMP	ASSEMBLY	1
7	1-325	W/S CARTRIDGE FRICTION - COLD	PART	1
8	1-436	CARTR 3/8 COLD 1/4 TR	PART	1
9	12919	FLANGE	PART	1
10	92232	SCRW, 6-32 X 1/8 SKT HD FTL PT SS	PART	1
11	12920	BONNET, TIP-END	PART	1
12	12070	HANDLE ADAPTER, SHORT	PART	2
13	12908	HANDLE LEVER - COLD	PART	2
14	92426	SCRW, M4 X 12 PHL FLT HD SS	PART	2
15	20-333	DECO NUT ASM	ASSEMBLY	2
16	12921	BONNET, WALL-END	PART	1

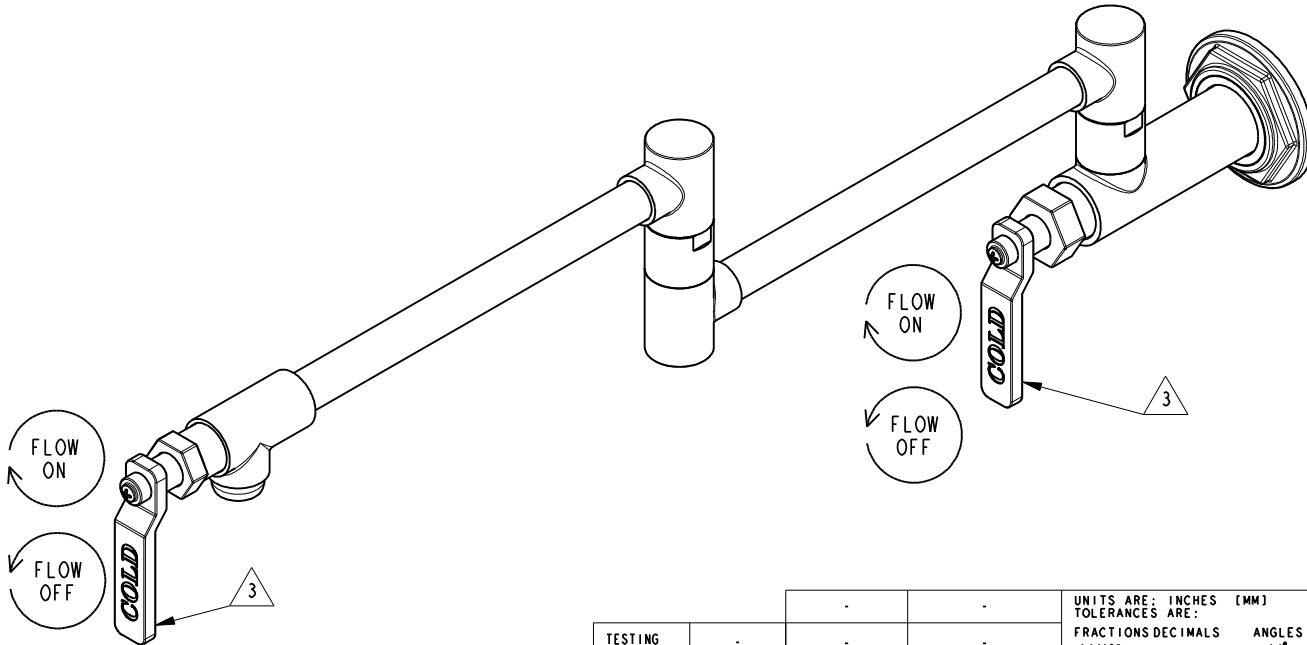

ZONE	REV	DESCRIPTION	DATE	APPROVED
-	C	EN-4300q	11/20/20	R.S.
-	B	EN-4062	01/06/20	J.M.
-	A	EN-3886	06/05/19	J.M.
-	-	EN-3443	09/17/18	J.M.

COPYRIGHT 2005 BRASSTECH, INC. THESE DRAWINGS AND THE DESIGNS DEPICTED HEREIN ARE THE PROPRIETARY PROPERTY OF BRASSTECH. ANY USE OR REPRODUCTION IS SUBJECT TO THE EXPRESS APPROVAL OF BRASSTECH. UNAUTHORIZED USE IS STRICTLY PROHIBITED. ALL RIGHTS RESERVED.

TESTING	-	-	-
ASSEMBLY	-	-	-
PLATING	-	-	-
POLISHING	-	NEXT ASSY	USED ON
MACHINING	-	APPLICATION	
TOOLING FIXTURE #	REMOVE ALL BURRS AND SHARP EDGES		

UNITS ARE: INCHES [MM]		
TOLERANCES ARE:		
FRACTIONS DECIMALS	ANGLES	
±1/16"	.X ±.1 [2,5]	±1°
	.XX ±.06 [1,5]	
(X.XXX) DENOTES CRITICAL DIMS. ALL THREADS ARE CRITICAL		
DRAWN	JINSON	11/20/20
CHECKED	R.S.	11/20/20
APPROVED	R.S.	11/20/20

BRASSTECH 2001 CARNEGIE AVE. SANTA ANA, CA 92705 (949) 417-5207
INCORPORATED

POT FILLER

DWG NO.	3220-5503	REV	C
SCALE	.300	REF.	-
SHEET	1	OF	3

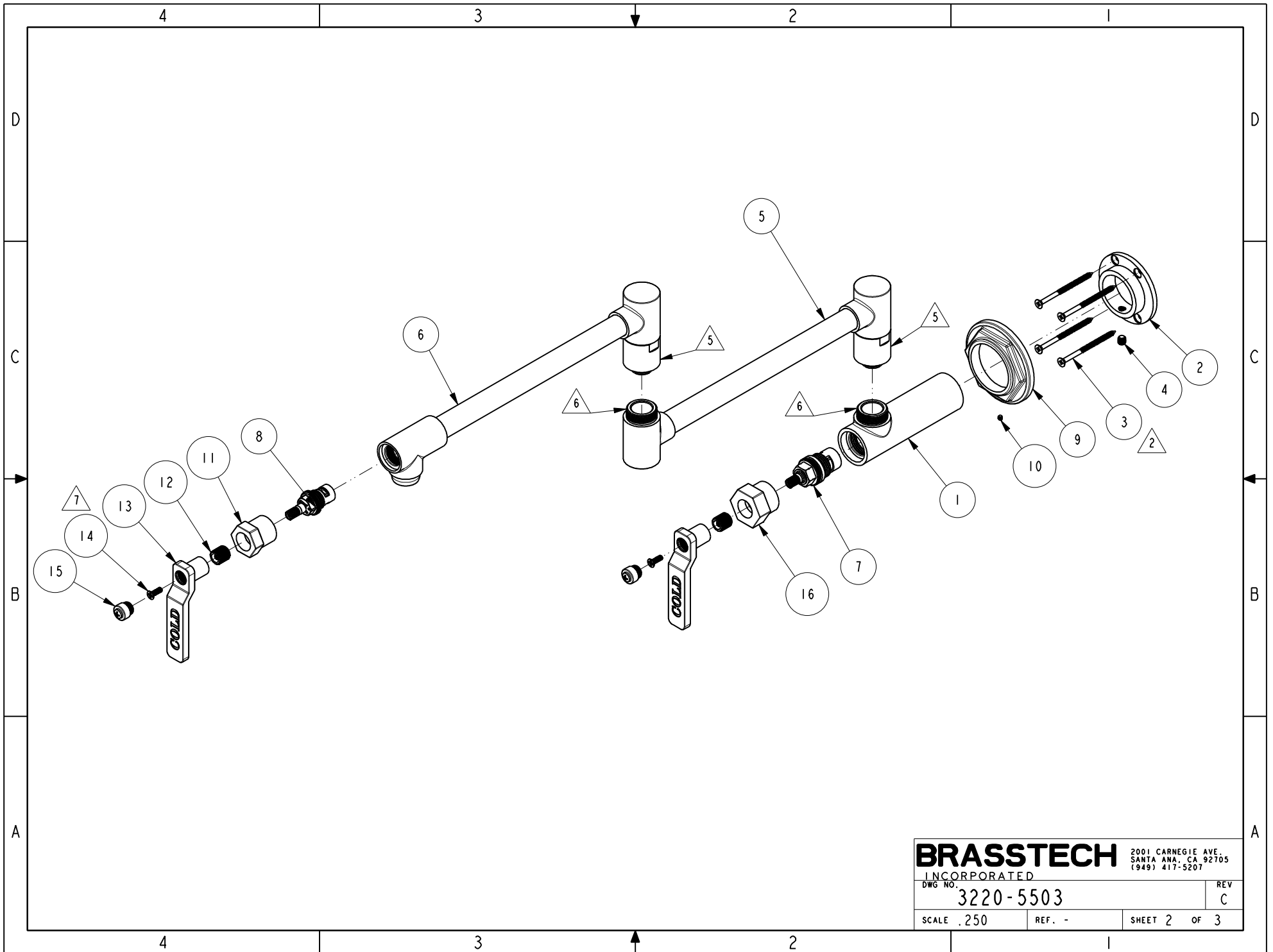

BRASSTECH 2001 CARNEGIE AVE.
 INCORPORATED SANTA ANA, CA 92705
 (949) 417-5207

DWG NO.	3220-5503	REV	C
SCALE	.250	REF.	-
SHEET 2		OF 3	

