

CAL KING FOOTBOARD STORAGE BED ASSEMBLY INSTRUCTIONS

BOX1
A. HEADBOARD 1 PC

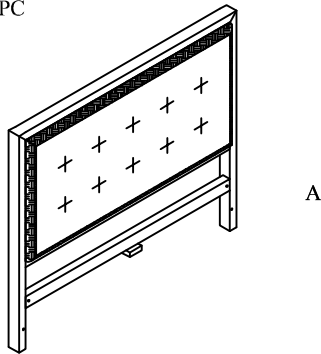

BOX2
B. FOOTBOARD 1 PC
D. SUPPORT SLAT 1 PC
E. SUPPORT LEG 2 PC
F. SLAT ROLL (13 SLATS) 1 PC

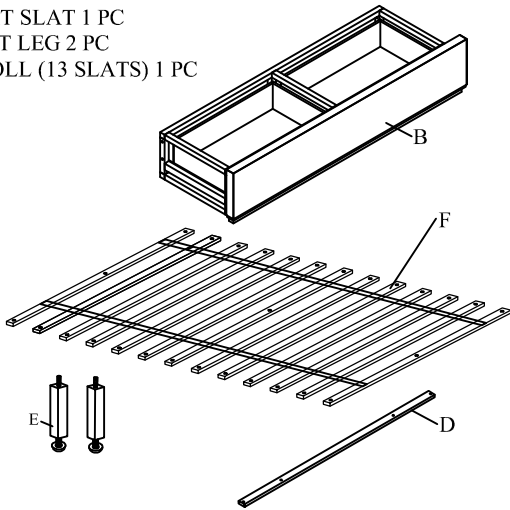

BOX3
C. SIDE RAIL 2 PCS

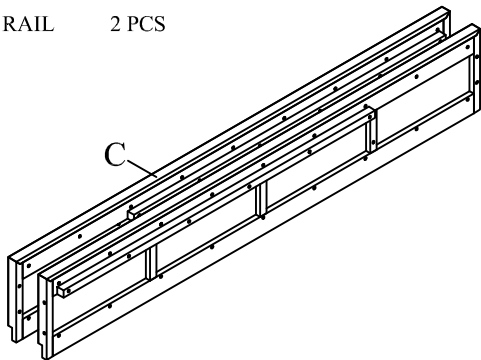

CAL KING FOOTBOARD STORAGE BED ASSEMBLED

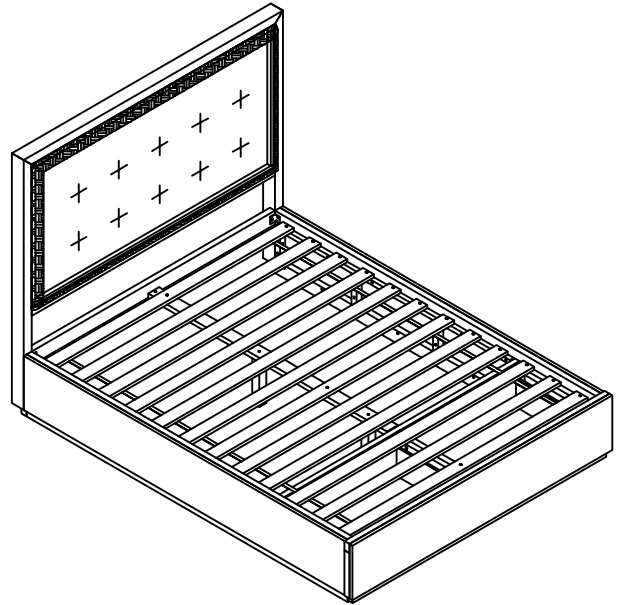

HARDWARE PACKED IN BOX3

1	ALLEN BOLT (M8X50)		2 PCS
2	ALLEN BOLT (M8X20)		2 PCS
3	SPRING WASHER (M8)		4 PCS
4	FLAT WASHER (M8)		4 PCS
5	ALLEN BOLT (M6X50)		8 PCS
6	SPRING WASHER (M6)		8 PCS
7	FLAT WASHER (M6)		8 PCS
8	WOOD SCREW(M4 X 30)		31 PCS
9	Allen Key		1 PC

TOOL REQUIRED

PHILLS HEAD SCREW
DRIVER (NOT PROVIDED)

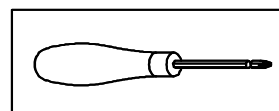

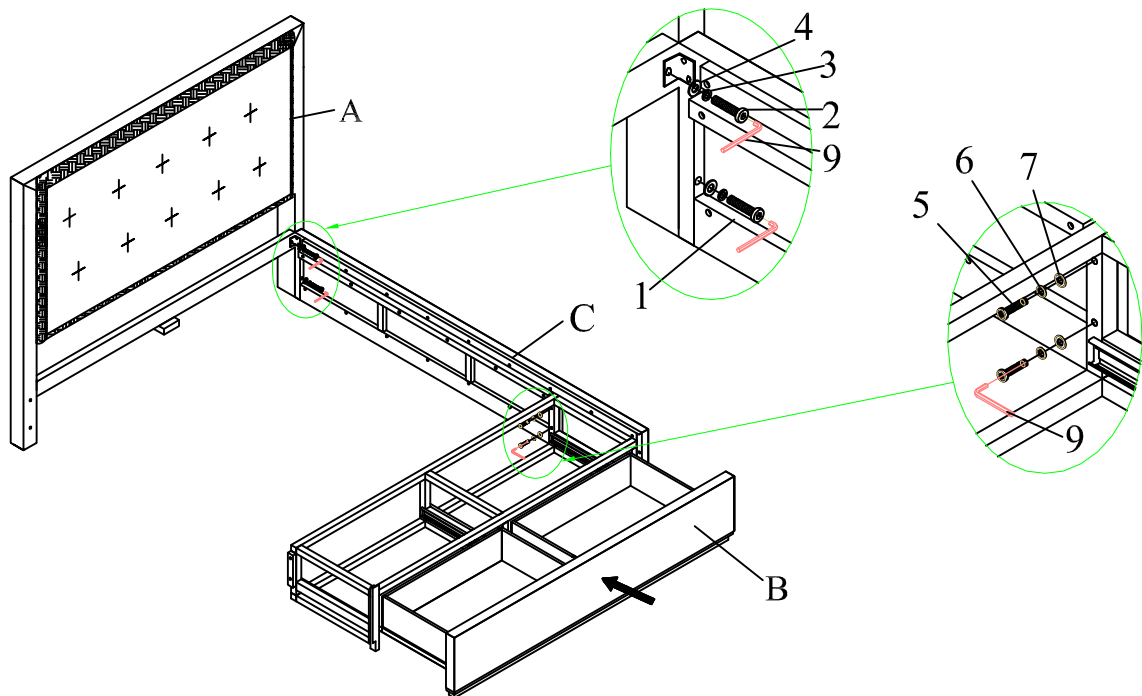

STEP 1: FOLLOWING THE ILLUSTRATION, ATTACH ONE SIDE RAIL (C) TO THE HEADBOARD (A) USING ONE M8X20 ALLEN BOLT (2), M8 SPRING WASHER (3) AND M8 FLAT WASHER (4) THROUGH THE METAL 'L' BRACKET. USE ONE M8X50 ALLEN BOLT (1), M8 SPRING AND M8 FLAT WASHER THROUGH THE WOODEN SIDE RAIL SUPPORT. DO NOT TIGHTEN THE BOLTS COMPLETELY.

PULLING OUT THE FOOTBOARD STORAGE DRAWER (B), ATTACH THE FOOTBOARD FRAME TO THE SIDE RAIL USING FOUR M6X50 ALLEN BOLTS (5), M6 SPRING WASHERS (6) AND M6 FLAT WASHERS (7). DO NOT TIGHTEN THE BOLTS COMPLETELY.

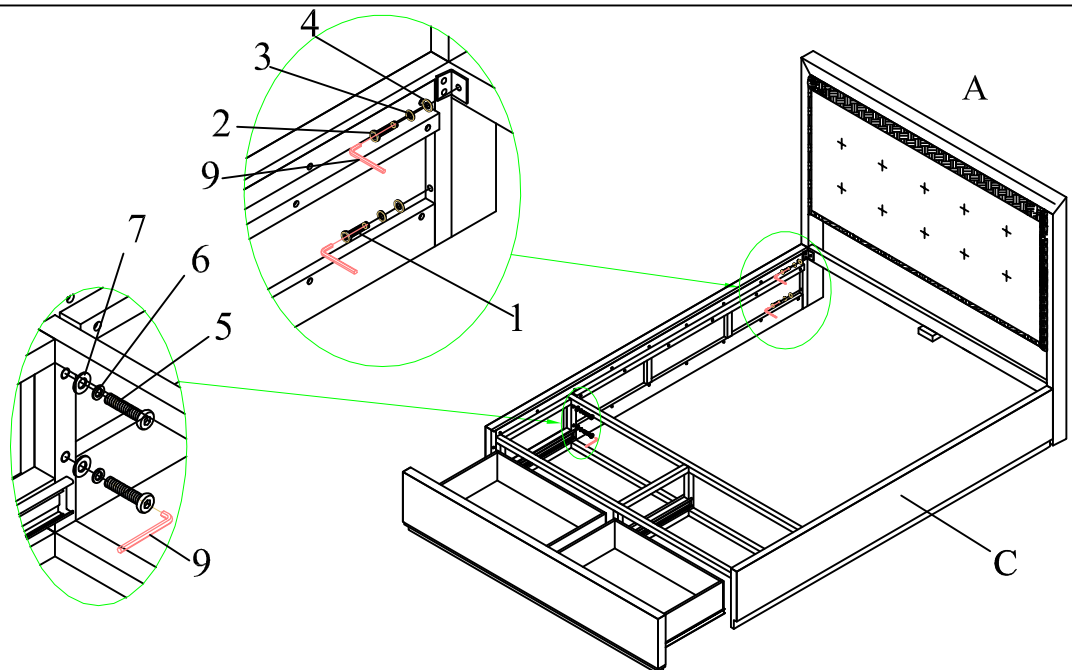

STEP 2: REPEAT STEP ONE FOR THE SECOND SIDE RAIL. TIGHTEN ALL ALLEN BOLTS FROM STEP 1 AND 2 COMPLETELY WITH THE ALLEN KEY (9).

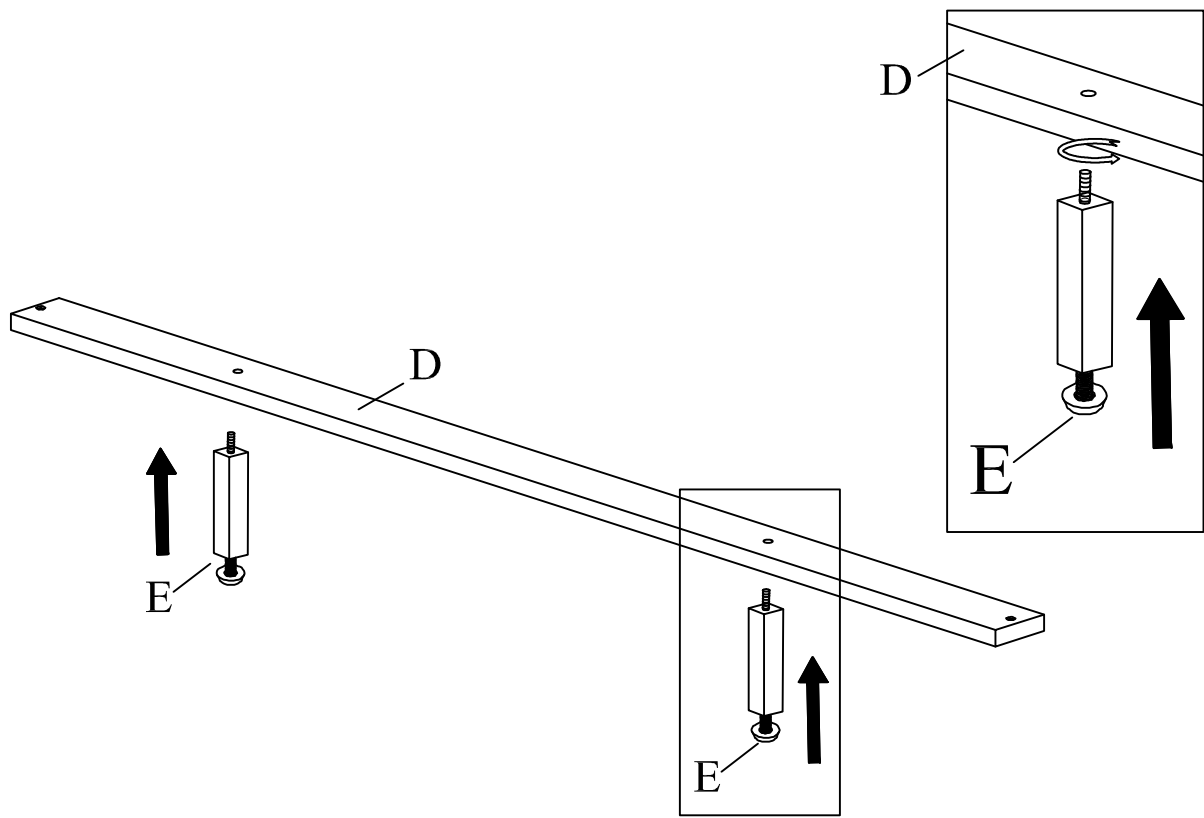

STEP 3: ATTACH THE SUPPORT LEGS (E) TO THE SUPPORT SLAT (D).

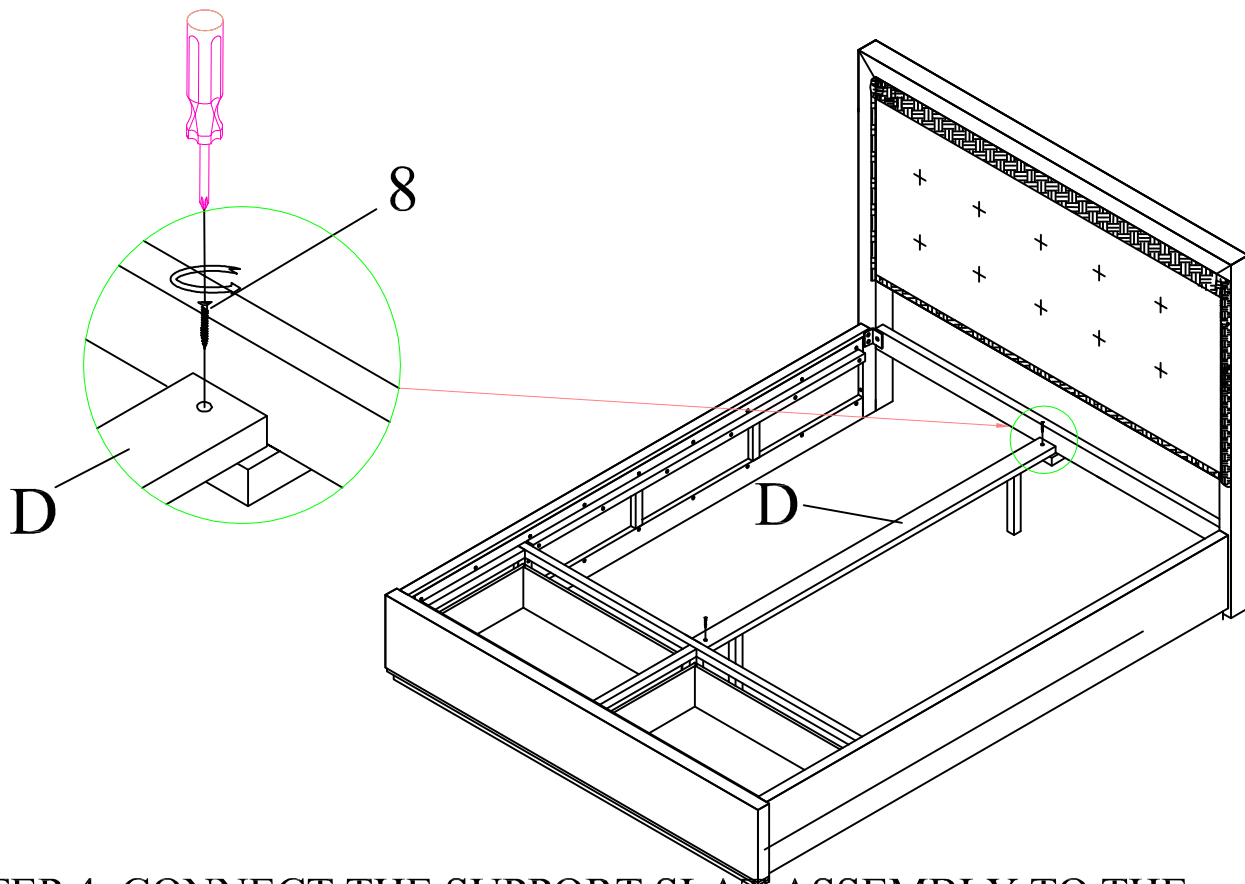

STEP 4: CONNECT THE SUPPORT SLAT ASSEMBLY TO THE HEADBOARD AND FOOTBOARD SUPPORT SLAT CLEAT USING TWO WOOD SCREWS (8).

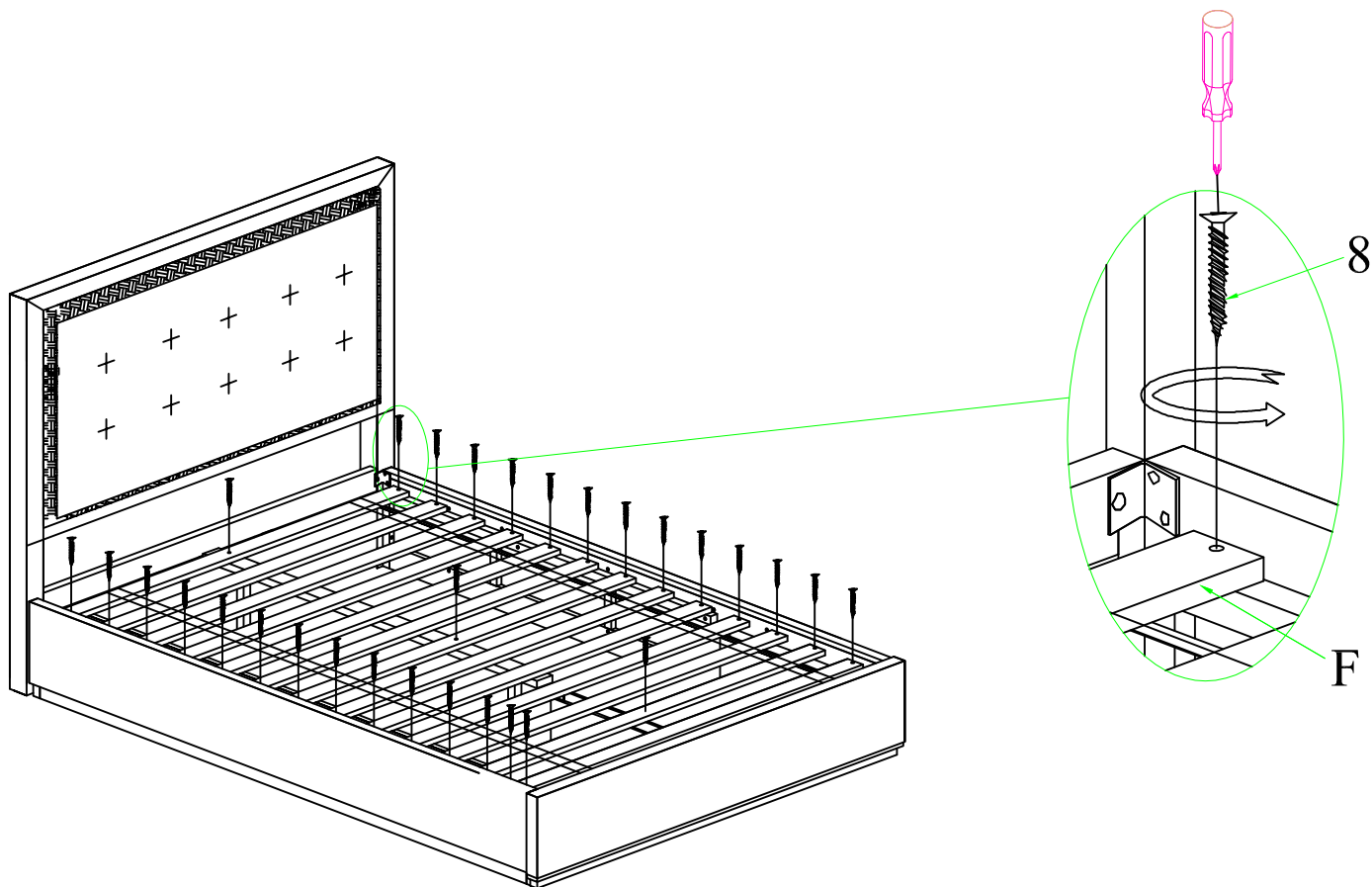

STEP 5: FOLLOWING THE ILLUSTRATION, PLACE AND CONNECT THE SLAT ROLL (F) TO THE BED WITH THE PROVIDED WOOD SCREWS.

INSTRUCTIONS FOR ADJUSTING LEVELER

POSITION THE BED IN YOUR SPACE AND LOCATE THE LEVELER UNDER EACH SUPPORT LEG. TURN THE LEVELER COUNTER-CLOCKWISE TO EXTEND THE LEVELER AND CLOCKWISE TO RETRACT IT.

ADJUST EACH LEVELER UNTIL EACH SUPPORT LEG IS APPLY EQUAL, UPWARD PRESSURE ON THE SUPPORT SLAT.

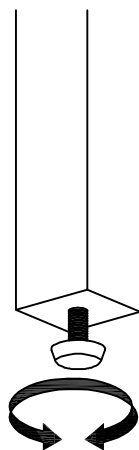

MAINTENANCE INSTRUCTIONS:

REMOVE YOUR MATTRESS, AND BOX SPRING IF APPLICABLE, BEFORE MOVING YOUR BED.

LIFT YOUR BED WHEN MOVING IT; DRAGGING CAN DAMAGE THE SUPPORTS.

RE-ADJUST THE LEVELERS AFTER MOVING YOUR BED.