

Loveseat Recliner

Operating instruction

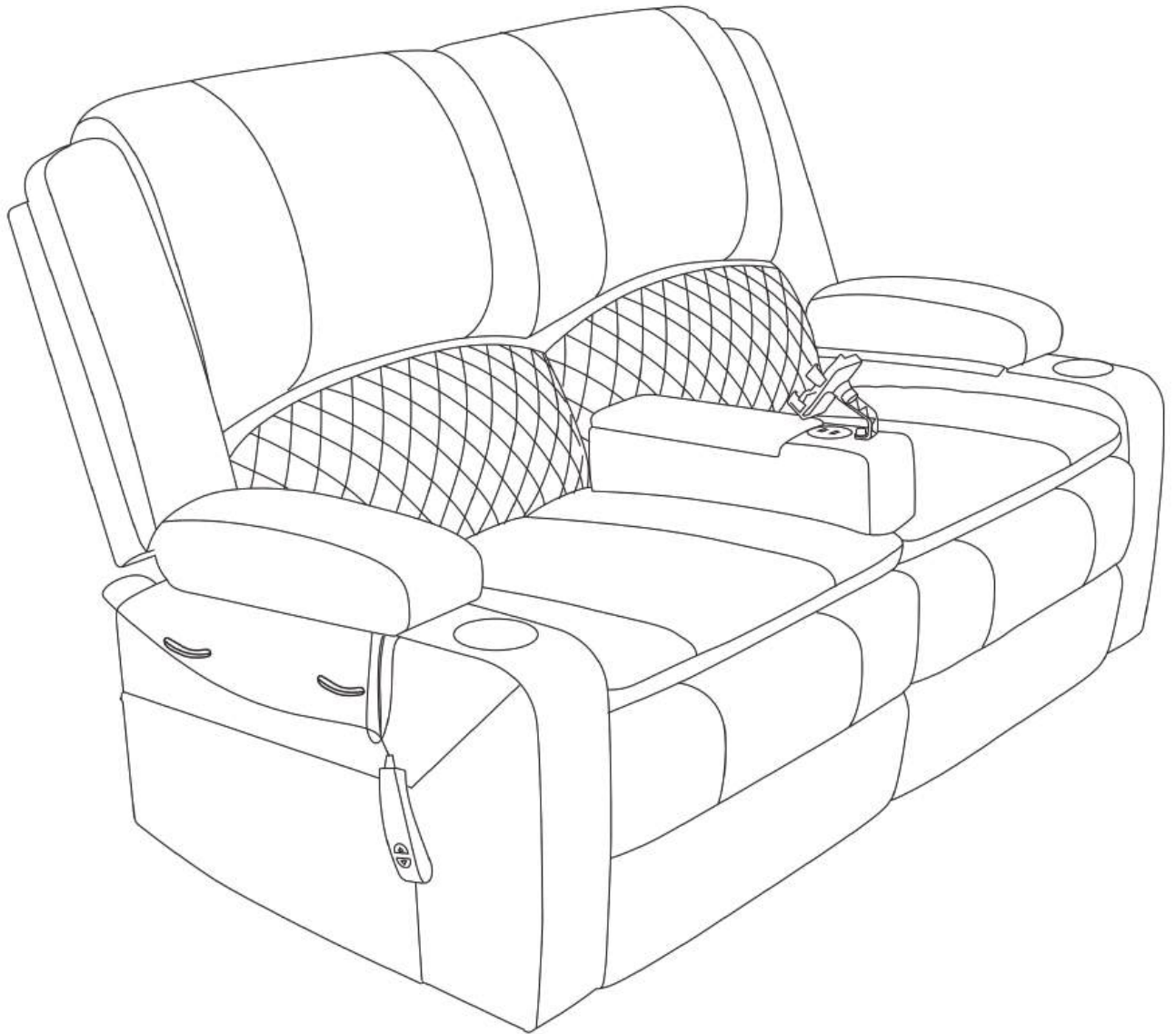

NOTE : This sofa is shipped in 3 box. All accessories included. If you have any questions after receiving the recliner. Please contact us in time and provide pictures. We will try our best to help you solve it.

Customer Service Email: phjidhpiKK@outlook.com

WARRANTY

So glad you have completed the assembly and can enjoy it. If you are satisfied with our products, thank you for showing your favored recliner to your around.

The quality of our furnitures has been strictly controlled. Each stage of the product upgrading has condensed the efforts of employees in various departments. We strive to minimize the probability of failure of new products and insist on providing customers with worthless after-sales service.

AFTER-SALE POLICY

For return reason:

Wrong purchase, bought by mistake, no longer needed, doesn't meet expectation, a size smaller than expectation, customer need to cover the return shipping fee.

For cancel order:

Customer needs to pay for shipping fee and carrier handle fee if the item has been shipped out.

For change address:

Customer needs to pay for extra shipping fee and carrier handle fee if the item has been shipped out.

Customer Service: Any problem with the product or shipping issue, please feel free to contact us, we will try our best to serve and help.

ATTENTION

Enjoyable time on recliner is coming after 15 minutes of installation!

- 1. Please check the manual carefully and make sure you have received all the parts.**
 - 2. If there is any missing parts, please let us know the letter of the parts you need.**
 - 3. If there is any damage parts, please send clear photos to us, we will check and offer you best solution soon.**
-

How to Contact the Seller (After Placing an Order)

Important: Please do not click “Return or Refund” when contacting us. Simply send us a message directly, and we will resolve your issue quickly and properly.

On Desktop

1. Log into your Amazon account
2. Go to Returns & Orders in the top right
3. Find your order
4. Click Problem with order
5. Select your issue
6. Click Contact seller
7. Type your message and send

On Amazon Shopping App

1. Open the Amazon app
2. Tap You at the bottom
3. Go to Your Orders
4. Find your order
5. Tap Problem with order or Get help
6. Select your issue, then tap Contact seller
7. Send us your message





















How to Check Messages





1. Desktop: Go to Account & Lists → Your Messages → Buyer-Seller Messages
2. App: Go to You → Your Messages

We will reply to you within 24 hours

PARTS LISTING

BOX - A			
Part		Qty	
A1		1PC	Chair Seat Cushion (Left)
B1		1PC	Armrest (Left)
I1		1PC	Left Backrest Wings
M1		1PC	Left Armrest Padding
BOX - B			
A2		1PC	Chair Seat Cushion (Right)
B2		1PC	Armrest (Right)
I2		1PC	Right Backrest Wings
M2		1PC	Right Armrest Padding
3		8PC	Screw
4		4PC	Plastic Pad
5		8PC	Nut
6		2PC	Connector
7		1PC	Allen Key
8		1PC	Power Cable
9		1PC	Power Box
10		1PC	Power Cord
J		1PC	Armrest Power Cord
K		2PC	Remote Control
L		2PC	Plastic cup holder

PARTS LISTING

BOX - C			
C		1PC	Removable Armrest
D		1PC	Phone Mount
E		1PC	Phone Mount Fixing Screw
D1		1PC	Left Backrest
D2		1PC	Right Backrest

Step 1. Connect the Left and Right Seat Cushions (A1 & A2)

Friendly reminder: Before installation, lay a clean, soft carpet on the floor. Position the sofa footrest flat on the ground, then the metal frame to align with the mounting holes.

Gather Parts: Part 3 *8, Part 4 *4, Part 5 *8, Part 6 *2, Part 7 *1

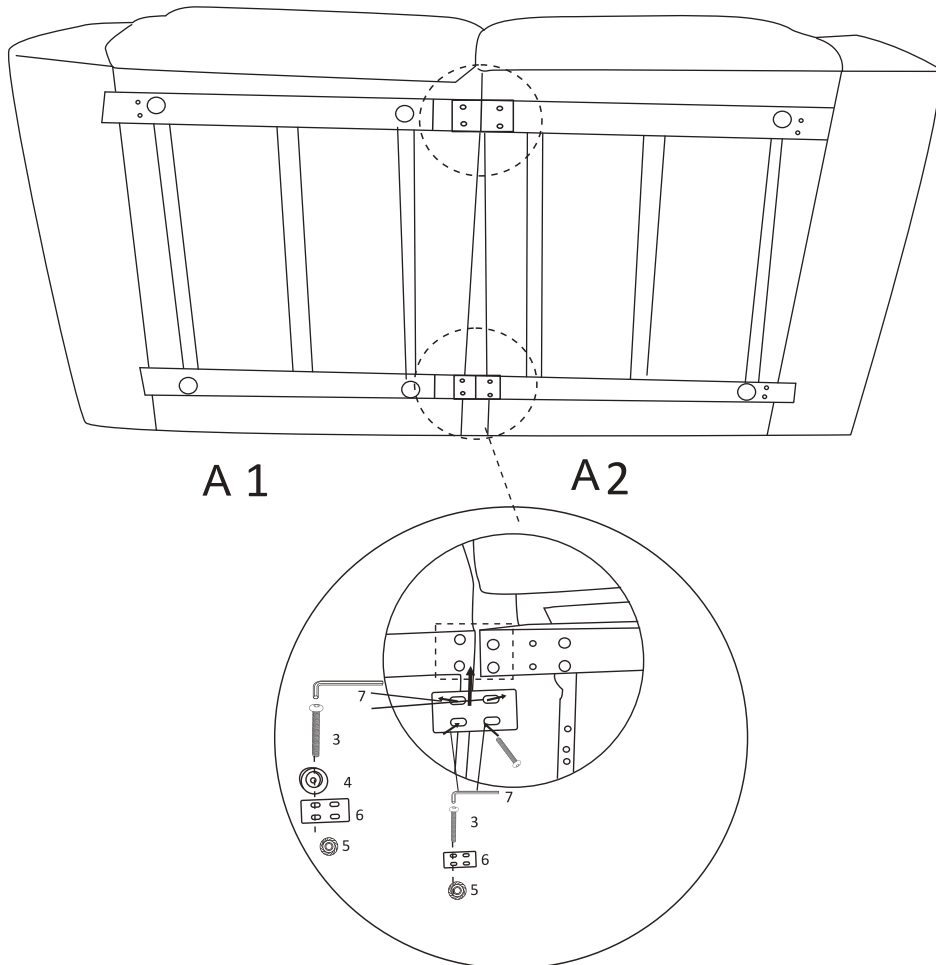

Procedure:

1. Use Part 6 to connect seat cushions A1 and A2.
2. To allow for alignment adjustment, do not fully tighten the screws at this stage. Tighten the screws only to approximately 80-90% of their full tightness.
3. Final tightening will be performed after the installation is complete and all parts are properly aligned.

Step 2. Assemble the Base and Armrests

Gather Parts: Take out the chair seat cushions (A1, A2) and the left and right armrests (B1, B2).

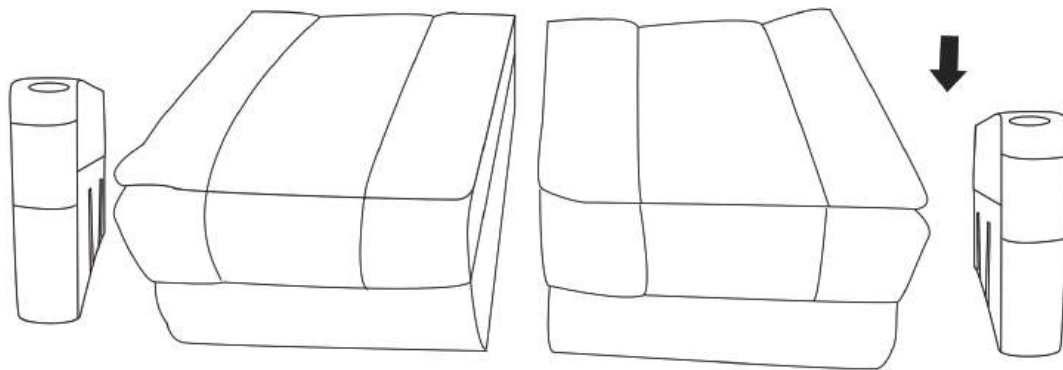

1. Position Base:

Place the left seat cushion (A1) on a stable, level floor.

2. Attach Left Armrest:

At an upward angle, insert the connector of the left armrest (B1) down into the two connectors on the left seat cushion (A1). Push down until it clicks into place and is secure.

3. Attach Right Armrest:

Follow the same steps to attach the right armrest (B2) to the right seat cushion (A2).

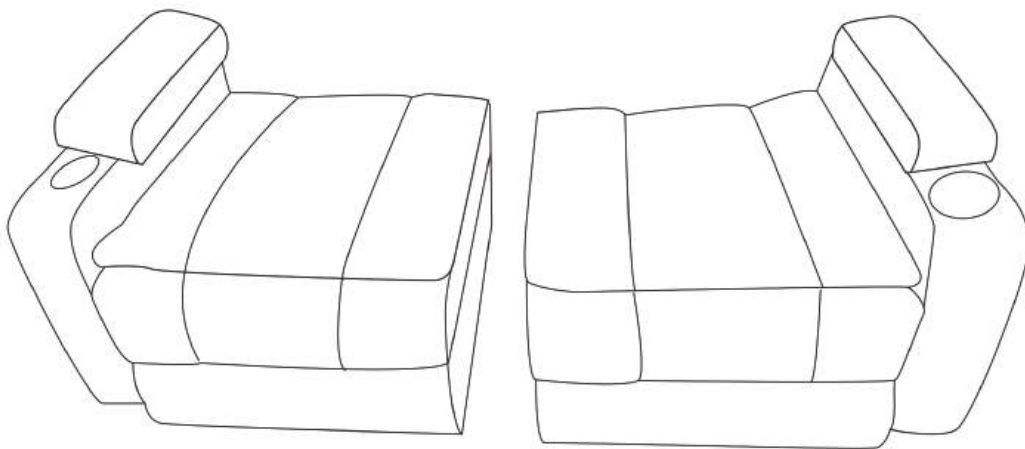

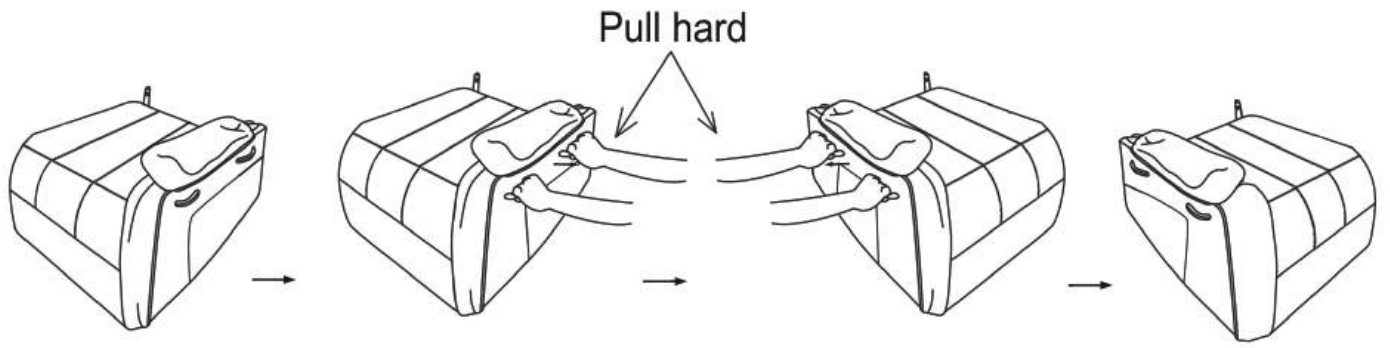

Locate the small tabs on the armrest panels. Grip the tabs and pull outward until you hear a click. The armrests are now fully extended and installed. To fold the armrests back down later, pull the tab handles outward in the same manner.

Left

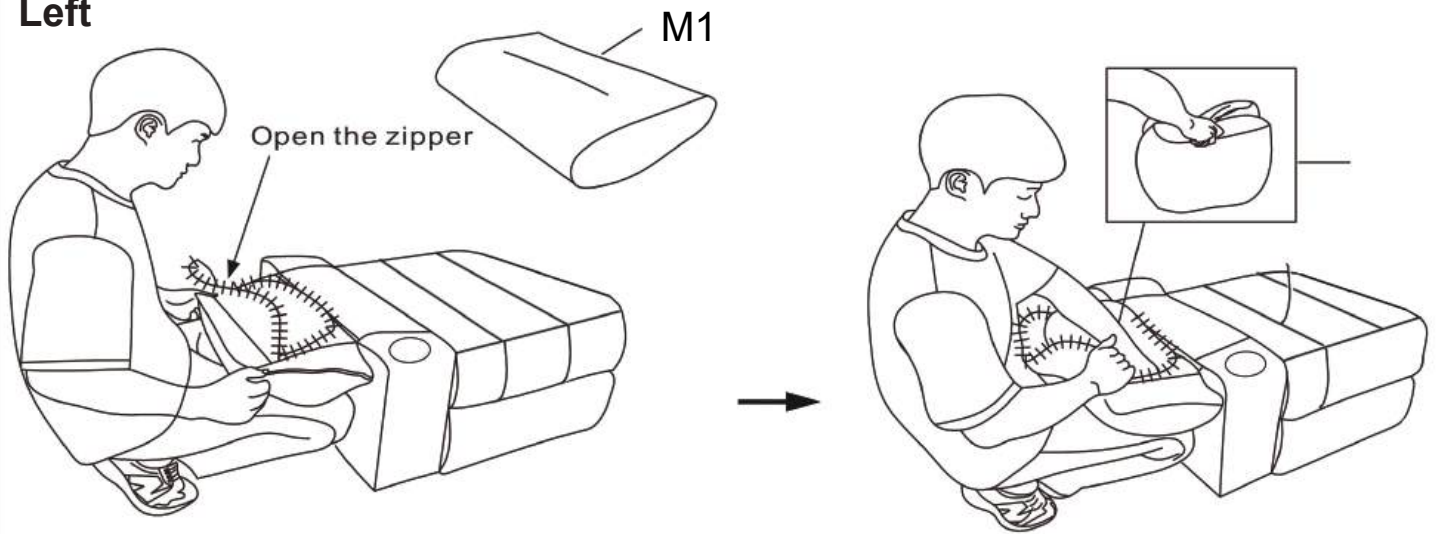

Insert the Left Armrest Padding into the corresponding armrest cover.

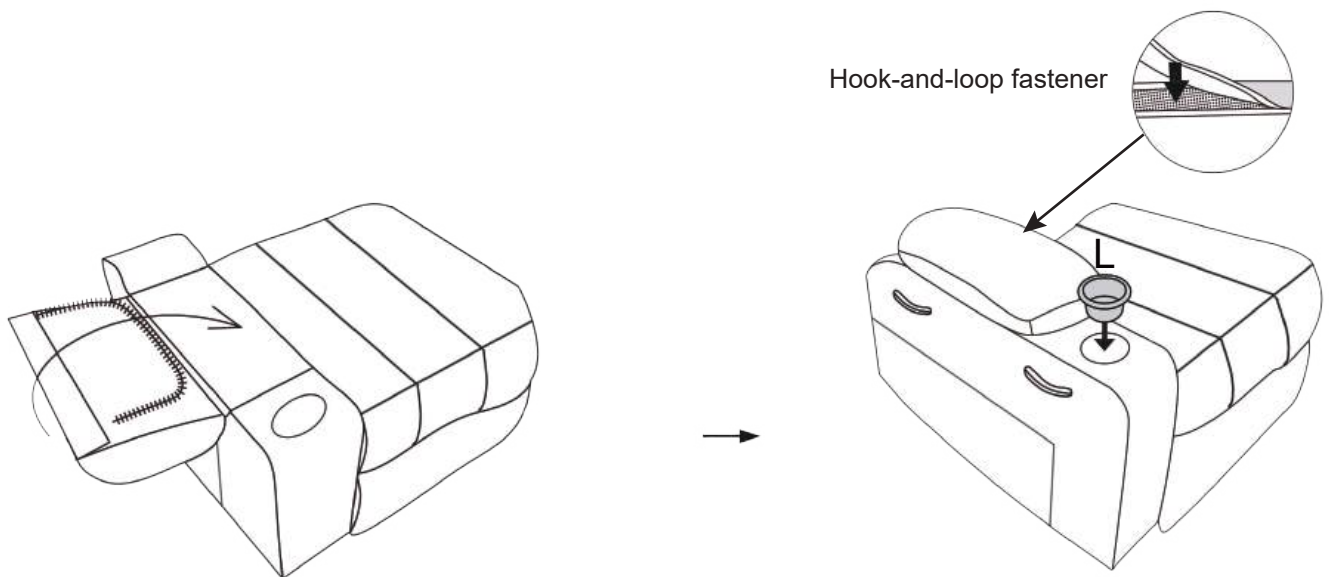

Right



M2

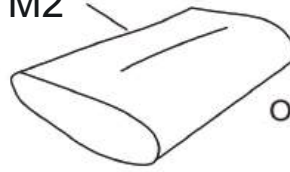

Open the zipper

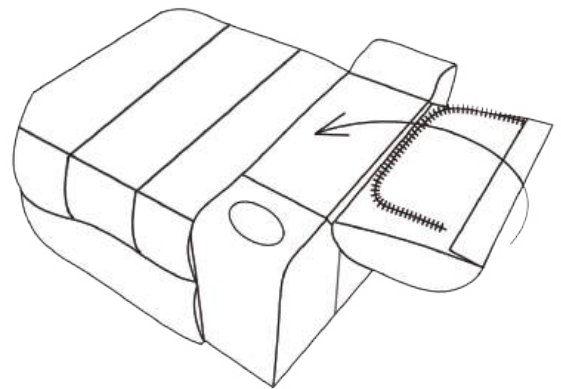
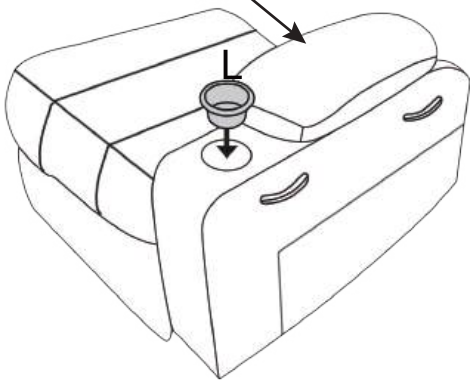
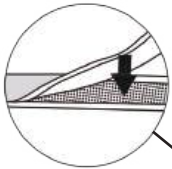
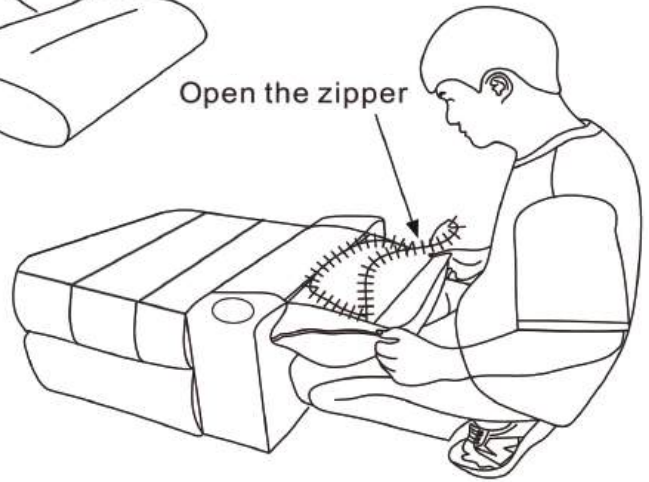

Step 3. Assemble the Backrests to the Seat Cushions

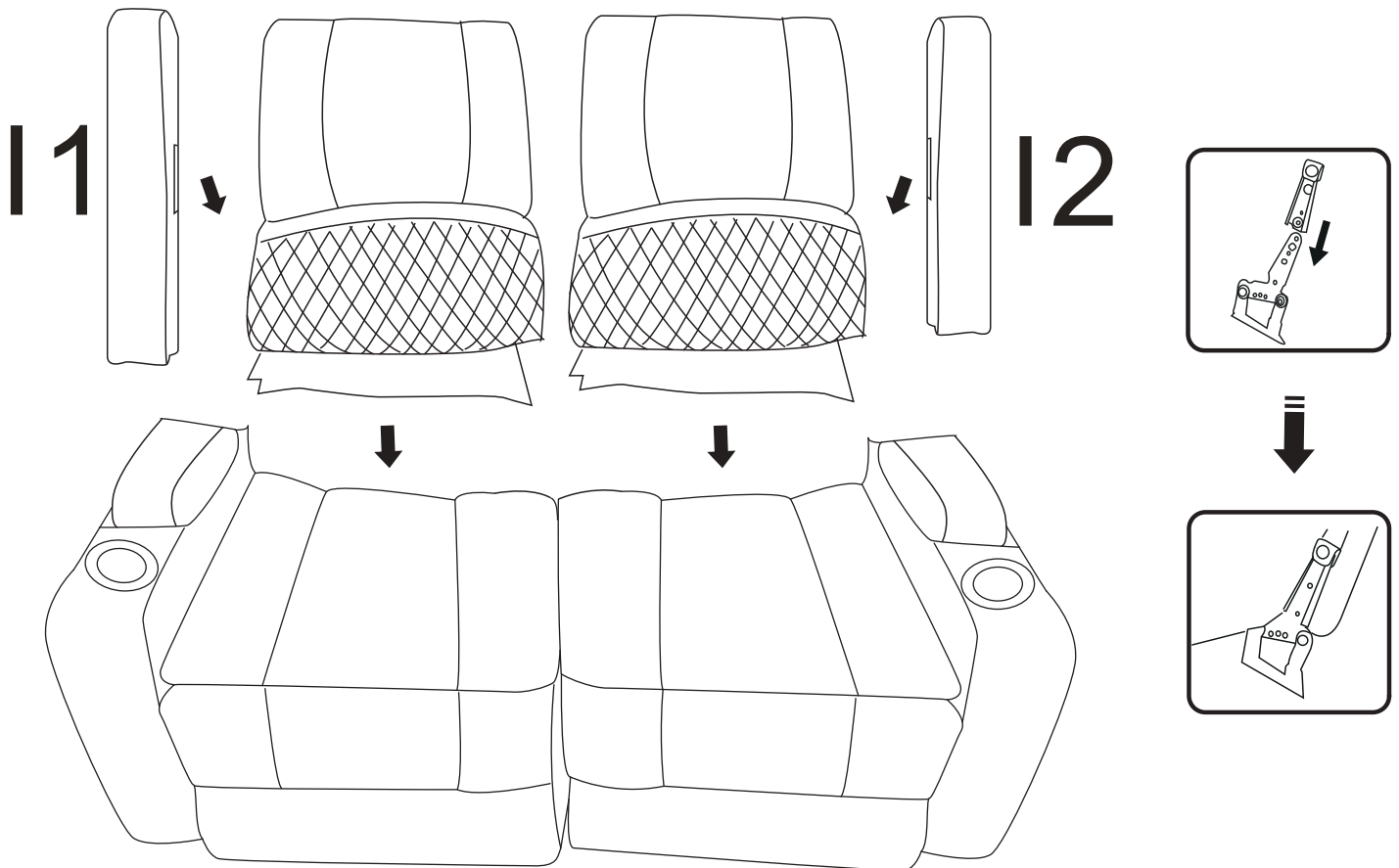

Attach Left Backrest:

① Insert the metal pins of the left backrest (D1) into the slots on the left seat cushion (A1).

Attach Right Backrest:

Follow the same procedure to install the right backrest (D2) onto the right seat cushion (A2).

② Attach the 2 backrest wings (I1 and I2 as picture) to the backrest B with the same way.

Step 4. Detachable Armrest Power

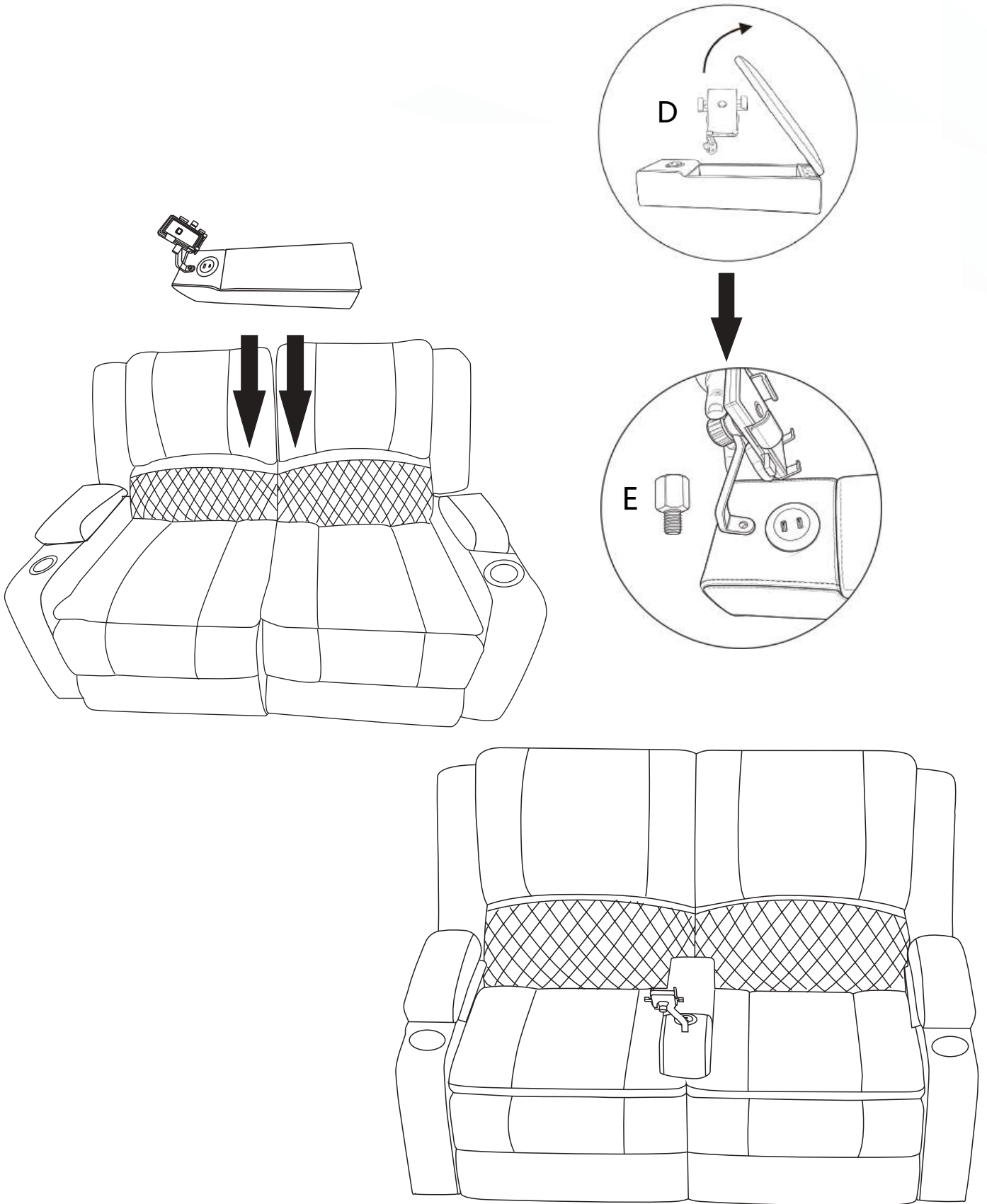

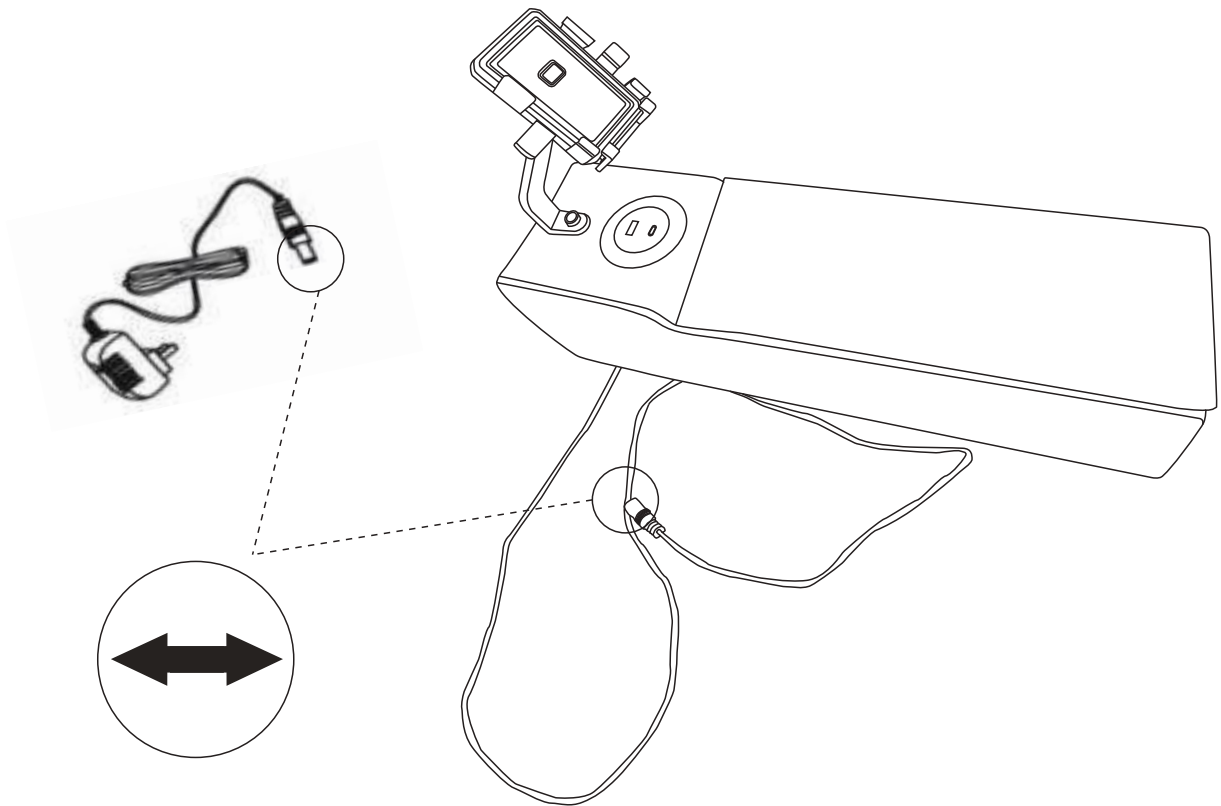
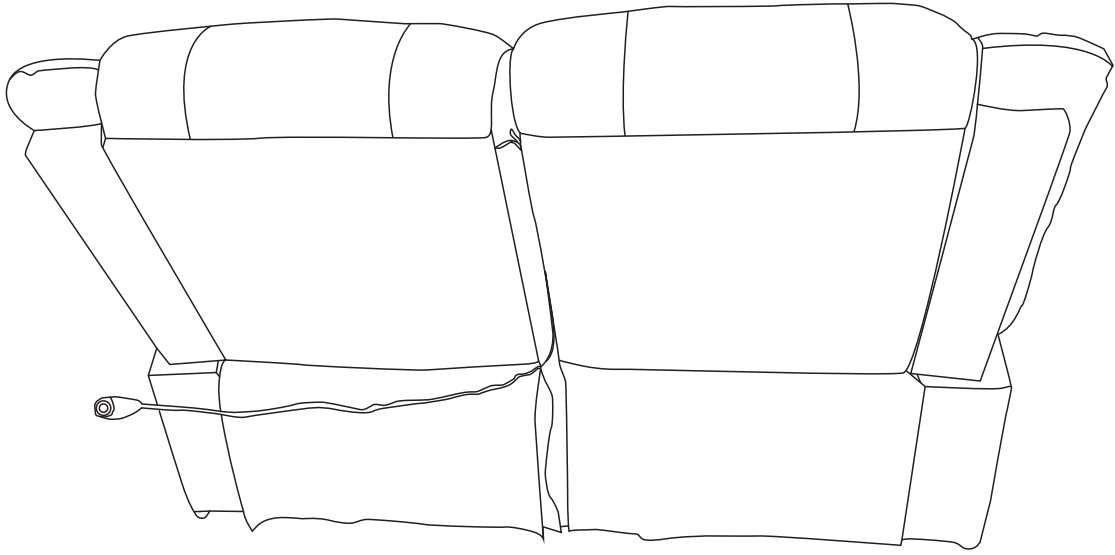

Step 5. Electrical Connection

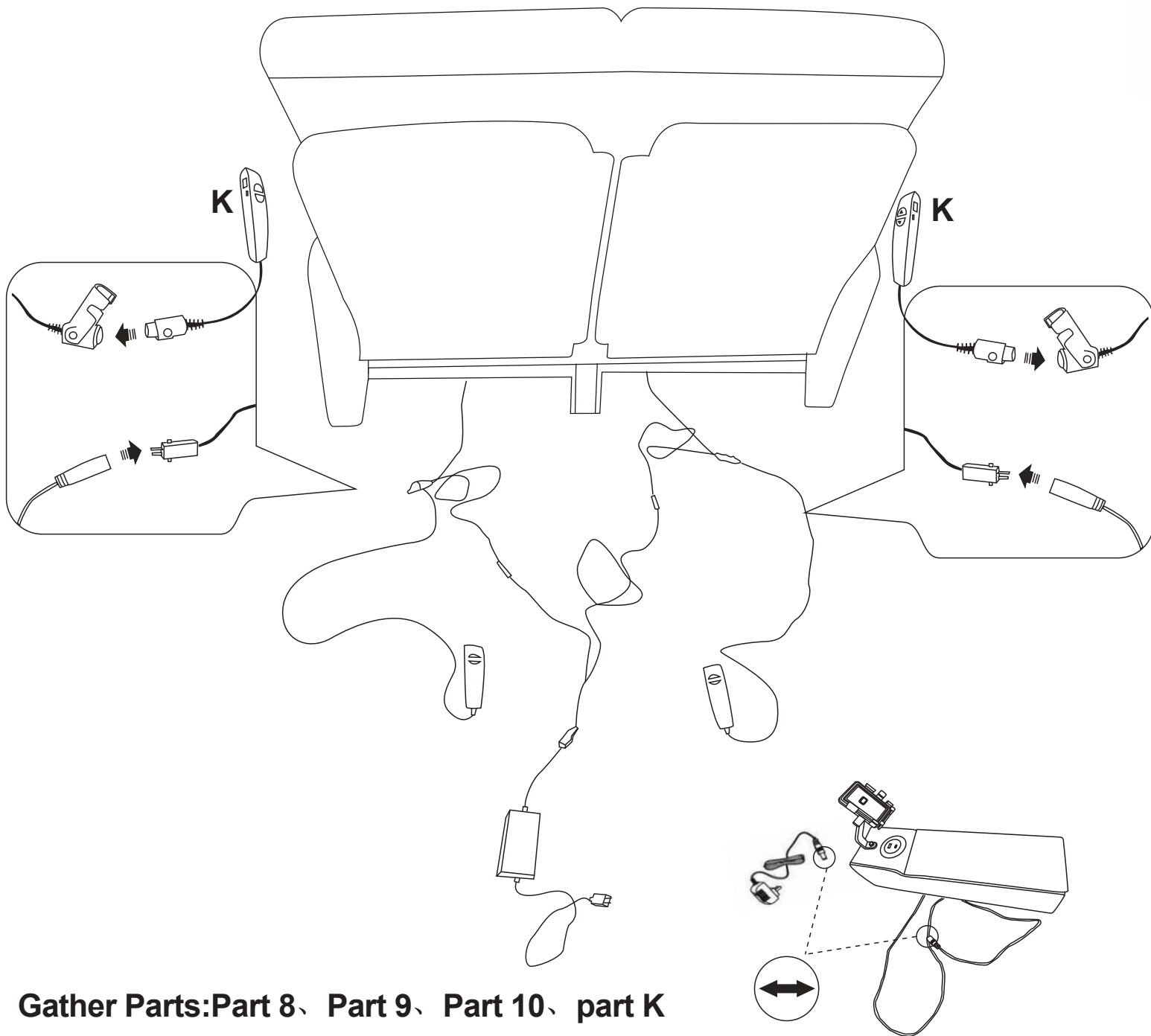

Gather Parts: Part 8, Part 9, Part 10, part K

Assembly Steps:

- 1. Locate the power cord coming from the backrest and plug it into Part 8.**
- 2. Connect the power cord from the base to Part 9, then plug Part 9 into Part 10.**
- 3. Once all connections are securely in place, turn on the power switch and the unit is ready for use.**

Step 6. Enjoy the comfortable

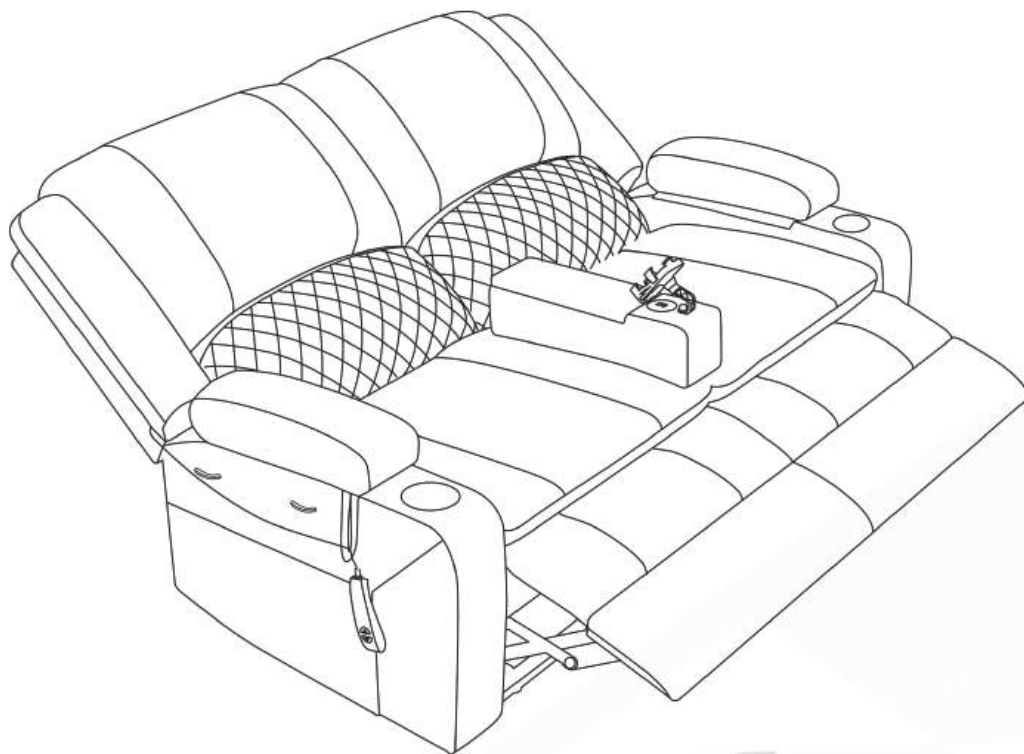
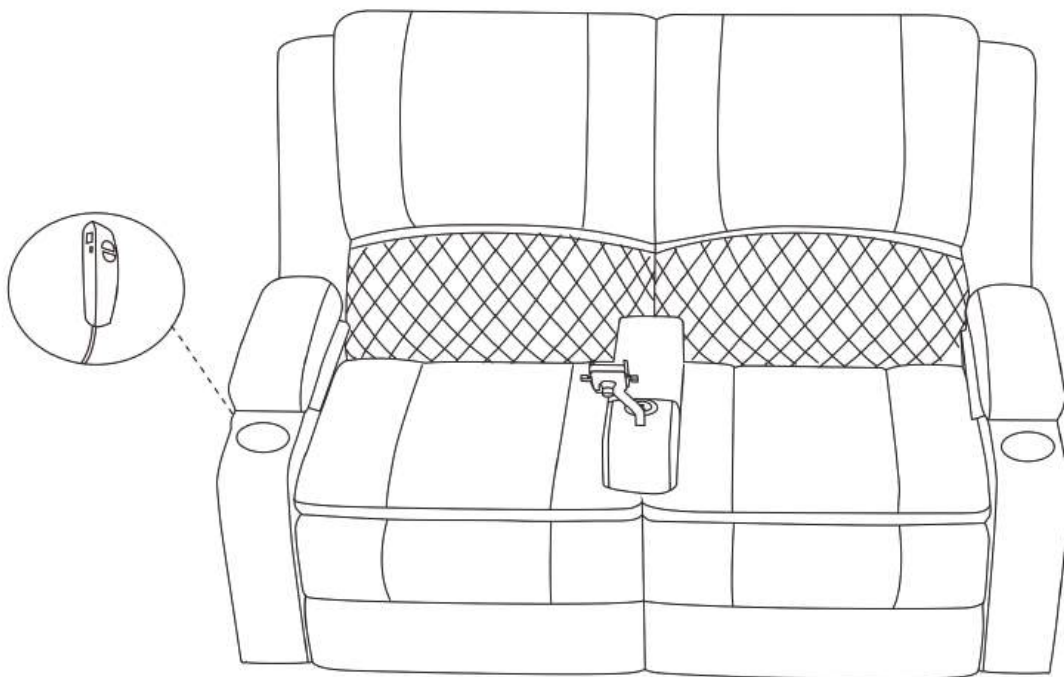

WARRANTY

1. The quality of our products is strictly managed. Every stage of our product development embodies the dedication of our team across all departments. We strive to minimize the failure rate of new products and are committed to providing customers with a worry-free after-sales service experience.
2. If you encounter any damage or quality issues upon receiving your order, please contact us promptly. Our professional after-sales team will respond to you as soon as possible and help resolve the issue.
3. To help us assist you quickly, please describe the problem in detail. If possible, please also upload pictures of the product for our reference and provide us with the relevant part number (as shown in the instructions).

AFTER-SALES POLICY

1. Warranty Service:

Within the product warranty period, we provide replacement parts for any manufacturing defects or quality issues.

For functional issues, we may request your cooperation in performing basic troubleshooting steps provided by our support team. Sharing the results with us is necessary to diagnose the problem and determine the most suitable solution.

2. Returns & Refunds:

We do not accept refunds for non-faulty products or reasons unrelated to product quality.

If you are dissatisfied after receiving the product, please contact us within 3 days.

All returned items must be in their original condition to be eligible for a refund. Upon inspection and approval, a refund will be issued to your original payment method.