

ASSEMBLY INSTRUCTIONS

60" Single Sink

- Please Unpack all parts and check against parts list on this instruction sheet before discarding the packaging .
- Note: We recommended at least 2 people assist in installation to avoid injury or damage to the product.

#	Part Description	Dimension		QTY
1	Floating vanity	1524X585X610		1 (pc)
2	Wooden Hanger	220x50x20		5 (pcs)
3	Plywood panel	1472x160x18		1 (pc)

hardware			
#	Drawing	Description	QTY
A		Long screws (Ø8x50mm)	21 (pcs)
B		Short screws (Ø8x35mm)	20 (pcs)

Tools

Screwdriver , drill , hammer (not included)

Assembly Instructions

Step 1:

- Hold the plywood panel (3) against the wall and align the screw holes with your stud locations.
- Use a writing untencil to mark the locations.
- See Figure 1 for recommended mounting height

- Use long screws (A) and drive them through the plywood panel to secure.

Step 2:

- Use short Screws (B) to attach the wooden hanger (2) to the plywood panel (3).
- use Figure 2 as reference for mounting height.

Step 3:

- Hang the vanity (1) on the wooden hanger (2).
- Use Figure 3 as reference for recommended final mounted height.

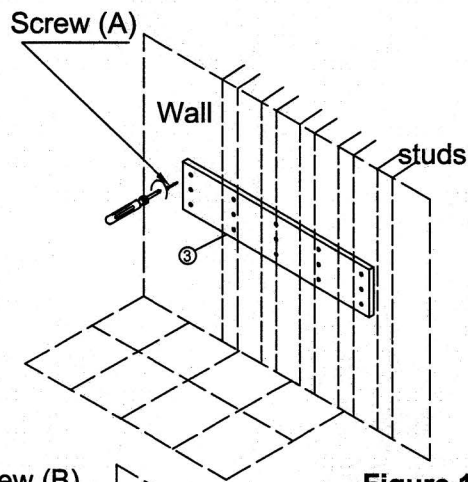

Figure 1

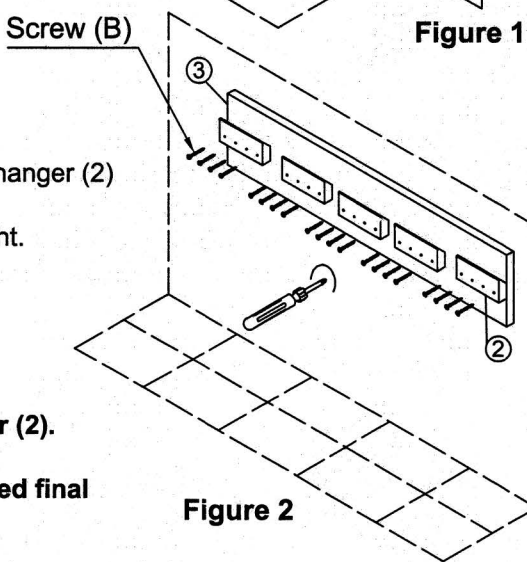
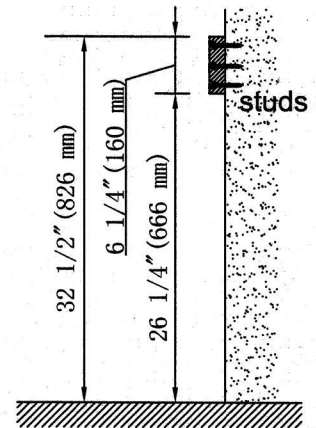
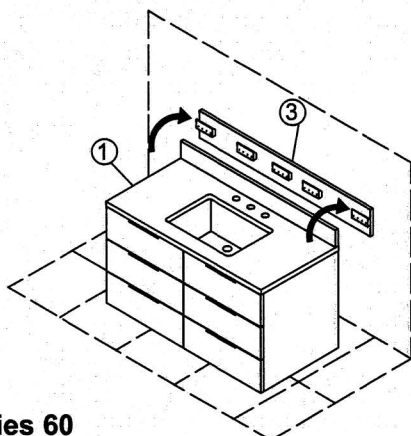
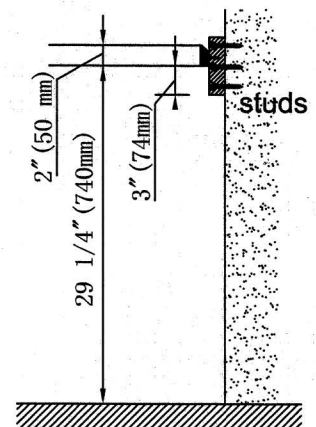
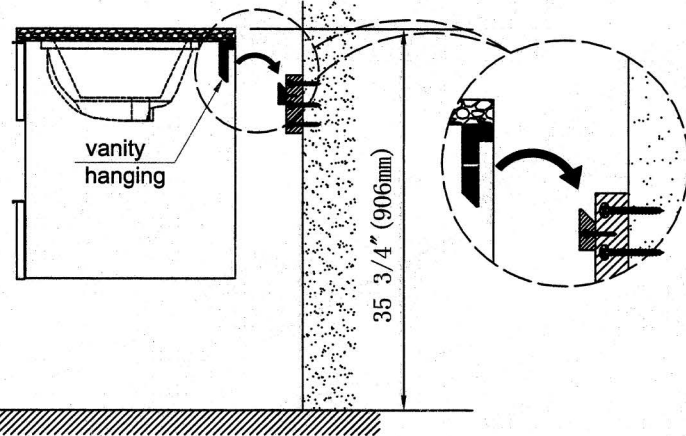

Figure 2



Vanities 60



ASSEMBLY INSTRUCTIONS

60" Single Sink

Step 4:

- Remove the middle drawers by pulling on the drawer, and pushing the locking device at the same time . See Figure 4.

Figure 4

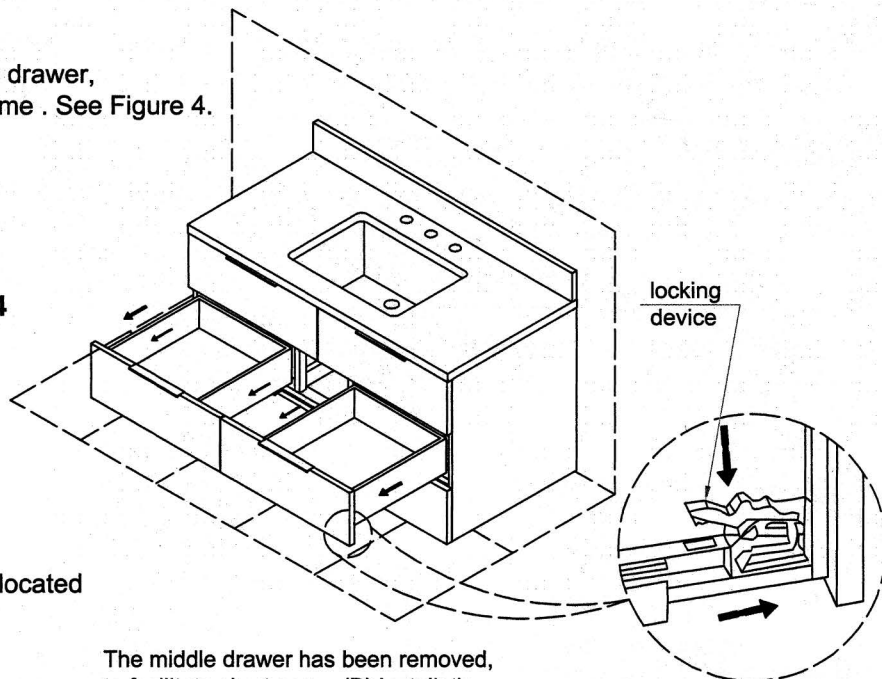

Step 5:

- Drive short screws (B) through the two holes located on the vanity hanging rail . See Figure 5.

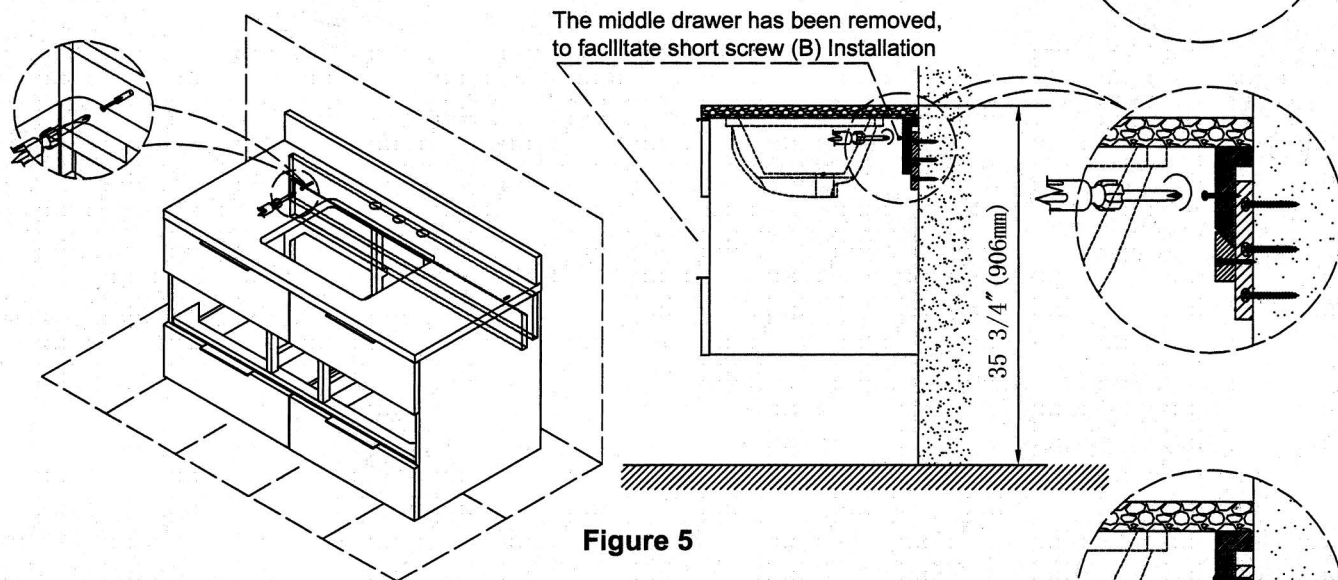

Figure 5

Step 6:

- Fully extend the slide rail out . See Figure 6.
- Place the drawer onto the slide rails. See Figure 7.
- To secure the drawer , close until a series of clicks are heard. See Figure 8.

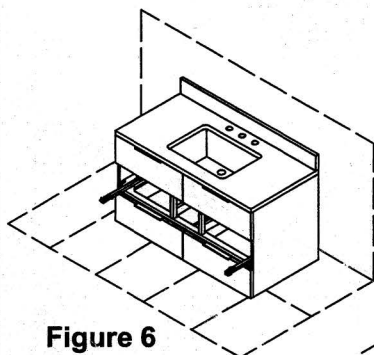

Figure 6

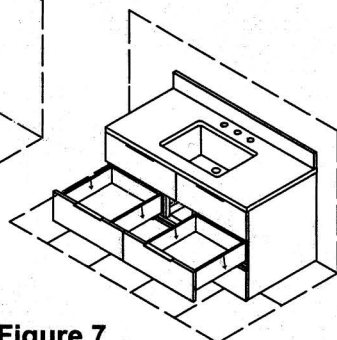

Figure 7

Figure 8

