

## NOTICE

- \* Please make sure that you have all parts indicated and they are in good condition before you begin assembly of this item. Refer to part list and hardware list below for guidance.
- \* This item should be assembled on a soft surface to prevent scratching the finish during assembly.
- \* This item may require periodic tightening.
- \* If you are having difficulty, our friendly Customer Care team is always here to help.















## PREPARATION

- \* Before beginning assembly of product, make sure all parts are present. Compare parts with part contents list and hardware contents list.
- \* If any part is missing or damaged, do not attempt to assemble the product.
- \* Estimated Assembly Time: 60 minutes.
- \* Tools Required for Assembly : Allen Key (included), Phillips screwdriver (not included)

## CARE AND MAINTENANCE

Adhesive felt pads should always be applied to areas of furniture which make direct contact with flooring, said application will prevent damage to the furniture and or surfaces on which the furniture lies. Objects placed on articles of furniture should rest on non abrasive material as to prevent damage to the wood finish. Wipe up spills immediately and avoid common hazards such as hot dishes, harsh solvents and abrasives. Cleaning should be done with a soft lint free cotton cloth dampened with water or furniture polish.

## Part List and Hardware List





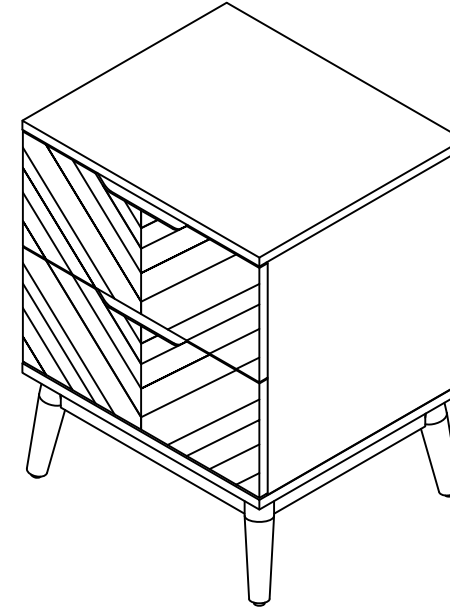

PIECE	DESCRIPTION	PICTURE	QUANTITY
A	TOP PANEL		1X
B	LEFT PANEL		1X
C	RIGHT PANEL		1X
D	BASE ASSEMBLY		1X
E	BACK PANEL		1X
F	LEG		4X
G	DRAWER FRONT		2X
H	DRAWER LEFT		2X
I	DRAWER RIGHT		2X
J	DRAWER BACK		2X
K	DRAWER BASE		2X
HW1	BOLT 6 x 1 x 25 MM		8X
HW2	FLAT HEAD SCREW 3 x 1 x 32 MM		16X
HW3	FLAT HEAD SCREW 3 x 1 x 19 MM		8X
HW4	FLAT HEAD SCREW 3 x 1 x 16 MM		6X

Product Dimensions: 18"W x 15 1/2"D x 23 1/32"H



### **WARNING**

**WEIGHT CAPACITY: TOP: 50 LBS; DRAWER: 15 LBS**  
**WARNING: DO NOT STAND ON THE NIGHTSTAND**  
**WARNING: DO NOT OVER TORQUE BOLTS/SCREWS**

PIECE	DESCRIPTION	PICTURE	QUANTITY
HW5	CAMBOLT		12X
HW6	CAMLOCK		12X
HW7	WEDGE		6X
HW8	DOWEL		8X
HW9	SPRING WASHER		8X
HW10	ALLEN KEY		1X

## PREPARATION

- \* Before beginning assembly of product, make sure all parts are present. Compare parts with package contents list and hardware contents list.
- \* If any part is missing or damaged, do not attempt to assemble the product.
- \* Estimated Assembly Time: 60 minutes.
- \* Tools Required for Assembly : Allen Key (included), Phillips screwdriver (not included)
- \* If you are having difficulty, our friendly Customer Care team is always here to help.

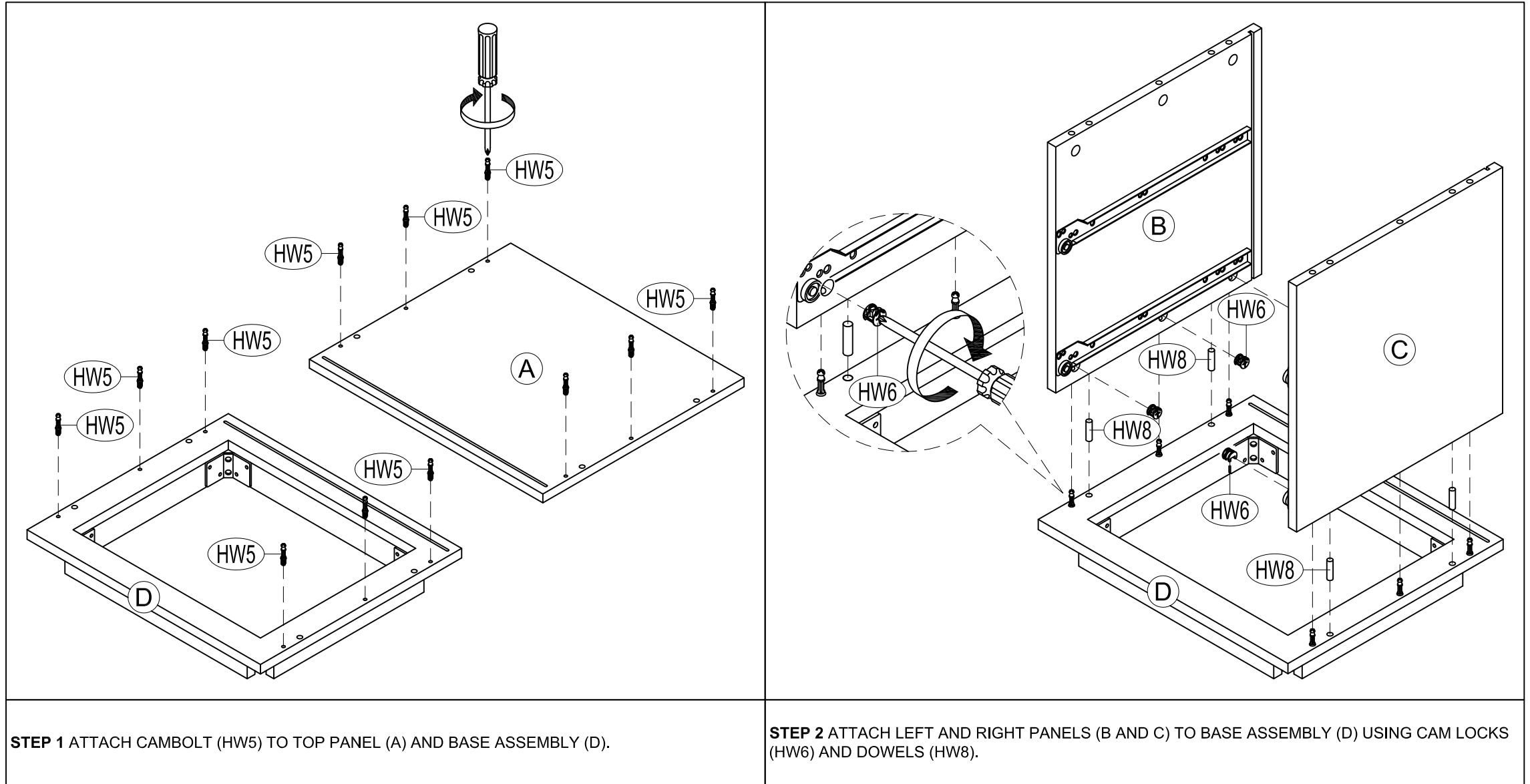

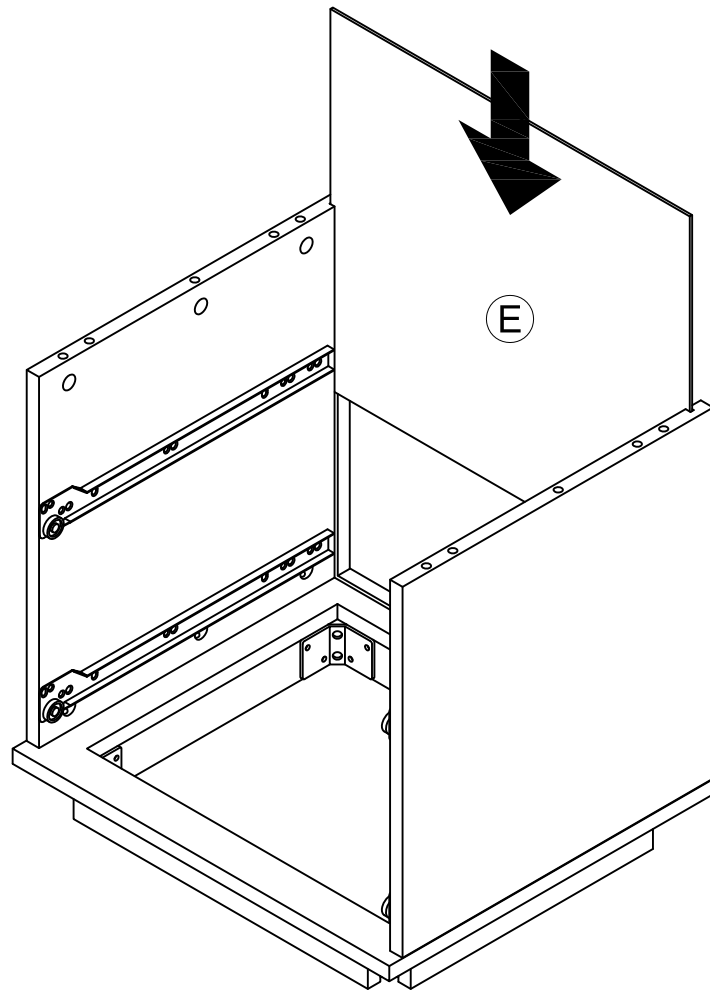

**STEP 3** SLIDE BACK PANEL (E) TO UNIT.

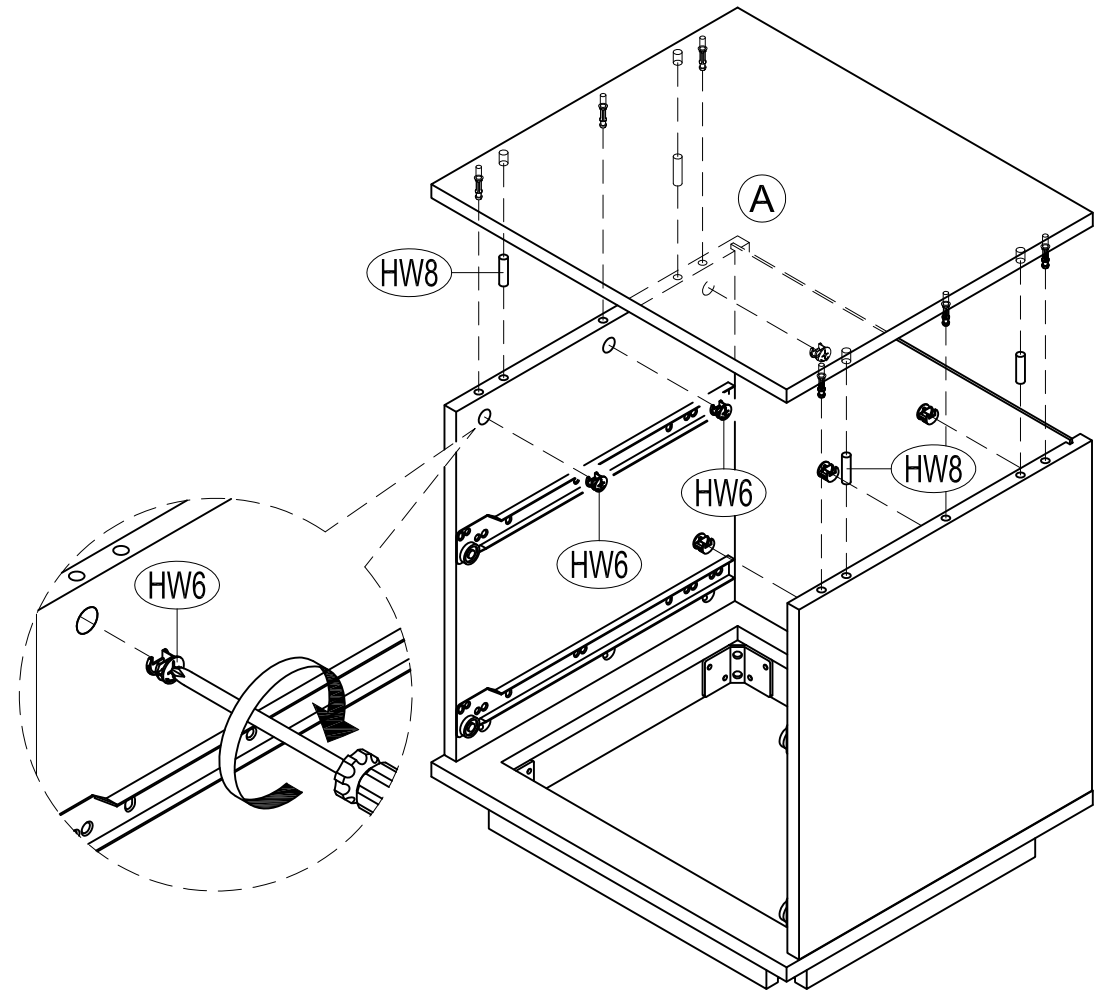

**STEP 4** ATTACH TOP PANEL (A) TO UNIT USING CAMLOCKS (HW6) AND DOWELS (HW8).

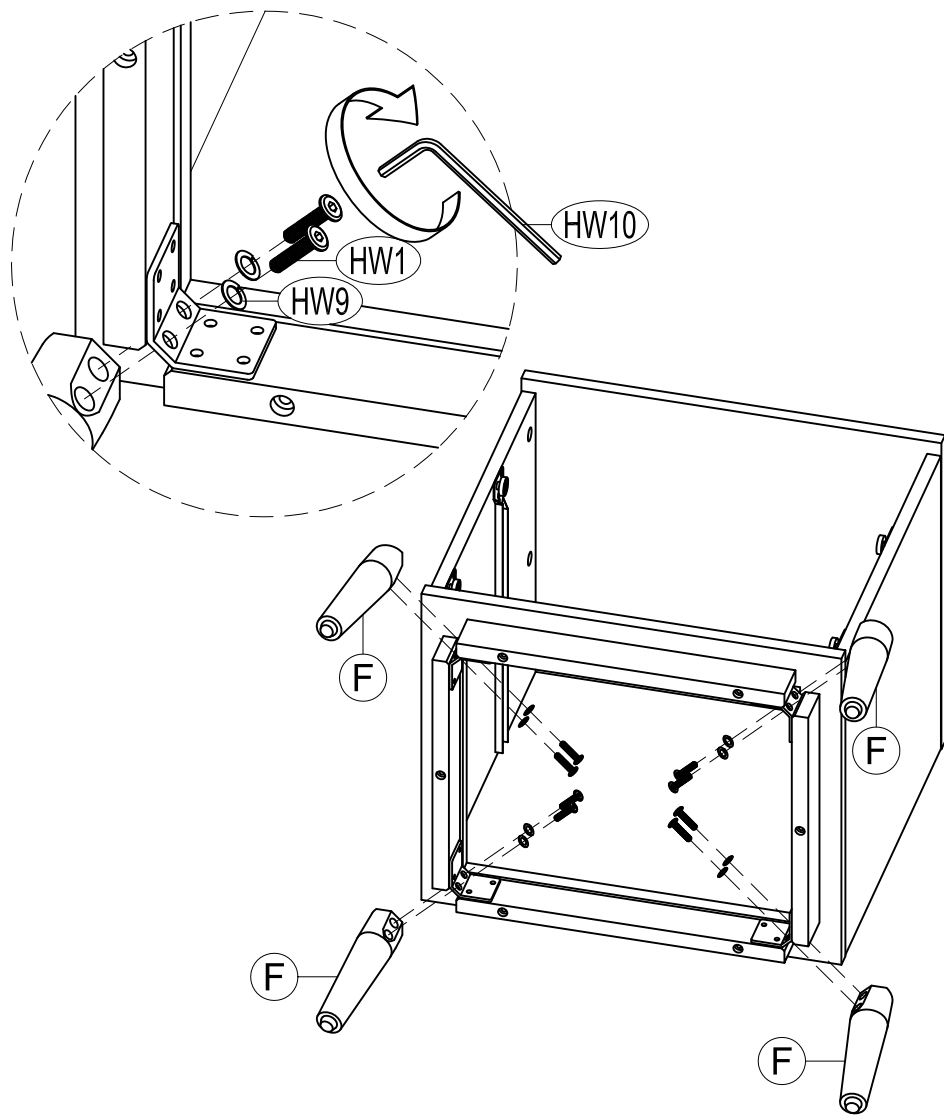

**STEP 5** ATTACH LEGS (F) TO UNIT USING BOLTS (HW1) AND SPRING WASHERS (HW9). TIGHTEN BOLTS (HW1) USING ALLEN KEY (HW10).

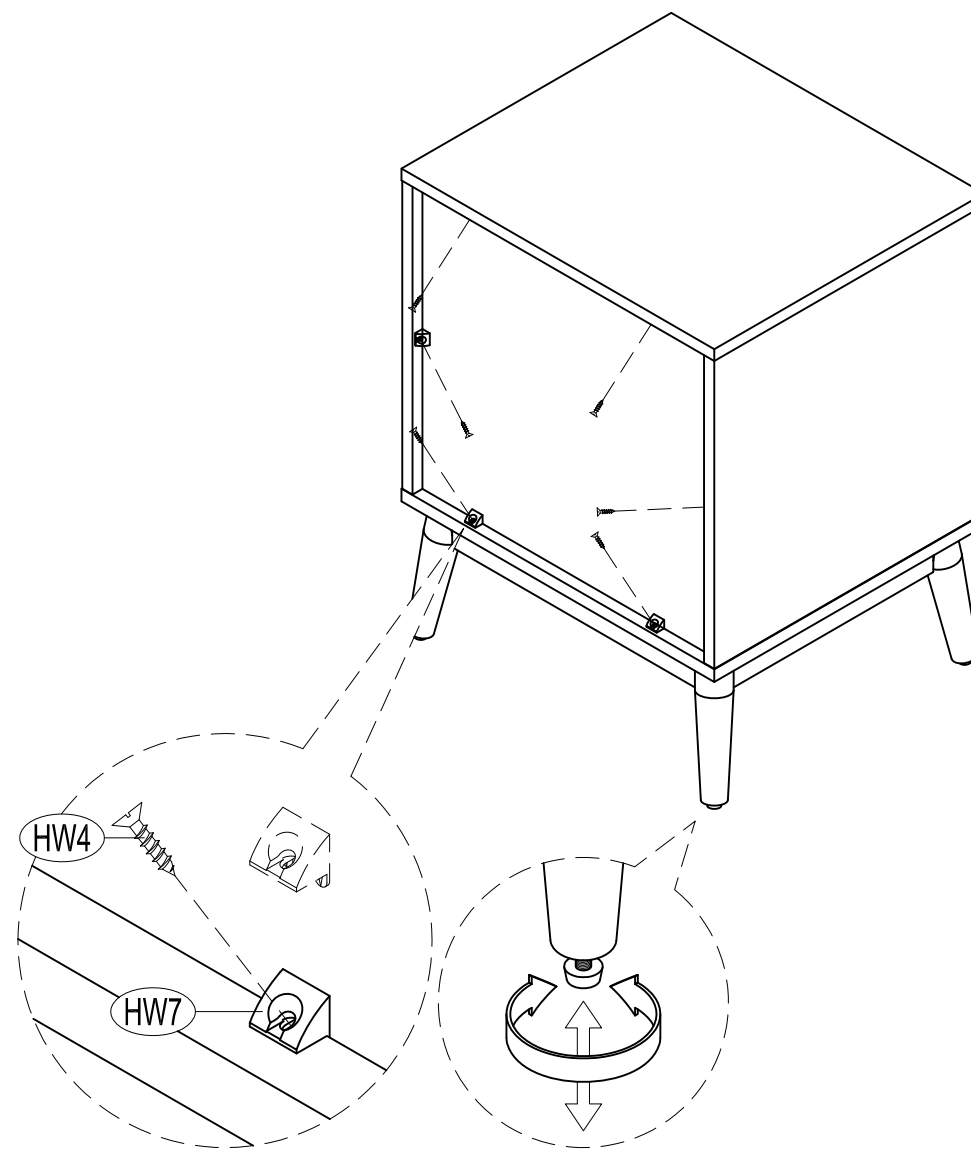

**STEP 6** ATTACH WEDGES (HW7) TO LOCK BACK PANEL USING FLAT HEAD SCREWS 16 MM (HW4). ADJUST THE ADJUSTER BOLT THAT HAS ALREADY ASSEMBLED TO THE LEGS TO STABILIZE YOUR UNIT

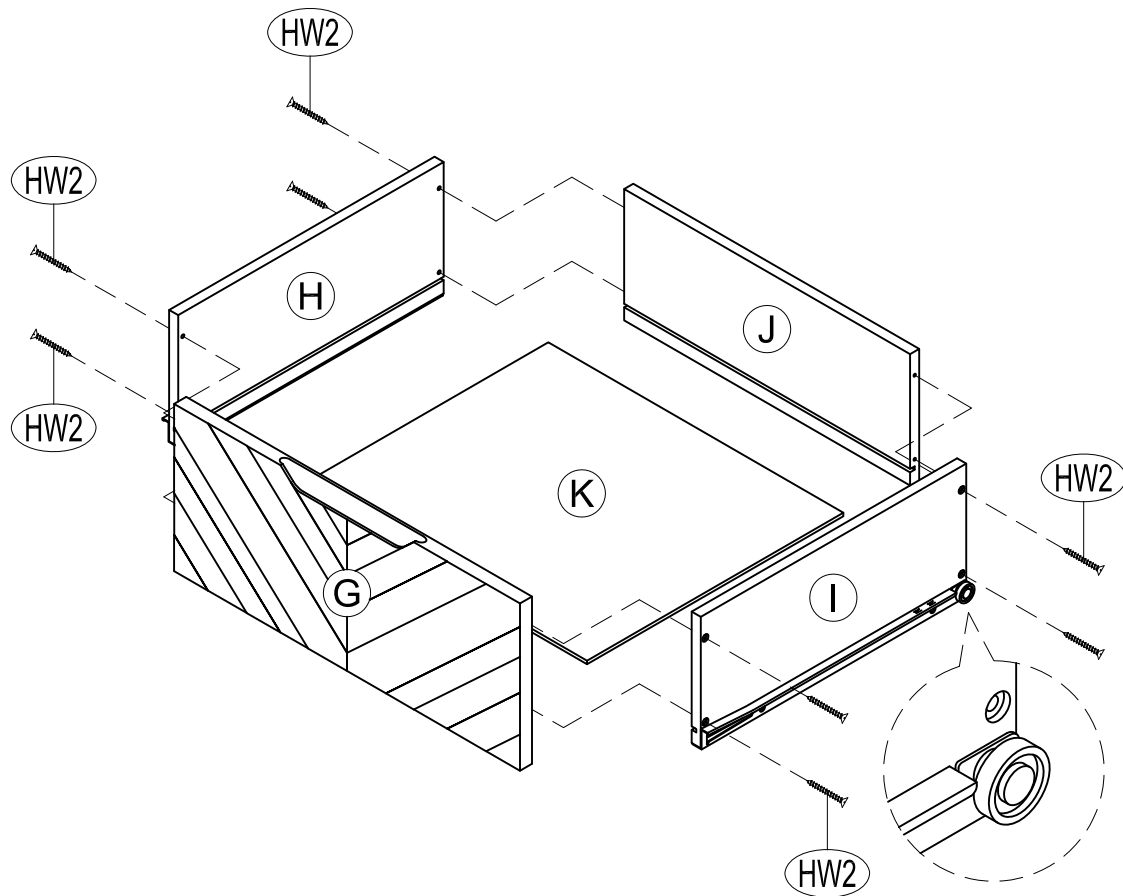

2X

**STEP 7** ATTACH DRAWER LEFT AND RIGHT (H AND I) TO DRAWER BACK (J) USING FLAT HEAD SCREWS 32 MM (HW2). SLIDE DRAWER BASE (K) INTO THE GROOVE. ATTACH DRAWER FRONT (G) TO DRAWER LEFT AND RIGHT (H AND I) USING FLAT HEAD SCREWS 32 MM (HW2).

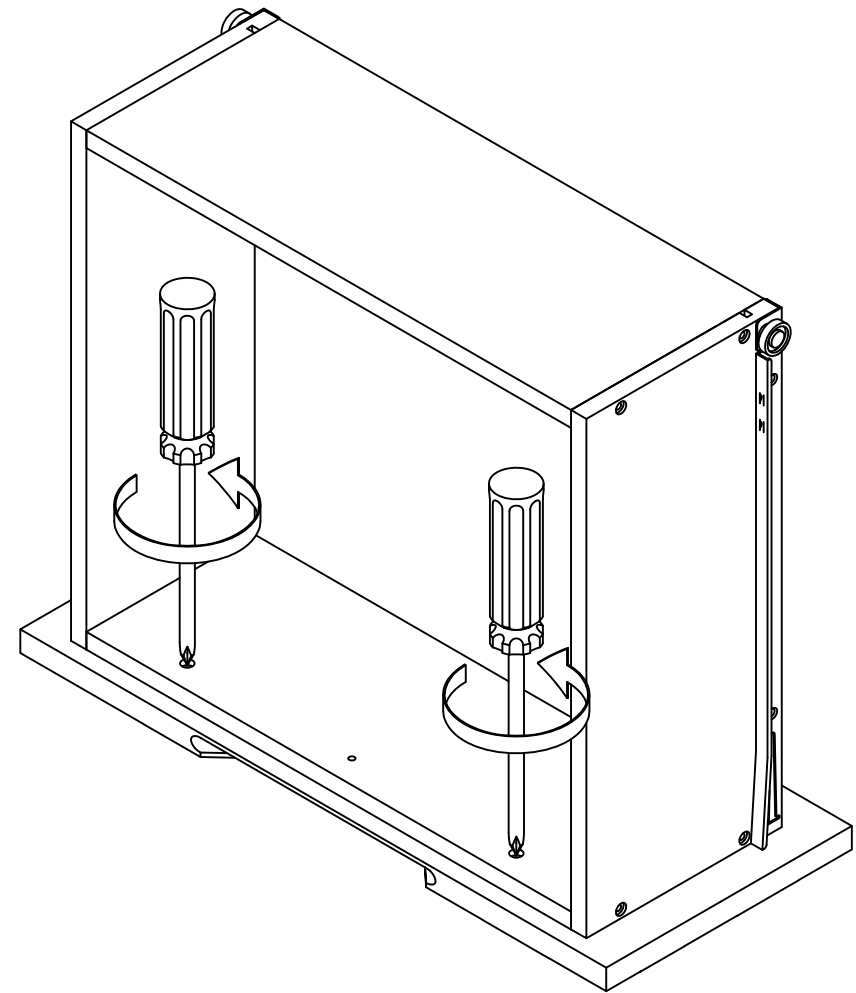

**STEP 8** LOOSEN SLIGHTLY THE SCREWS PRE-INSTALLED ON THE BACK OF THE DRAWER FRONTS.

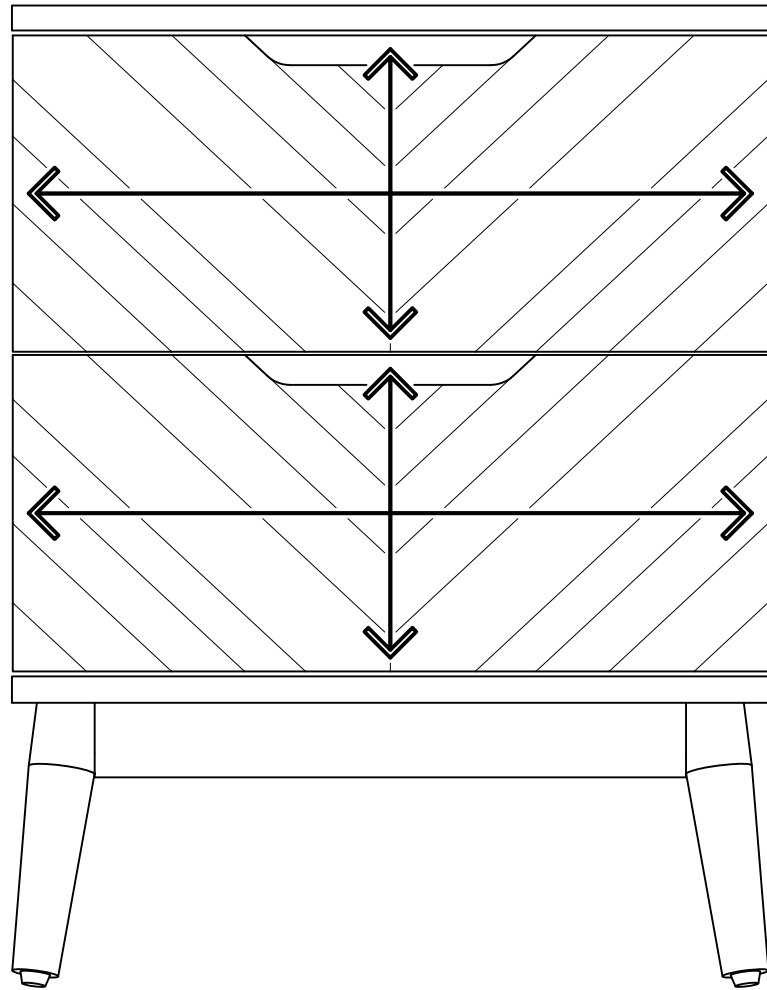

**STEP 9** INSERT THE DRAWER INTO THE UNIT, THEN ADJUST THE DRAWER FRONT PANEL LEFT OR RIGHT AND UP OR DOWN UNTIL THE DRAWER GAPS LOOK PROPORTIONAL.

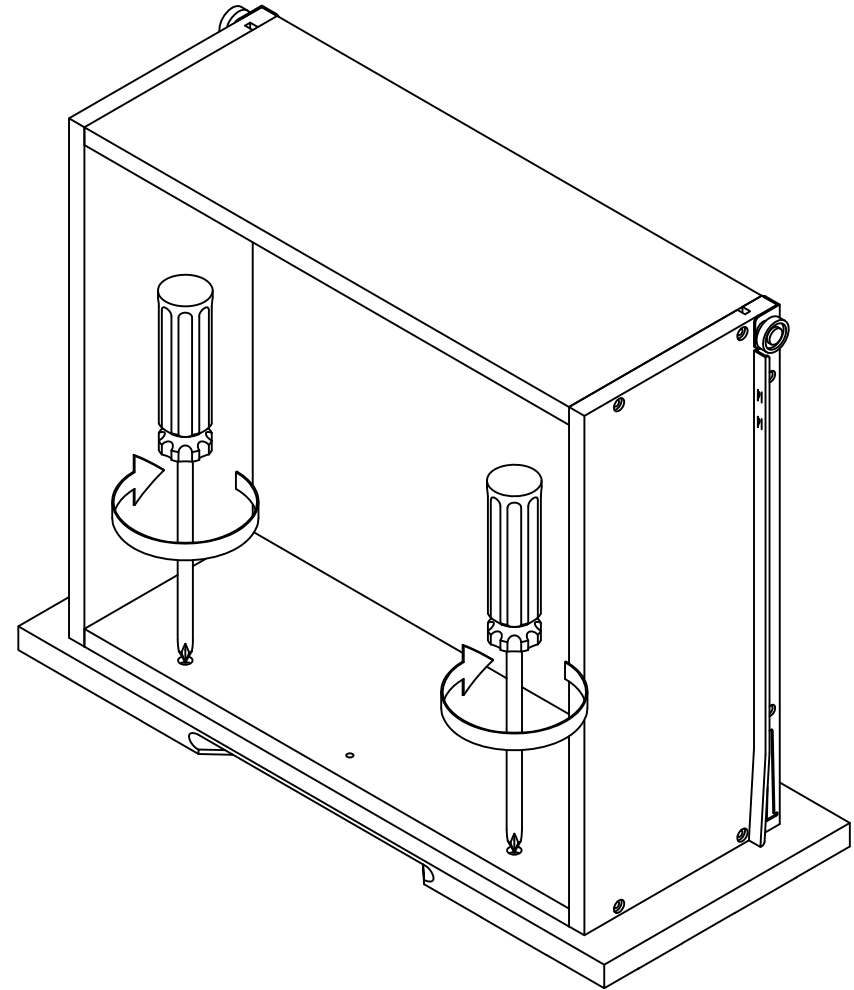

**STEP 10** PULL THE DRAWER OPEN SLOWLY AND RE-TIGHTEN THE SCREWS FROM STEP 8.

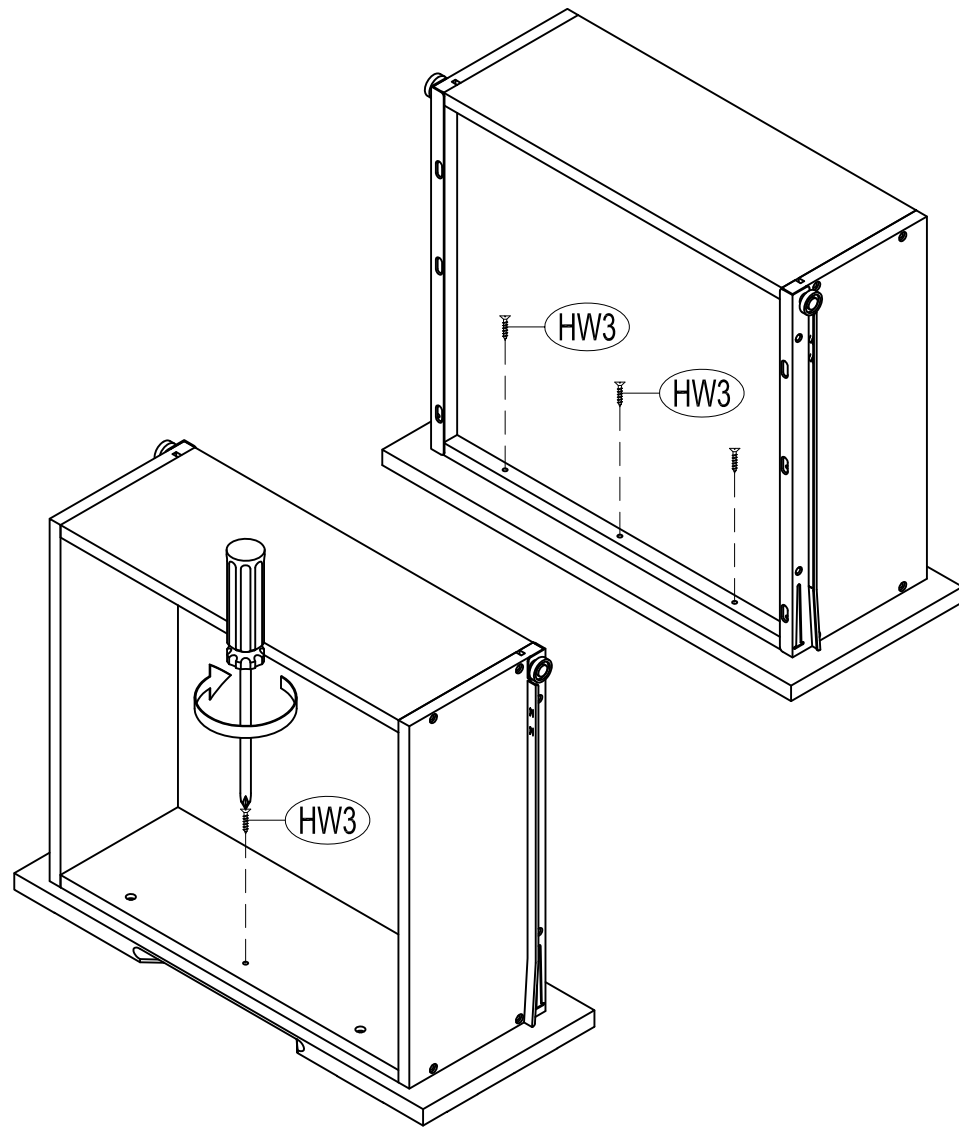

**STEP 11** MAKE SURE THE FRONT PANEL DOES NOT MOVE AND LOCK THE DRAWER FRONT PANEL INTO POSITION WITH FLAT HEAD SCREWS 19 MM (HW3).

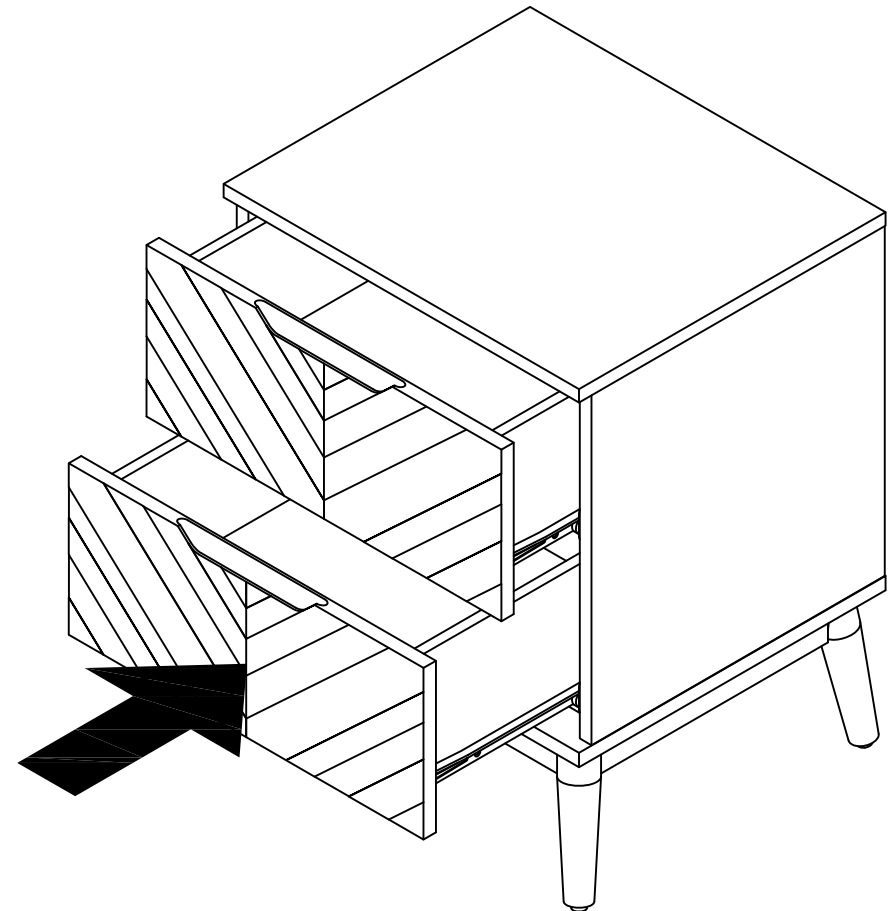

**STEP 12** SLIDE THE DRAWERS INTO UNIT.