



















# Assembly Instructions

**Caution : You must read these Assembly Instructions before you proceed**

## Care & Maintenance

-   ● Not for commercial use. For residential use only.
-   ● Do not put hot items directly on furniture surface.
-   ● Do not clean furniture with harsh cleansers or polish.
-   ● To obtain the longest lifespan of your outdoor products, minimizing exposure to direct sunlight is recommended.
-   ● Children should not climb or jump on the furniture.
-   ● Do not write on furniture without a padded barrier to protect the surface.
-   ● To obtain the longest lifespan of your outdoor products, avoid extended and lengthy exposure to rain, snow, and direct sunshine. Whenever possible cover the product and /or place under patio or awnings.
-   ● Stains may be removed with mild soap solution and damp cloth.
-   ● Dust and pick-up spills using a clean, non-colored, lint-free cloth.

Please look into the **Seat Panel** for hardware packs.

## DAYBED

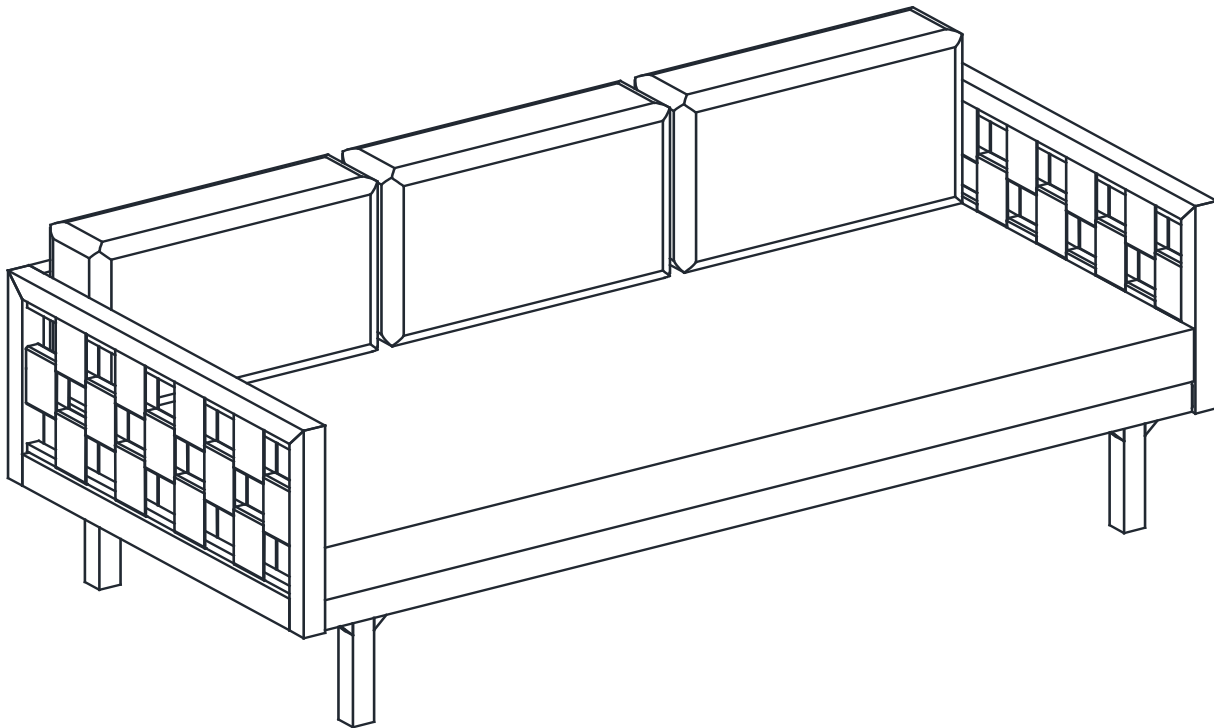

**CAUTION:** This Daybed is NOT a TOY.



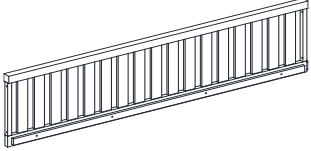
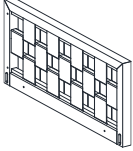
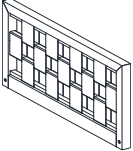
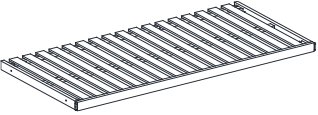
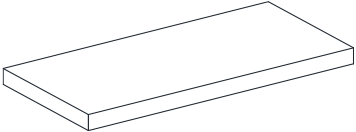
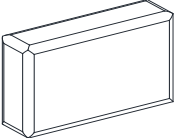

Keep your child / children at bay during the assembly process.

Whenever lifting or moving the Daybed and to prevent any damage to it, two adults may be needed to execute these actions.

## Part List

Label	Picture	Description	QTY
A		Backrest Panel	1
B		Right Side Panel	1
C		Left Side Panel	1
D		Seat Panel	1
E		Legs	4
F		Seat Cushion	1
G		Backrest Cushion	3

## Hardware

Label	Picture	Description	QTY
①		Bolt (M6x35mm)	9
②		Bolt (M6x45mm)	5
③		Screws (M6x40mm)	13
④		Allen Wrench	1

# Assembly Preparation

Before Beginning Assembly:

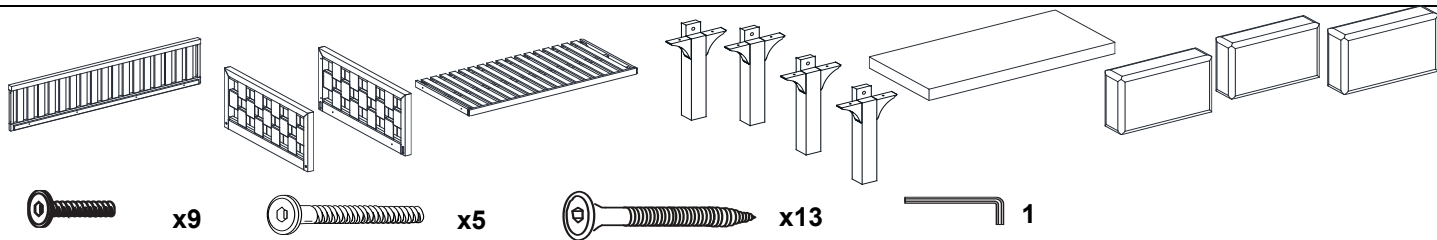

Read instructions, cover to cover-

Have 2 adults an hand for assembly-

Do not assemble on flooring or carpet-

Assemble on a clean non-marring surface (packing foam)-

Save all packaging until finished-

# Assembly Steps

## Overview

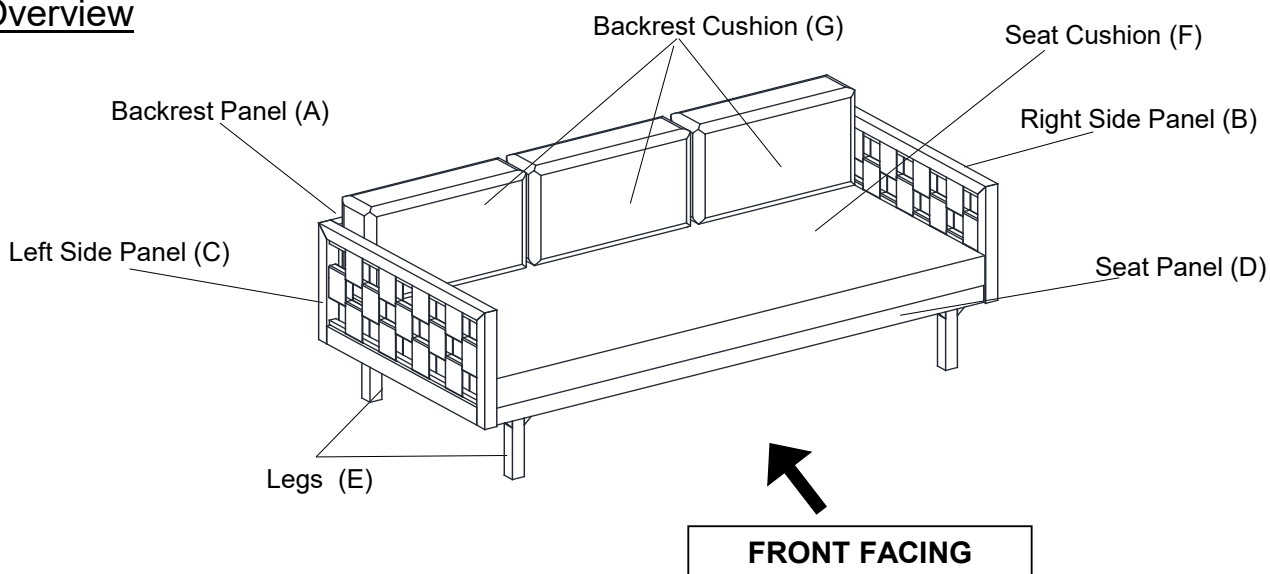

This Daybed has multiple parts and may require up to 30 minutes to assemble. To give you an overview of the Daybed parts, the above picture is provided to help you put the various parts into perspective. Please read through the instructions below to familiarise yourself with the parts and steps before assembly.



Unpack and place all parts on a clean, non-marring surface.

### Step 1

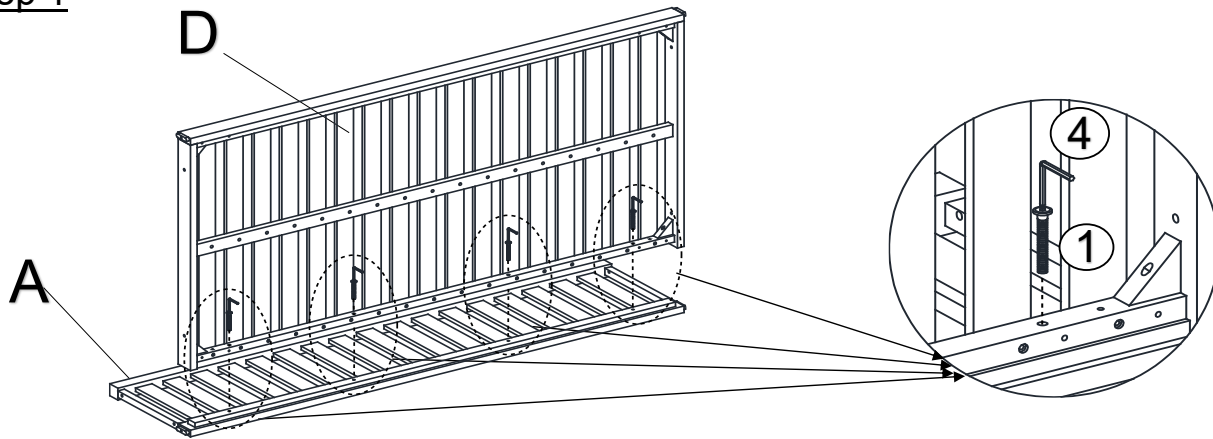

Place the Backrest Panel (A) lie onto a clean, non-marring surface, with the assistance from your adult partner.

Attach Backrest Panel (A) to Seat Panel (D) by using Bolt (①) with Allen Wrench (④) as shown above.

**Do not fully tighten the Bolts at this time.**

### Step 2

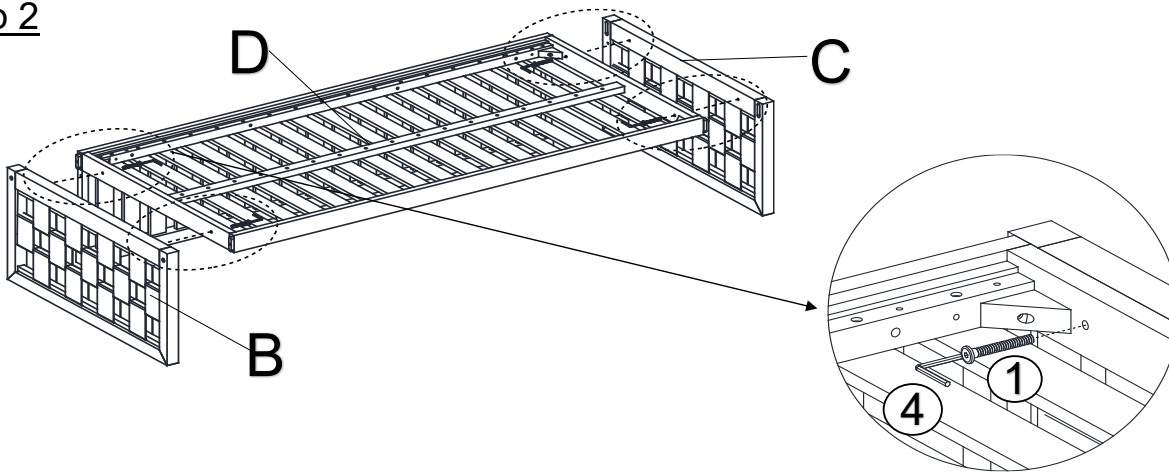

Turn up the assembled part in Step 1 on the ground as shown above, with the assistance from your adult partner.

Attach the Right Side Panel (B) & Left Side Panel (C) to assembled frame in step 1 by using Bolts (①) with Allen Wrench (④) as shown above.

**Do not fully tighten the Screws at this time**

### Step 3

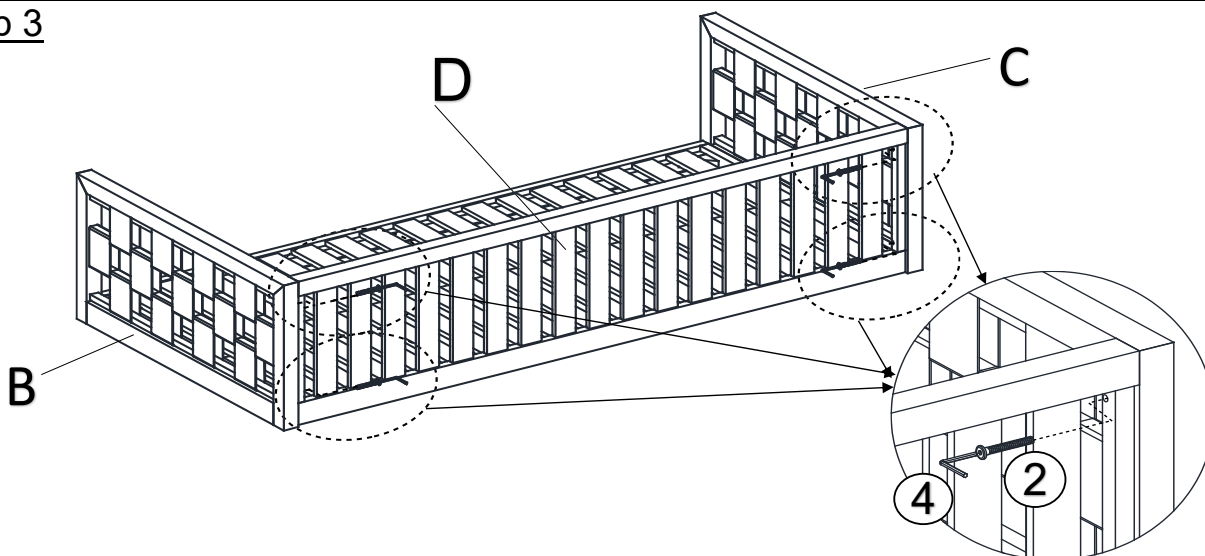

Place the the assembled part in Step 2 facedown onto a clean, non-marring surface, with the assistance from your adult partner.

Attach the Seat Panel (D) to Right Side Panel (B) & Left Side Panel (C) by using Bolt(②) and Allen Wrench (④) as shown above.

**Do not fully tighten the Bolts at this time**

## Step 4

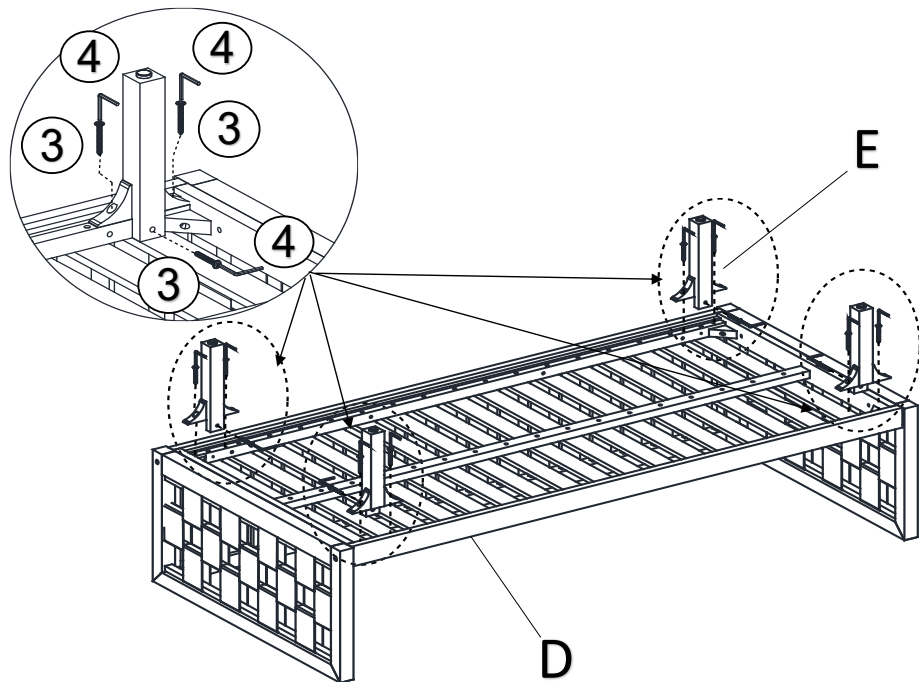

Place the the assembled part in Step 3 facedown onto a clean, non-marring surface, with the assistance from your adult partner.  
Attach the Seat Panel (D) to Legs (E) by using Screws (③) with Allen Wrench (④) as shown above.  
**Do not fully tighten the Bolts at this time**

## Step 5

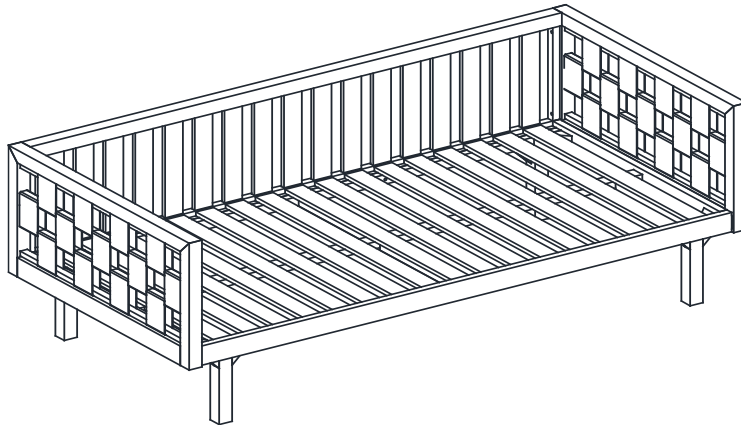

Turn the Daybed right side up.  
Inspect the Daybed and make sure all parts are adequately connected.  
In a sequential manner, tighten all Screws and Bolts at all joints.  
Place the Daybed on a flat, level surface to make sure it is balance  
**CAUTION: When tightening these screws and bolts, tighten sequentially.**  
**DO NOT** tighten any screw or bolt fully and then move towards the next one. This could cause the frame to warp.  
**WARNING!! IF THE DAYBED IS NOT STABLE, IT COULD LEAD TO DAMAGING THE PRODUCT.**

## Step 6

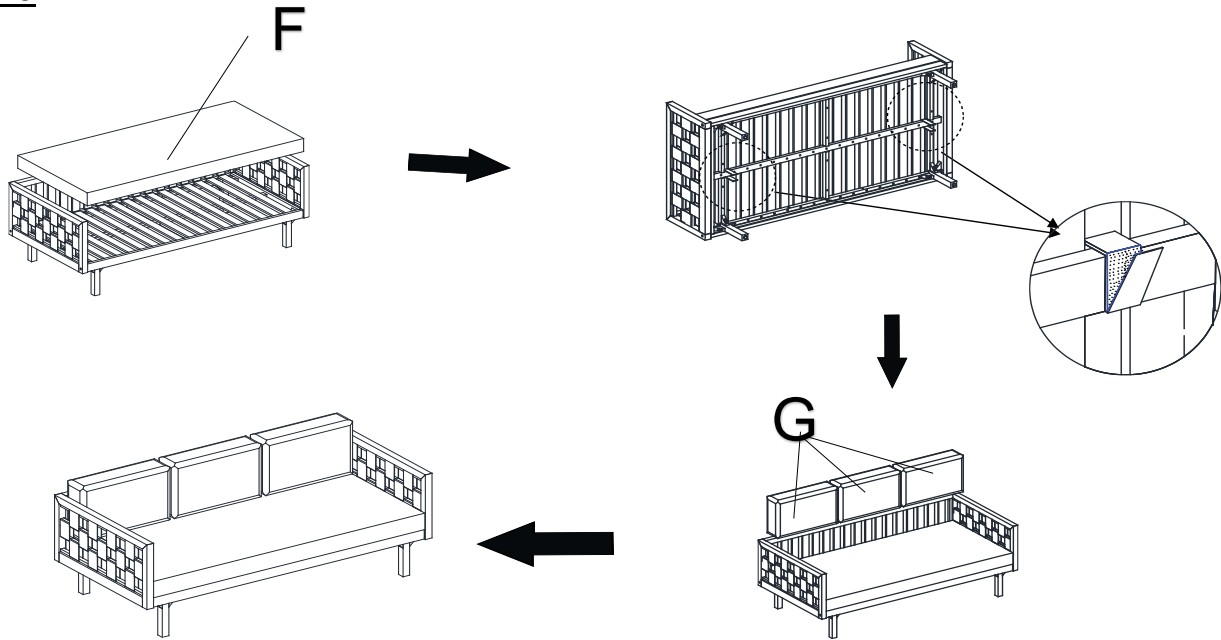

Place the Seat Cushion (F) into the Daybed, then affix the "magic tape straps" around the Daybed as shown above.

Place the Backrest Cushion (G) into the Daybed as shown above **Your Daybed is ready to be used.**

**This Daybed can only be used on a flat, level surface.**

## Questions & Answers about Proposition 65

- What is Proposition 65?

Proposition 65 requires businesses to provide warnings to Californians about significant exposures to chemicals that cause cancer, birth defects or other reproductive harm. These chemicals can be in the products that Californians purchase, in their homes or workplaces, or that are released into the environment. By requiring that this information be provided, Proposition 65 enables Californians to make informed decisions about their exposures to these chemicals.

Proposition 65 also prohibits California businesses from knowingly discharging significant amounts of listed chemicals into sources of drinking water.

Proposition 65 requires California to publish a list of chemicals known to cause cancer, birth defects or other reproductive harm. This list, which must be updated at least once a year, has grown to include approximately 900 chemicals since it was first published in 1987.

- What types of chemicals are on the Proposition 65 list?

The list contains a wide range of naturally occurring and synthetic chemicals that include additives or ingredients in pesticides, common household products, food, drugs, dyes, or solvents. Listed chemicals may also be used in manufacturing and construction, or they may be byproducts of chemical processes, such as motor vehicle exhaust.

- What does a warning mean?

If a warning is placed on a product label or posted or distributed at a workplace, a business, or in rental housing, the business issuing the warning is aware or believes that it is exposing individuals to one or more listed chemicals.

By law, a warning must be given for listed chemicals unless the exposure is low enough to pose no significant risk of cancer or is significantly below levels observed to cause birth defects or other reproductive harm.

- Where can I get more information on Proposition 65?

If you have specific questions on the administration or implementation of Proposition 65, you can contact OEHHA's Proposition 65 program at [P65.Questions@oehha.ca.gov](mailto:P65.Questions@oehha.ca.gov), or by phone at (916) 445-6900.