

ASSEMBLY INSTRUCTIONS

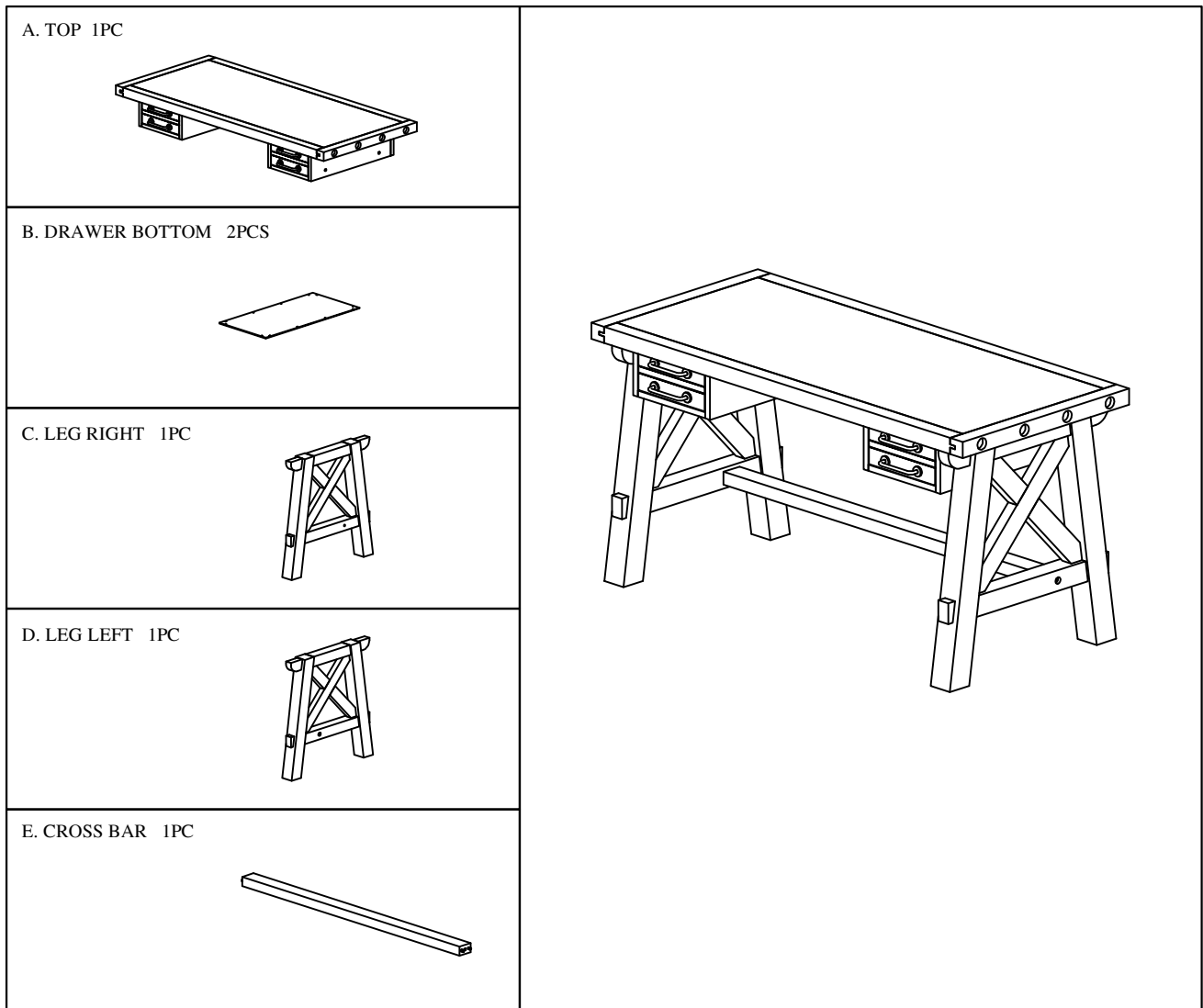

HARDWARE ENCLOSED IN BOX

1	ALLEN BOLT M8 x 40 MM	08 PCS	2	ALLEN BOLT M8 x 60 MM	02 PCS	3	WASHER M9/22	08 PCS	4	SPRING WASHER M9/11	08 PCS	5	HALF MOON WASHER	02 PCS
6	SPANNER N13	01 PC	7	SCREW M4 x 15 MM	24 PC	8	HANDLE	4 PCS	9	ALLEN BOLT M4 x 35 MM	08 PCS			

TOOL REQUIRED

PHILLIPS HEAD SCREW
DRIVER NOT PROVIDED

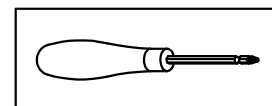

STEP 1:

ON A FLAT, LEVEL AREA LAY DOWN A CLEAN BLANKET OR A TOWEL TO PLACE THE TOP (A) UPSIDE DOWN ON. OPEN BOTH SETS OF DRAWERS TO FULL EXTENSION. ATTACH THE LEG RIGHT (C) TO THE TOP (A) USING FOUR M8X40 ALLEN BOLTS (1), SPRING WASHERS (4) AND FLAT WASHERS (3). DO NOT TIGHTEN THE BOLTS COMPLETELY.

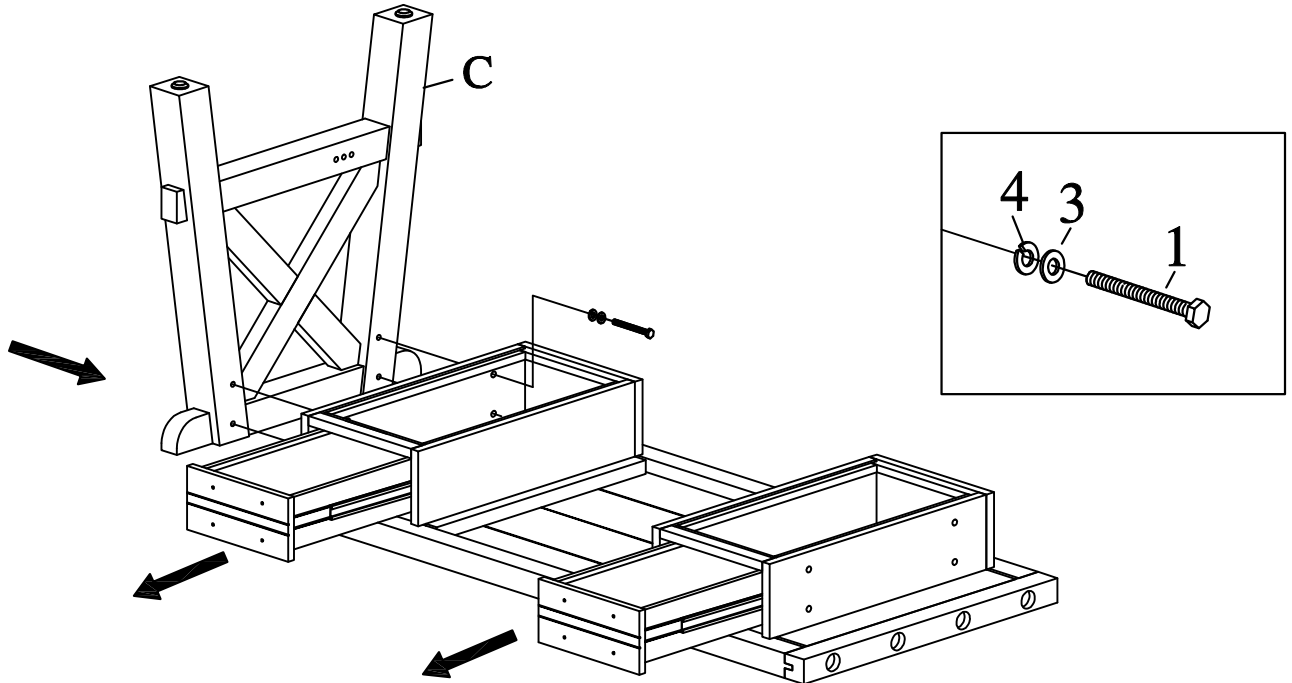

STEP 2:

ATTACH THE CROSS BAR (E) TO THE LEG RIGHT (C) USING ONE HALF MOON WASHER (5) AND M8X60 ALLEN BOLT (2). TIGHTEN USING THE PROVIDED SPANNER (6). DO NOT TIGHTEN COMPLETELY.

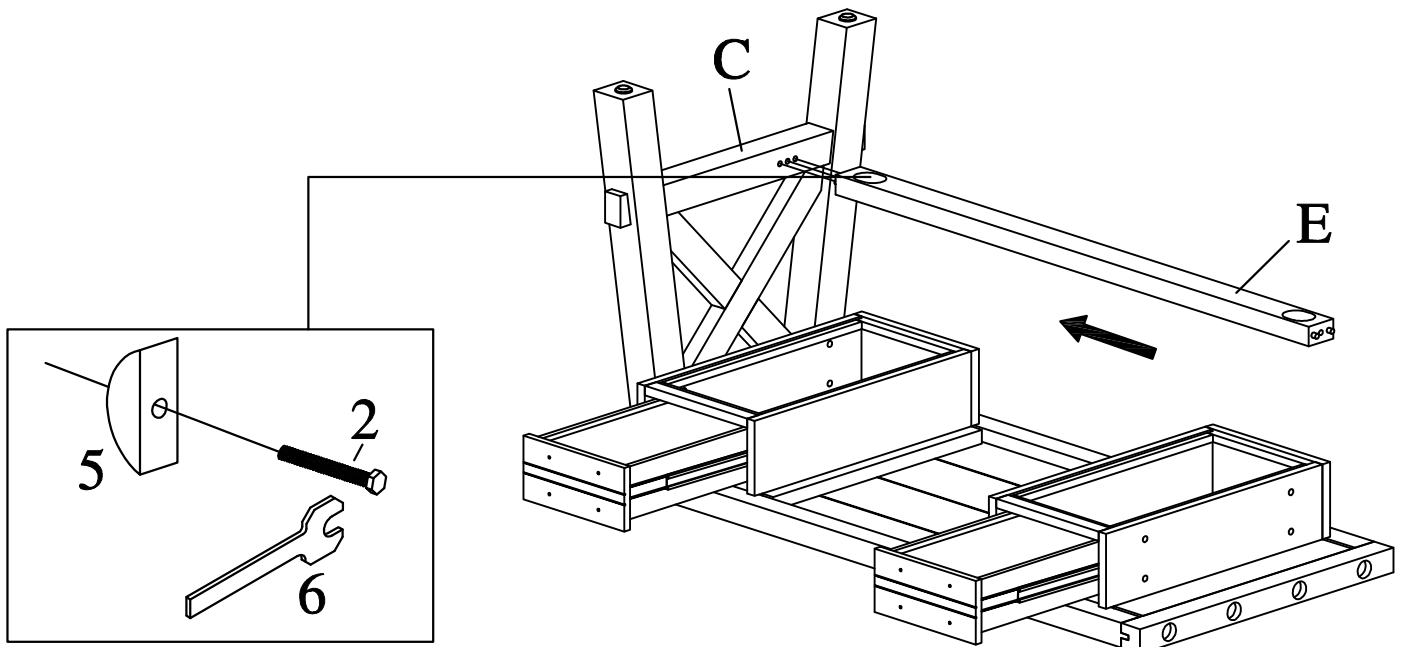

STEP 3:

ATTACH THE LEG LEFT (D) TO THE TOP (A) USING FOUR M8X40 ALLEN BOLTS (1), SPRING WASHERS (4) AND FLAT WASHERS (3). FASTEN THE CROSS BAR (E) TO THE LEG LEFT (D) USING ONE HALF MOON WASHER (5) AND M8X60 ALLEN BOLT (2). TIGHTEN USING THE PROVIDED SPANNER (6). TIGHTEN THE BOLTS FROM STEP 1 AND EARLIER IN STEP 3 BEFORE CONTINUING TO STEP 4.

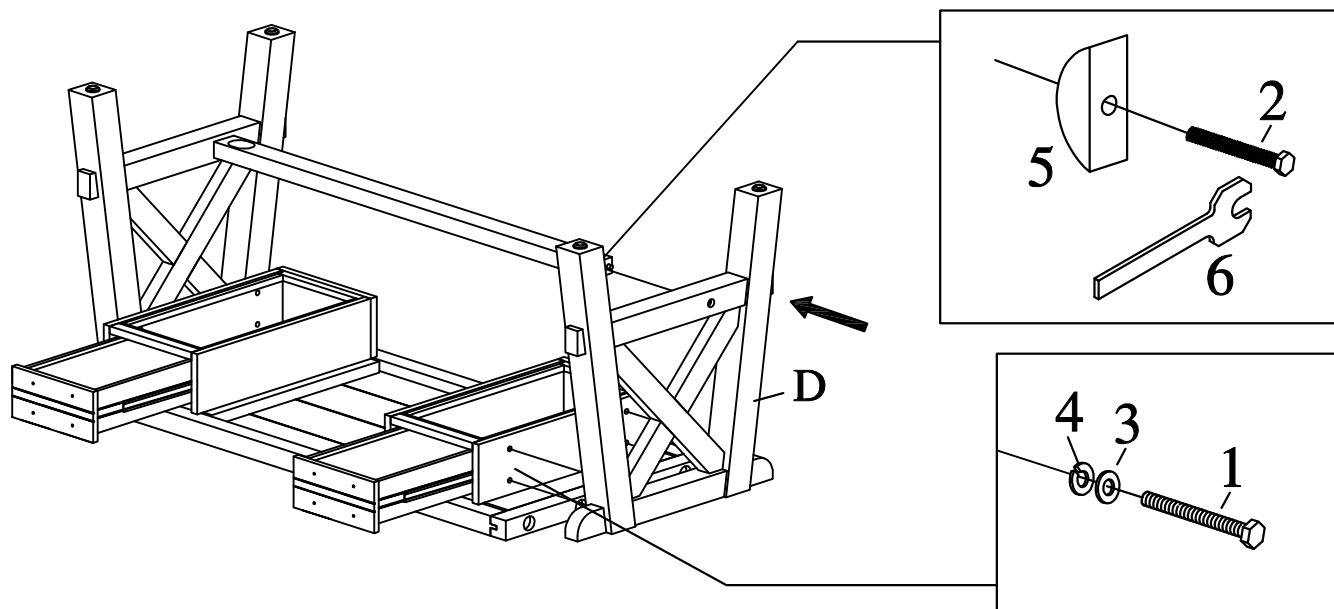

STEP 4:

ATTACH THE DRAWER BOTTOM (B) TO THE FRAME DRAWERS ON THE UNDERSIDE OF THE TOP (A) USING 24 SCREWS PER DRAWER.

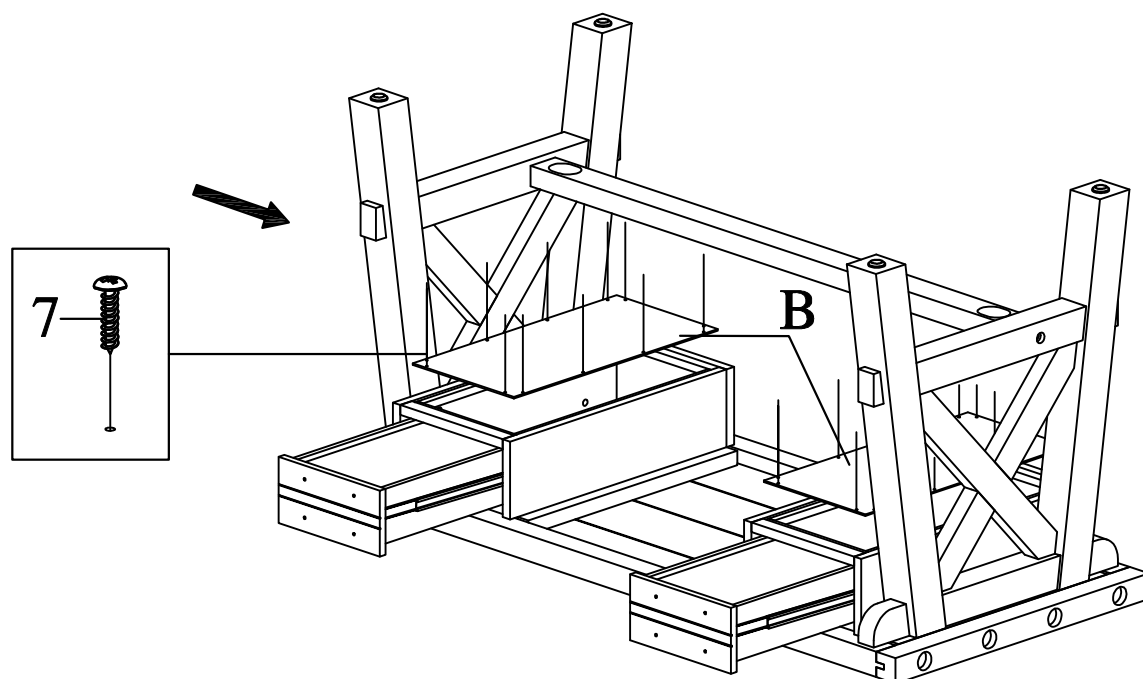

STEP 5:

WITH HELP FROM ANOTHER PERSON, FLIP THE DESK ONTO ITS LEGS.

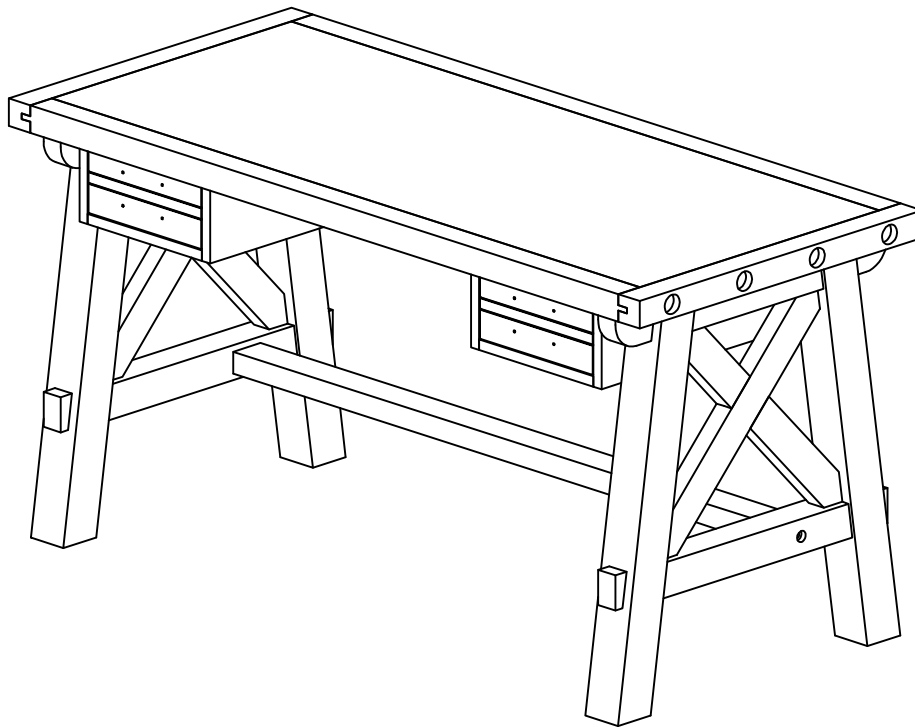

STEP 6:

ATTACH THE HANDLES (8) TO THE DESK DRAWERS USING EIGHT M4X35 ALLEN BOLTS (9).

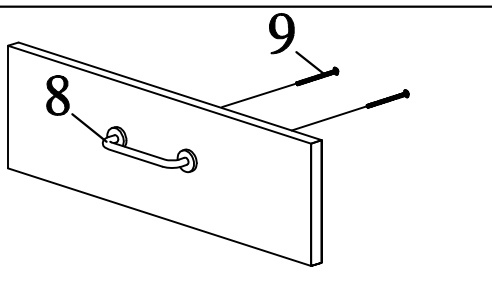
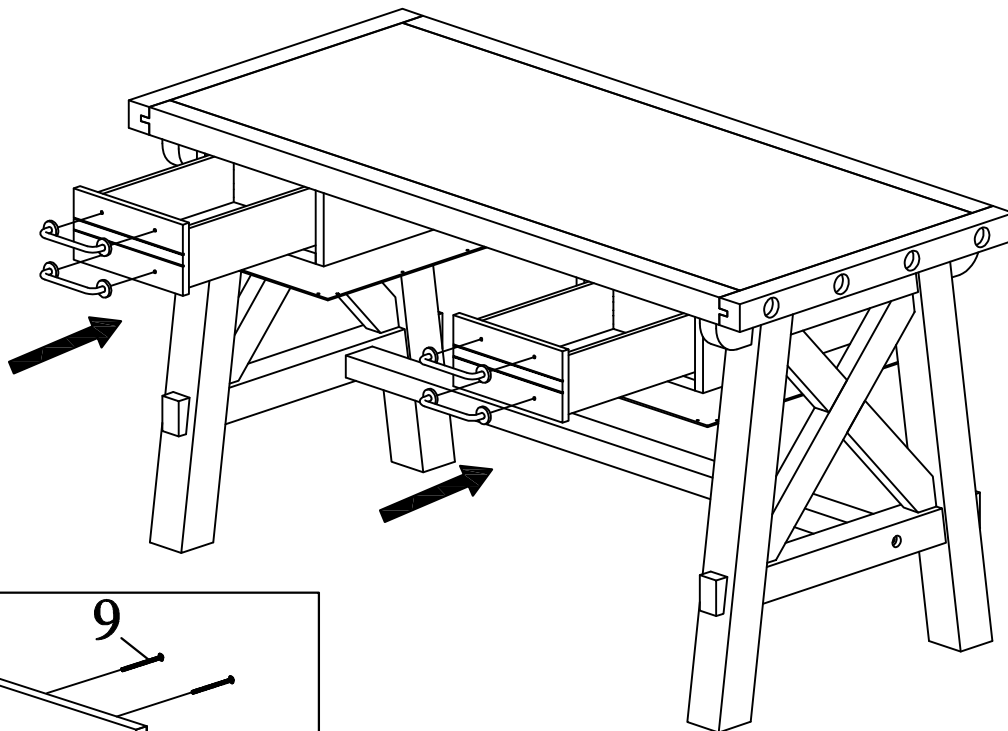

ASSEMBLY COMPLETE.