

For a Hassle-Free Installation

1. Ensure you have received all cartons and familiarize yourself with the workload. Make sure there are enough helping hands to assist you, and that you have allocated the time required to assemble your new product.
 2. Make sure you have cleared enough space in your home for the assembly. We recommend protecting your floor with a mat or cardboard to avoid scratches during the assembly process.
 3. Read instructions carefully and check no parts are missing.
 4. Lay out all hardware on a soft surface so you can easily identify them.
 5. Carefully identify all components according to the labeled alphabet to ensure that the parts are in the correct place.
 6. Install your new product carefully following the instructions. Don't skip ahead!
- * If any parts are missing or damaged, we will gladly ship you replacement parts free of charge. Please contact us order ID and the Store Name of your purchase, we're always here to help :)

WARNING

Serious or fatal injury may occur from unexpected assembly or use.

1. During the assembly process, keep all parts away from babies or children.
2. Always securely fix this product to the wall. Make sure the wall area to be drilled is free from hidden electrical wires, water and gas pipes.
3. Use of tip-over restraints may only reduce, but not eliminate the risk of tip-over.
4. Unless specially designed to accommodate, do not set heavy objects on top of this product.
5. Place the heaviest items on the lowest shelf.
6. Never allow children to climb or bang on drawers, doors or shelves.



WARNING



Children have died from furniture tipover. To reduce the risk of furniture tipover:

- **ALWAYS** install tipover restraint provided.
- **NEVER** allow children to stand, climb or hang on drawers, doors, or shelves.
- **NEVER** open more than one drawer at a time.
- Place heaviest items in the lowest drawers.

Parts List (EN) / Teile Liste (DE)

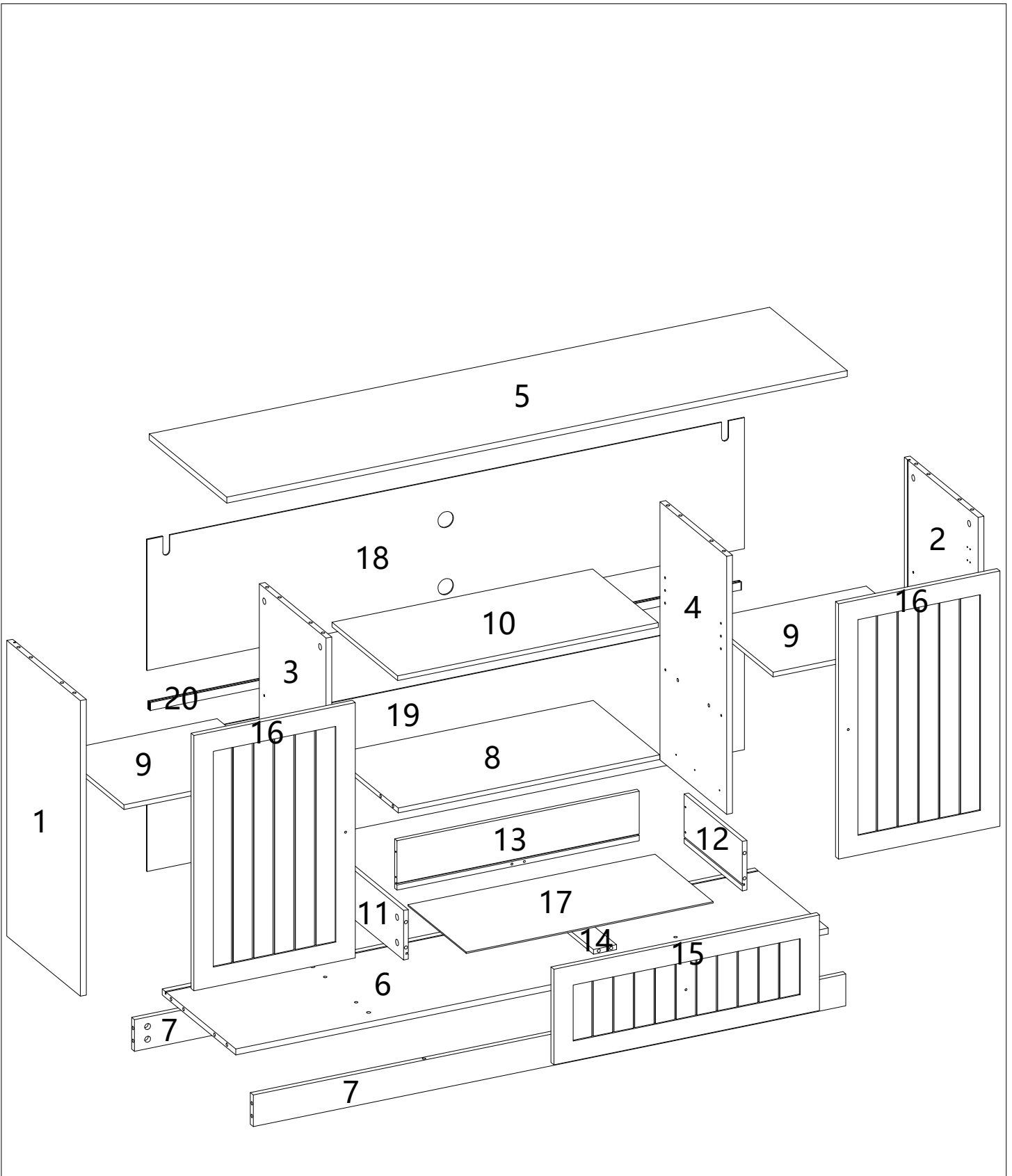

Please don't install it until you received both packages.

Parts List (EN) / Teile Liste (DE)

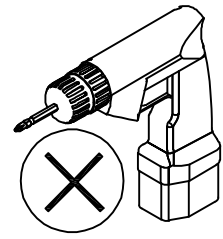
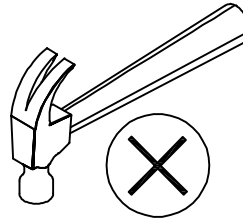
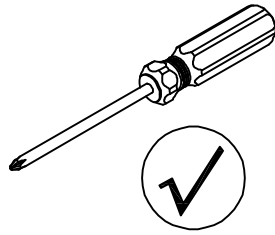
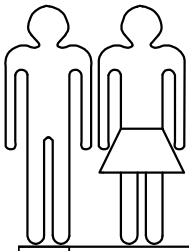

<p>1</p> <p>747*380*15mm</p> <p>1PC</p>	<p>2</p> <p>747*380*15mm</p> <p>1PC</p>	
<p>3</p> <p>the other side</p> <p>one side</p> <p>652*344*15mm</p> <p>1PC</p>	<p>4</p> <p>the other side</p> <p>one side</p> <p>652*344*15mm</p> <p>1PC</p>	
<p>5</p> <p>1600*400*15mm</p> <p>1PC</p>	<p>6</p> <p>the other side</p> <p>one side</p> <p>1528*379.5*15mm</p> <p>1PC</p>	
<p>7</p> <p>1528*80*15mm</p> <p>2PCS</p>	<p>8</p> <p>674*343*12mm</p> <p>1PC</p>	<p>9</p> <p>410*339*12mm</p> <p>2PCS</p>

Parts List (EN) / Teile Liste (DE)

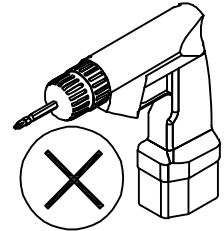
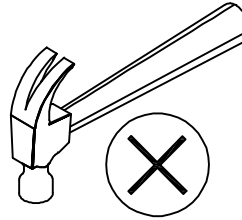
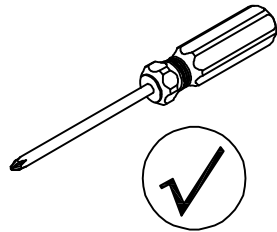
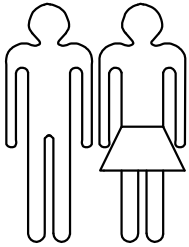

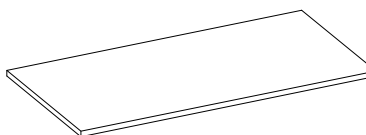
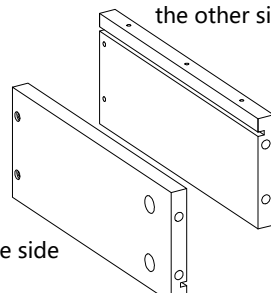
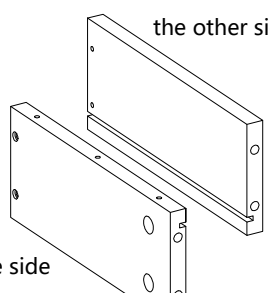
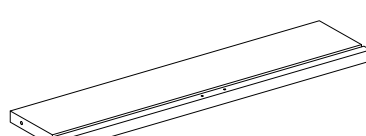
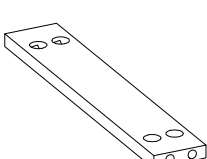
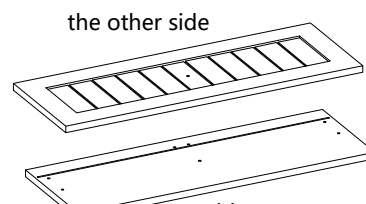
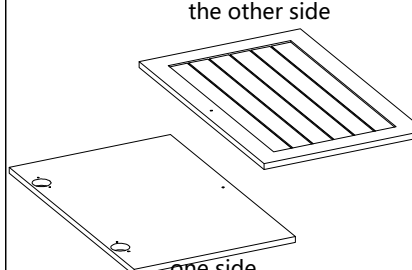
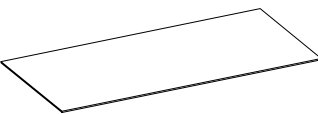
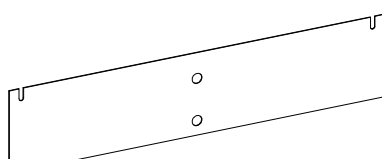
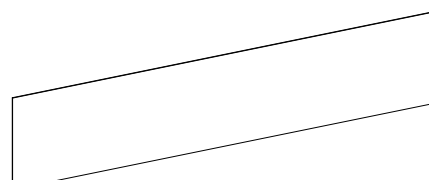
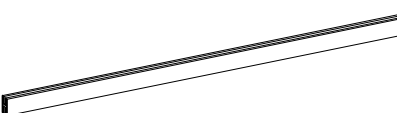
<p>10</p>  <p>672*339*12mm 1PC</p>	<p>11</p>  <p>300*125*12mm 1PC</p>	<p>12</p>  <p>300*125*12mm 1PC</p>
<p>13</p>  <p>625*125*12mm 1PC</p>	<p>14</p>  <p>287*60*12mm 1PC</p>	<p>15</p>  <p>241.5*685*15mm 1PC</p>
<p>16</p>  <p>645*416*15mm 2PCS</p>	<p>17</p>  <p>635*297*3mm 1PC</p>	<p>18</p>  <p>330*1538*3mm 1PC</p>
<p>19</p>  <p>330*1538*3mm 1PC</p>	<p>20</p>  <p>L=1526mm 1PC</p>	

Hardware List (EN) / Teile Liste (DE)

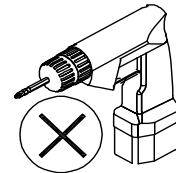
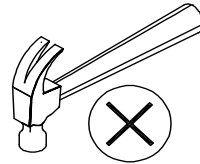
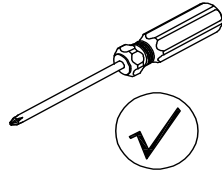
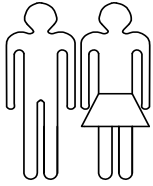

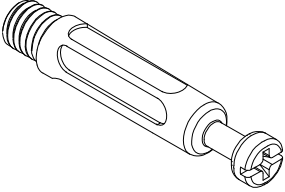
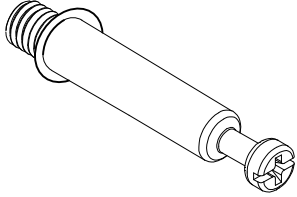
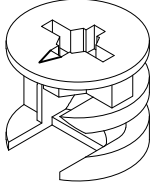
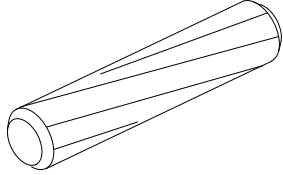
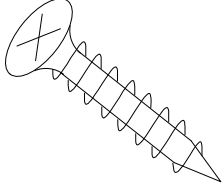
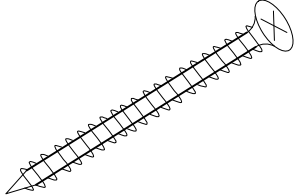
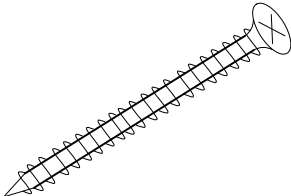
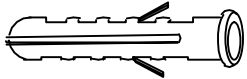
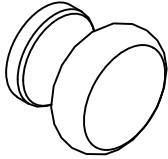
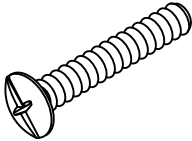
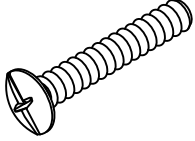
<p>A</p>  <p>ø7*40mm 28PCS</p>	<p>B</p>  <p>ø7*40mm 12PCS</p>	<p>C</p>  <p>ø15*9.5mm 40PCS</p>	<p>D</p>  <p>ø8*30mm 20PCS</p>
<p>E</p>  <p>ø3.5*14mm 46PCS</p>	<p>F</p>  <p>ø3.5*30mm 4PCS</p>	<p>G</p>  <p>ø3.5*40mm 2PCS</p>	<p>H</p>  <p>ø8*40mm 2PCS</p>
<p>I</p>  <p>ø30*26mm 3PCS</p>	<p>J</p>  <p>M4*18mm 2PCS</p>	<p>K</p>  <p>M4*15mm 1PC</p>	

Hardware List (EN) / Teile Liste (DE)

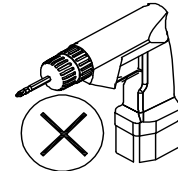
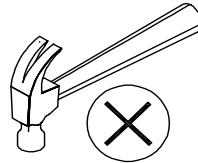
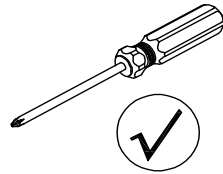
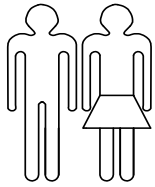

<p>L</p> <p>L=300mm 1PC</p>	<p>M Inset Overlay</p> <p>ø35mm 4PCS</p>	<p>N</p> <p>11*16*15mm 12PCS</p>
<p>O</p> <p>ø13.5 mm 10PCS</p>	<p>P</p> <p>13.5*13*10mm 12PCS</p>	<p>Q</p> <p>70*32*13mm 2PCS</p>
<p>R</p> <p>ø21mm 40PCS</p>	<p>Spare plastic hardware</p> <p>X4 ø5*10mm</p>	

CAM BOLT INSTALLATION AS BELOW:

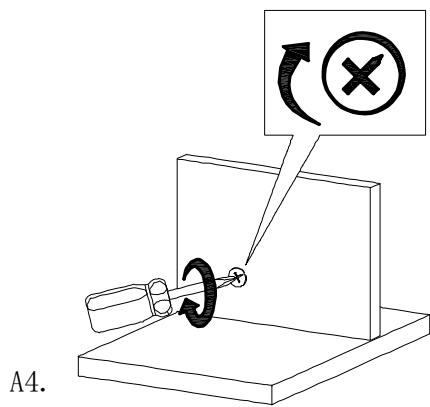
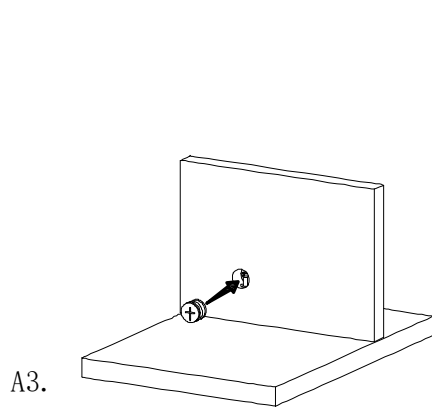
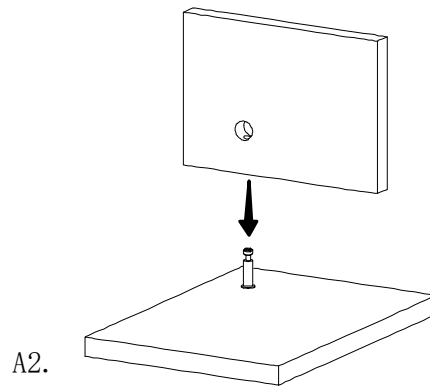
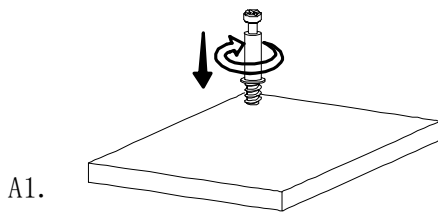
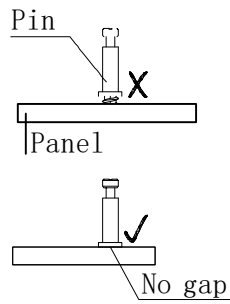
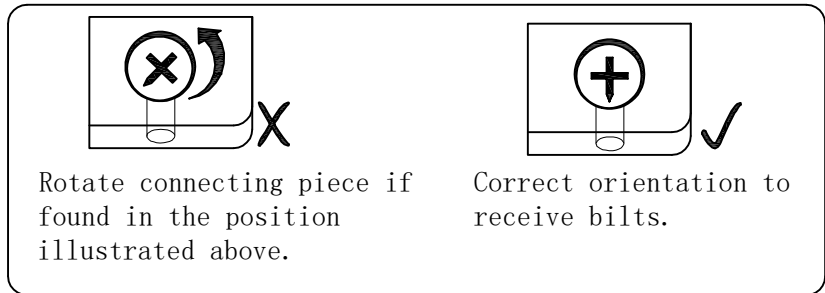
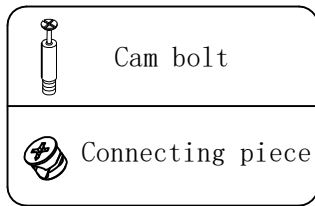

STEP 1

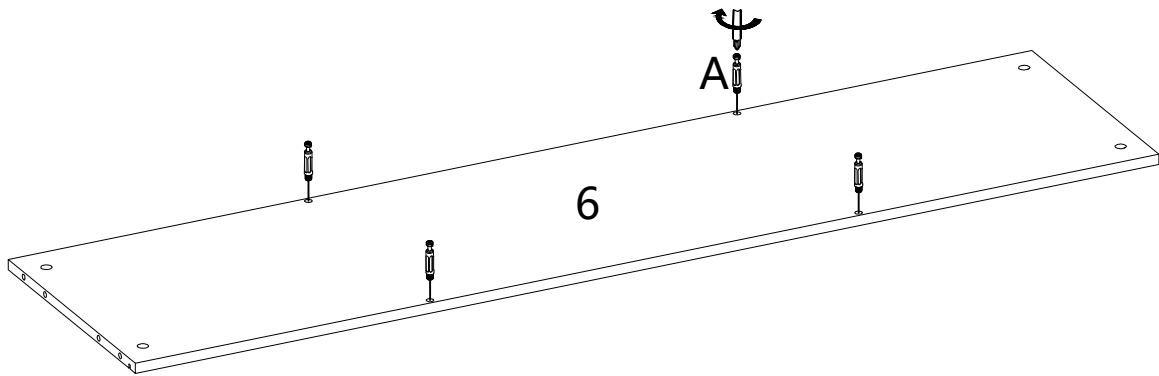
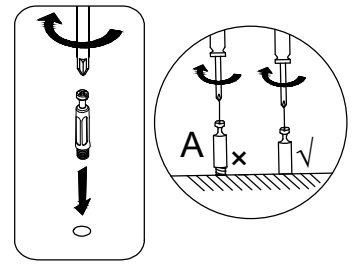

STEP 2

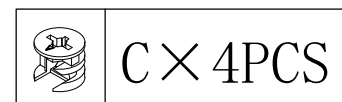
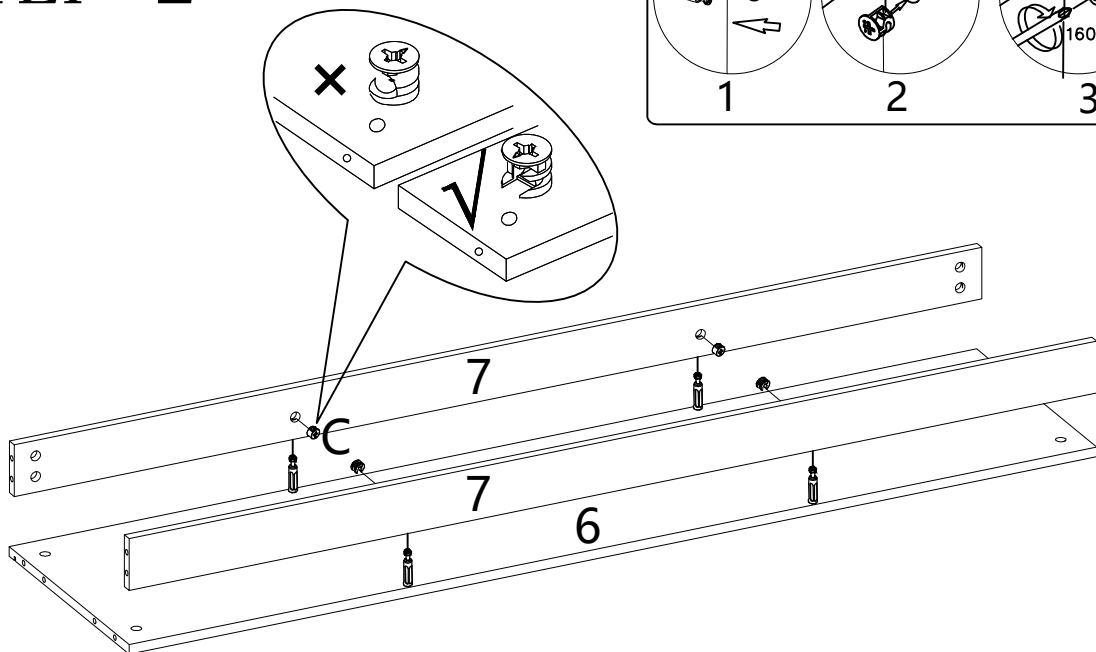
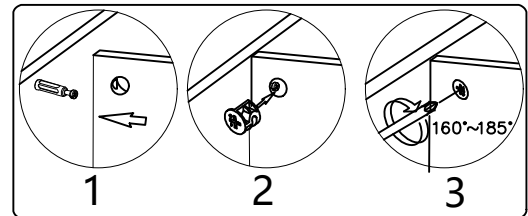

STEP 3

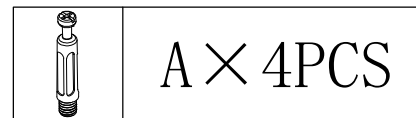
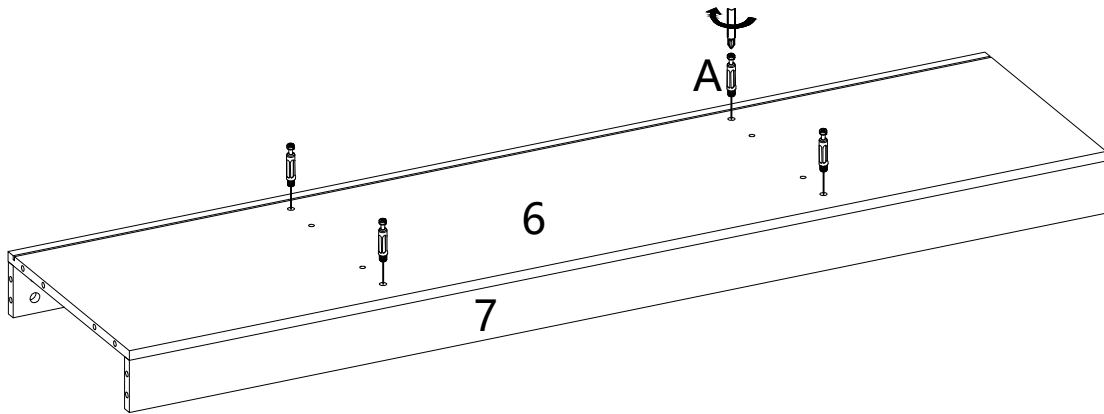
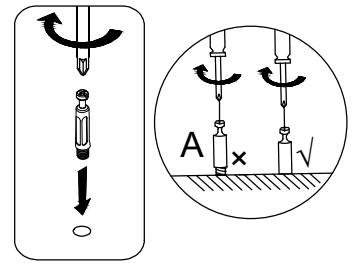

STEP 4

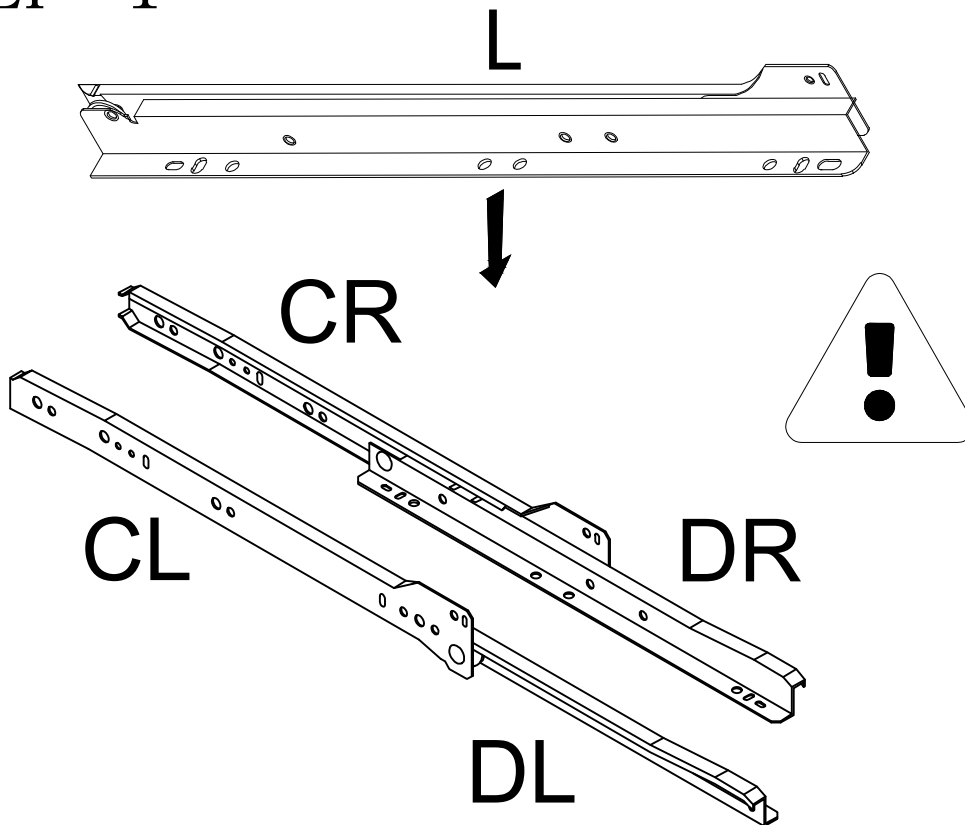

STEP 5

Lock the slides onto the plate according to the holes shown in the illustration.

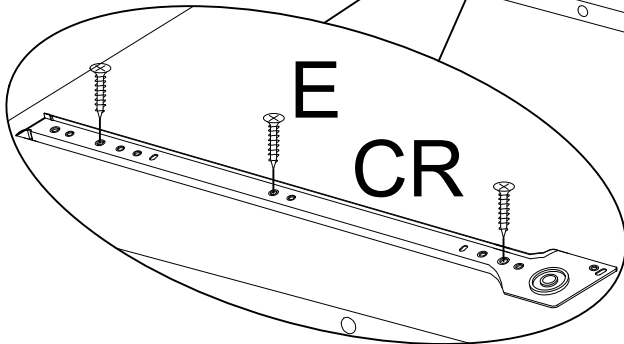
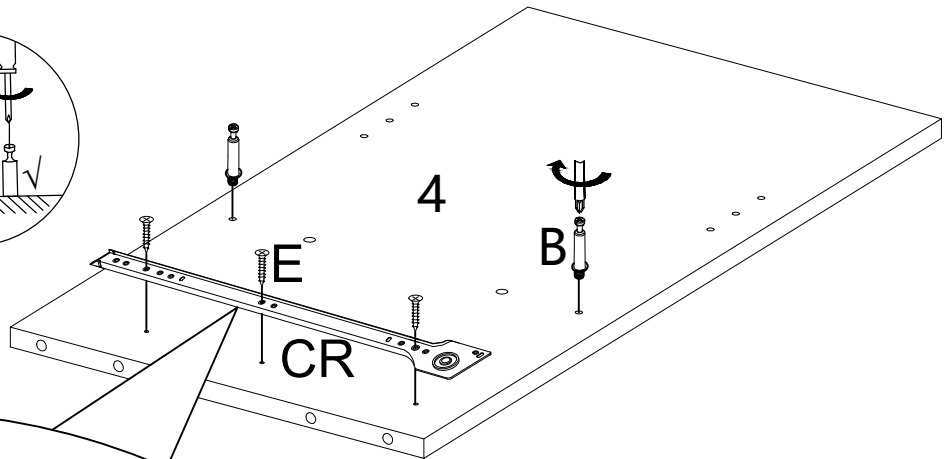
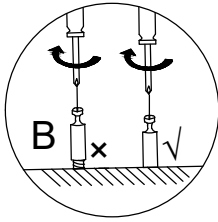
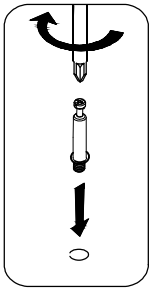

B × 2PCS

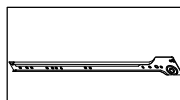

CR × 1PC



E × 3PCS

STEP 6

Lock the slides onto the plate according to the holes shown in the illustration.

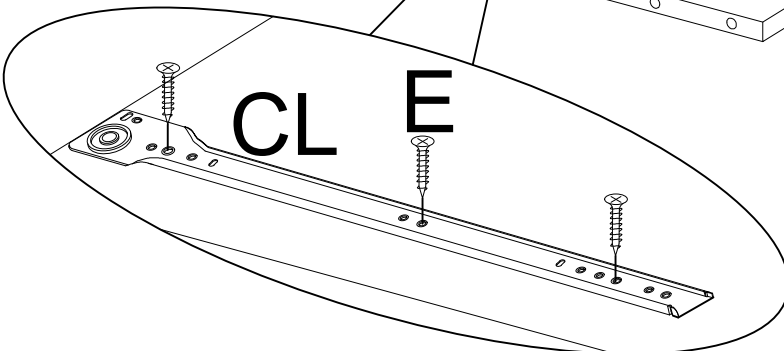
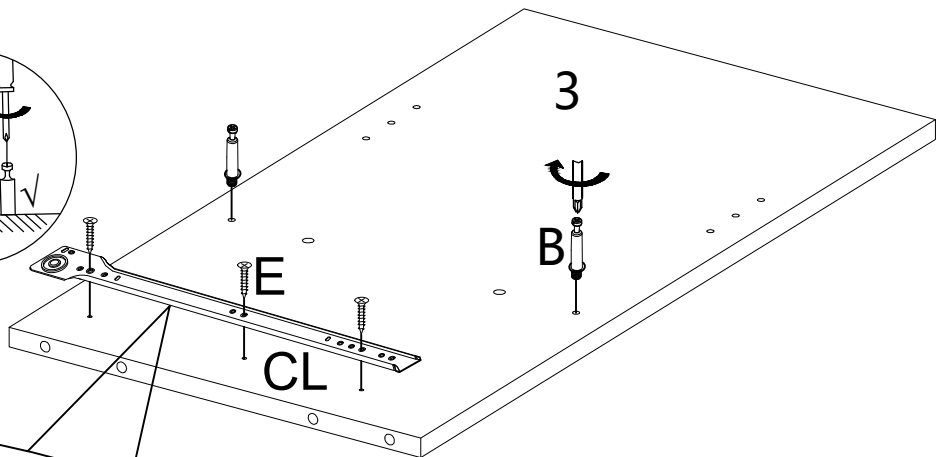
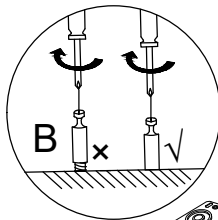
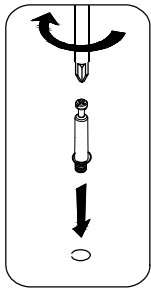

B × 2PCS

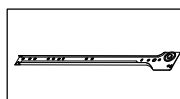



CL × 1PC

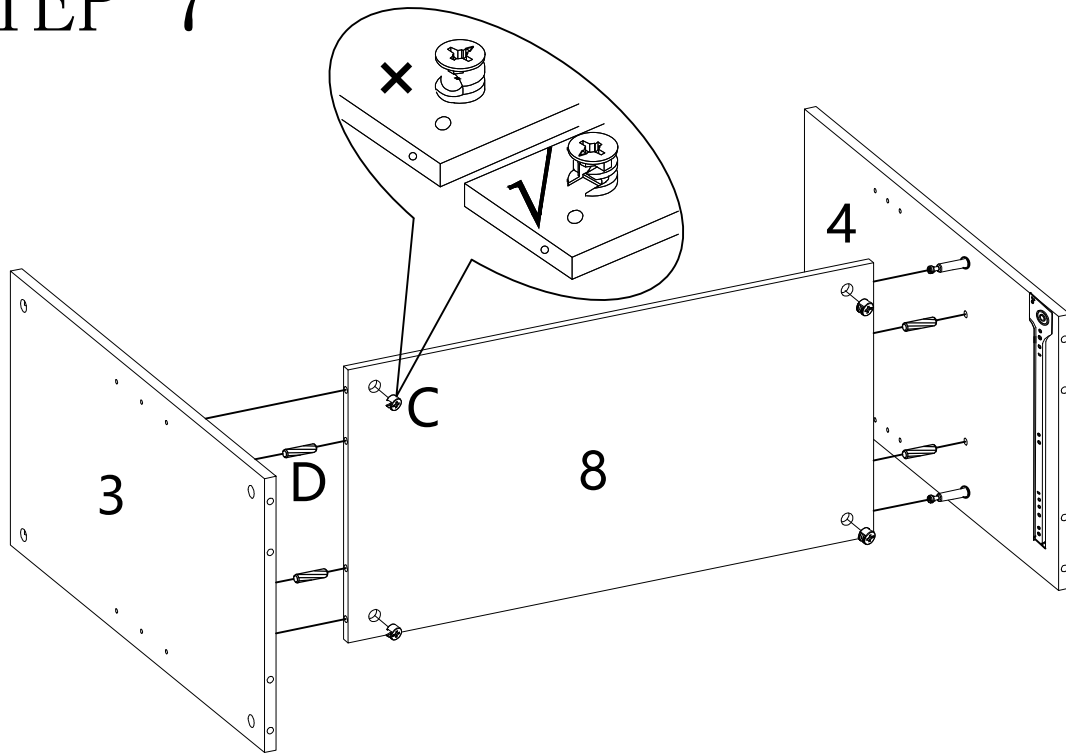

E × 3PCS

STEP 7



	D × 4PCS		C × 4PCS
---	----------	---	----------

STEP 8

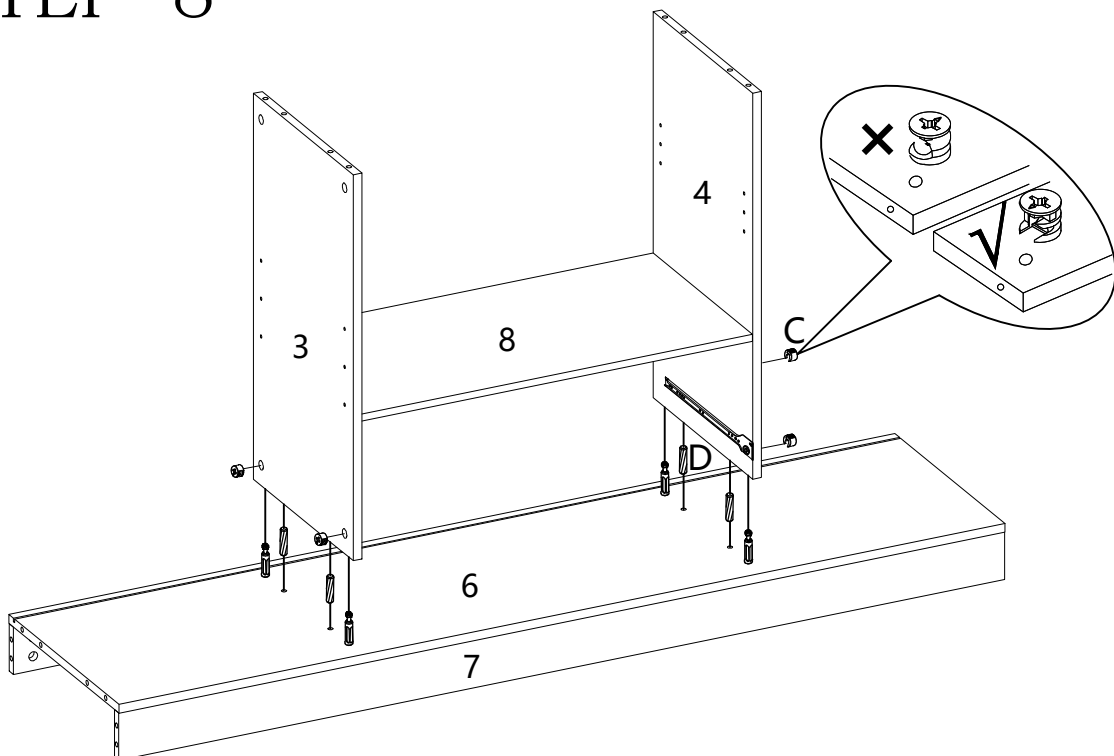

	D × 4PCS		C × 4PCS
---	----------	---	----------

STEP 9

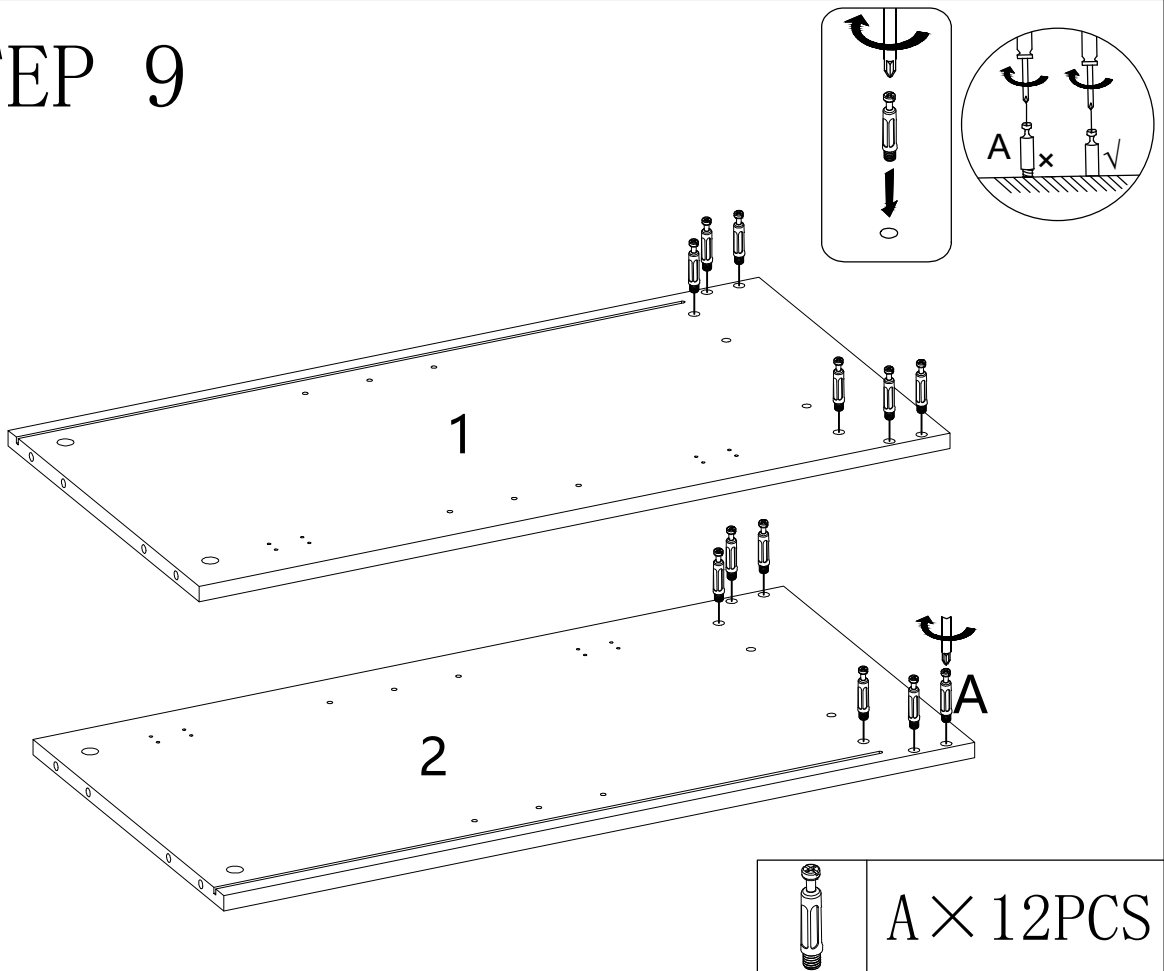

STEP 10

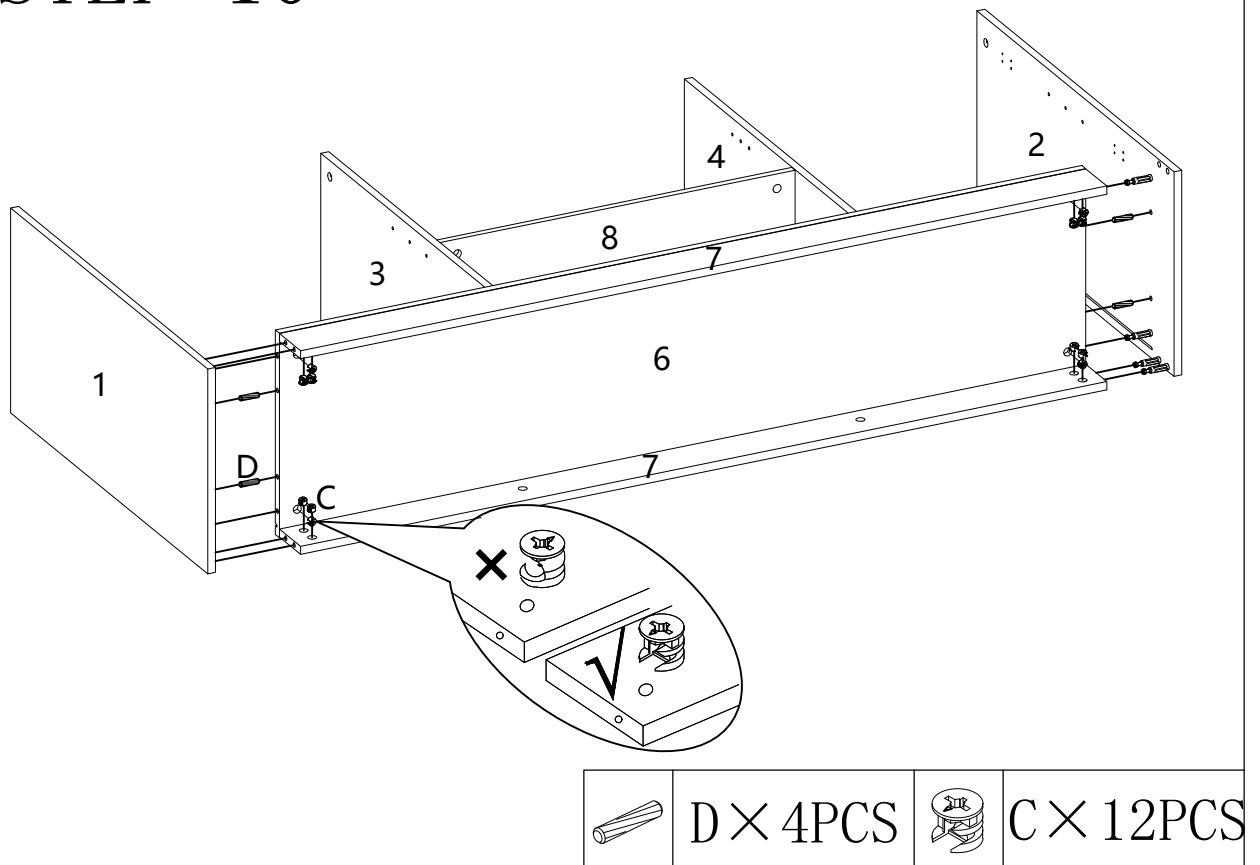

STEP 11

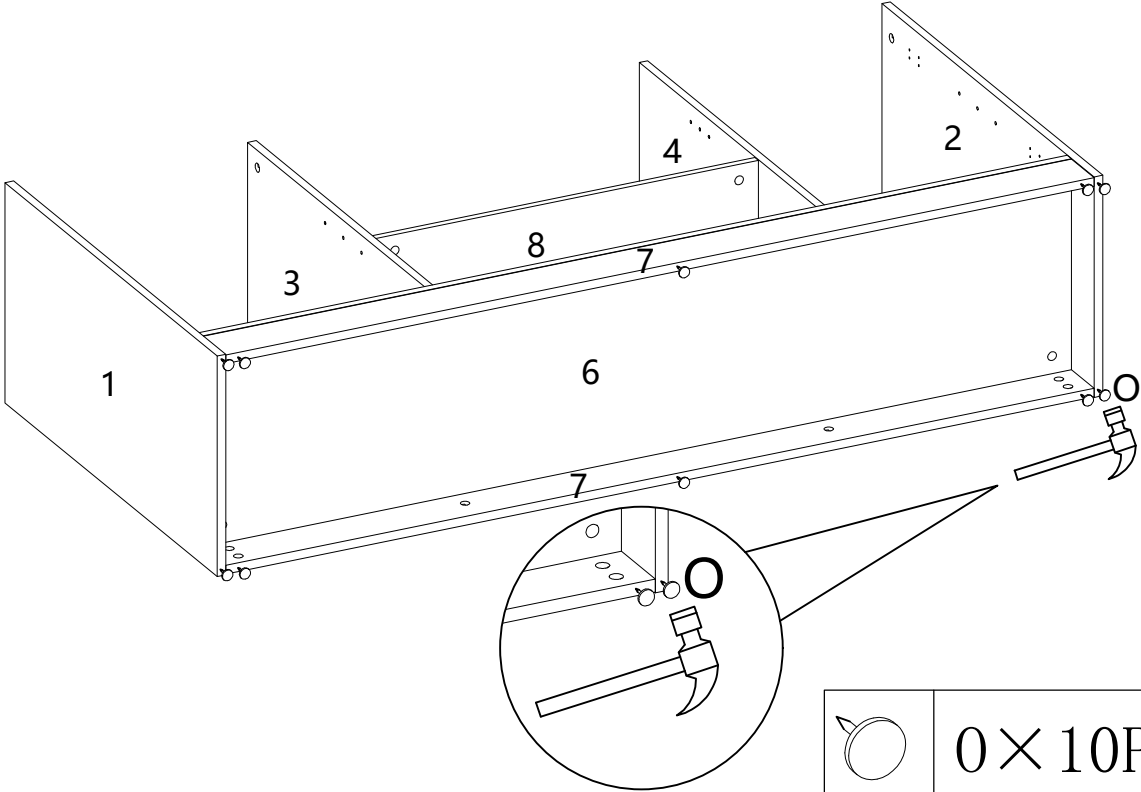



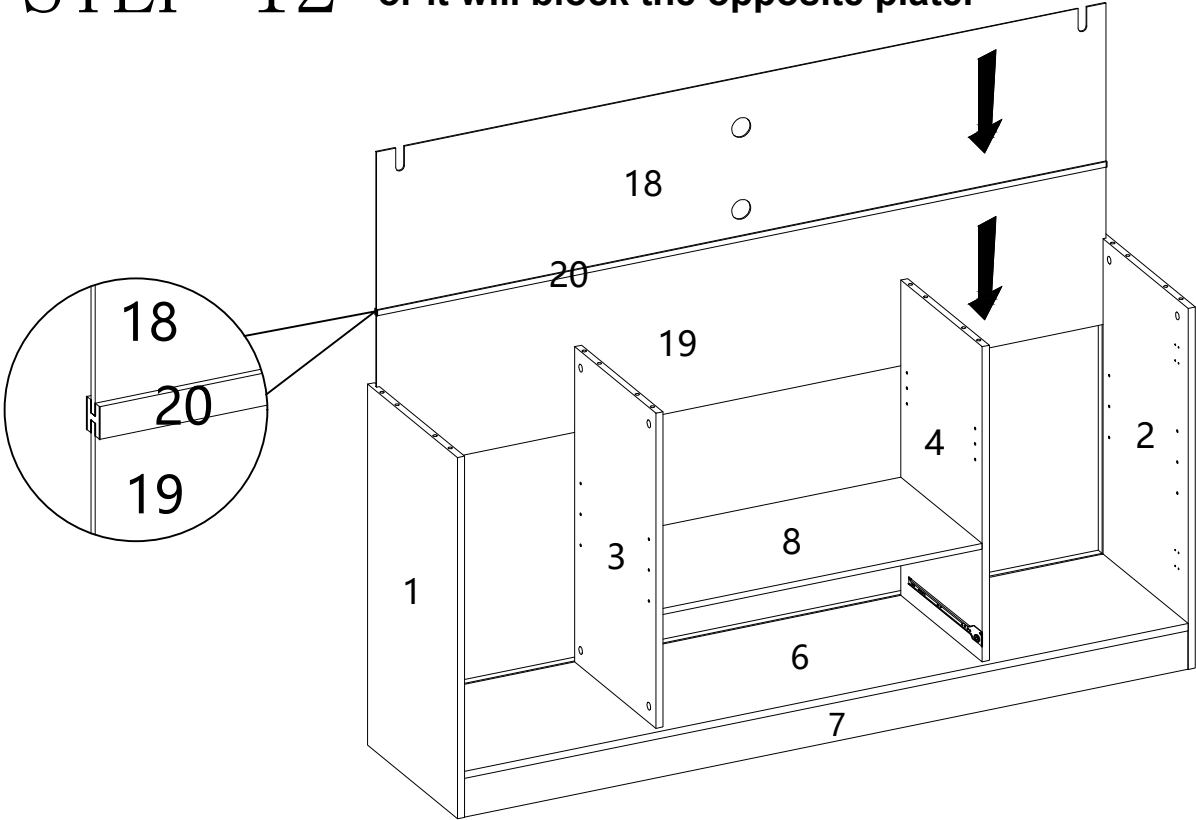

STEP 12

The thin backing plate must be located in the slot or it will block the opposite plate.

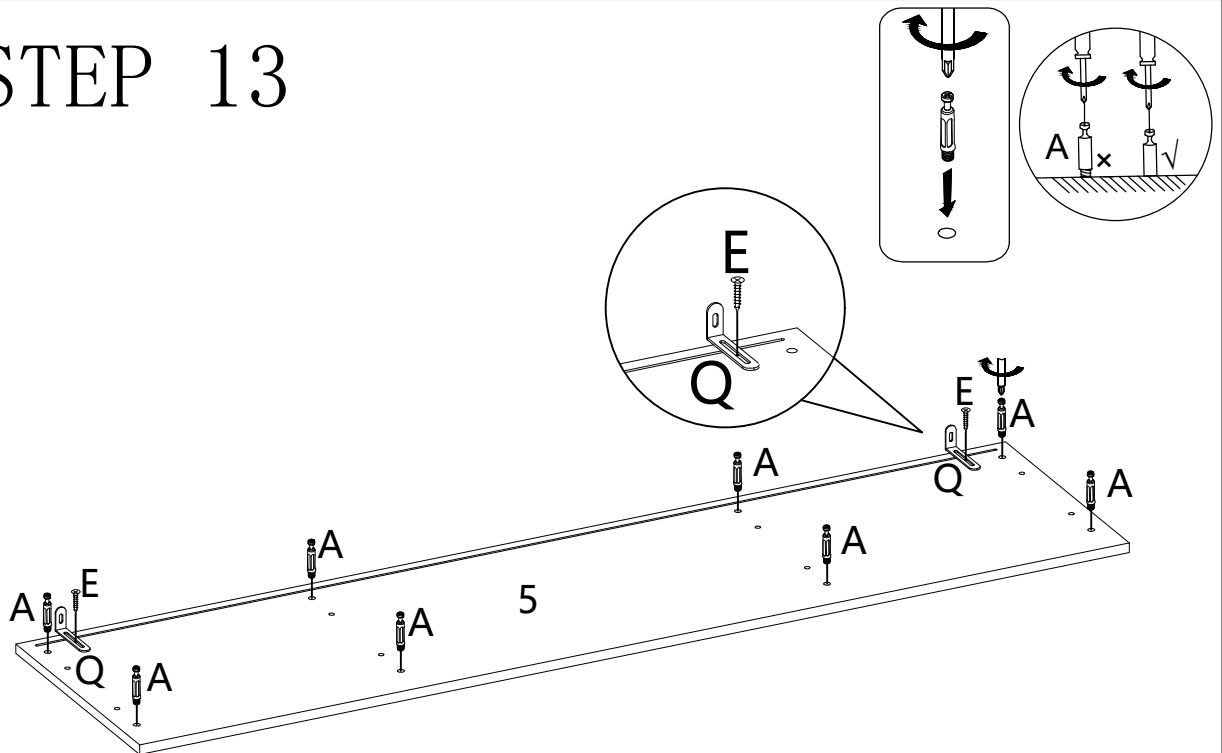



STEP 13



	A × 6PCS
	Q × 2PCS
	E × 2PCS

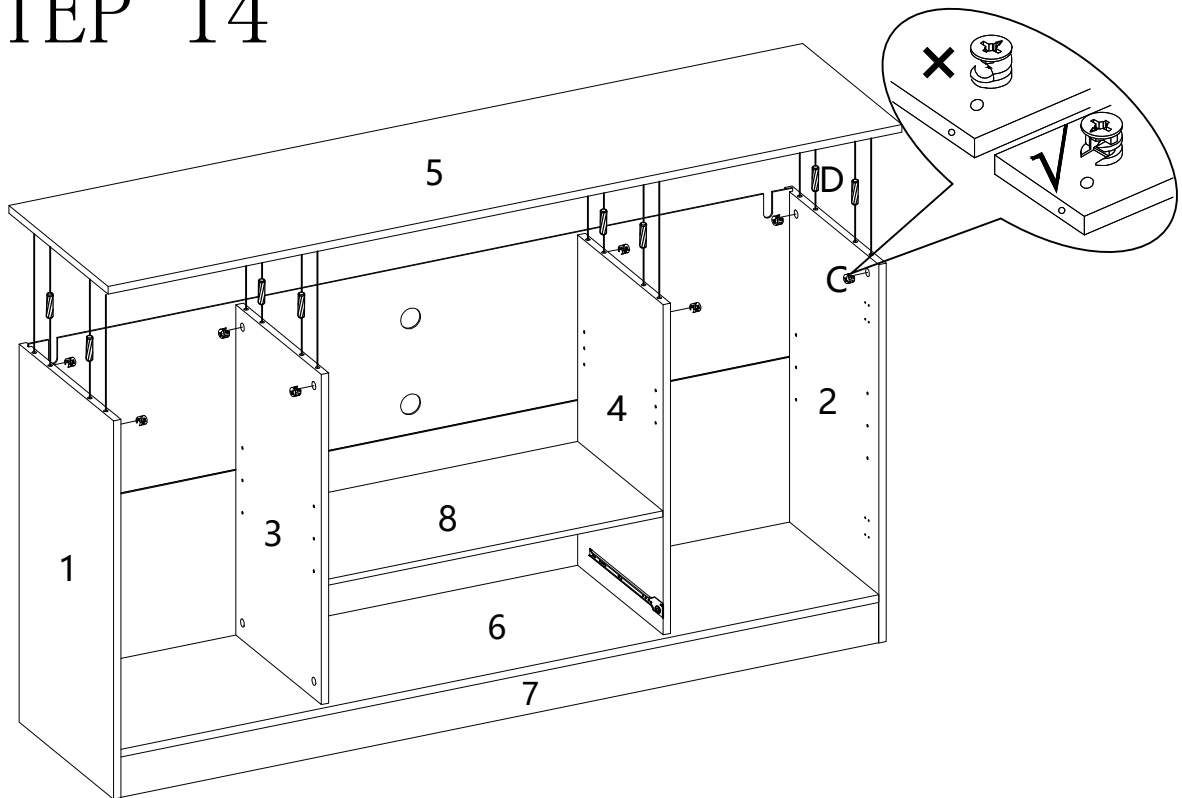

STEP 14

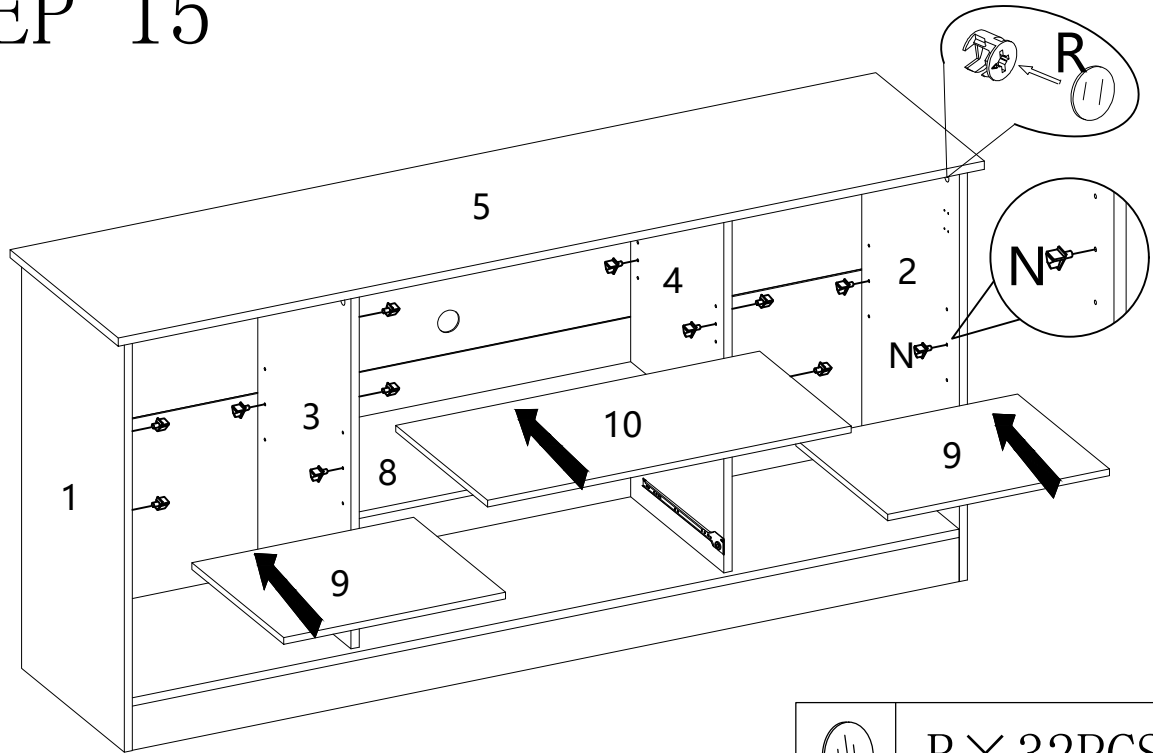

	D × 8PCS		C × 8PCS
---	----------	---	----------

STEP 15



	R × 32PCS
	N × 12PCS

Insert

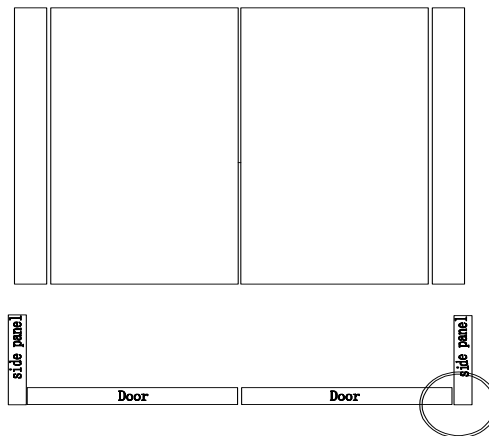

Doors was into the panel

M

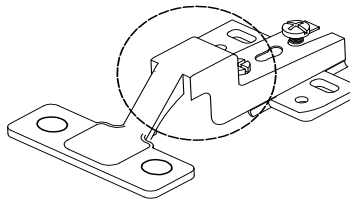



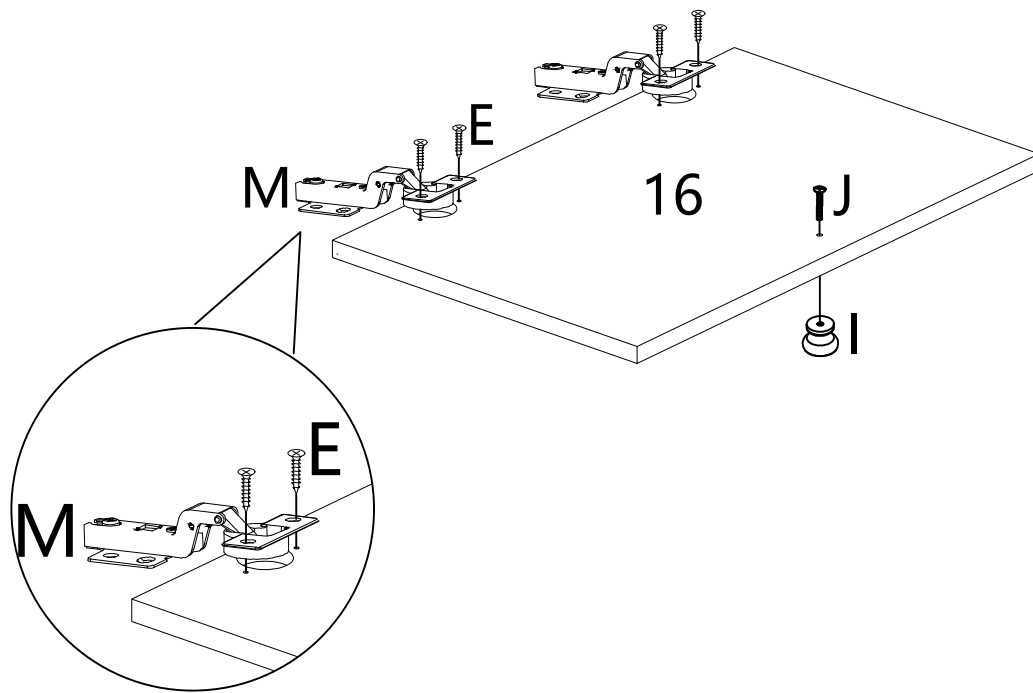

Insert
(For L/R Door)

STEP 16

×2



Inset Overlay

		E × 8PCS
		J × 2PCS
	M × 4PCS	 I × 2PCS

STEP 17

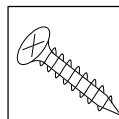
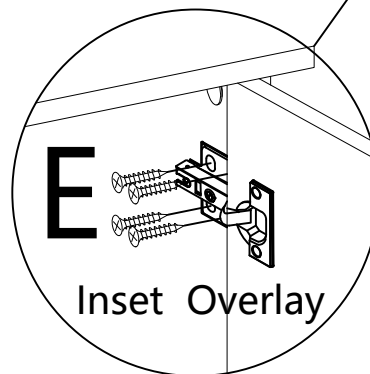
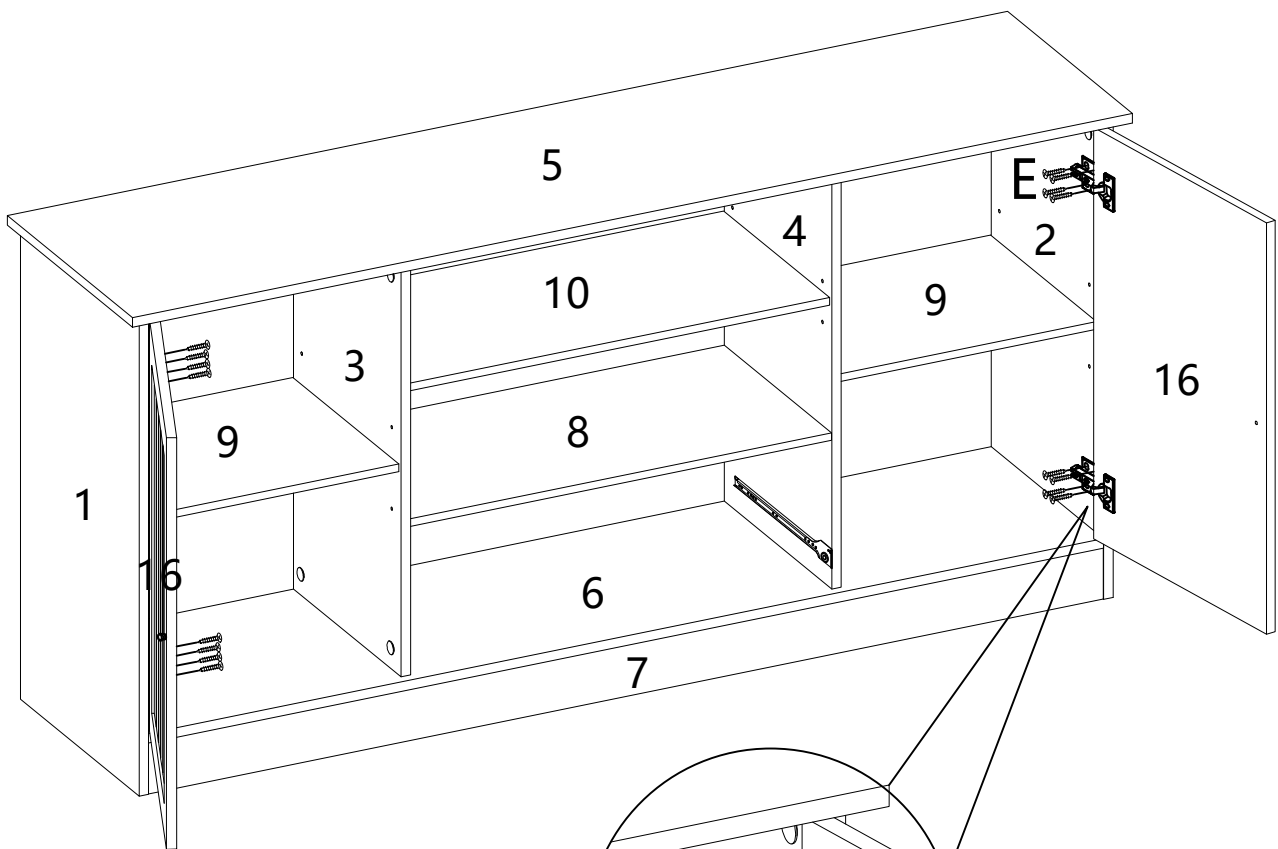

E × 16PCS

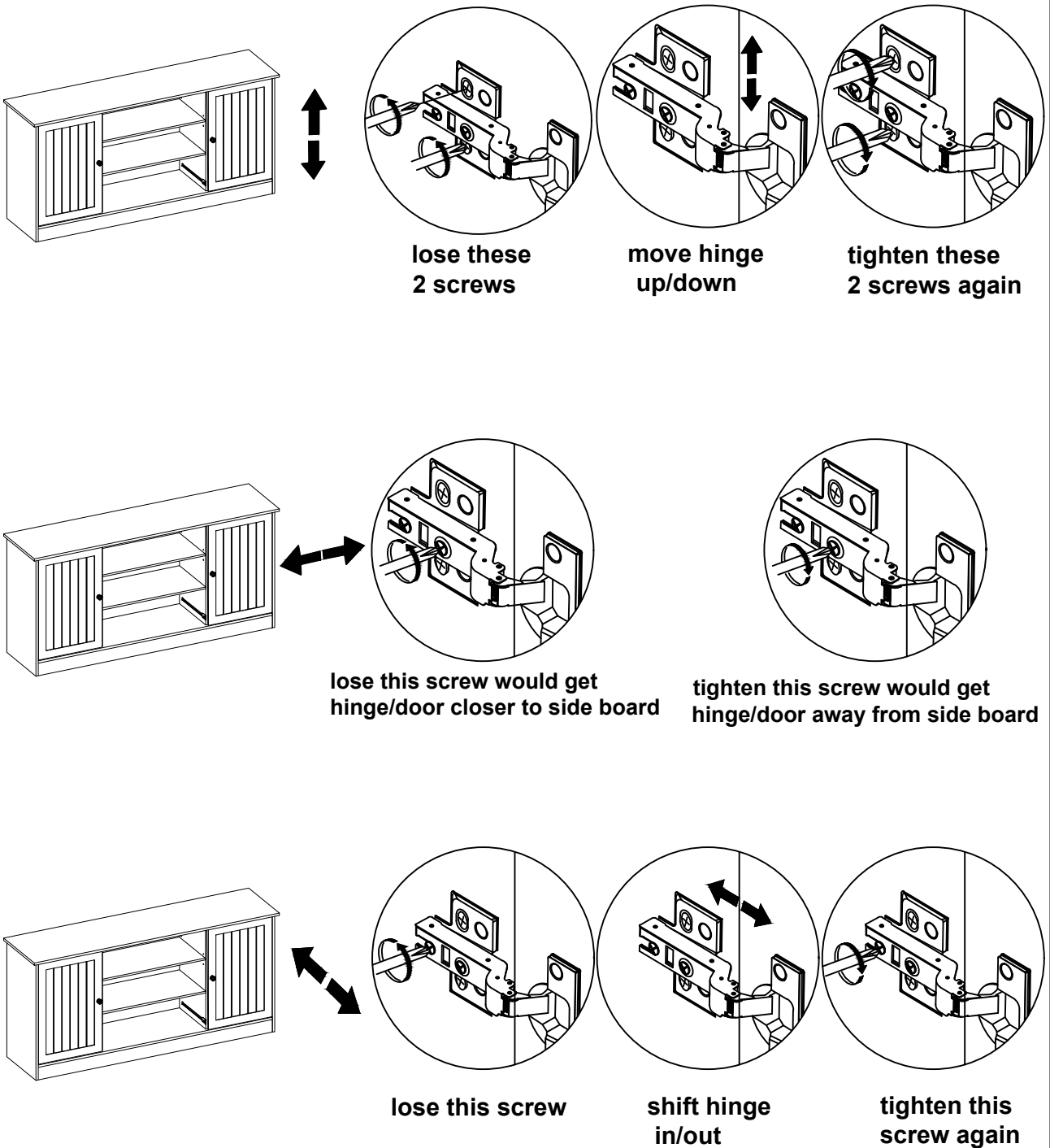

STEP 18

NOTE : If you notice that the cabinet doors are not properly aligned, such as significant gaps or vertical or horizontal misalignment, please adhere to the following adjustment instructions.

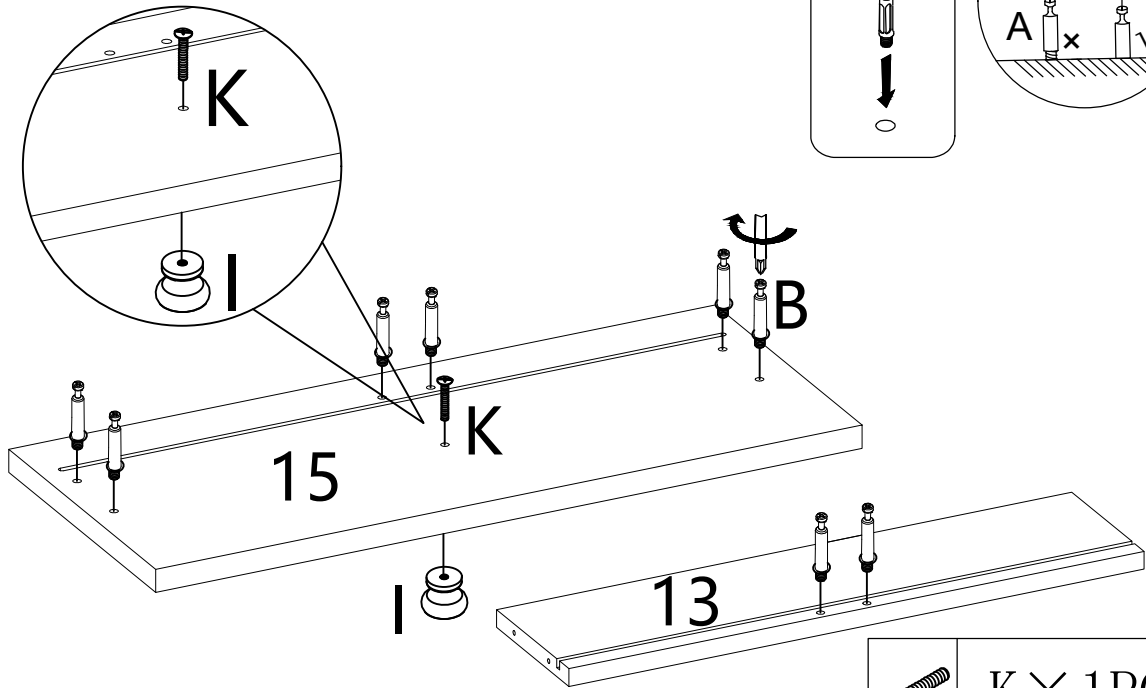

STEP 19



	K × 1PC
	B × 8PCS
	I × 1PC

STEP 20

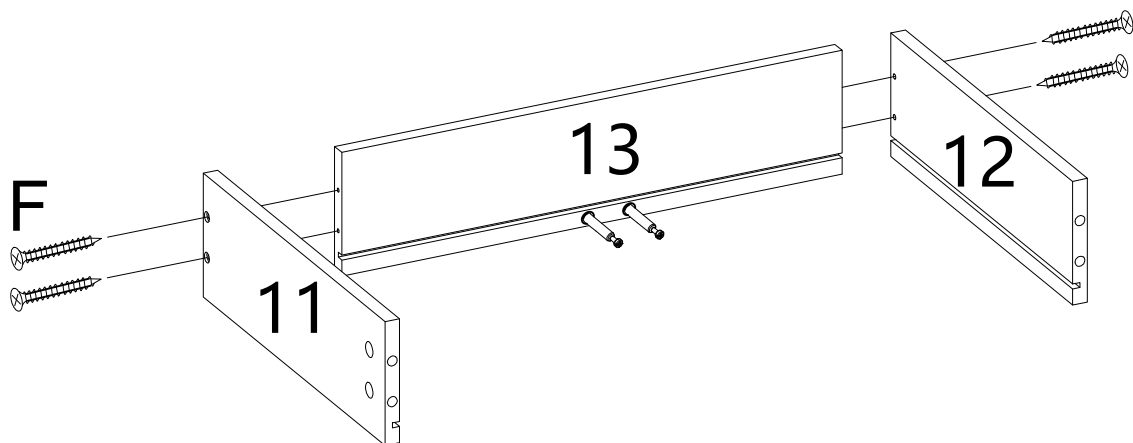

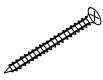
	F × 4PCS
---	----------

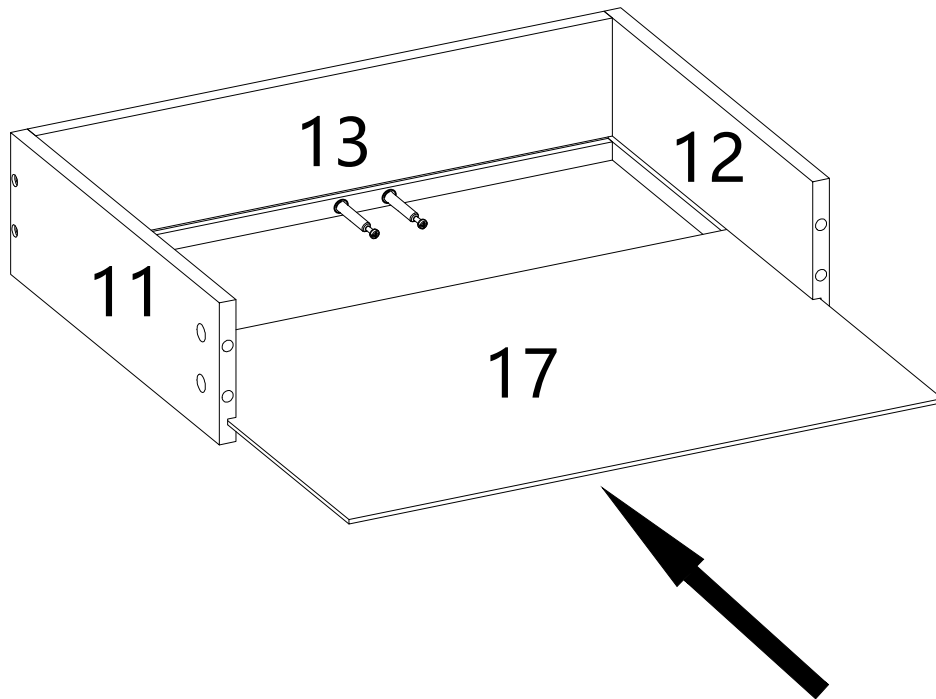

STEP 21

The thin backing plate must be located in the slot or it will block the opposite plate.

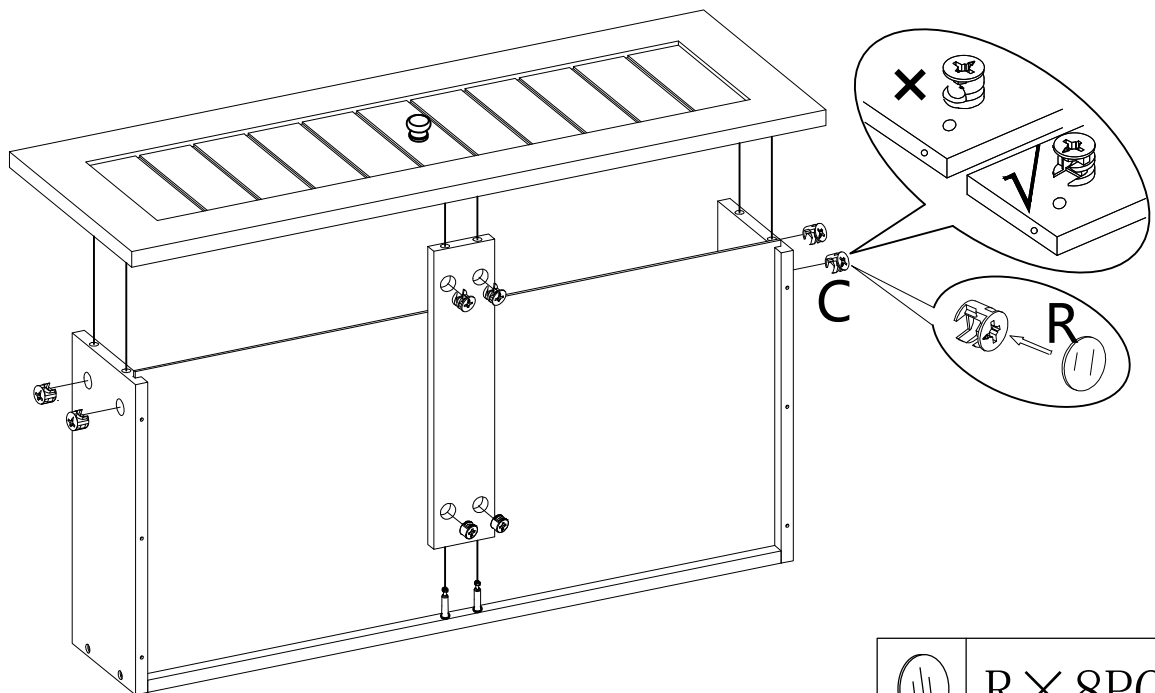

STEP 22



	R × 8PCS
	C × 8PCS

STEP 23

Lock the slides onto the plate according to the holes shown in the illustration.

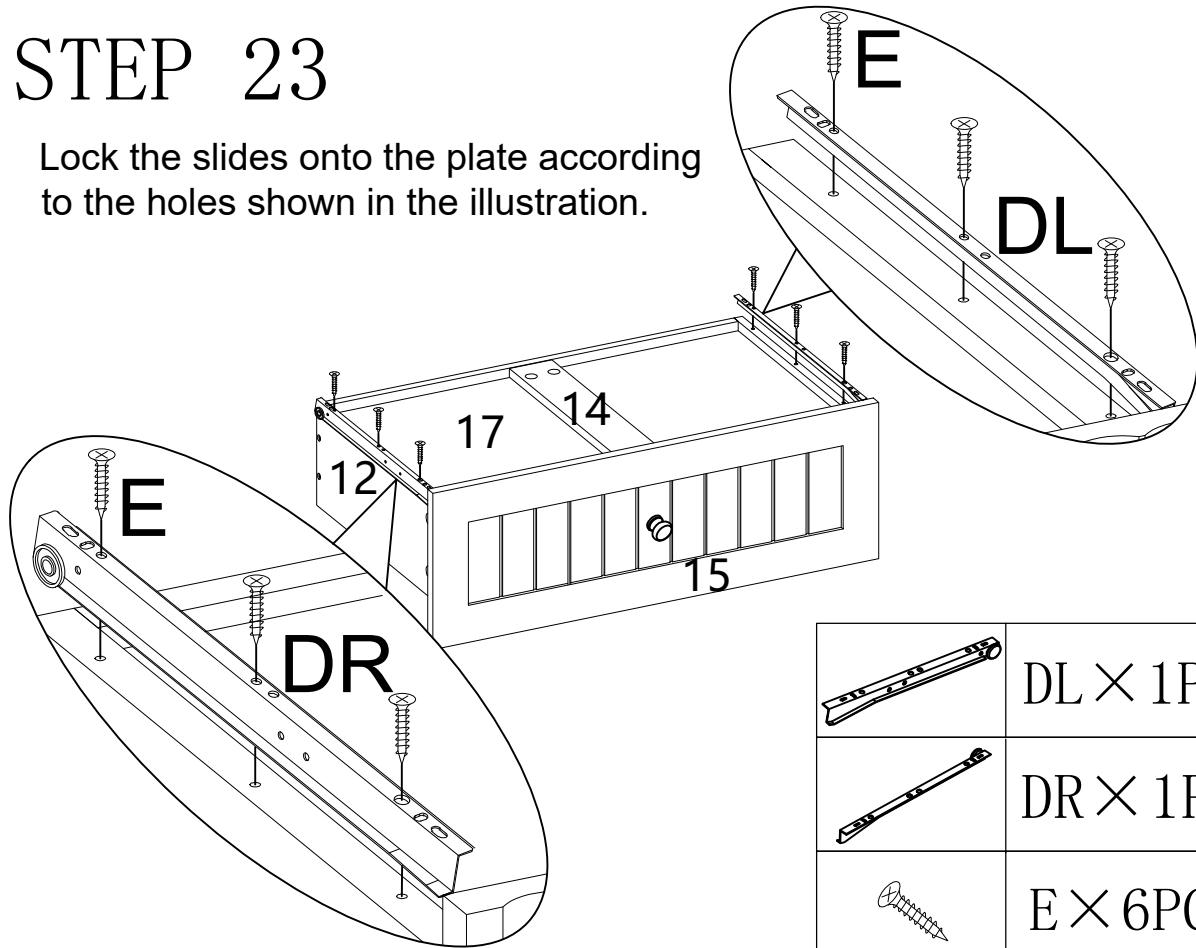

STEP 24

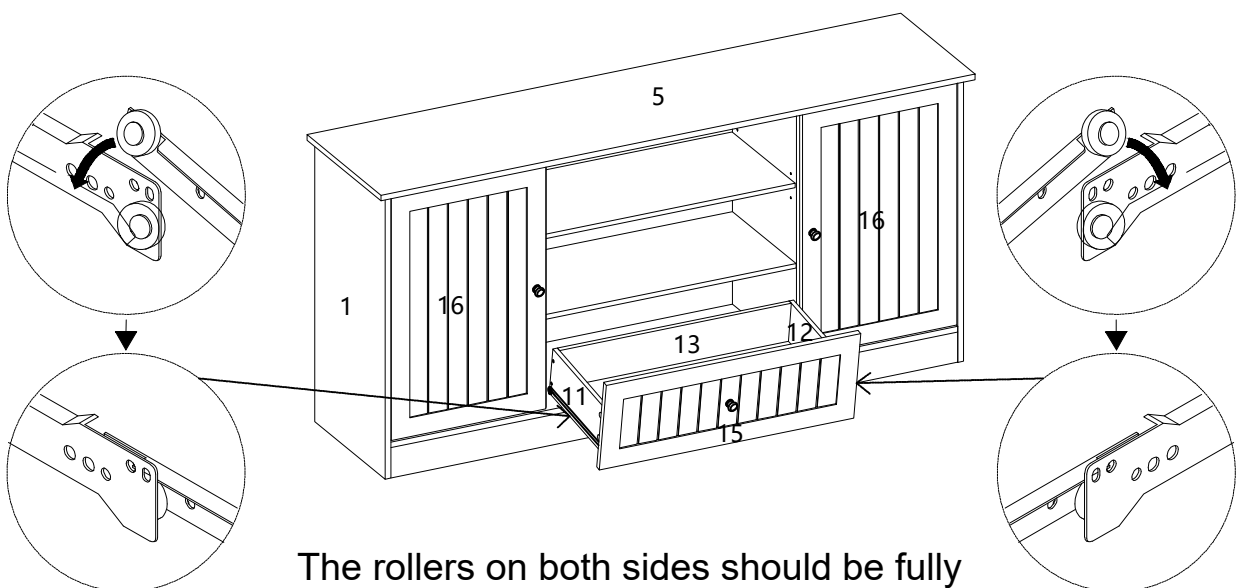

The rollers on both sides should be fully seated in the slides as shown.

STEP 27

Note: Toppling preventer must be installed other wise there is a risk of tipping.

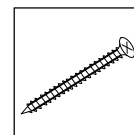
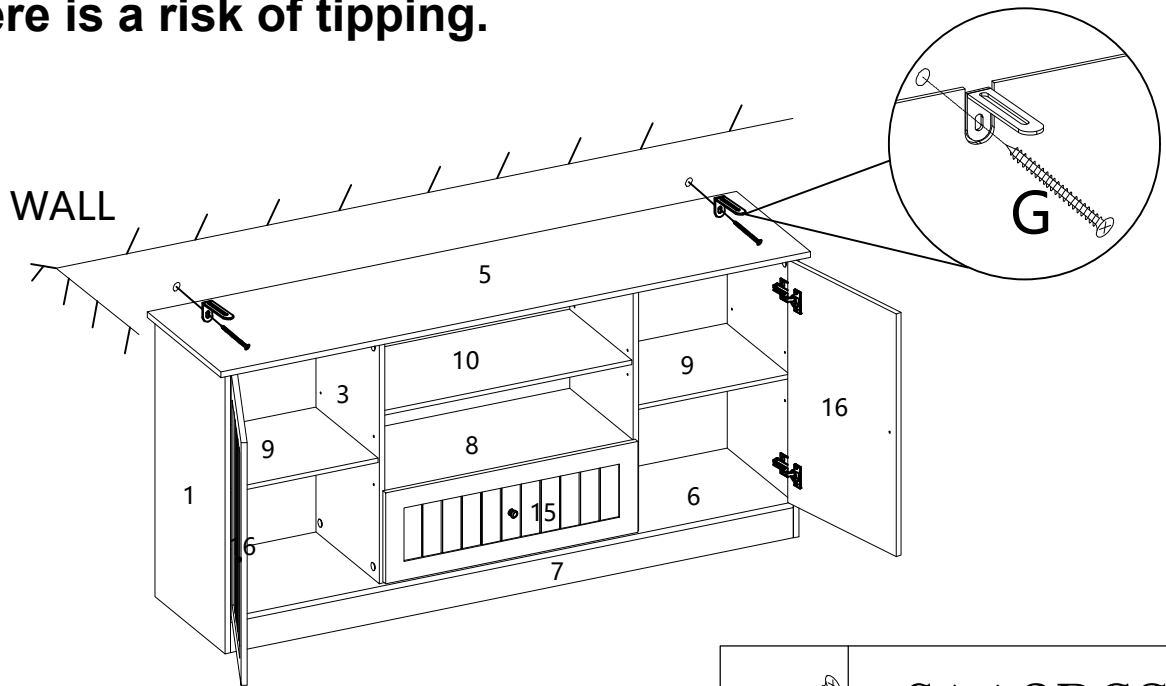

G × 2PCS

STEP 28

