

Assembly Instructions

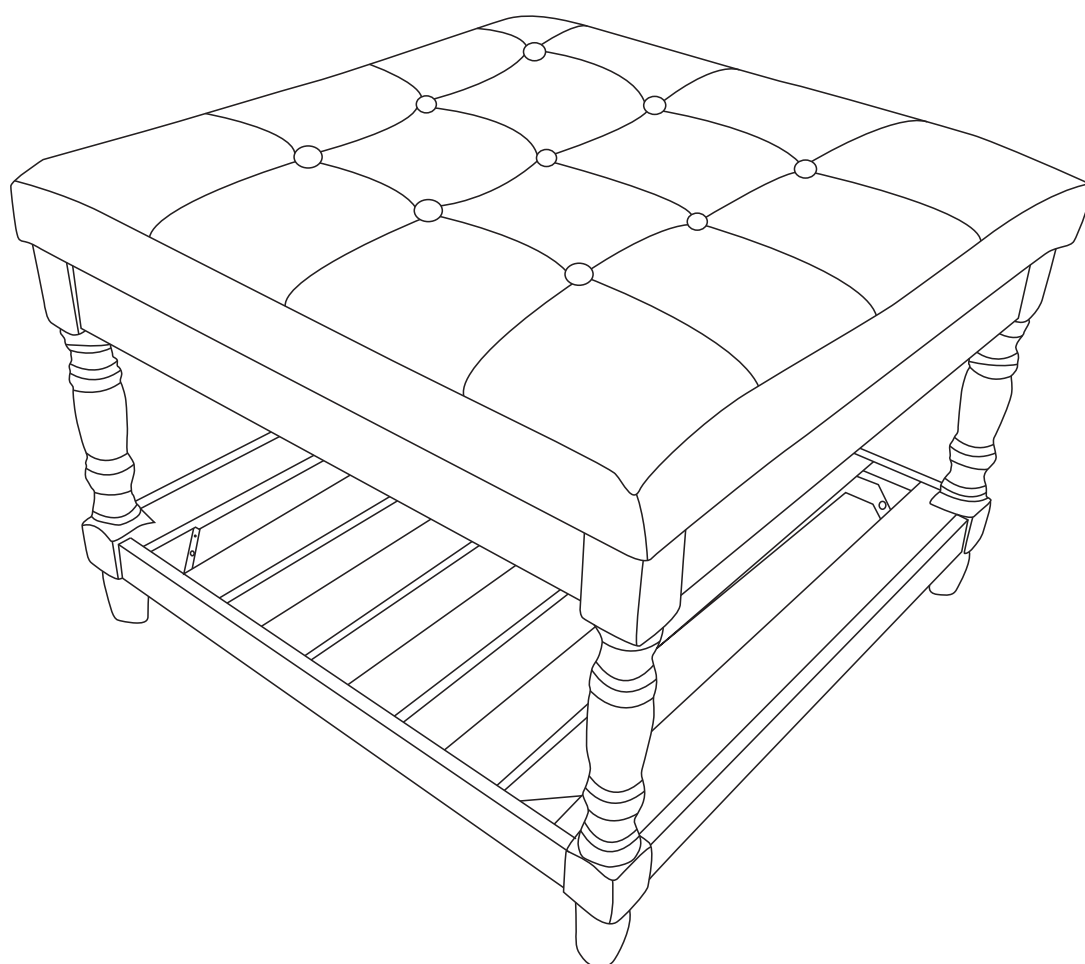

Assembly Instructions

ASSEMBLY REQUIREMENT

1 PERSON ASSEMBLY | 30 MINUTES ASSEMBLY TIME (APPROXIMATE)

TOOLS REQUIRED: ALLEN WRENCHES (PROVIDED)

ASSEMBLY REQUIREMENT

1. Remove all packaging materials, staples and packing straps from the carton.
2. Refer to Parts Checklist and ensure they are complete before you start assembling .

TIPS FOR ASSEMBLY

1. Allow ample room for assembly and in close proximity to where product will be placed.
2. Assemble the product on a surface that does not scratch or damage the exterior and finish of the furniture.
3. During assembly, do not over-tighten any fittings as this may cause damage.
4. **DO NOT USE POWER TOOLS TO ASSEMBLE THIS PRODUCT.**
5. Do not sit or stand on the partially assembled product, only use the product for which it is intended.

CARE AND USE

- Recommended for indoor and residential use only.
- Wipe with a soft, dry cloth. DO not use harsh abrasives or household cleaners as they may damage the finish.
- Check all the fittings periodically and re-tighten as necessary. Do not use the product if any of the parts is damaged or broken.

Accent Chairs Limited Warranty

Accent chairs are warranted from the date of purchase against failure due to material and workmanship as follows

1 YEAR on component parts including screws, pillow and armrests.





1 YEAR on Upholstery fabric and foam against wear and deterioration.

To make a warranty claim, please contact us, provide model number, proof of purchase description of the problem.

At it's option We will:

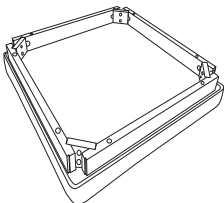
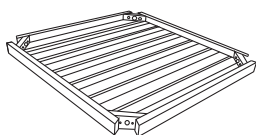
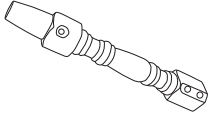
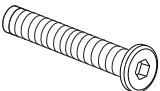
- a) Supply compatible components of current manufacture.
- b) Send a new product if necessary, customer must return the original product to the warehouse. Return freight will be paid by us.

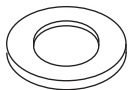
PARTS CHECKLIST

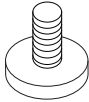
 <p>Ax1</p>	 <p>Bx1</p>	 <p>Cx4</p>	<p>M8*60</p>  <p>Dx12</p>
<p>M8</p>  <p>Ex12</p>	<p>8*22*1.5</p>  <p>Fx12</p>	 <p>Gx1</p>	 <p>Hx4</p>

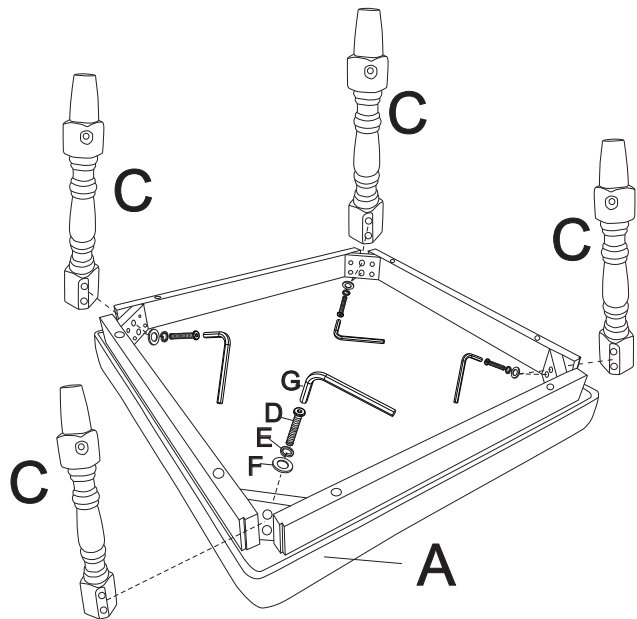

AX 1
CX 4
DX 8
EX 8
FX 8
GX 1

Step 1: Check that the fittings are complete before installation. Use part D (screw), part E (ring), part F (Gasket), connect part C (leg) to part A (Top) and tighten with part G.

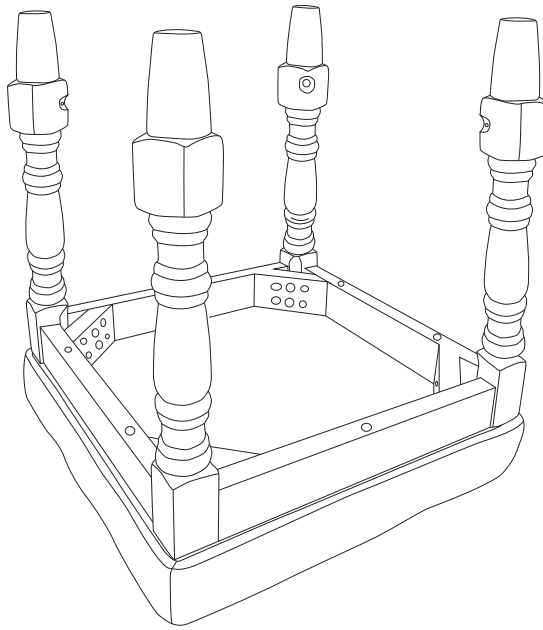

Step 2: Step 1 After the installation is complete

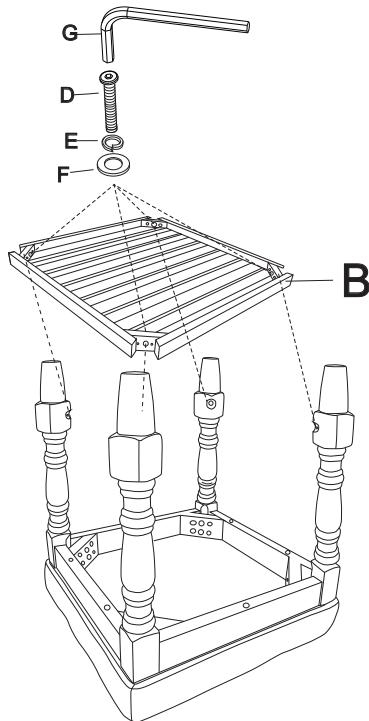

B X 1

D X 4

E X 4

F X 4

G X 1

Step 3: Install as instructed on the label,
 Use Part D (screw), Part E (ring),
 Part F(Gasket), connect Part B(bottoms)
 to Part C(leg), and tighten with Part G.

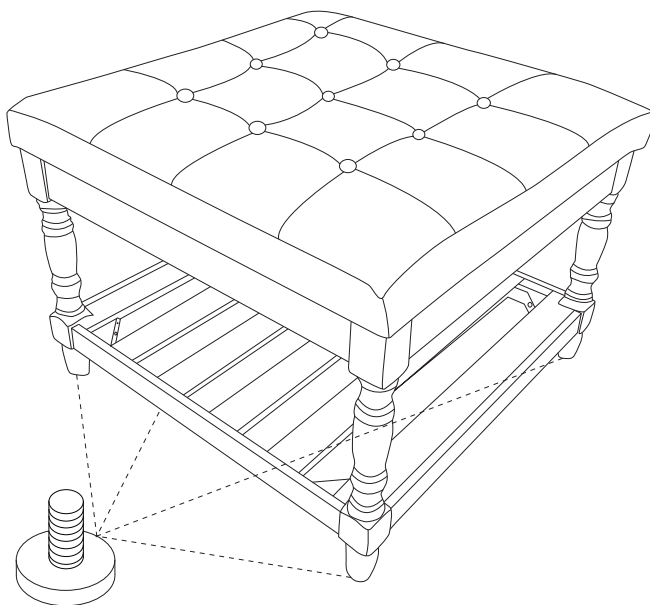

Step 4: Finally, install Part H(footpad) on Part C(leg)

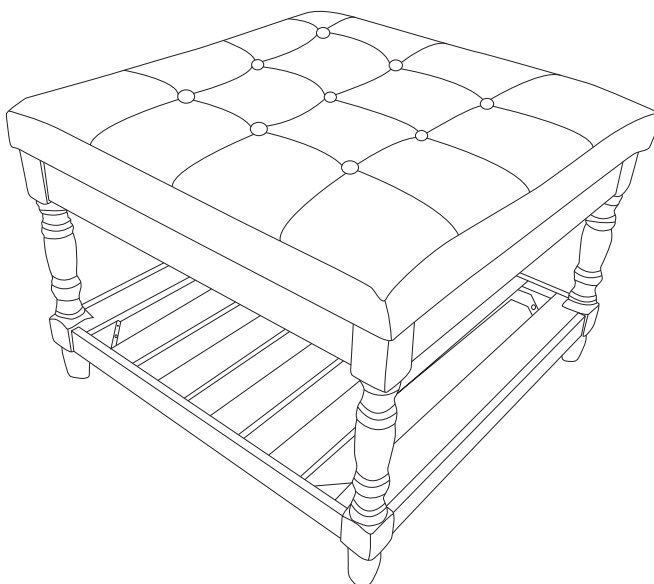

Step 5: After installation, the height can be raised or lowered by adjusting part H(footpad).