

Installation & Assembly

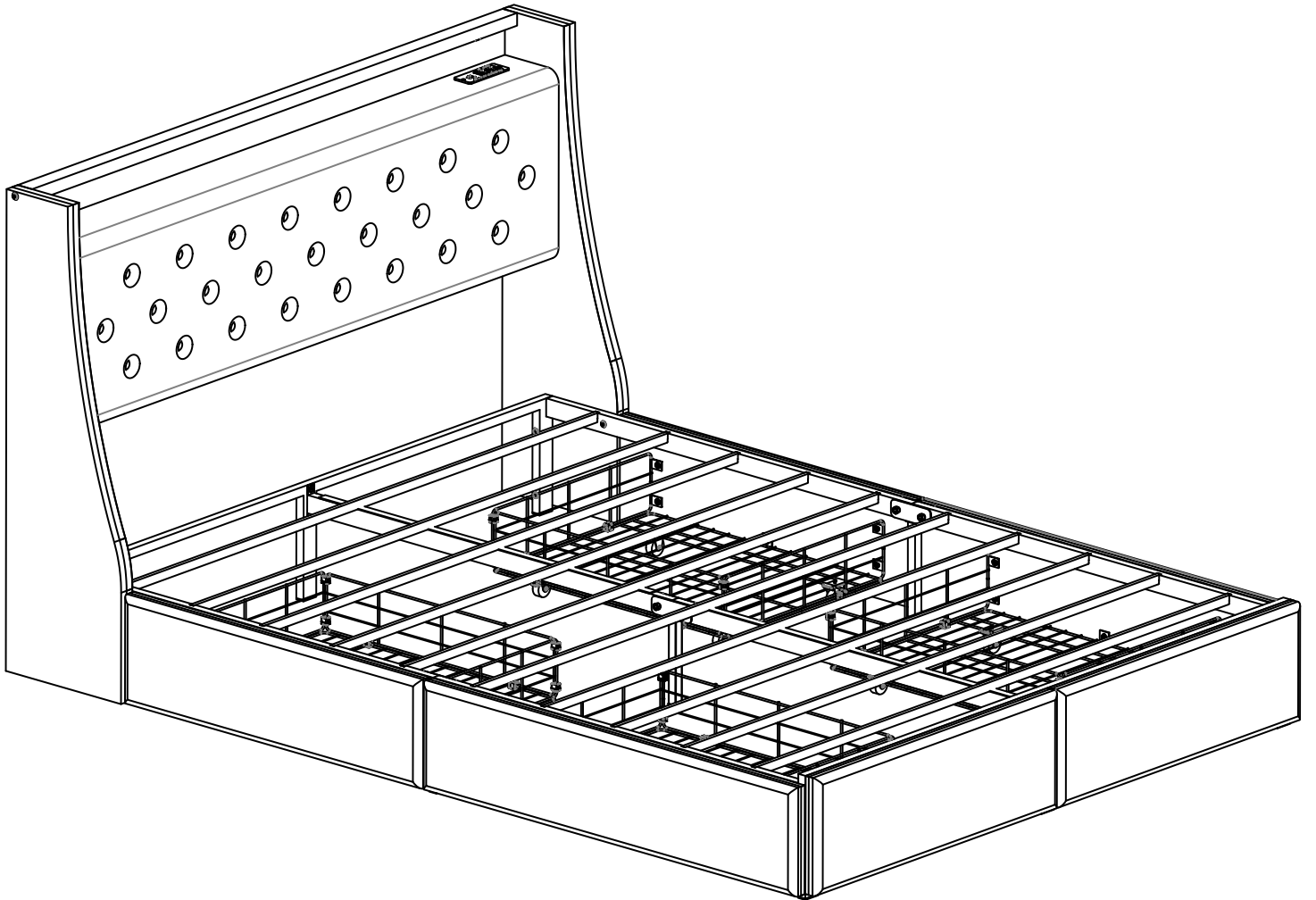

Parts List:

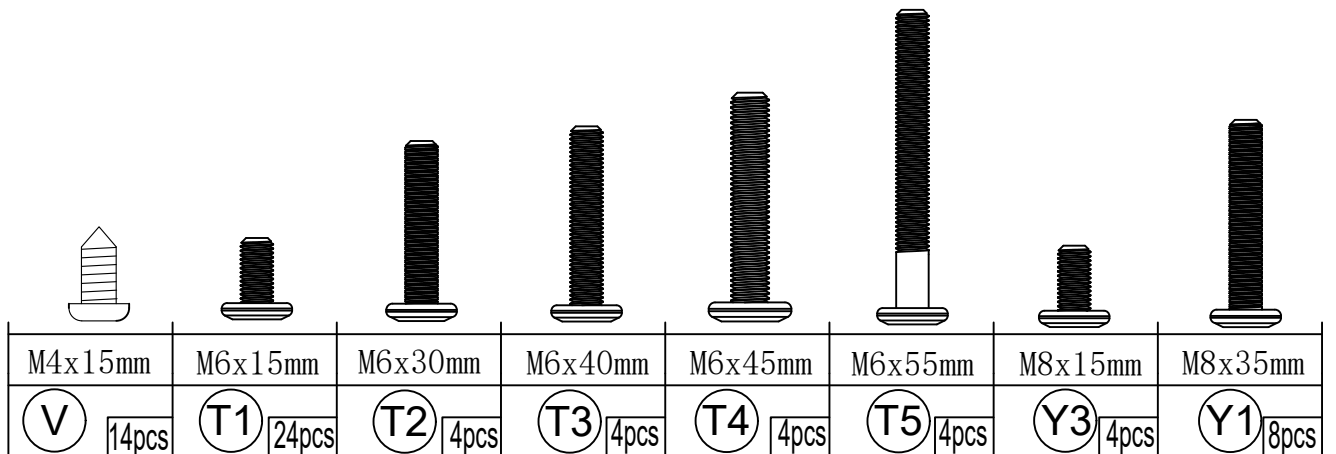
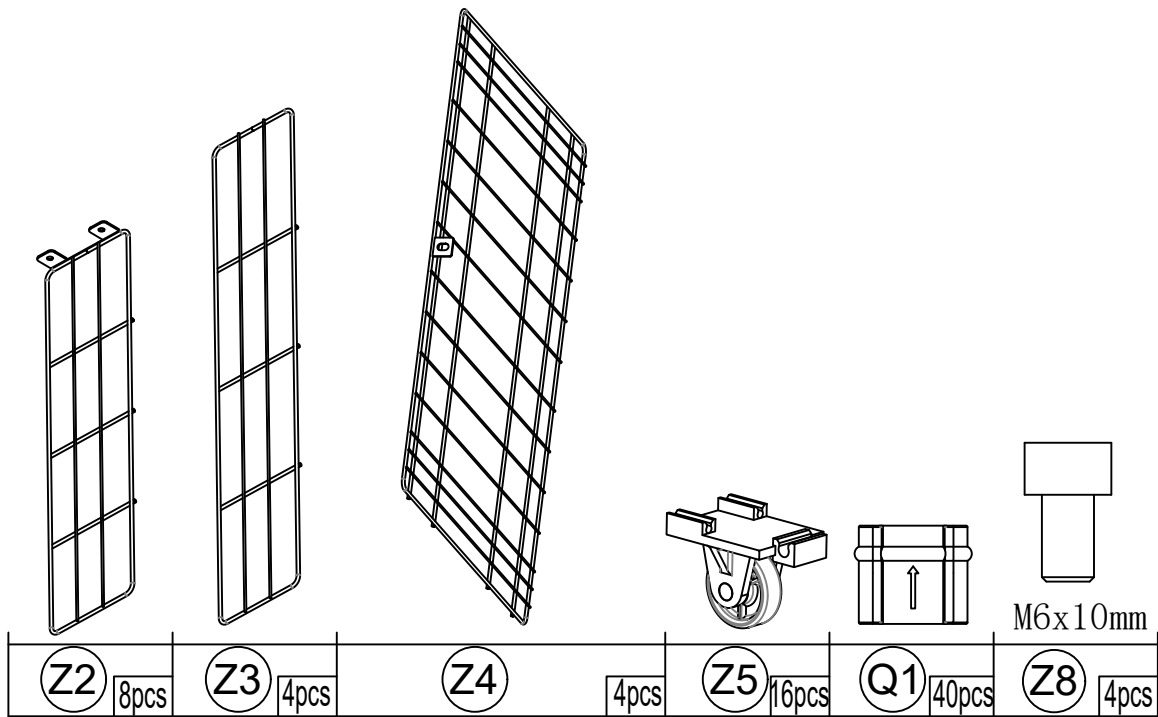
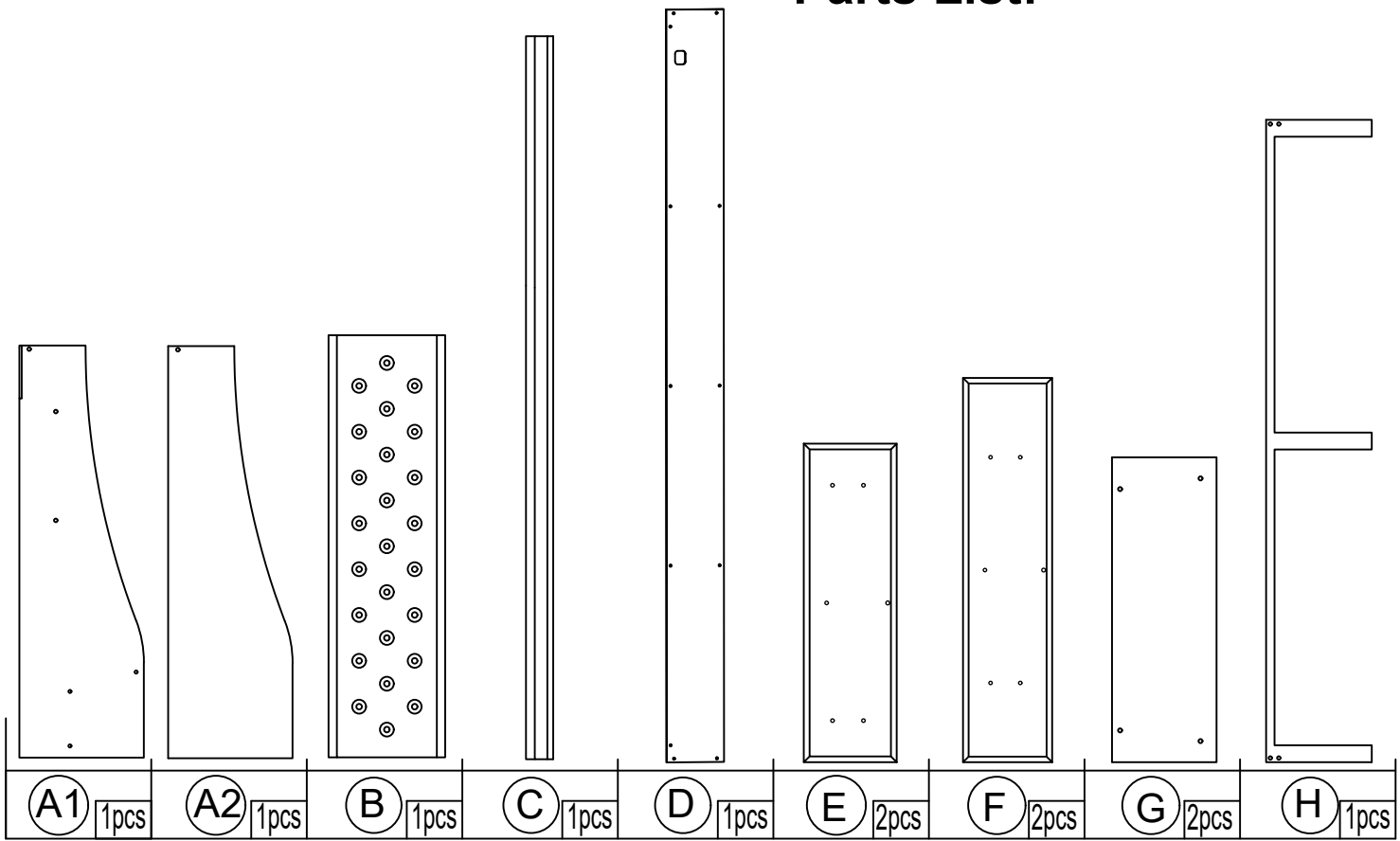

Parts List:

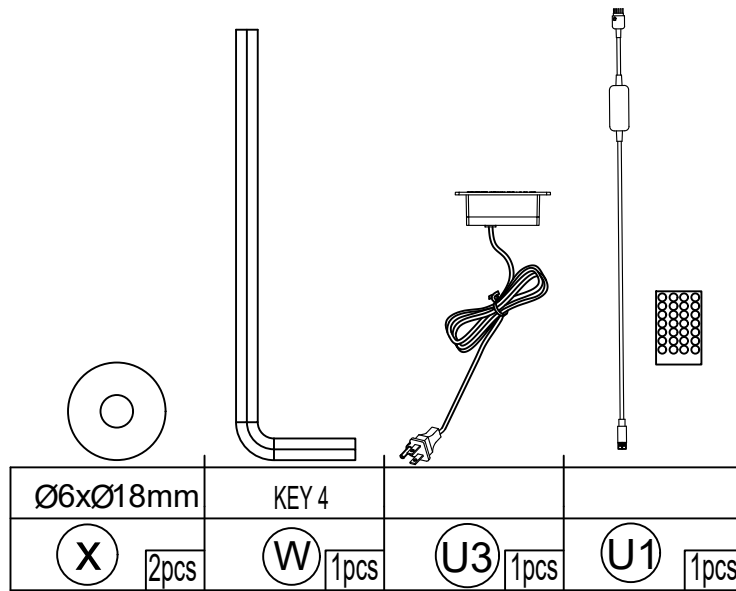
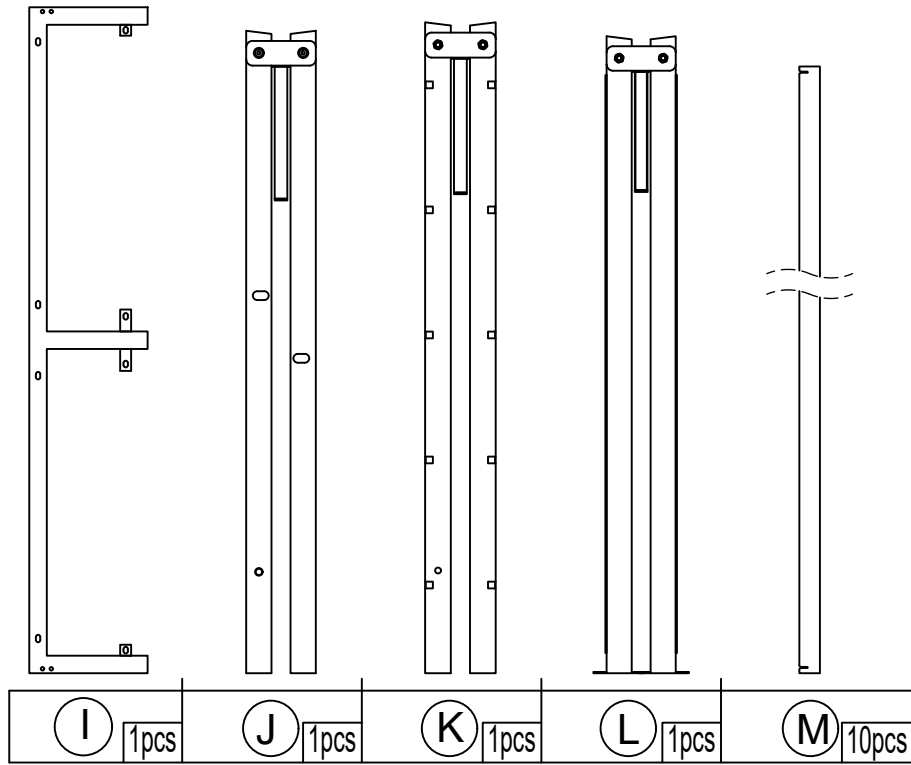

Step 1

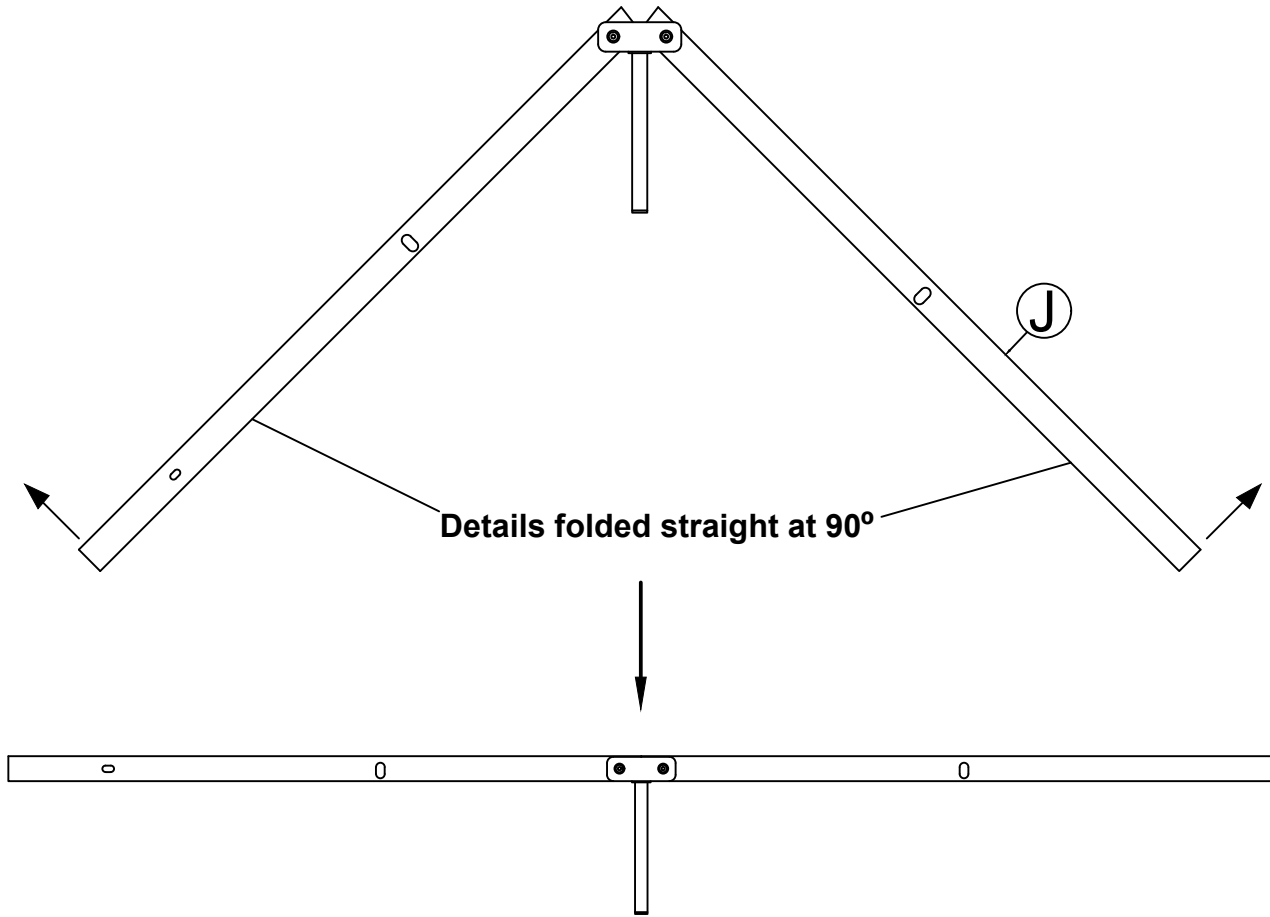

Step 2

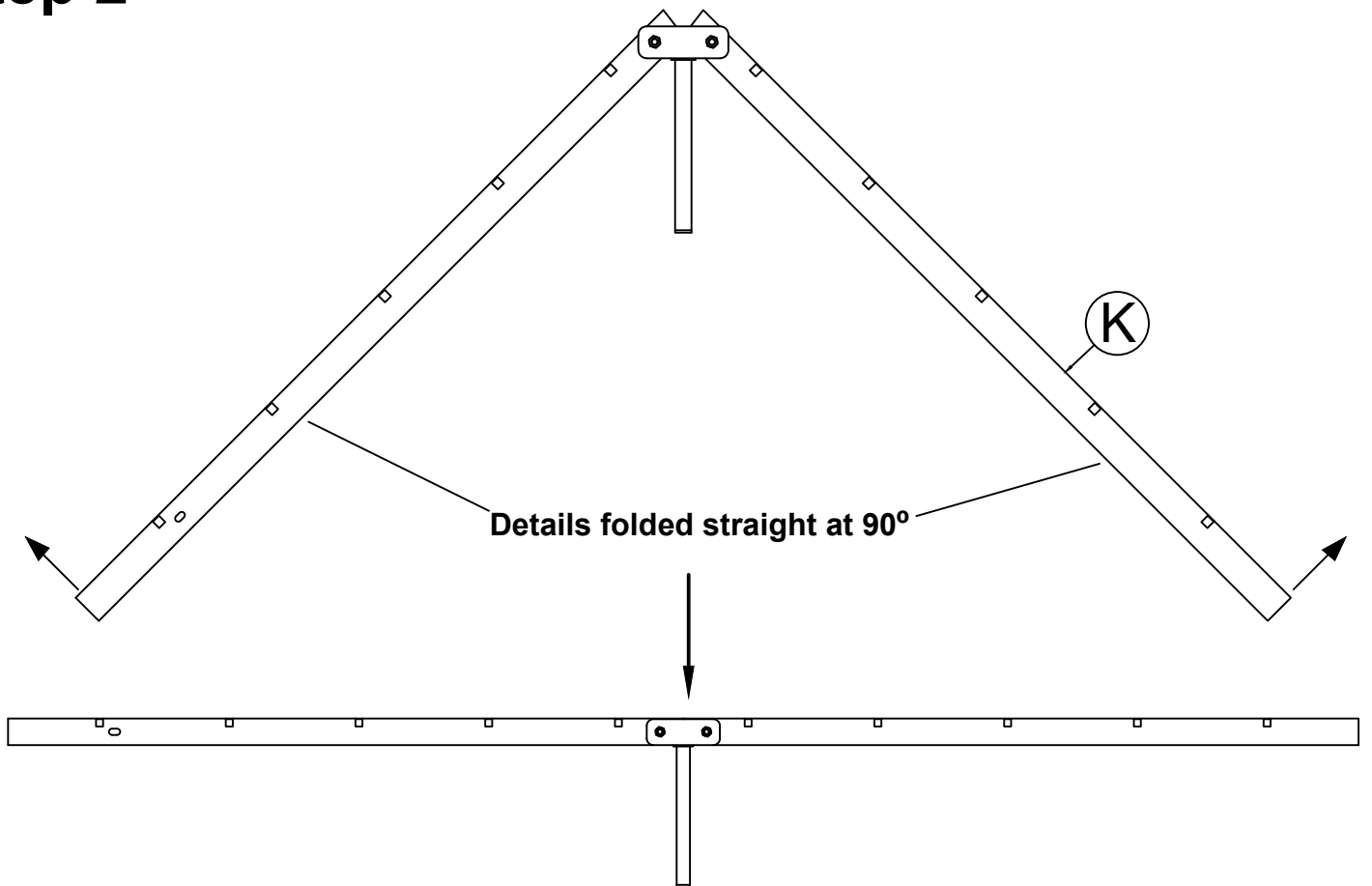

Step 3

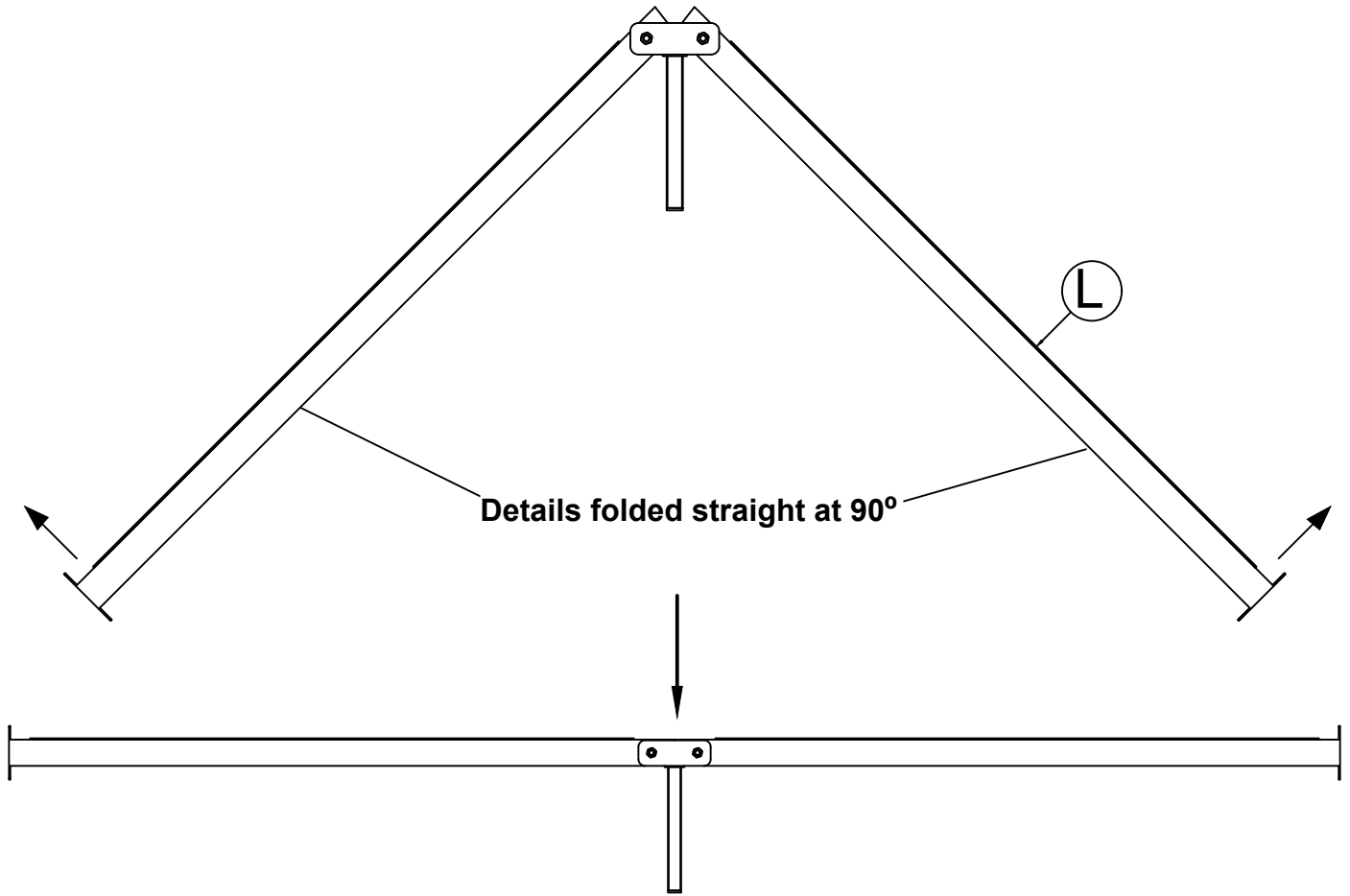

Step 4

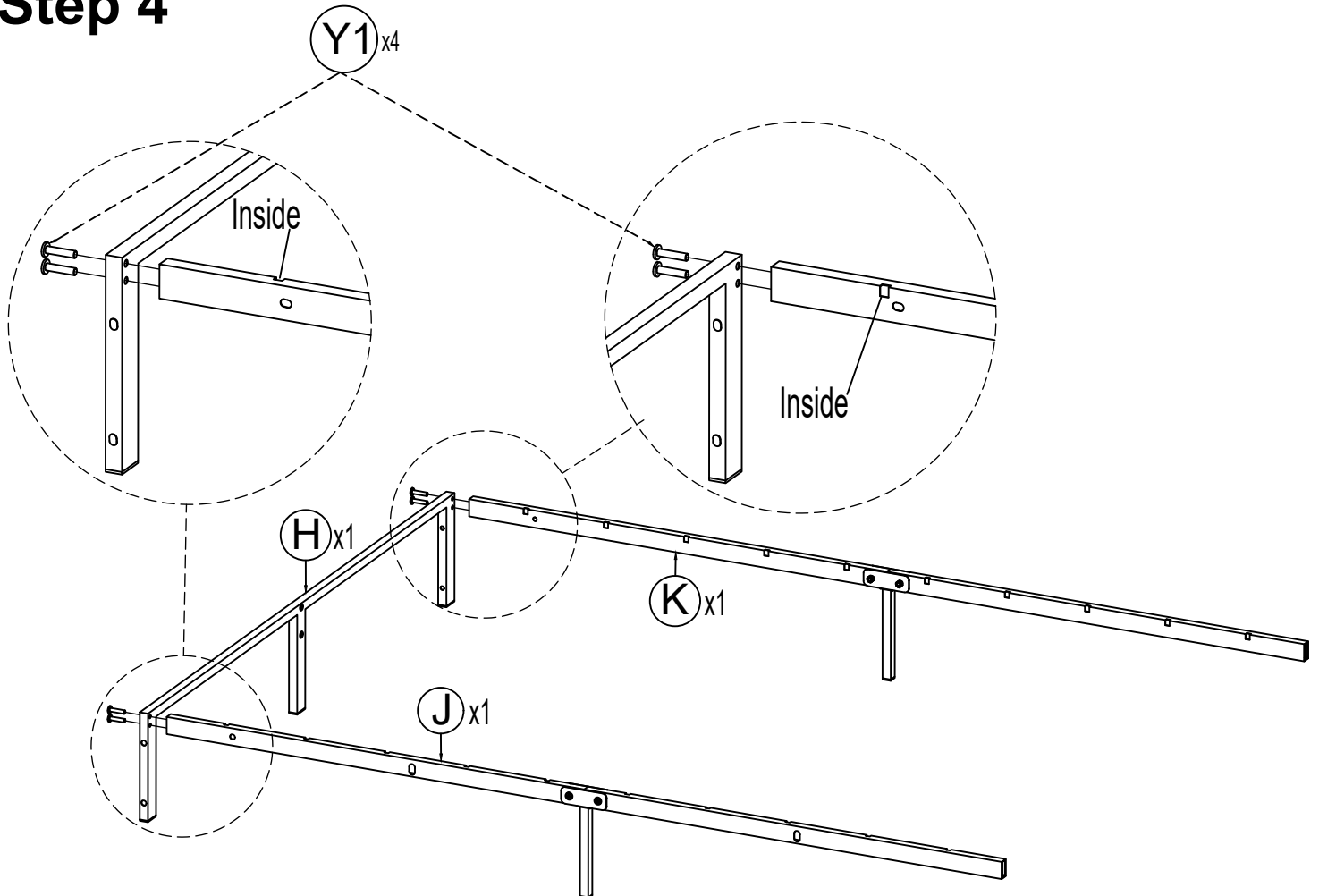

Step 5

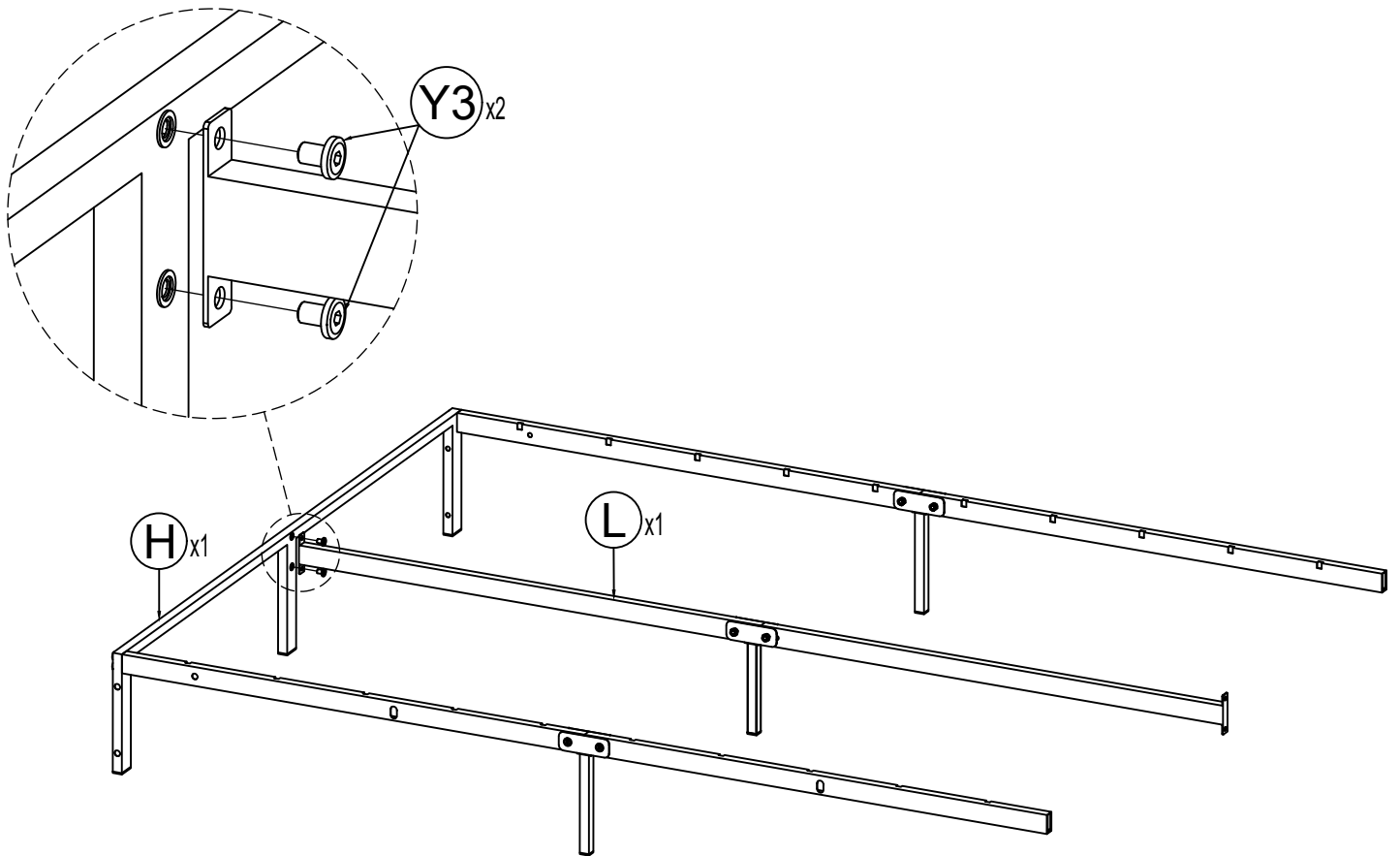

Step 6

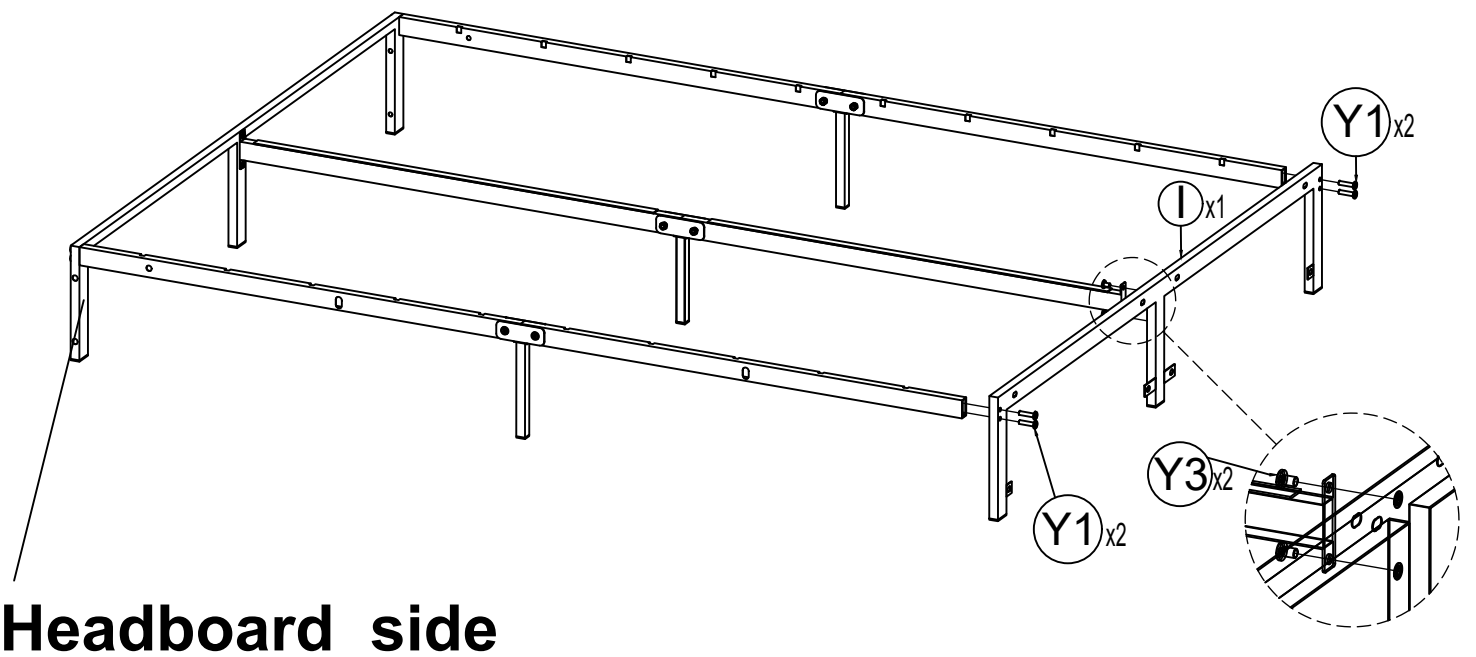

Step 7

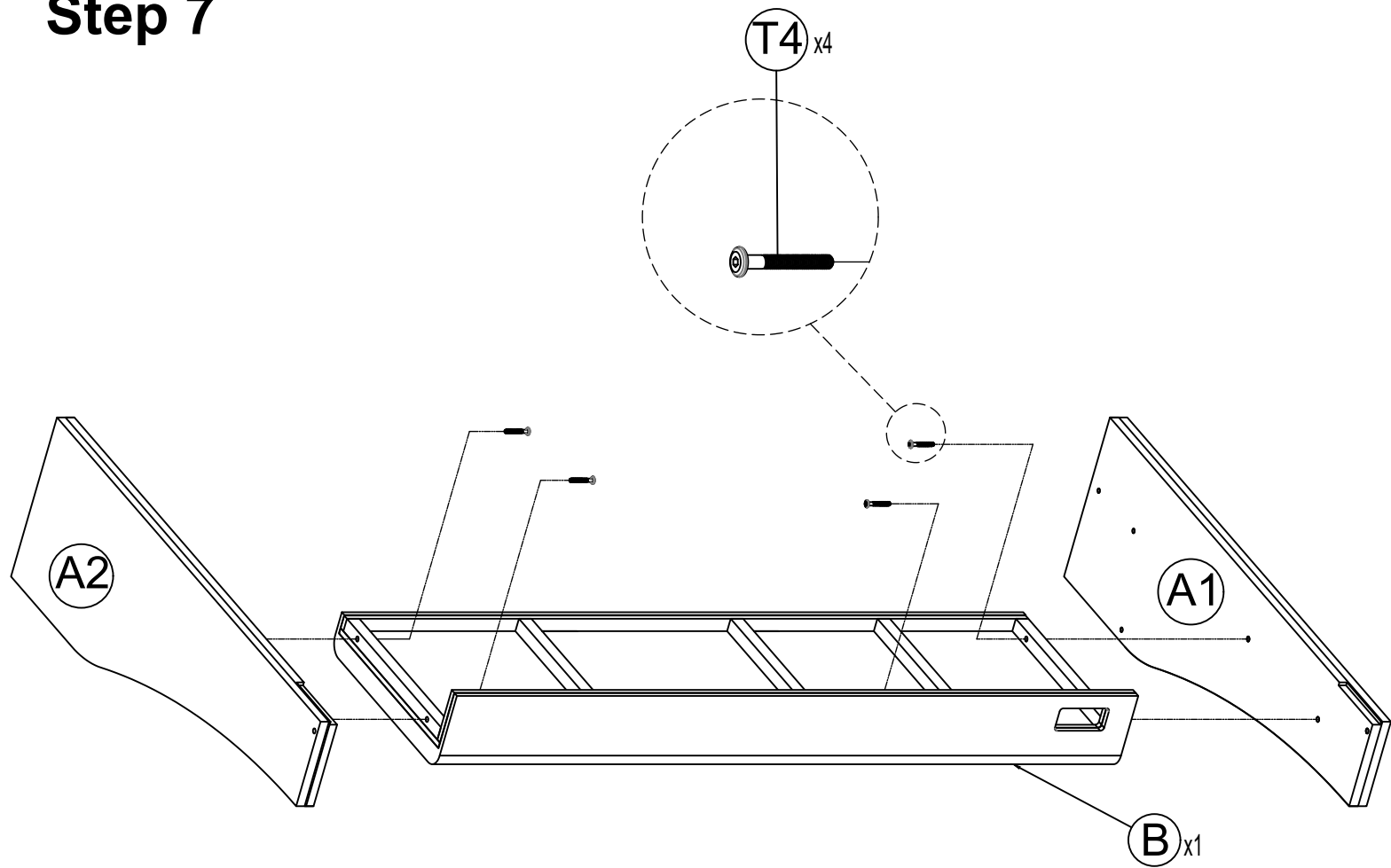

Step 8

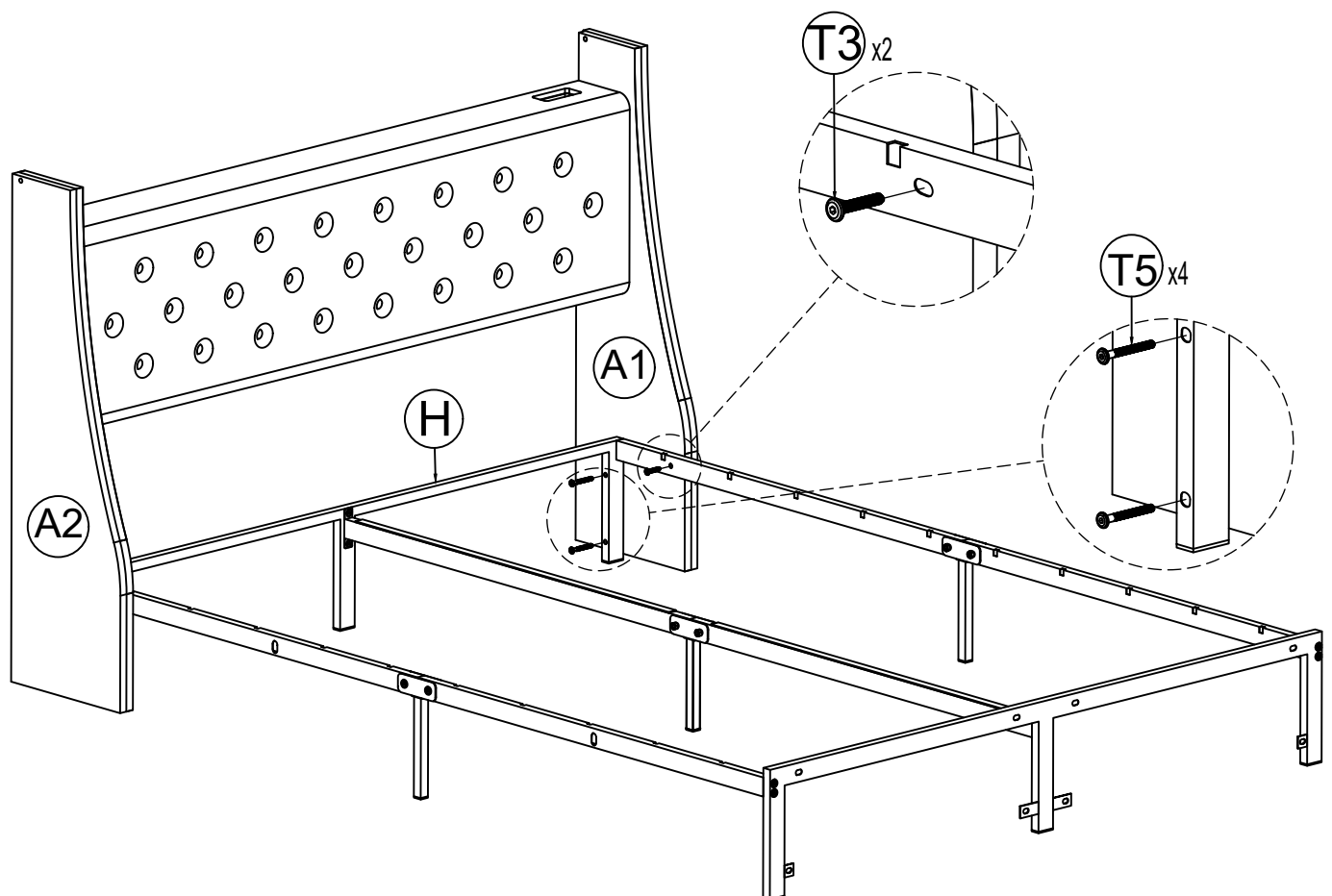

Step 9

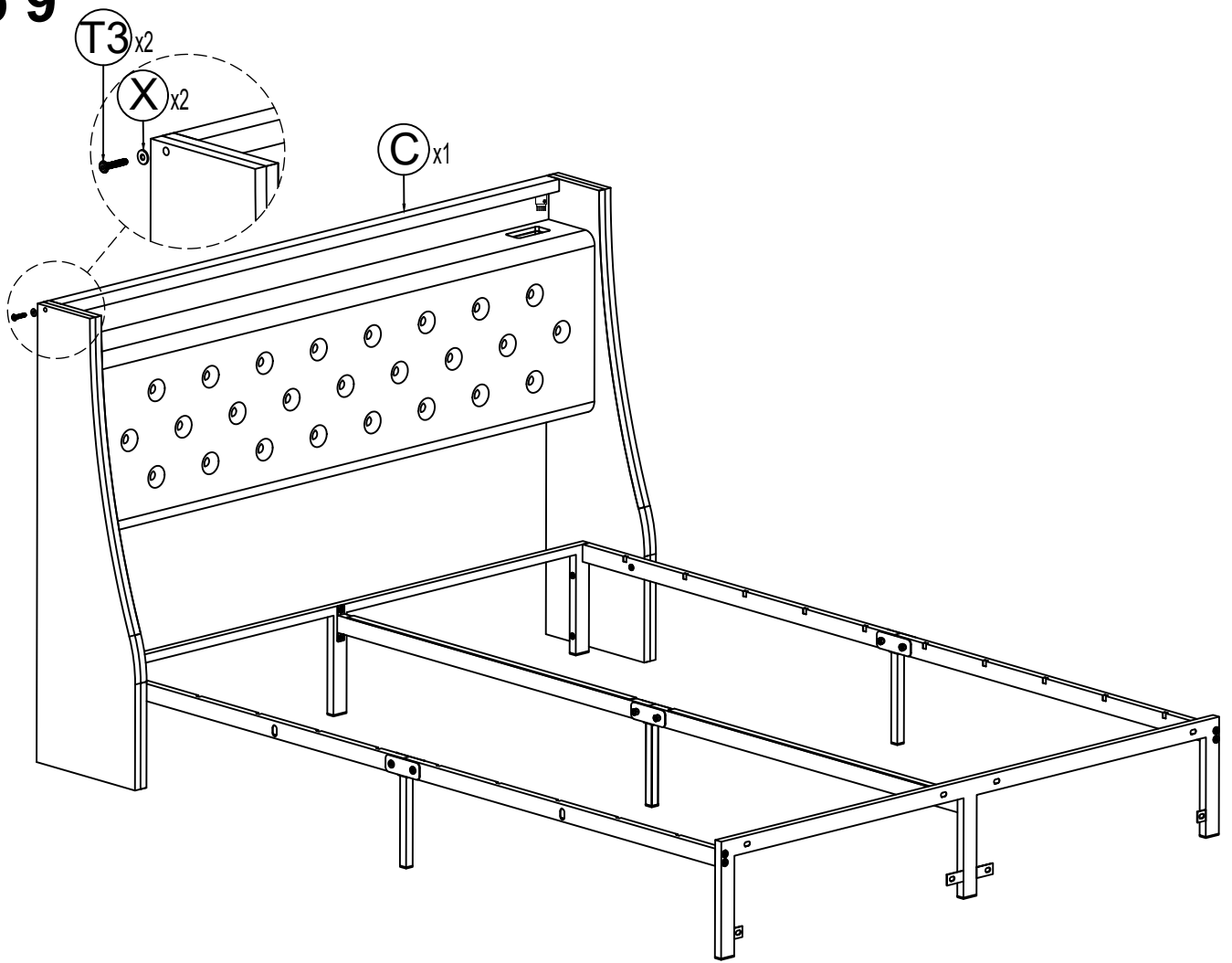

Step 10

We suggest using drill machine to install "V" screws

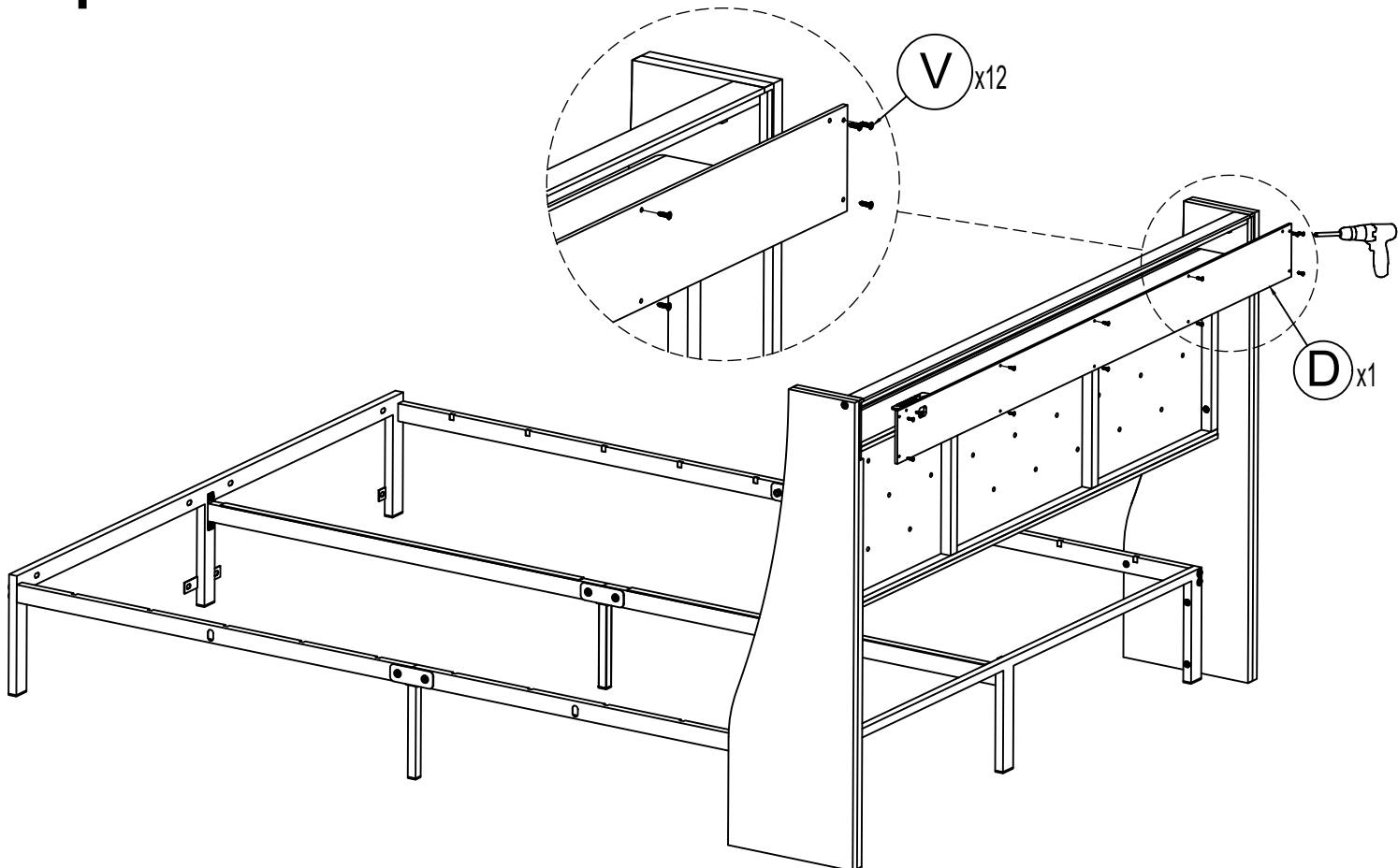

Step 11

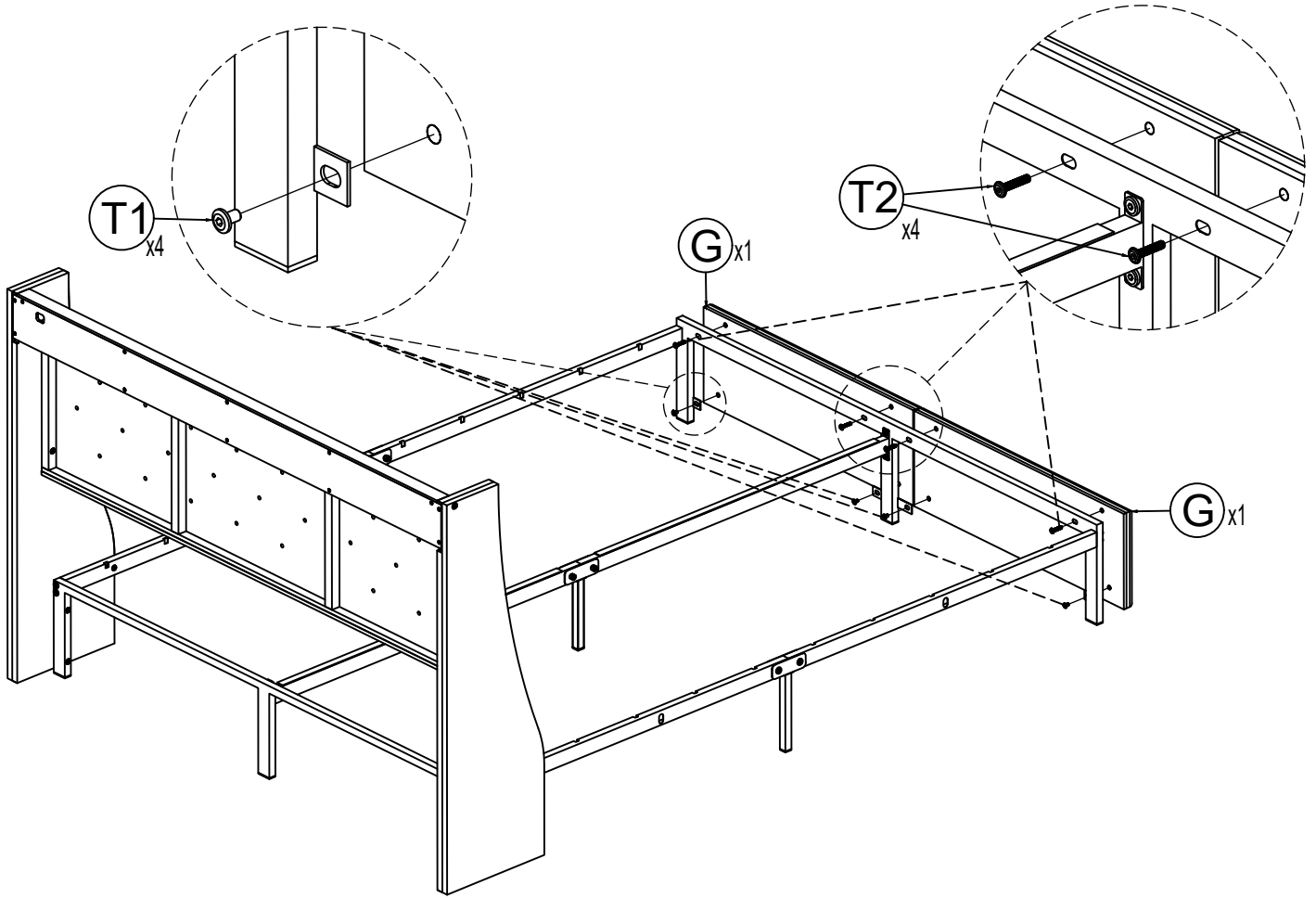

Step 12

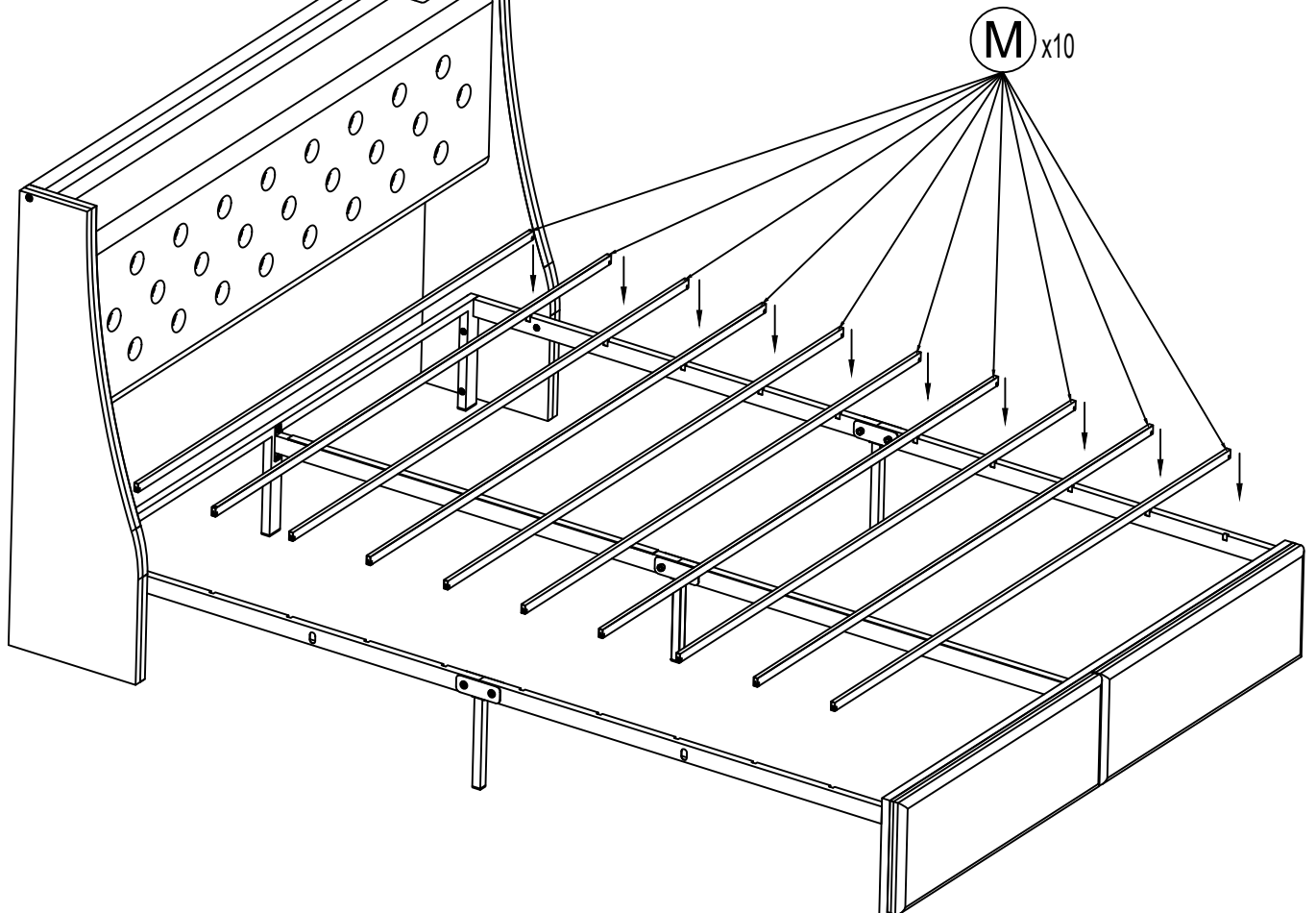

Step 13

U1 x1

We suggest using drill machine to install "V" screws

Tear off the double-sided adhesive tape on U1.

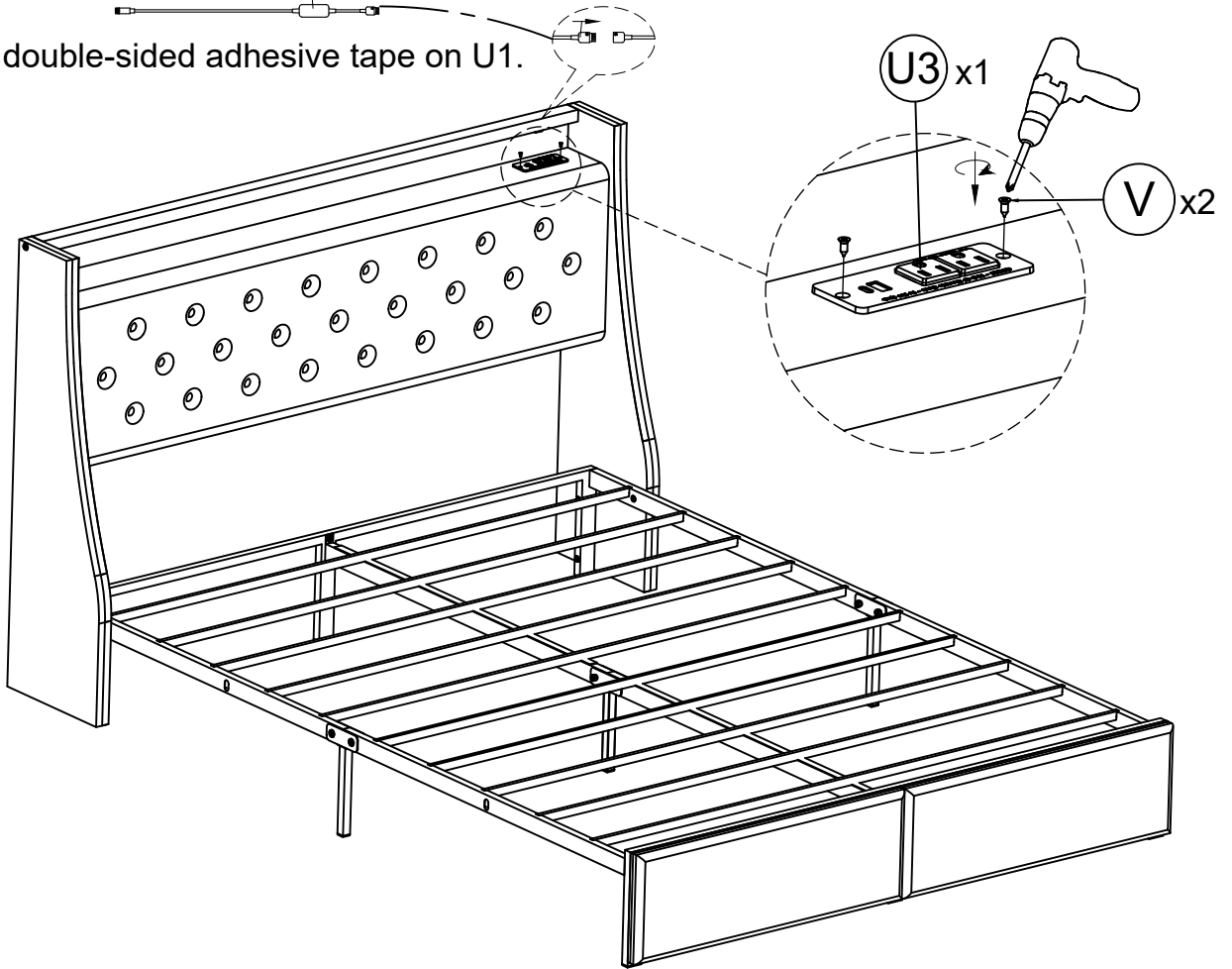

Step 14

Wheel mounting position

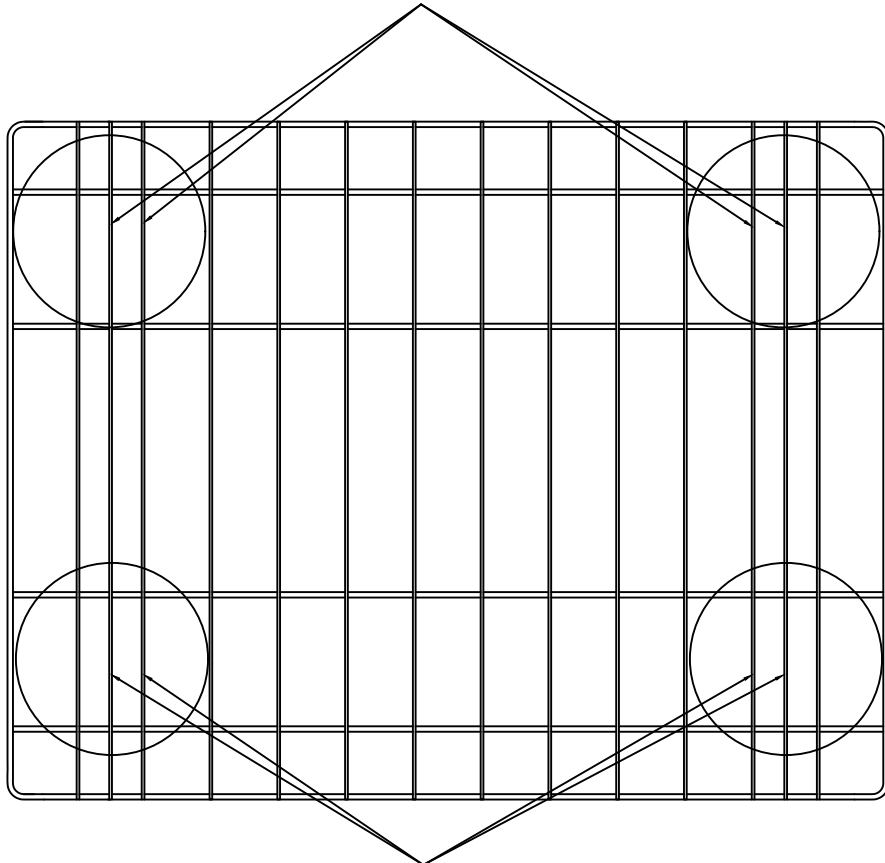

Wheel mounting position

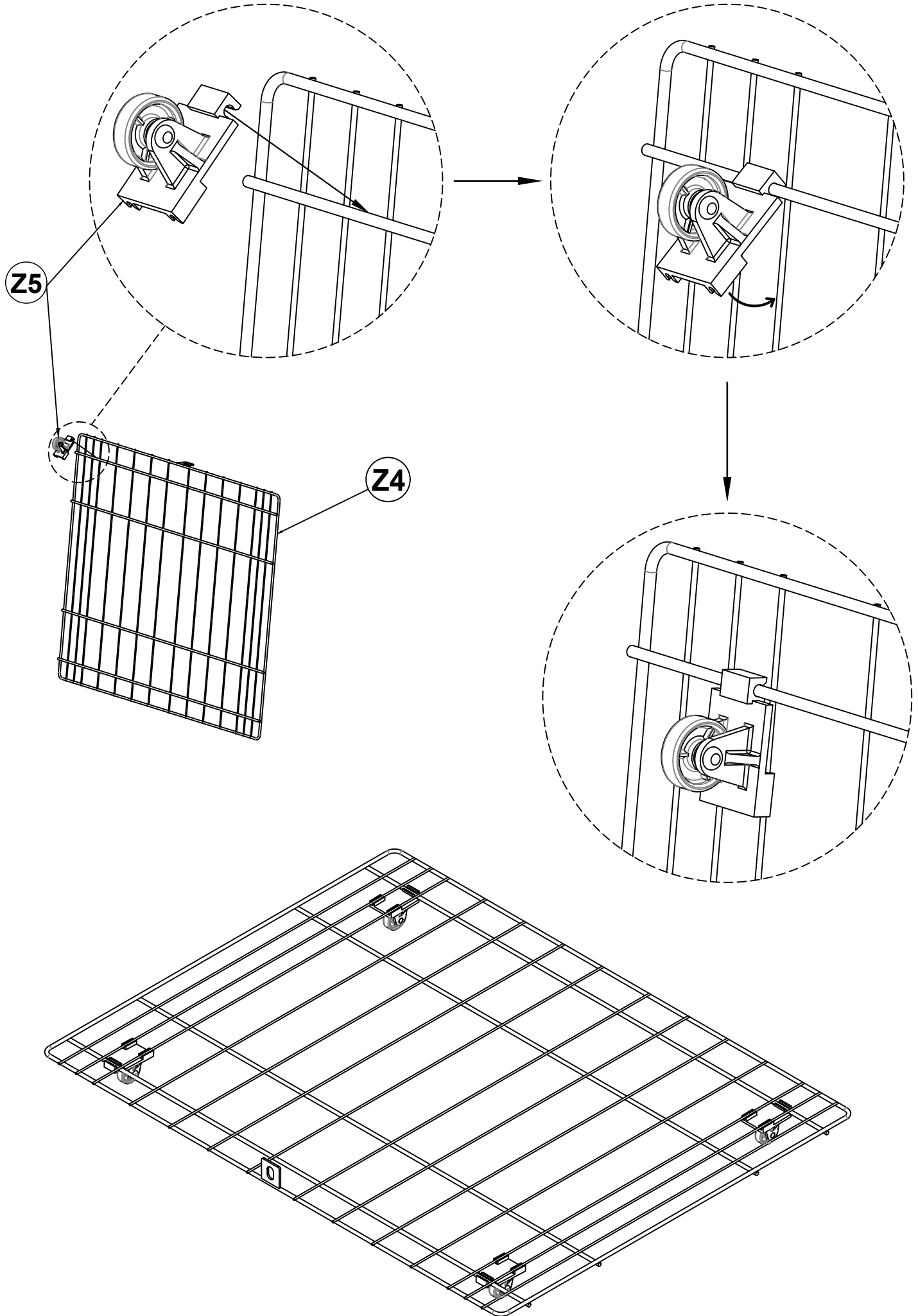

Detailed assembly instructions Q1

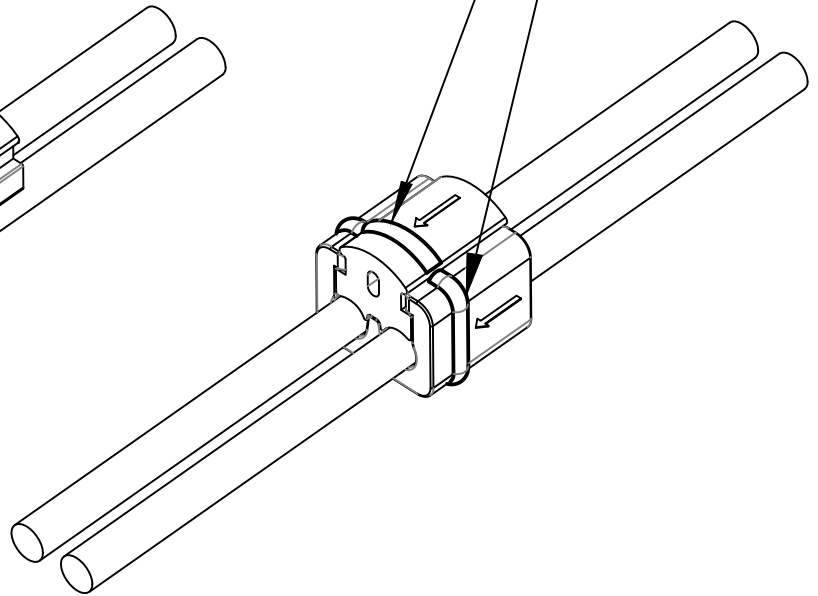
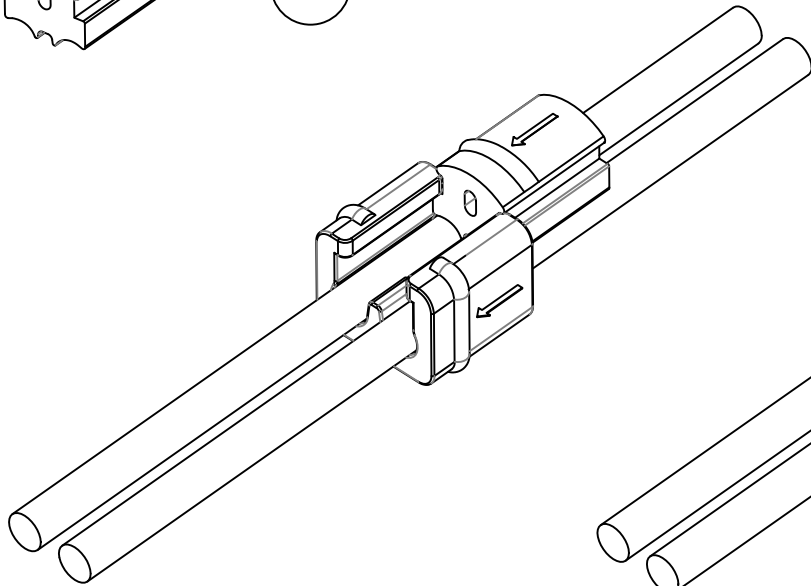
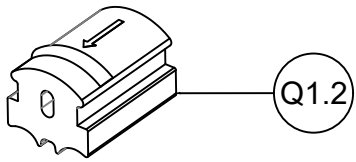
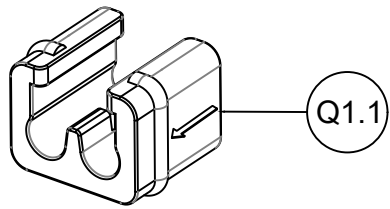

these two
lines on Q1.1
and Q1.2 need
to be matched

Step 15

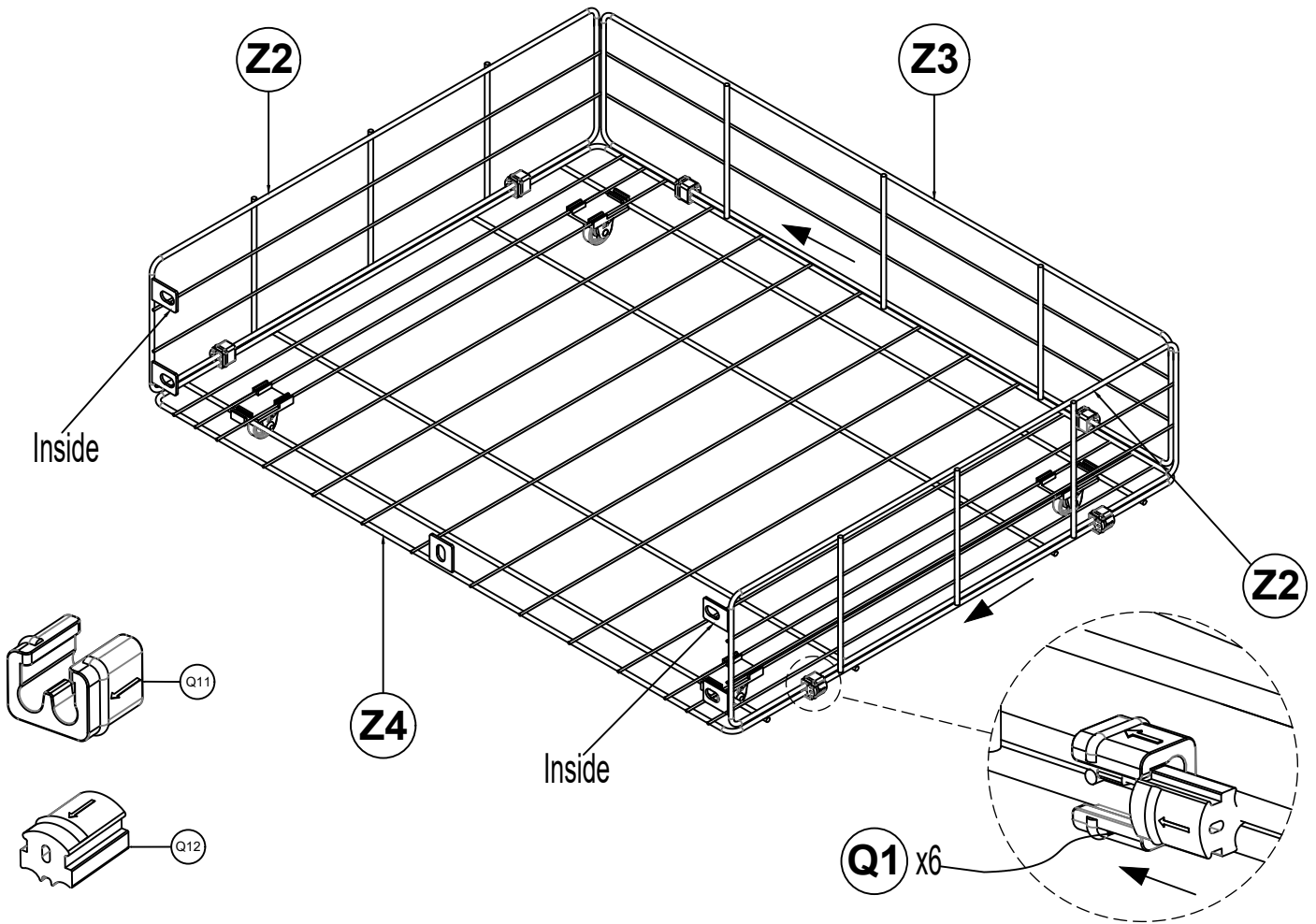

Step 16

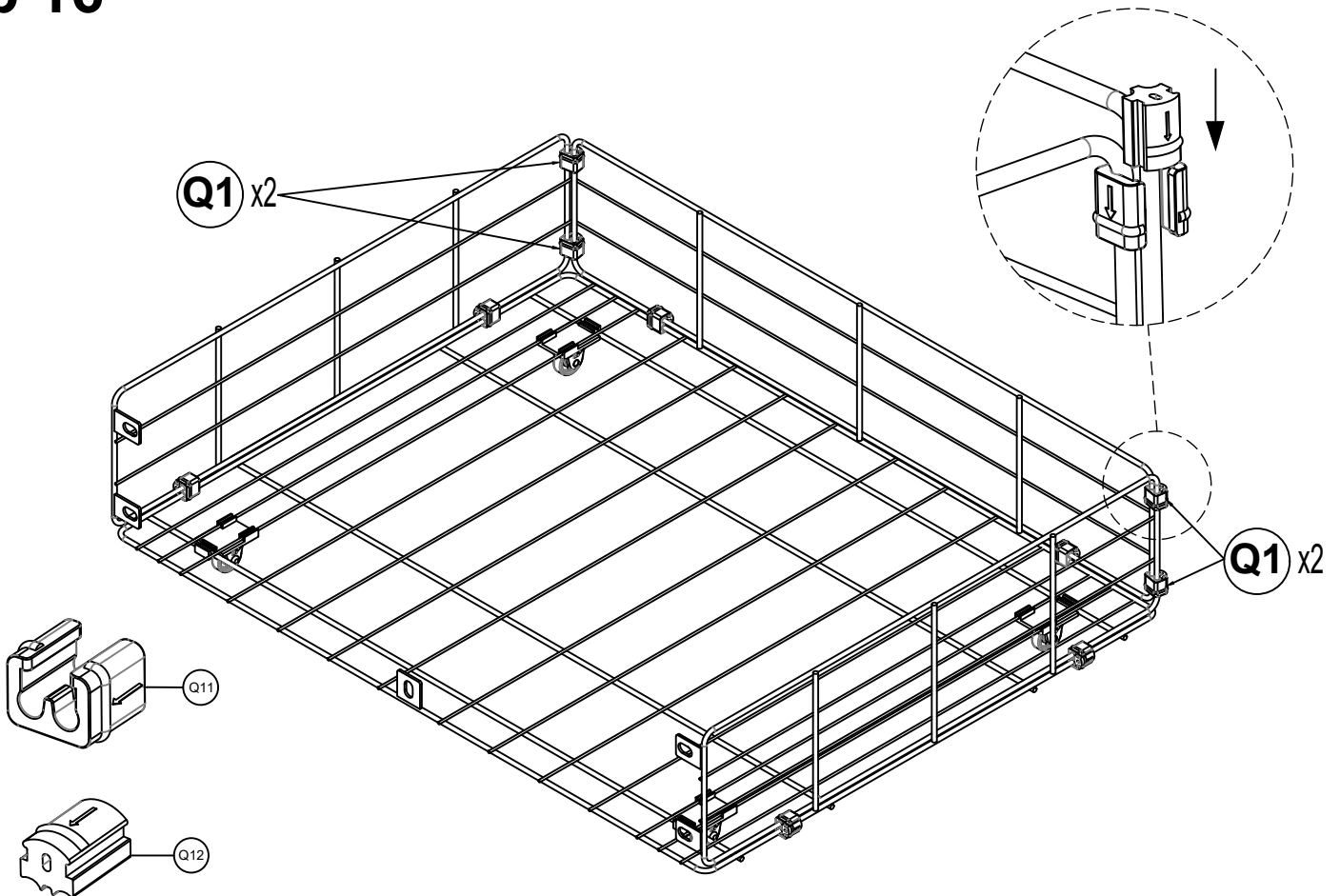

Step 17

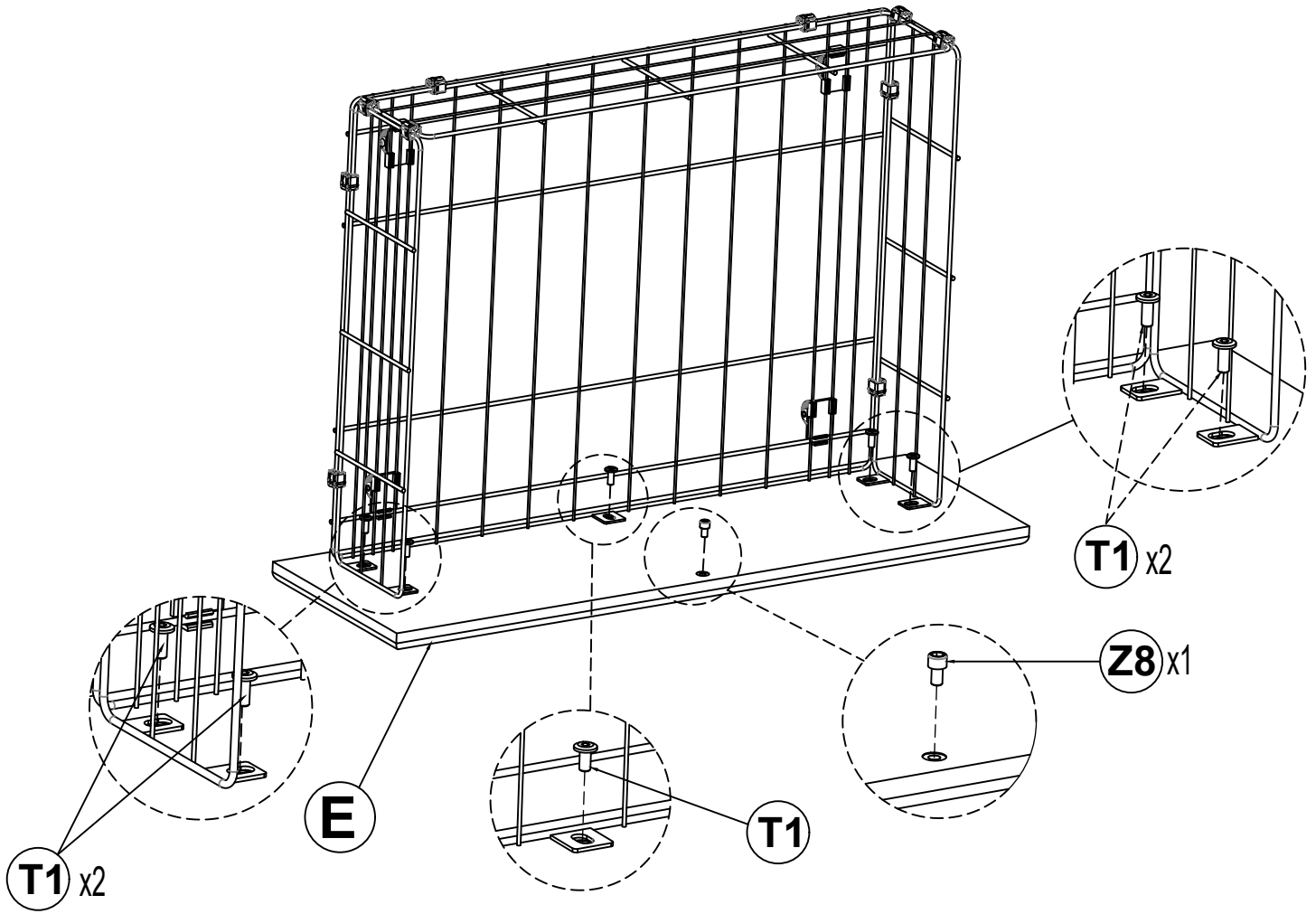

2pcs

E

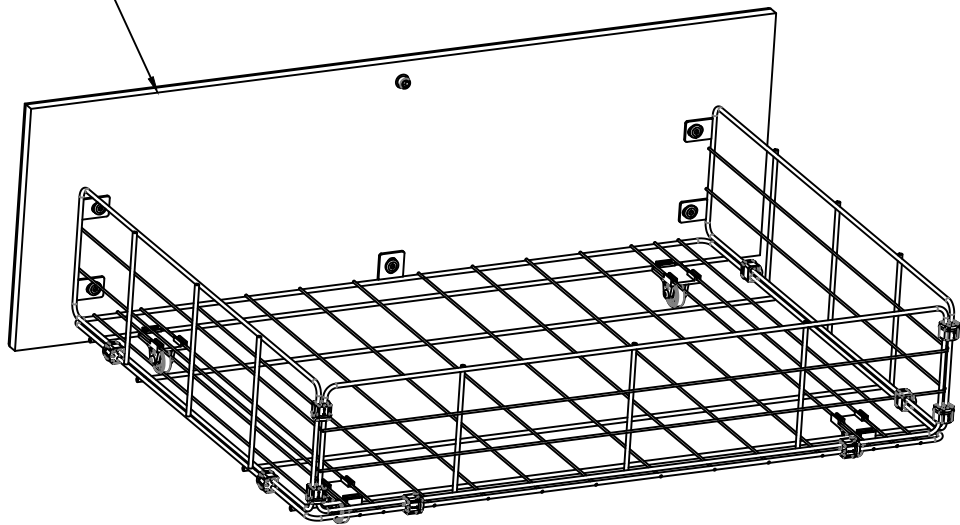

Step 18

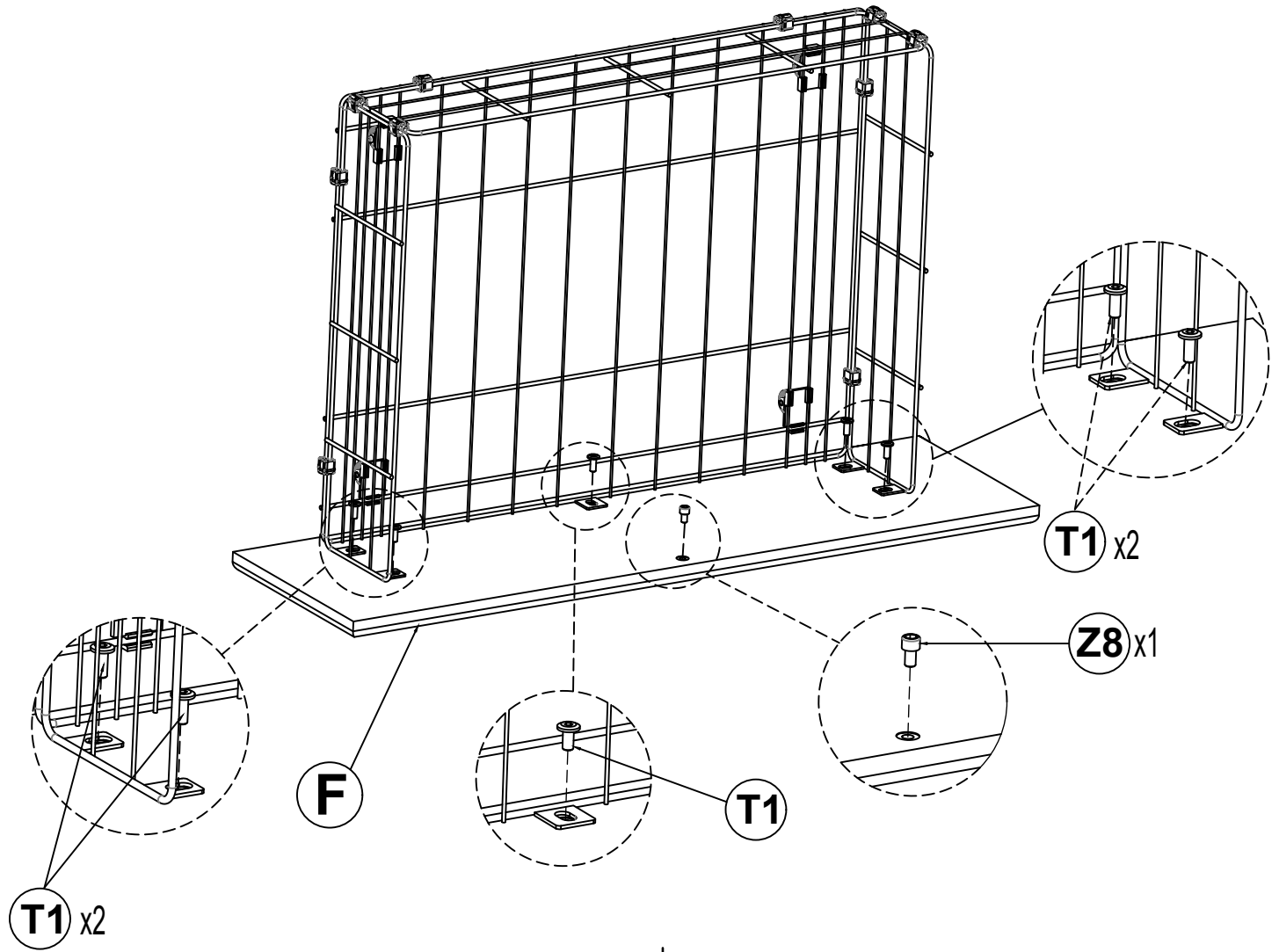

2pcs F

