

ASSEMBLY INSTRUCTIONS

Read this instruction carefully. Refer hardware and furniture parts list for guidance. Be sure all parts are complete, before assembling. Place all wooden furniture part on a clean and flat soft surface to prevent scratches. Refer steps provided as assembling guide.

CAUTIONS :

1. Do not **FULLY-TIGHTEN** the nuts or nut bolts until all are in place.
2. To prevent thread damage. Ensure that nuts or nut bolts are not over-tighten.
3. Hardware are to be kept out of reach from children.

PART LIST			HARDWARE LIST		
ITEM	DESCRIPTION	QTY	ITEM	DESCRIPTION	QTY
A	HEADBOARD UPPER CUSHION	1 PC	1	JCBC SCREW M6 x 35mm	48 PCS
B	HEADBOARD LOWER CUSHION	1 PC	2	JCBC SCREW M6 x 50mm	3 PCS
C	FOOTBOARD	1 PC	3	SPRING WASHER 1 /4"	51 PCS
D	SIDERAIL	2 PCS	4	FLAT WASHER 1 /4"	48 PCS
E	SLAT (with Belt)	14 PCS	5	JCBB SCREW M8 x 80mm	12 PCS
F	CENTER SLAT	1 PC	6	SPRING WASHER 5 /16"	12 PCS
G	CENTER SLAT SUPPORT	3 PCS	7	FLAT WASHER 5 /16"	12 PCS
H	PILLAR HEADBOARD (L&R)	2 PCS	8	ALLEN KEY M5	1 PC
I	PILLAR FOOTBOARD	2 PCS	9	ALLEN KEY M4 (BALL SHAPE)LONG	1 PC
J	SIDERAIL RAIL	2 PCS	10	ADJUSTABLE SCREW	3 PCS
K	HEADBOARD RAIL	1 PC	11	PAN HEAD SCREW M4 x 25MM	6 PCS
L	FOOTBOARD RAIL	1 PC			
M	CORNER BLOCK	4 PCS			

STEP 1

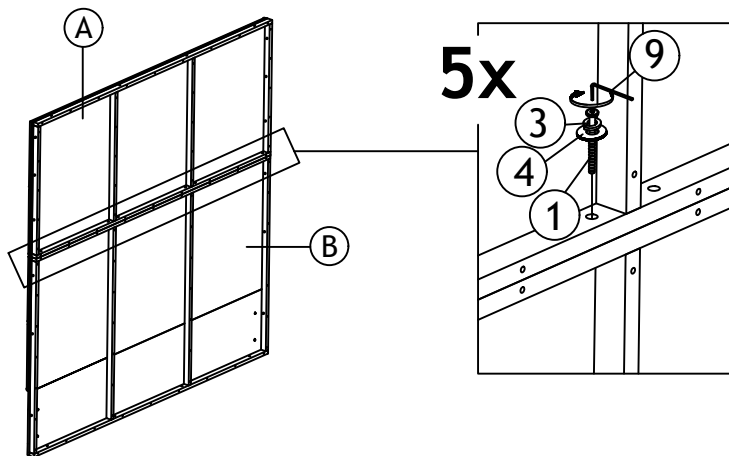

STEP 2

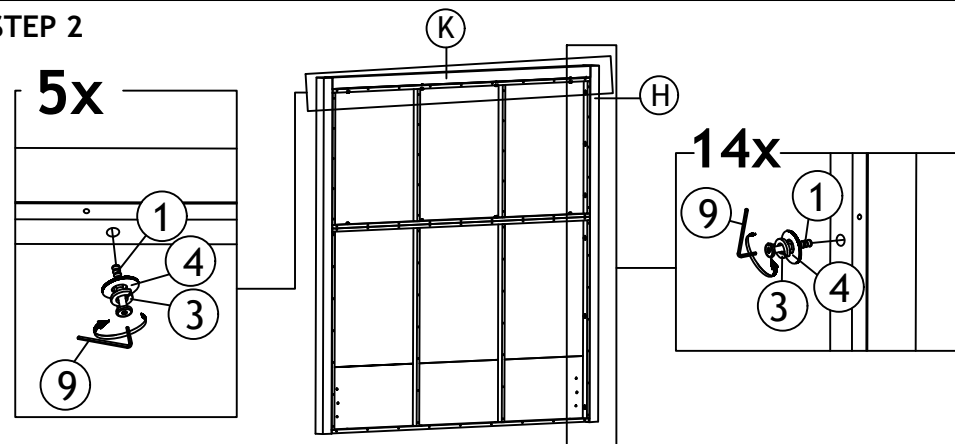

STEP 3

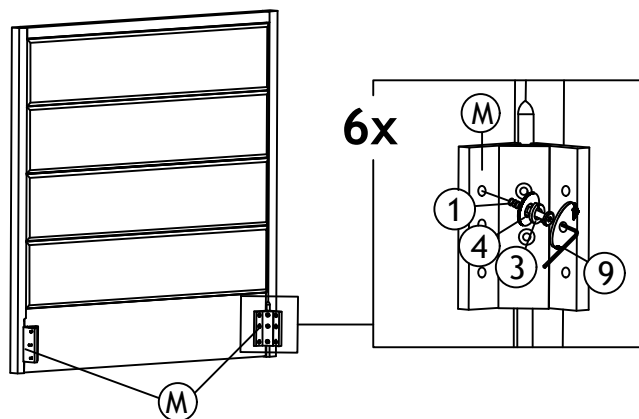

STEP 4

