

# ASSEMBLY INSTRUCTIONS

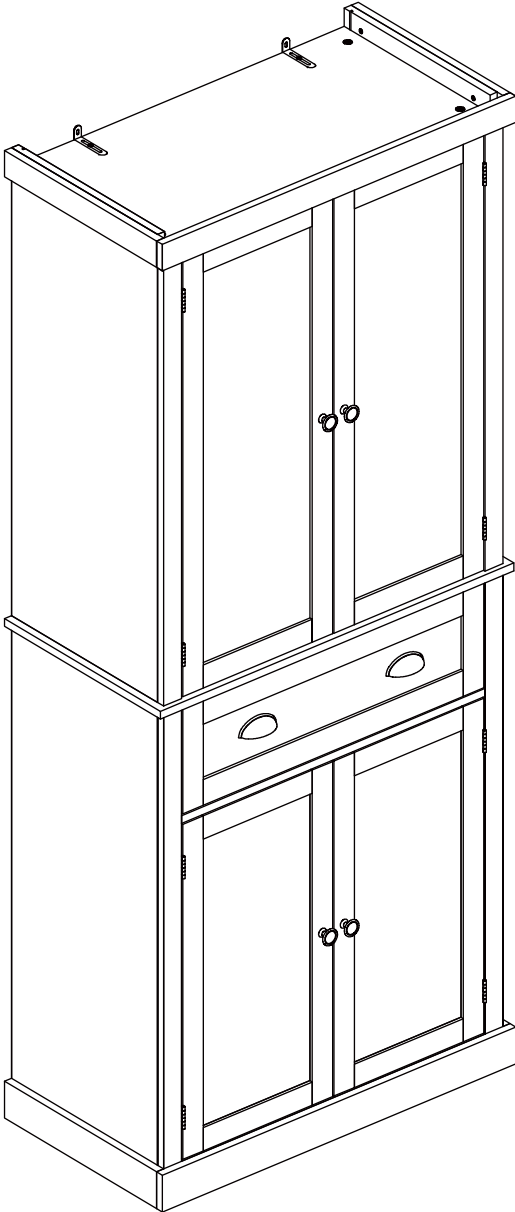

# WARNING!

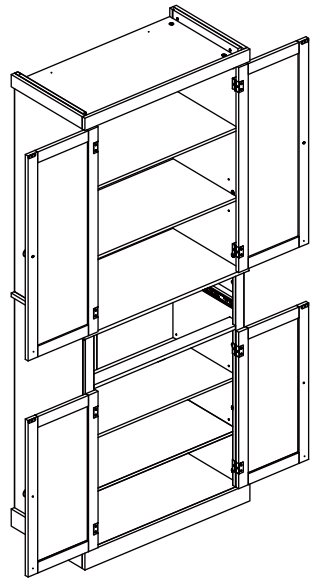

Estimated Time for Assembly

**90 mins**



Weight Limitation

**58lb** Shelf overall

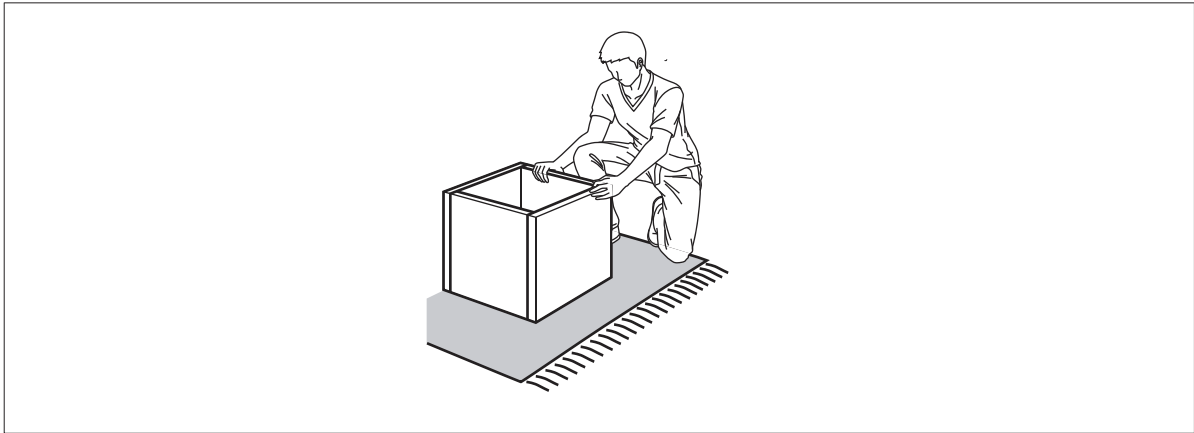

Assemble the furniture on empty carton, carpet, or rug to prevent scratches or damage.

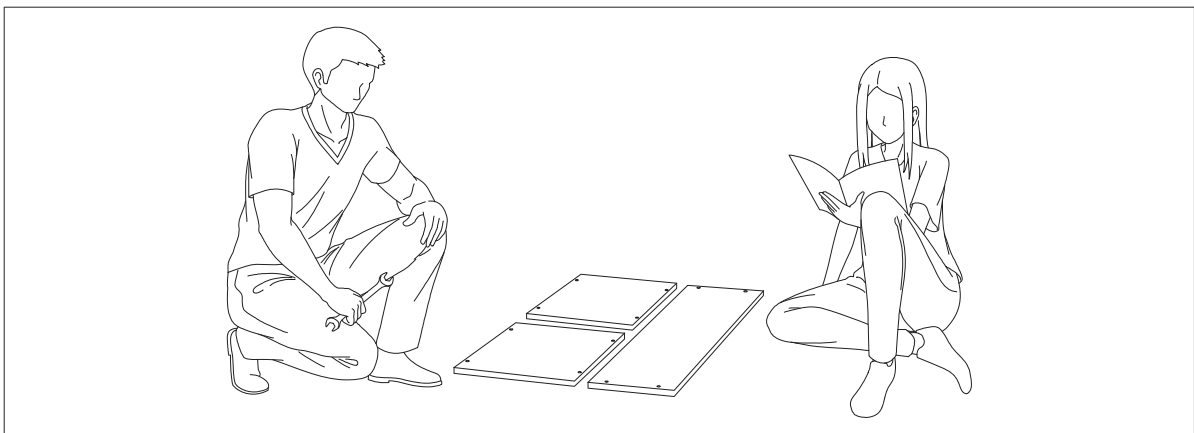

This furniture requires 2 people to assemble.

Make sure no parts are missing or damaged before assemble

# Board Identification

Not actual size

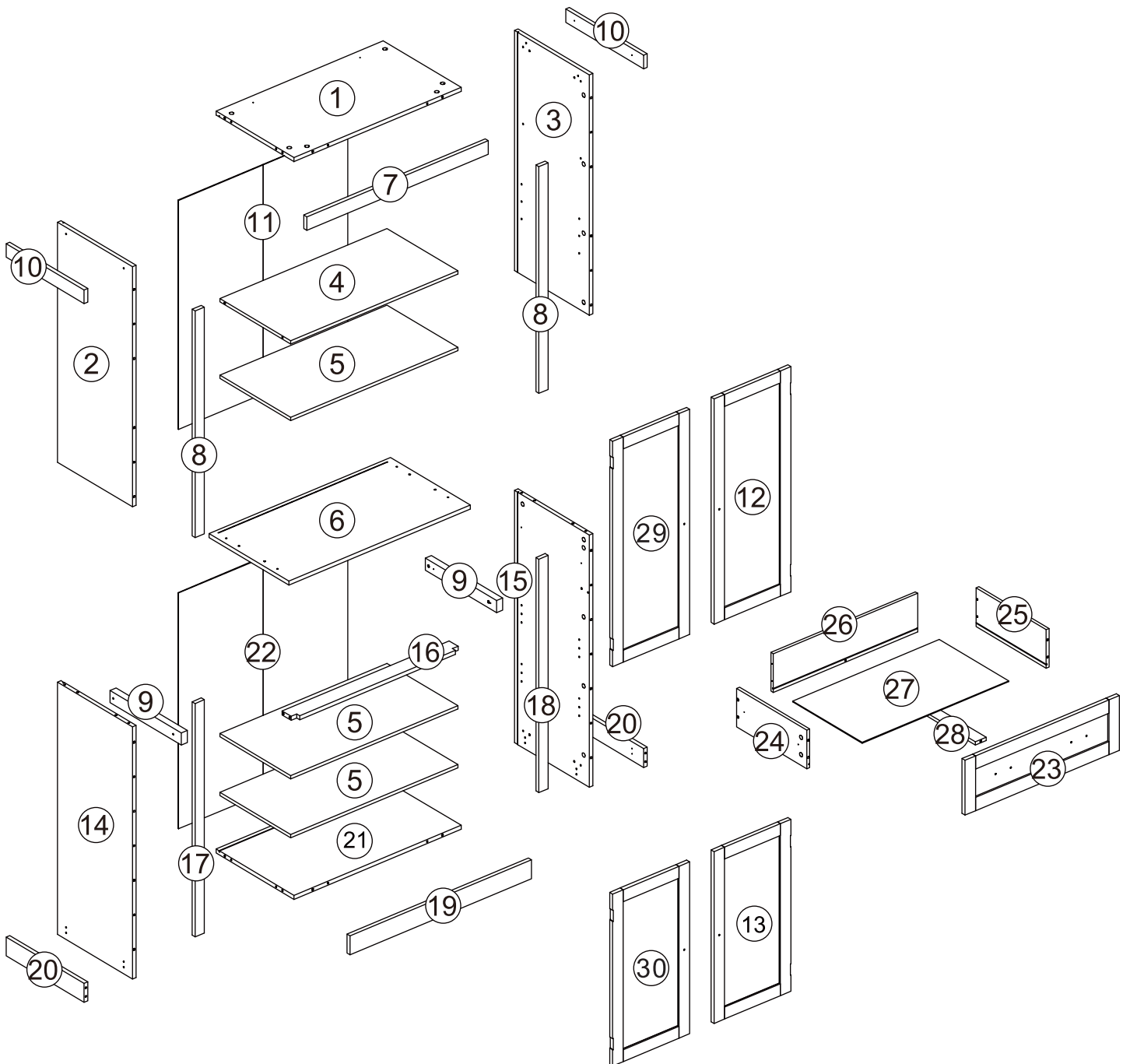

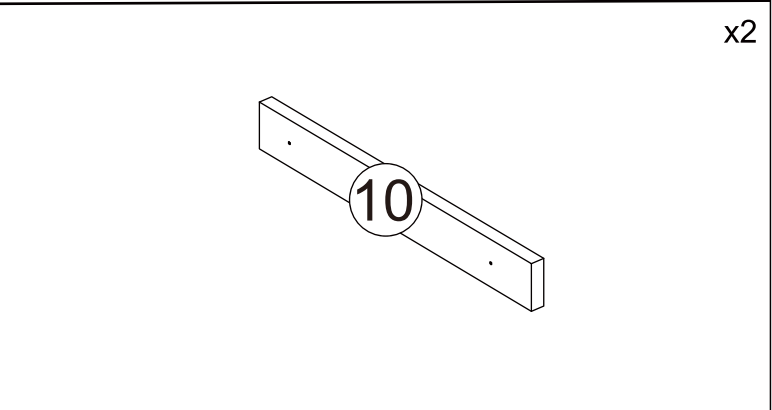
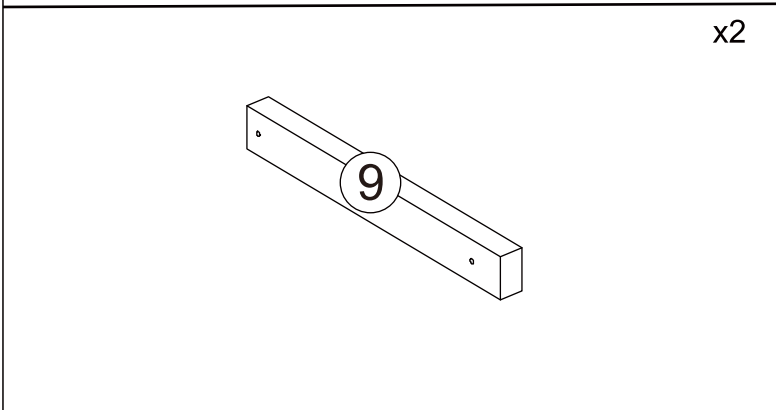
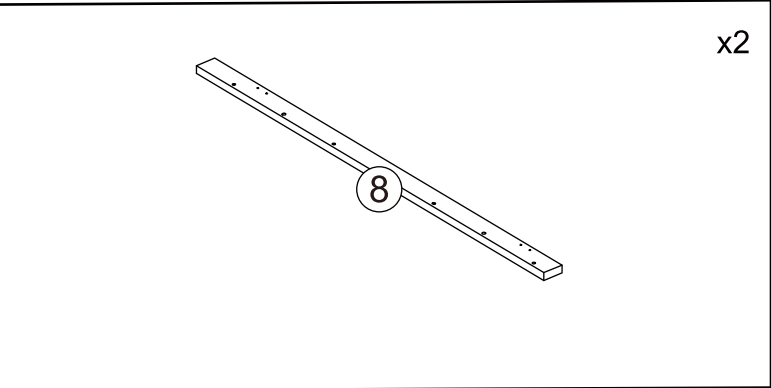
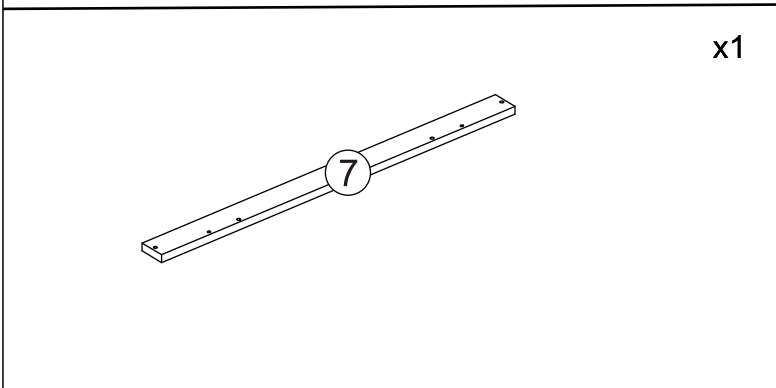
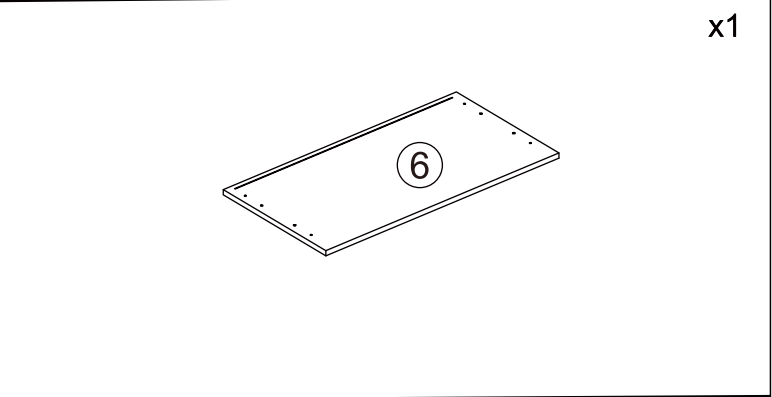
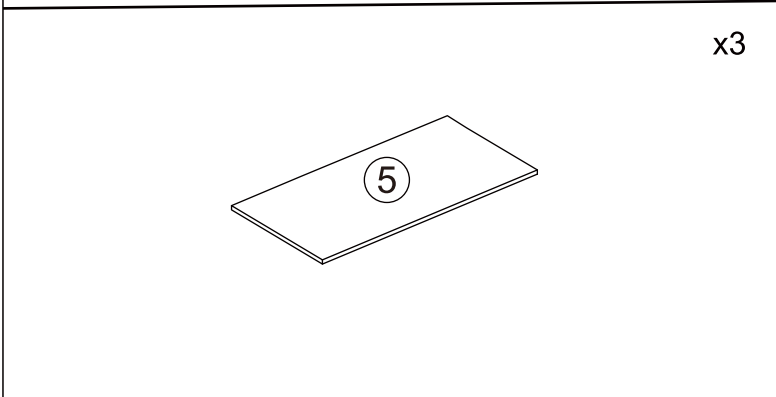
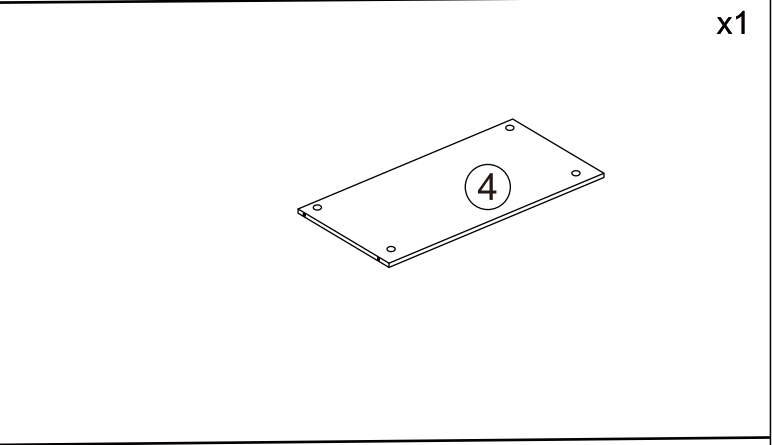
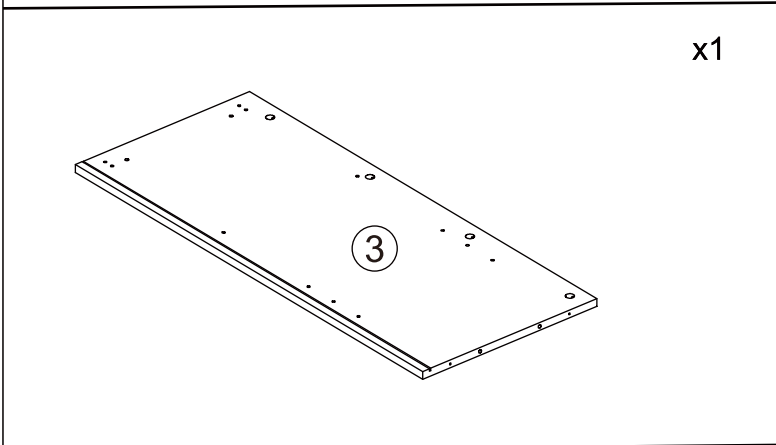
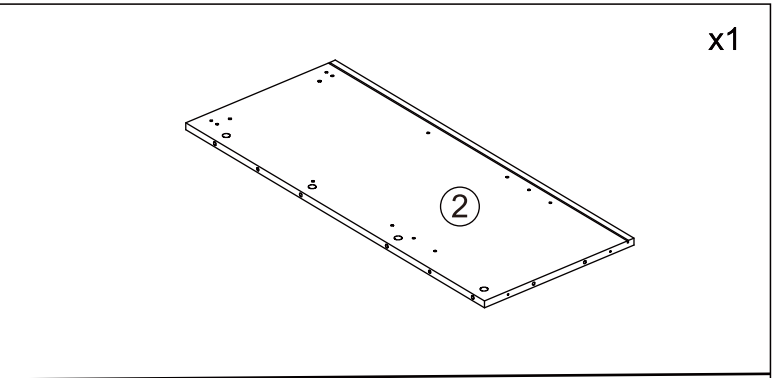
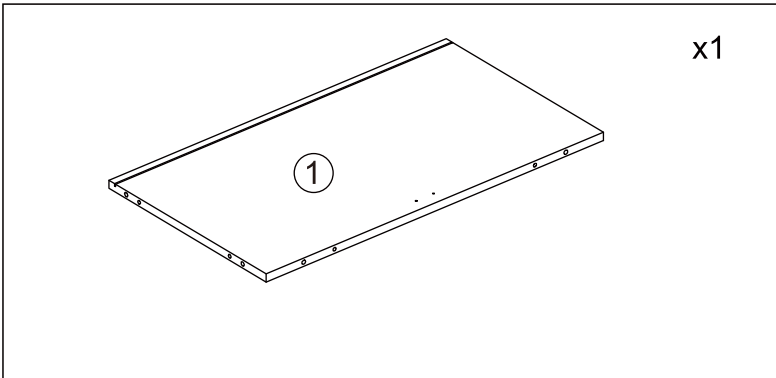

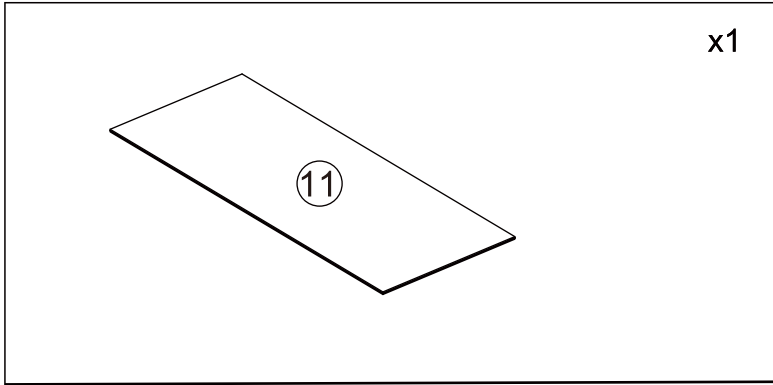

x1

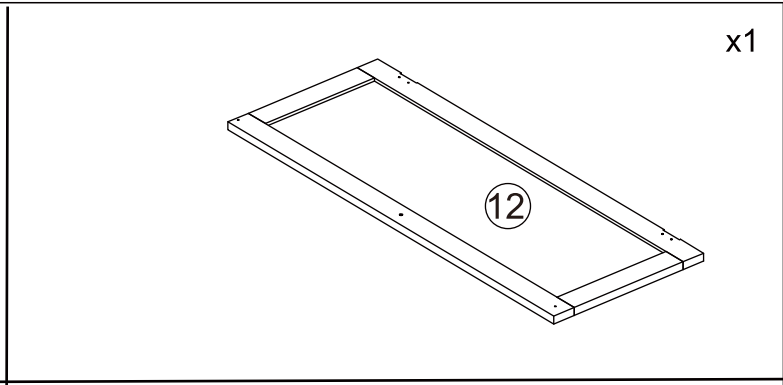

x1

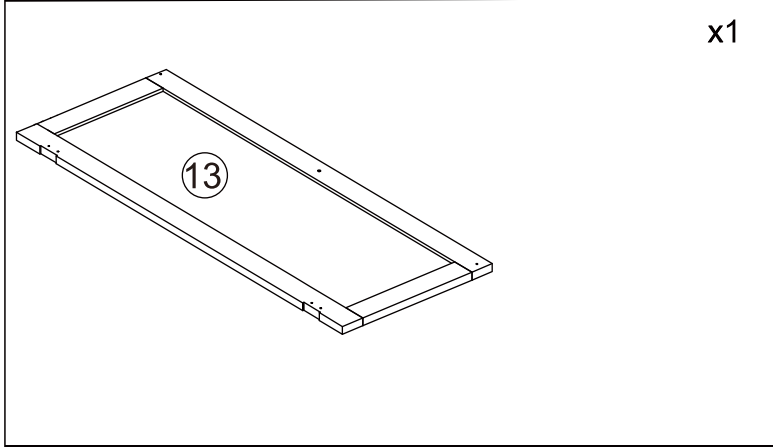

x1

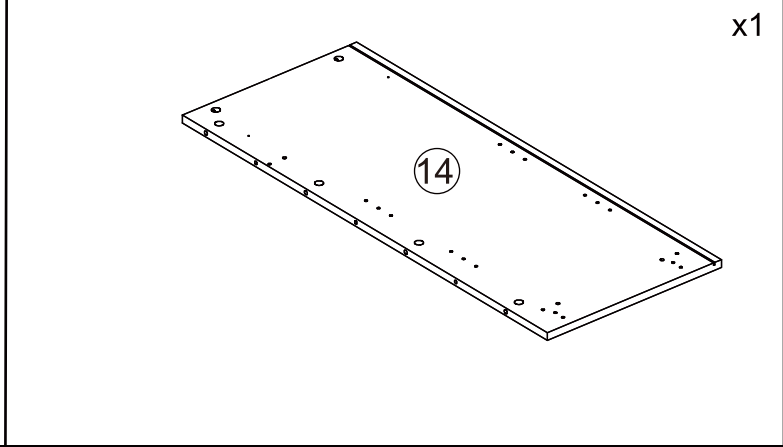

x1

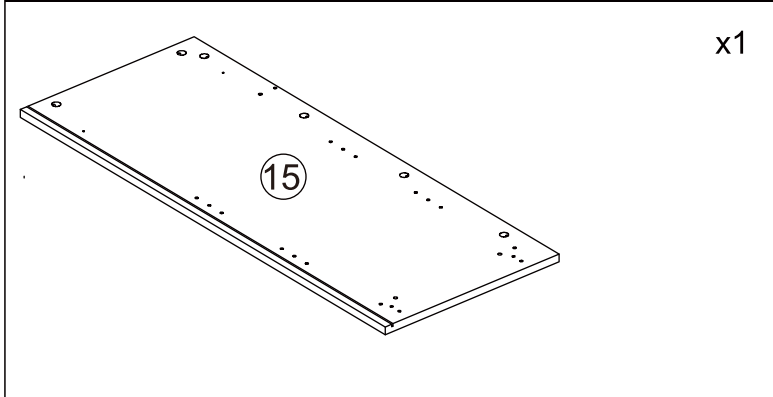

x1

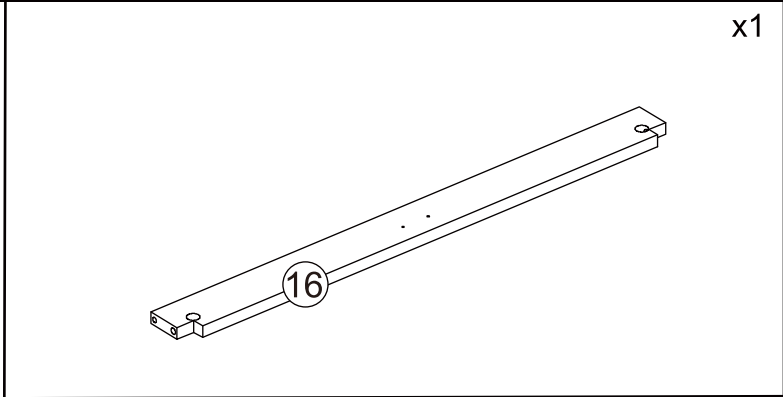

x1

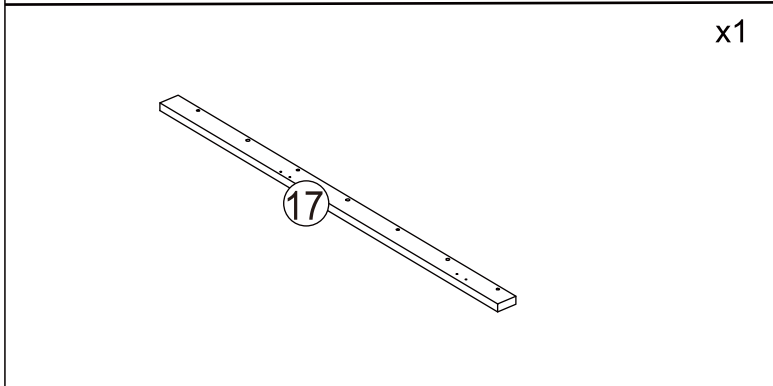

x1

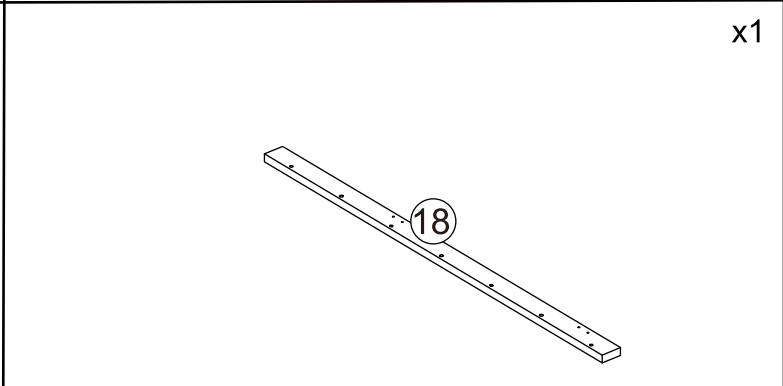

x1

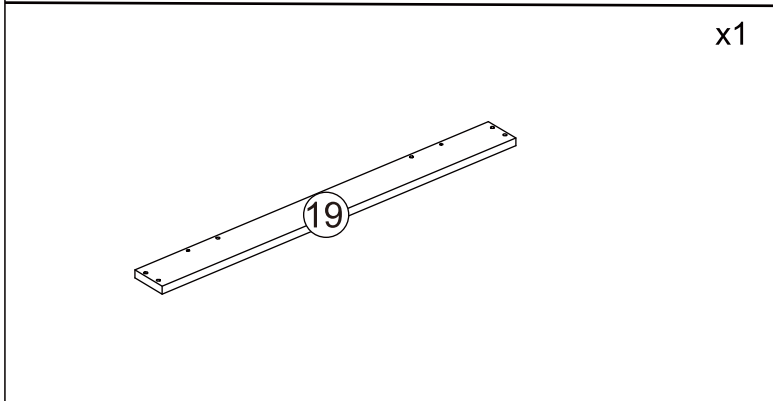

x1

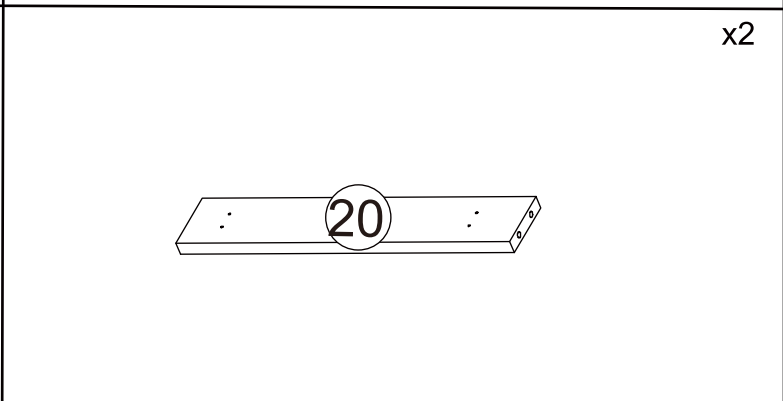

x2

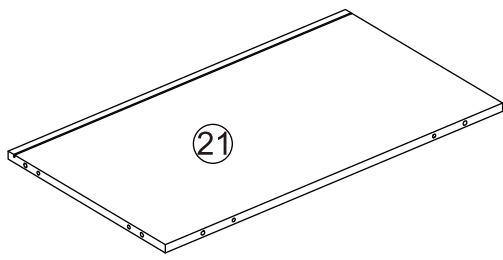

x1

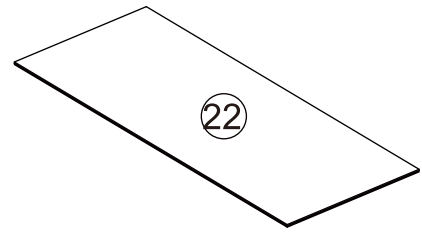

x1

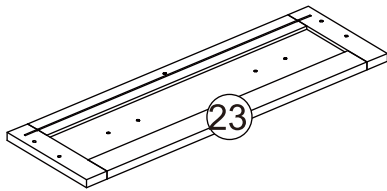

x1

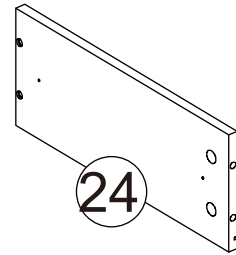

x1

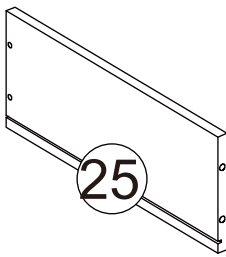

x1

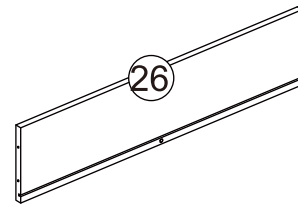

x1

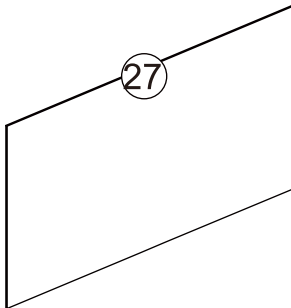

x1

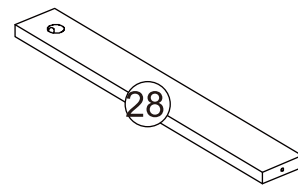

x1

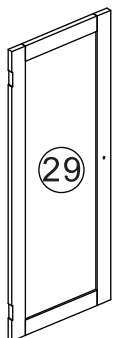



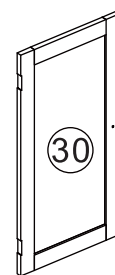







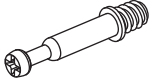

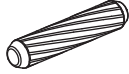
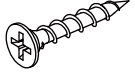
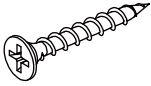
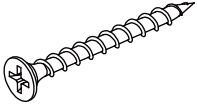
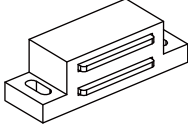
x1

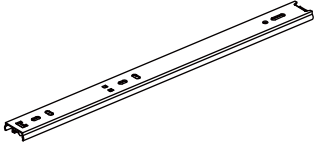
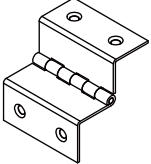
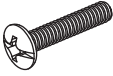

x1

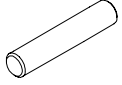
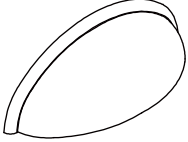
# Hardware List

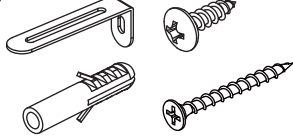
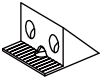
Actual size

			 Ø4x25mm
<b>A</b> 43+2PCS	<b>B</b> 43+2PCS	<b>C</b> 40+2PCS	<b>D</b> 12PCS
 Ø4x30mm	 Ø4x40mm		
<b>E</b> 9PCS	<b>F</b> 4PCS	<b>G</b> 2PCS	<b>H</b> 4PCS
 Ø3x16mm	 Ø3x14mm	 Ø3x12mm	
<b>J</b> 16PCS	<b>K</b> 36PCS	<b>L</b> 8PCS	<b>M</b> 2PCS
	 M4x16mm		 Ø5x20mm
<b>N</b> 8PCS	<b>O</b> 4PCS	<b>P</b> 4PCS	<b>Q</b> 12PCS
	 M4x6mm		
<b>R</b> 2PCS	<b>S</b> 4PCS	<b>T</b> 2PCS	<b>U</b> 12PCS
			
<b>V</b> 1PC			

# STEP 1

■ Step 1-11 Install the upper parts.

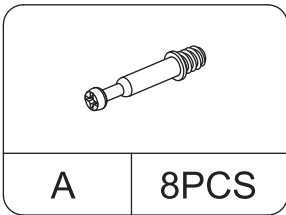
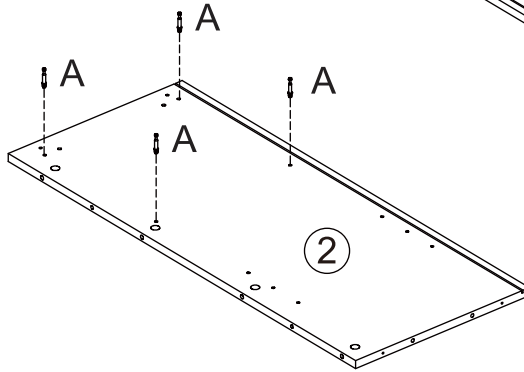
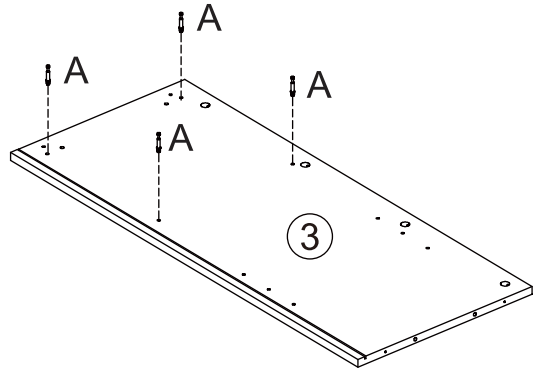
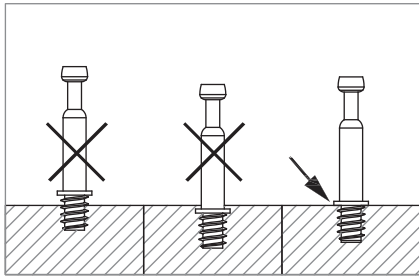
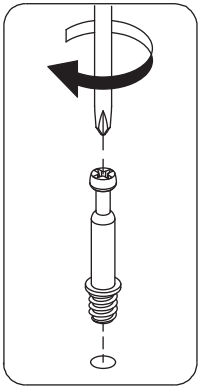

# STEP 2

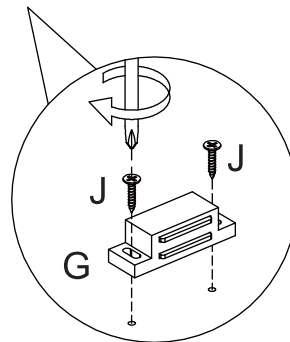
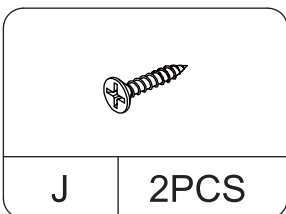
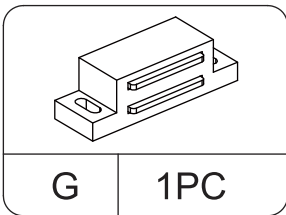
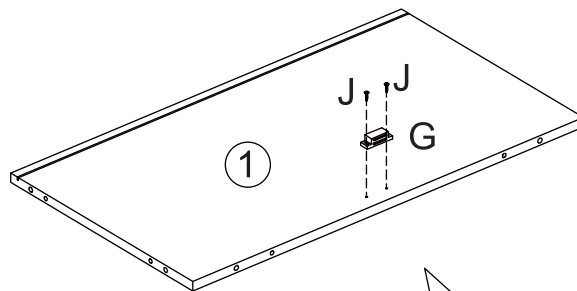

# STEP 3

Push a CAM LOCK into the part  
The arrow in the CAM LOCK  
must point toward the hole on the  
edge of the board

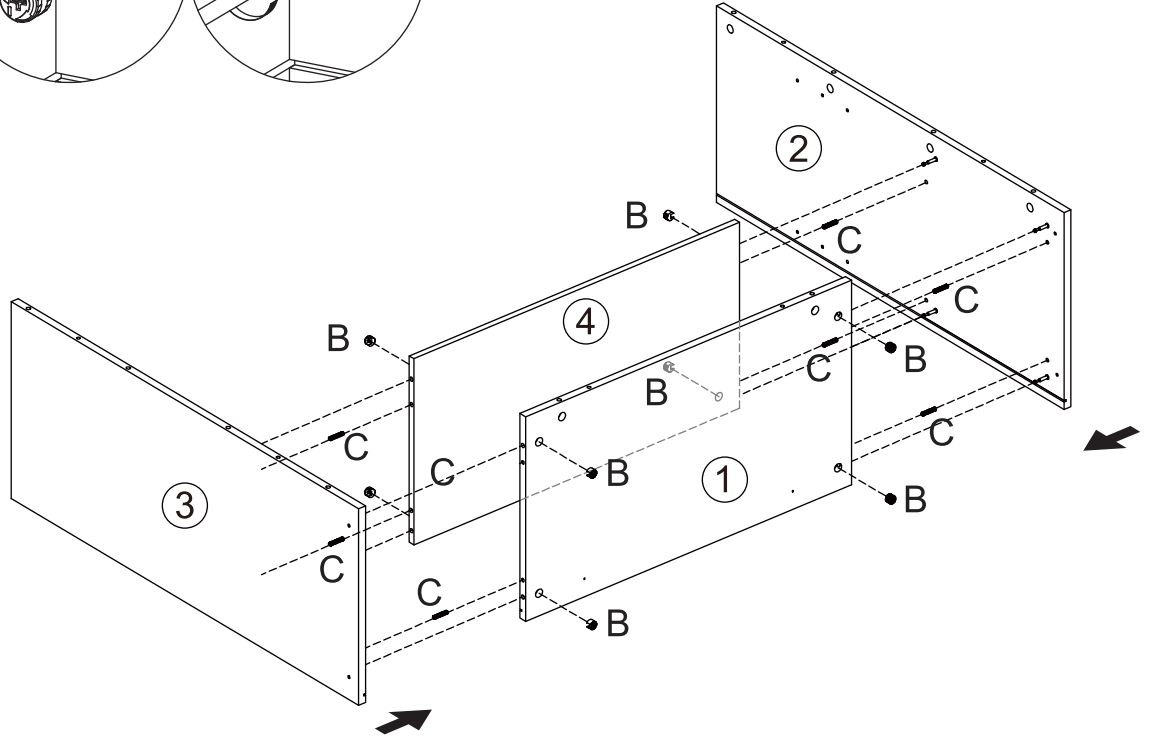
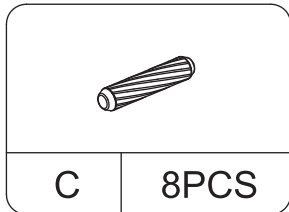
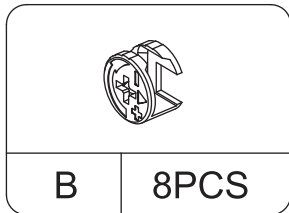
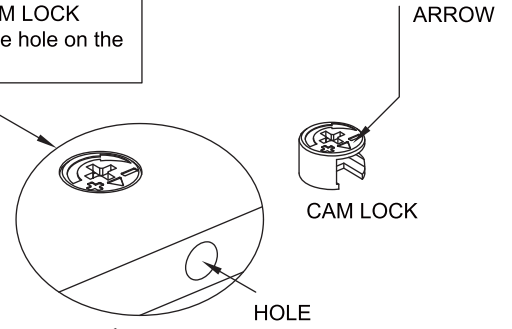
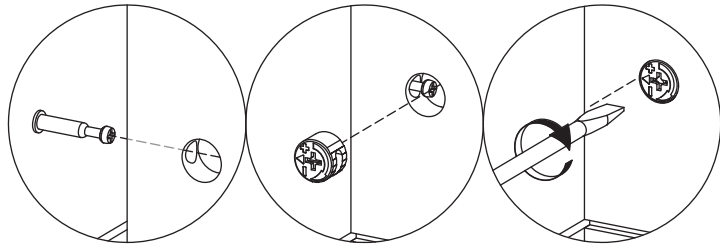

# STEP 4

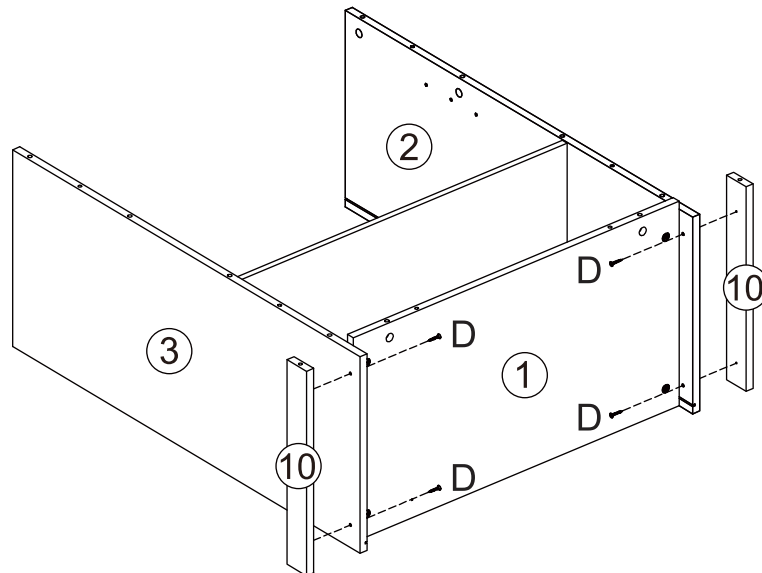
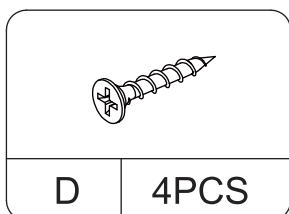

# STEP 5

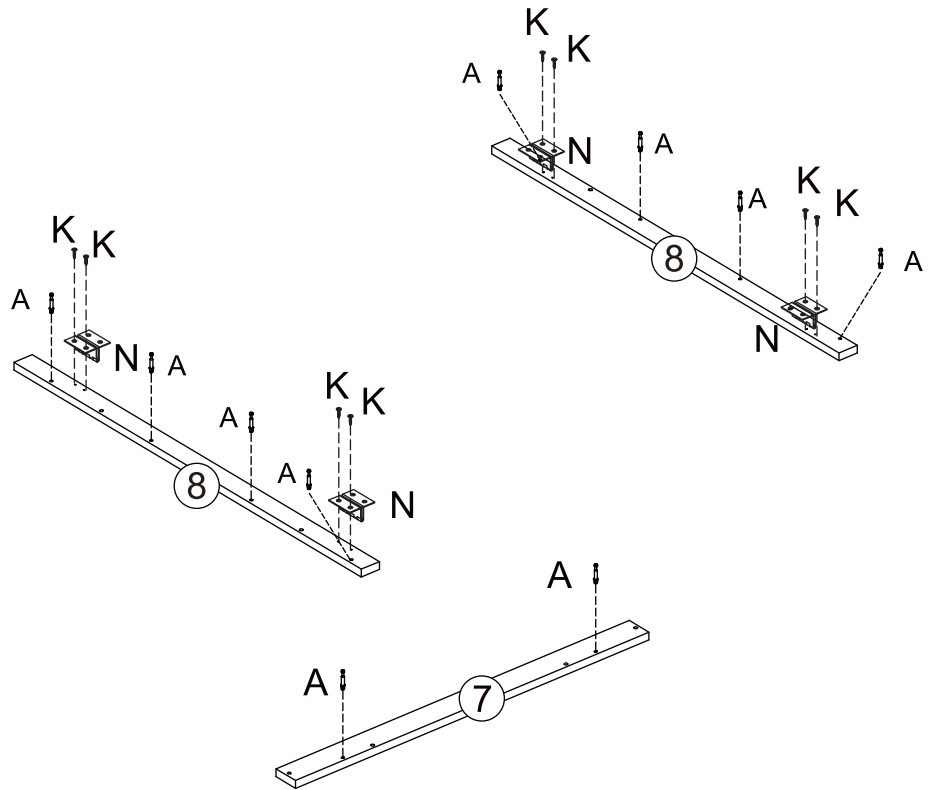
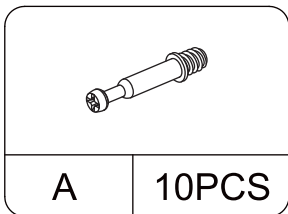
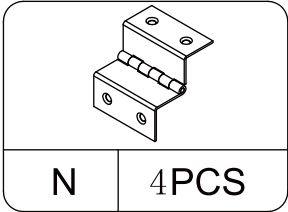
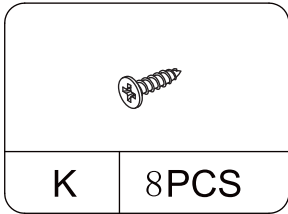

# STEP 6

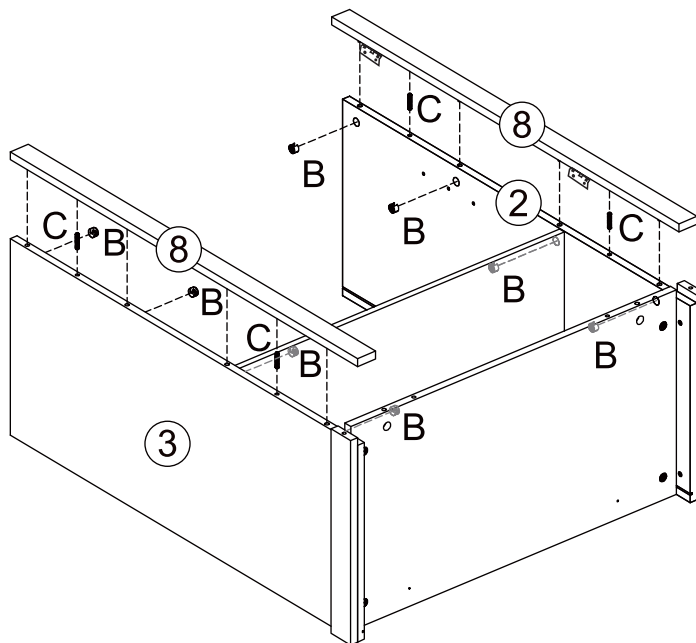
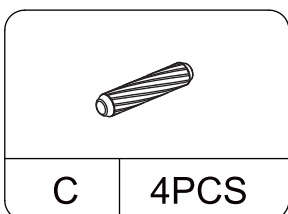
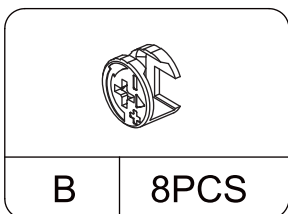

# STEP 7

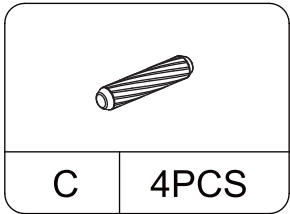
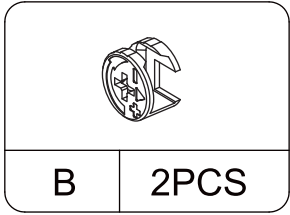
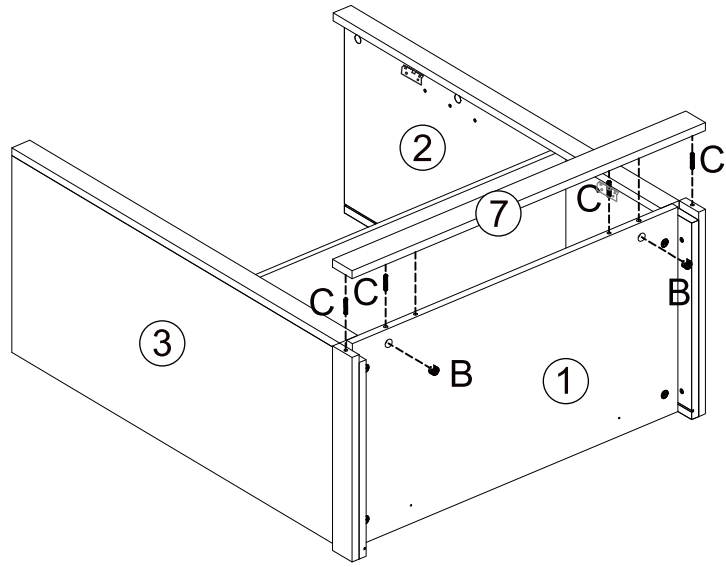

# STEP 8

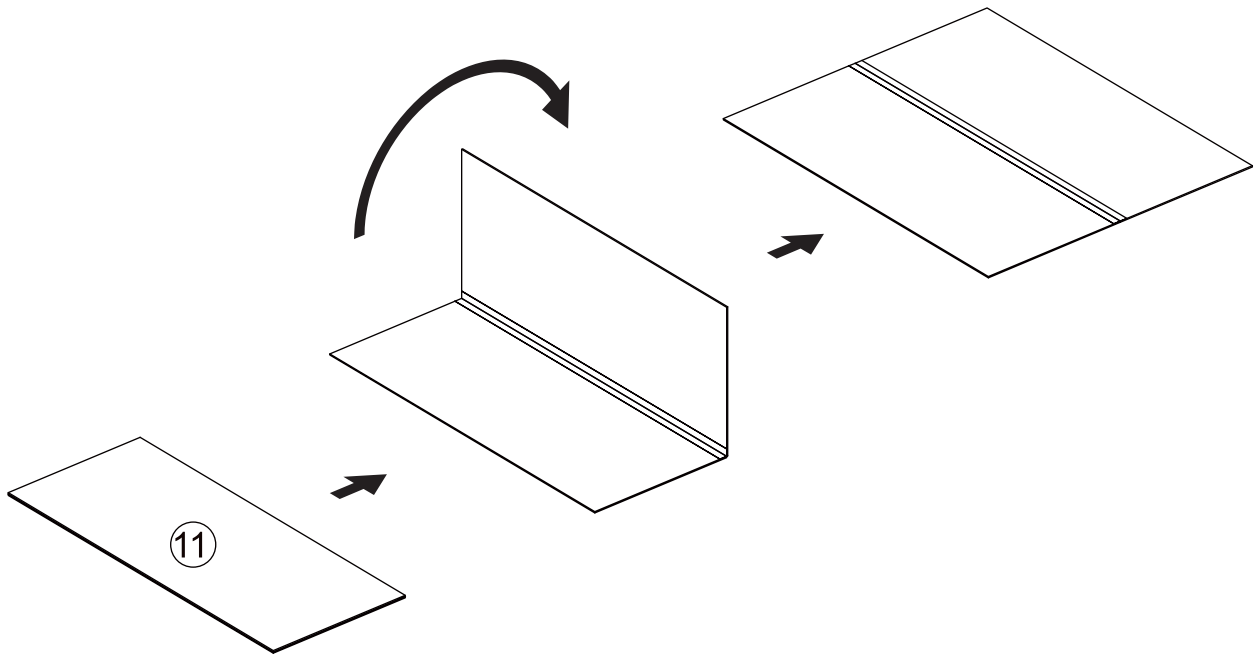

# STEP 9

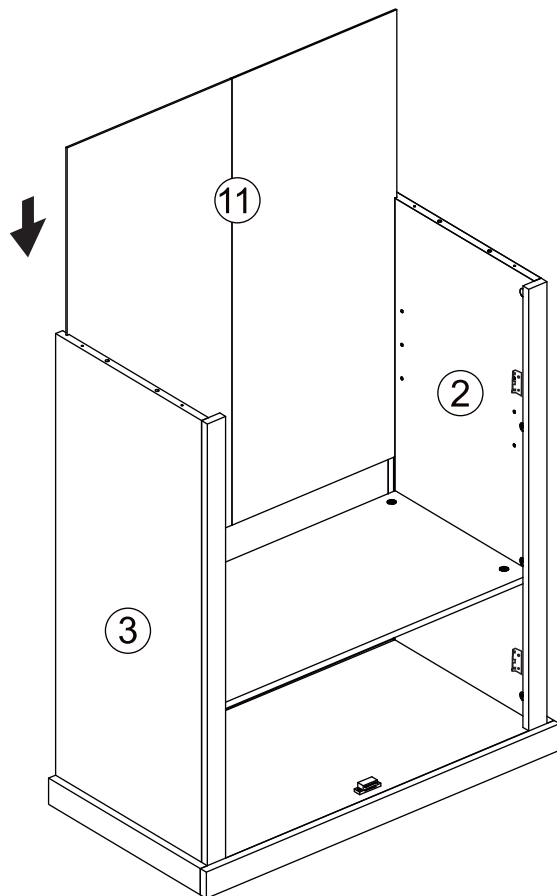

# STEP 10

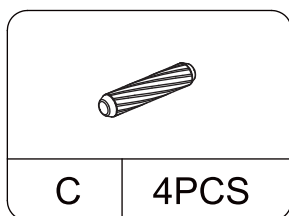
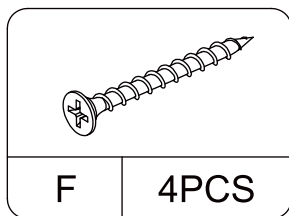
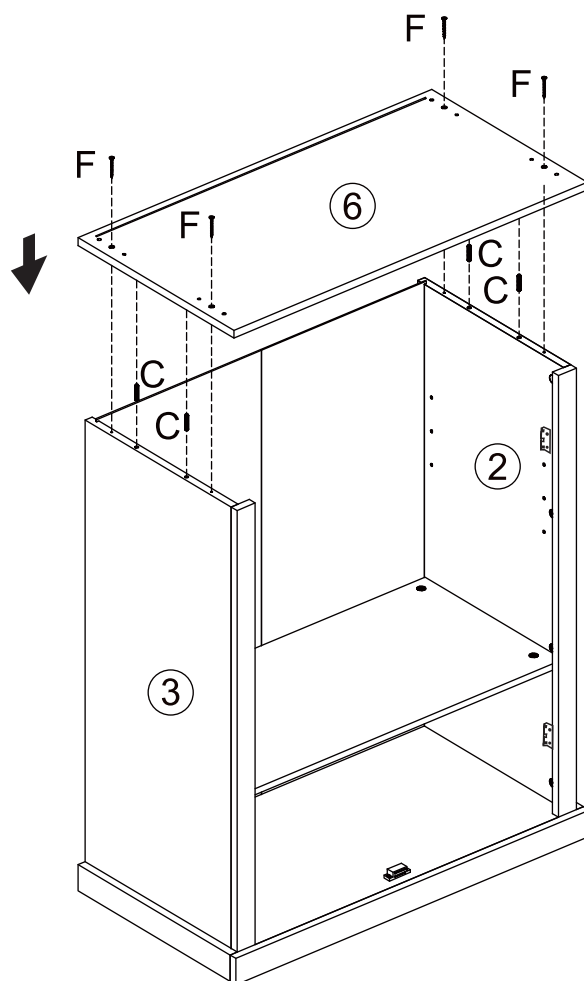

# STEP 11

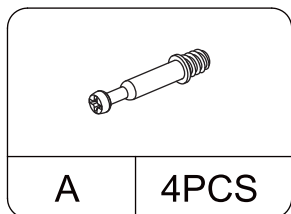
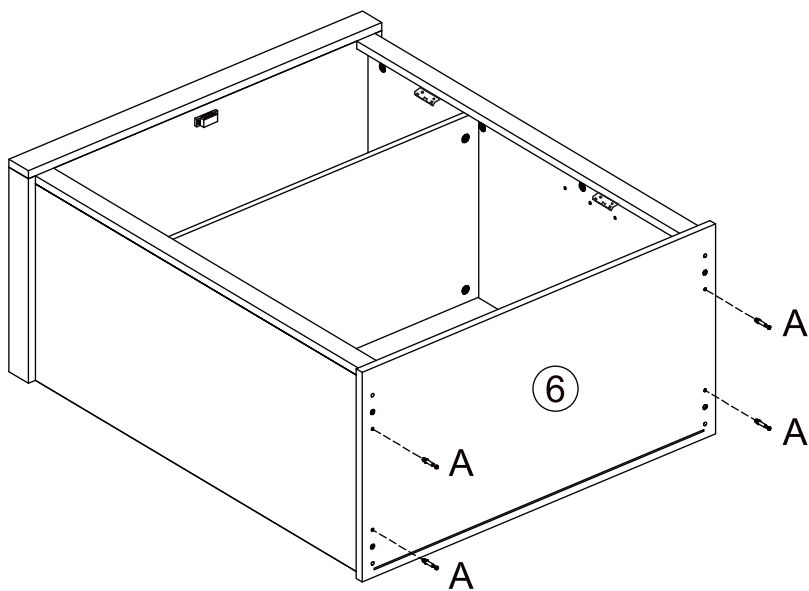

# STEP 12

■ Step 12-22 Install the lower parts

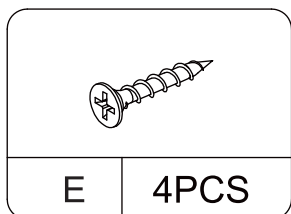
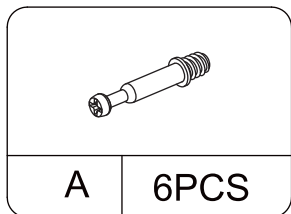
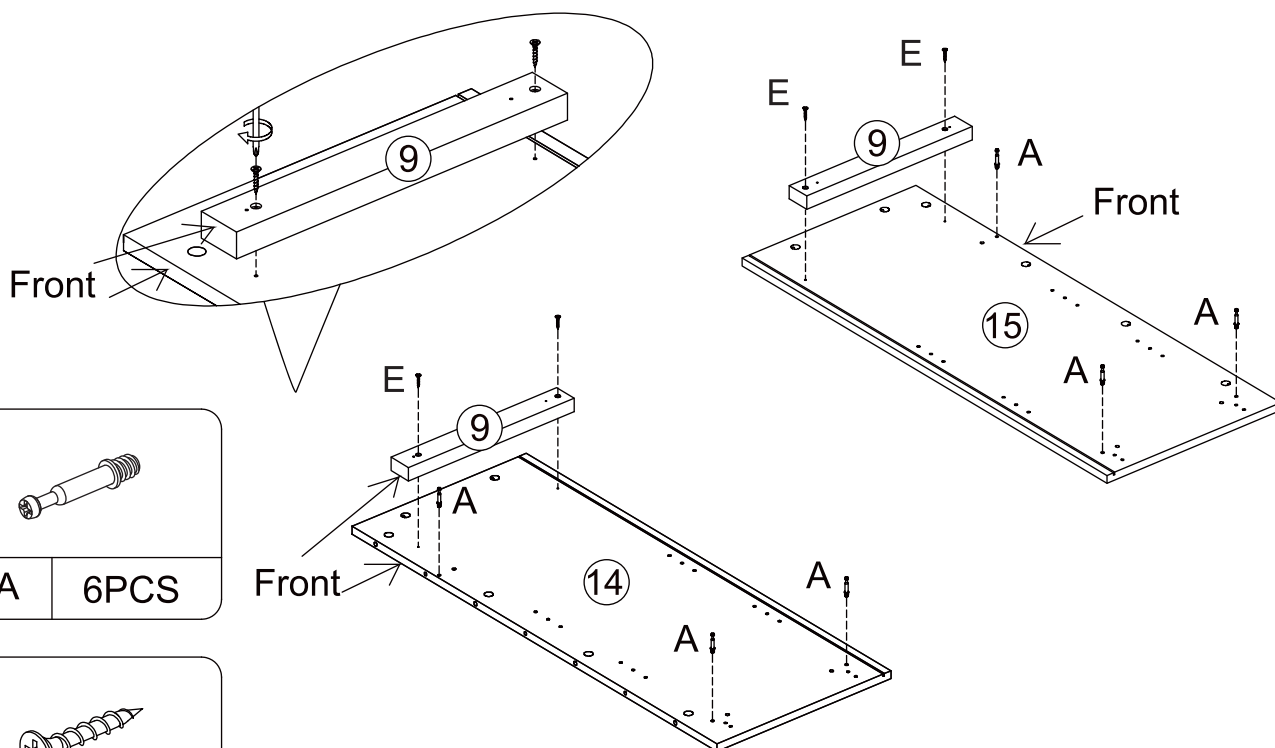

# STEP 13

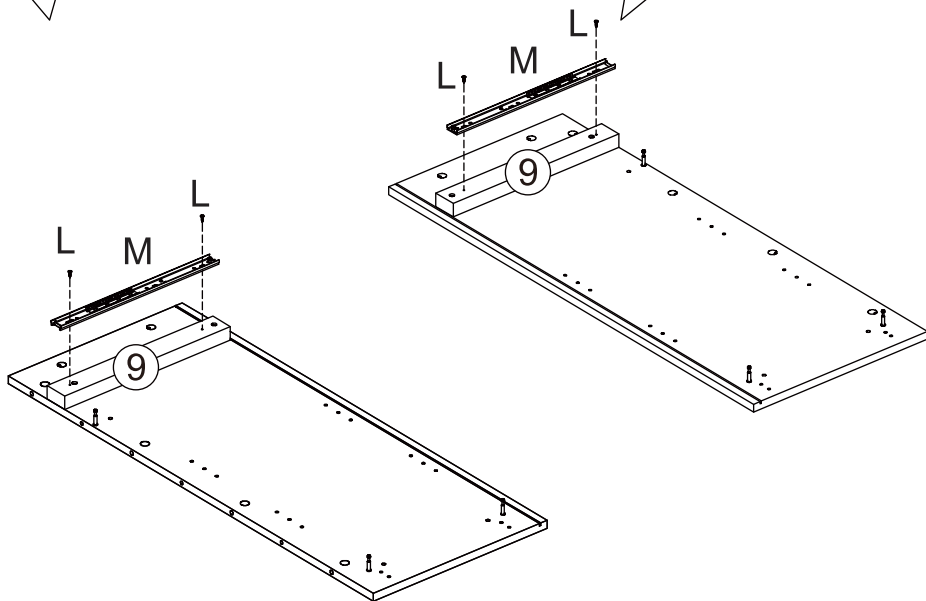
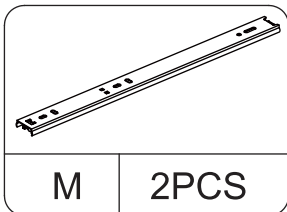
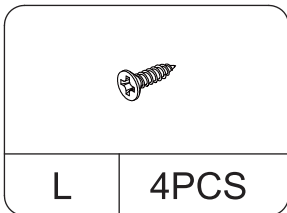
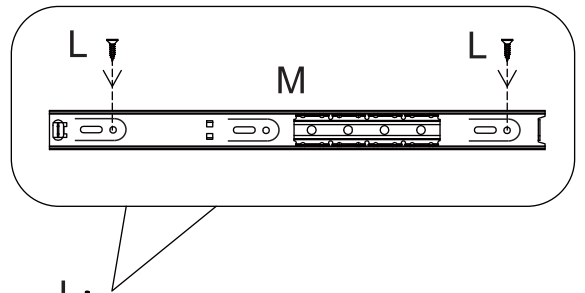
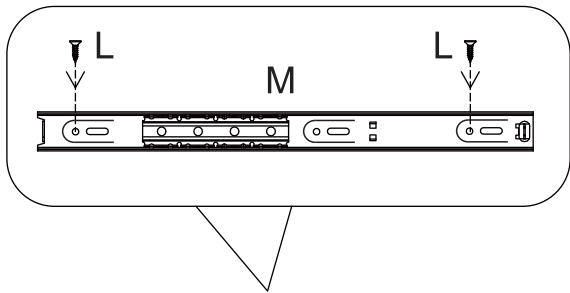
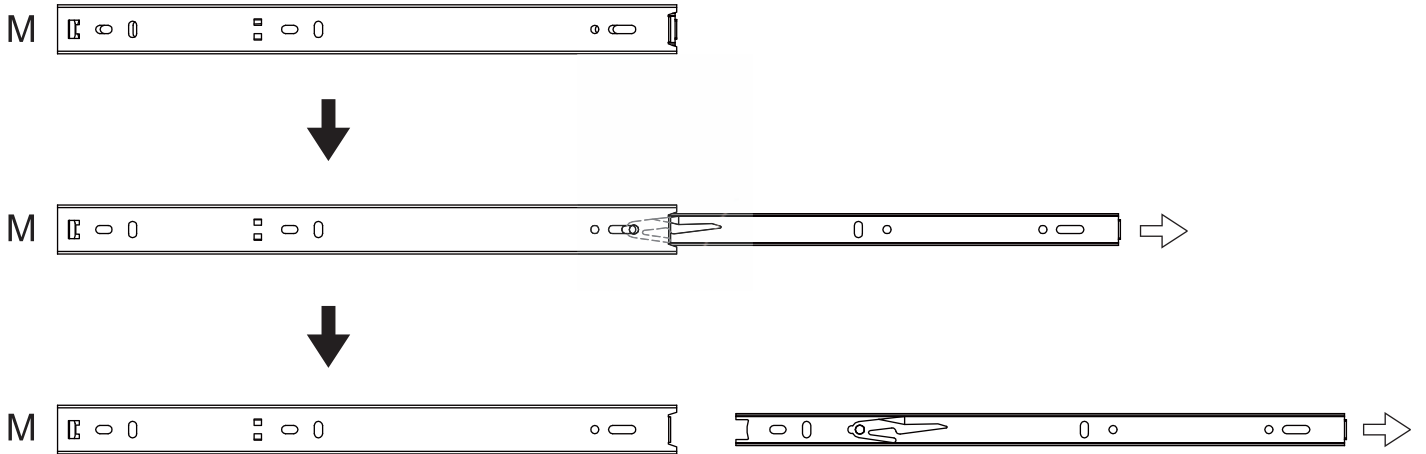

# STEP 14

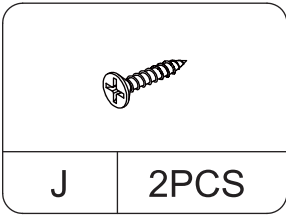
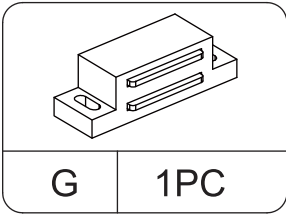
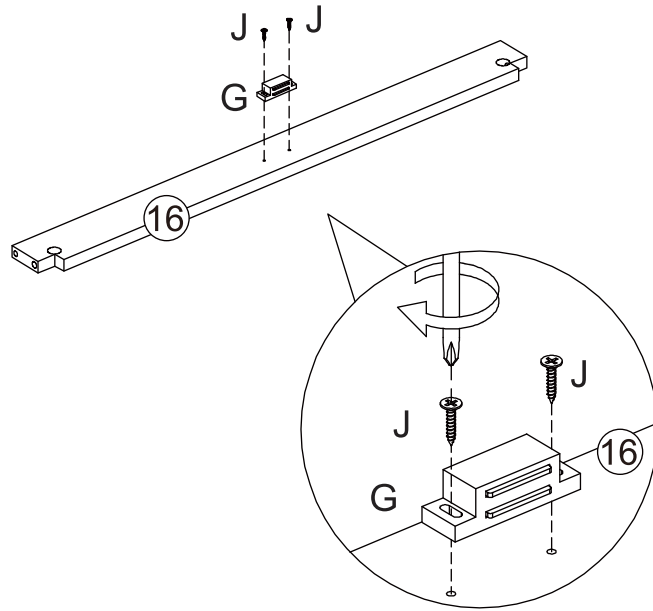

# STEP 15

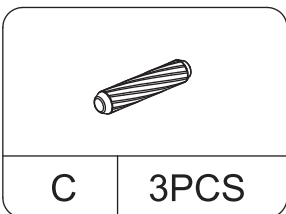
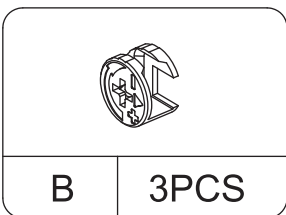
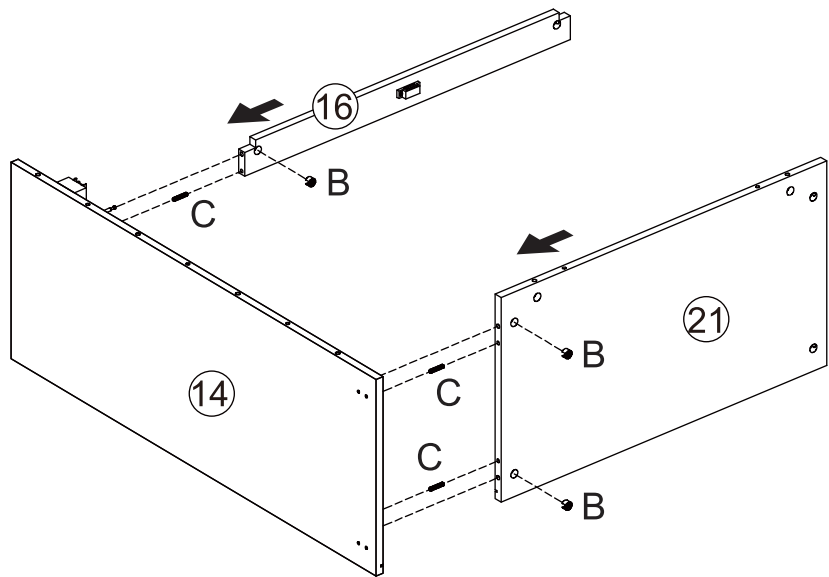

# STEP 16

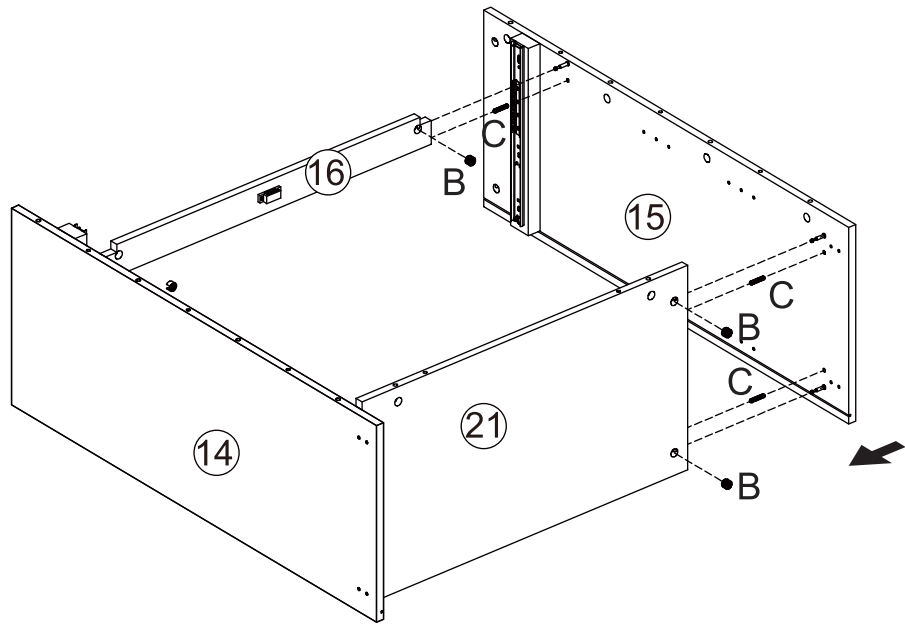

B	3PCS

C	3PCS

# STEP 17

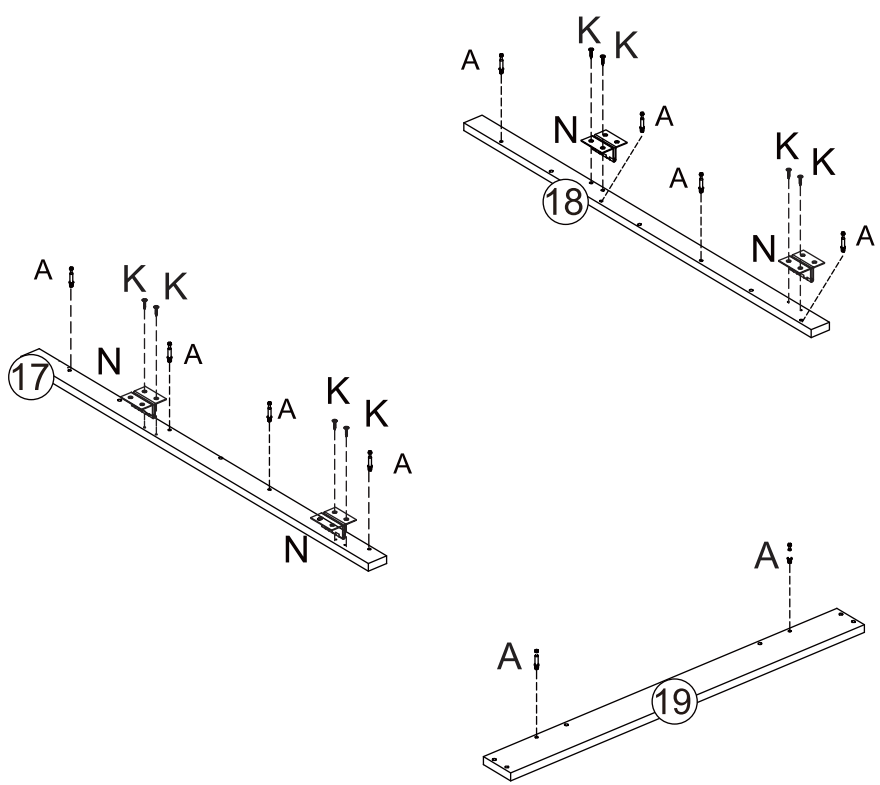

K	8PCS

N	4PCS

A	10PCS

# STEP 18

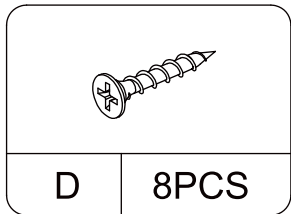
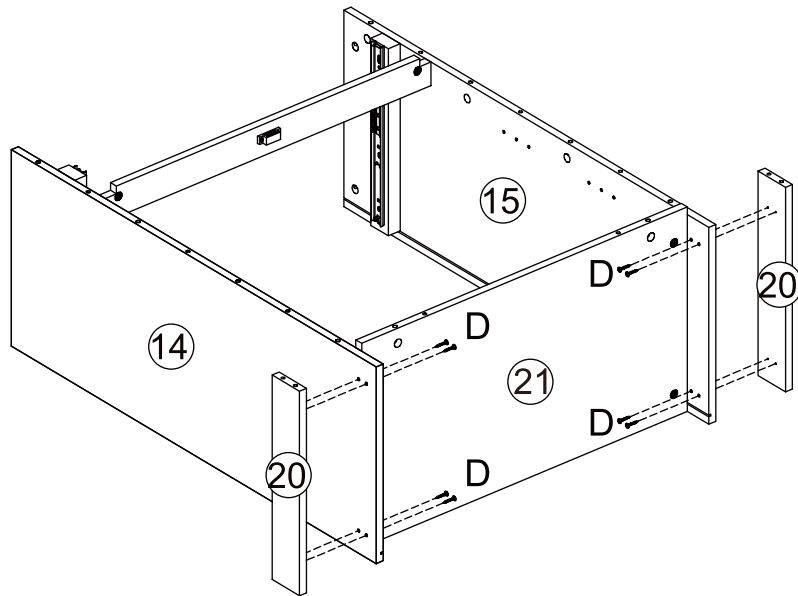

# STEP 19

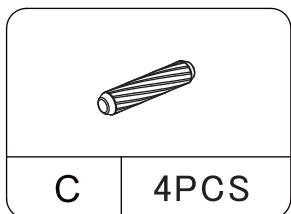
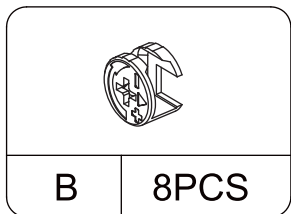
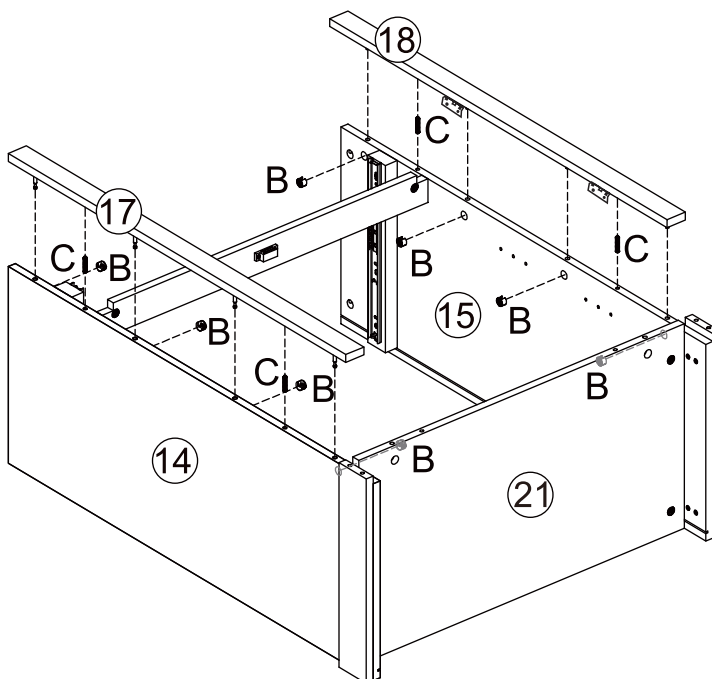

# STEP 20

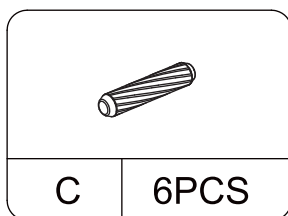
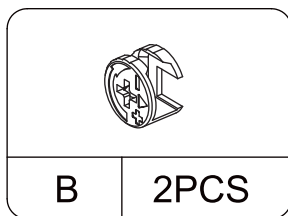
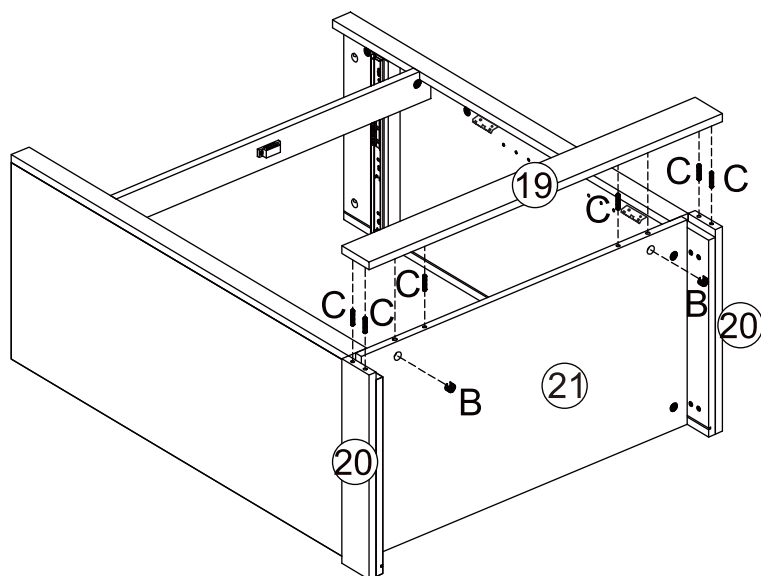

---

# STEP 21

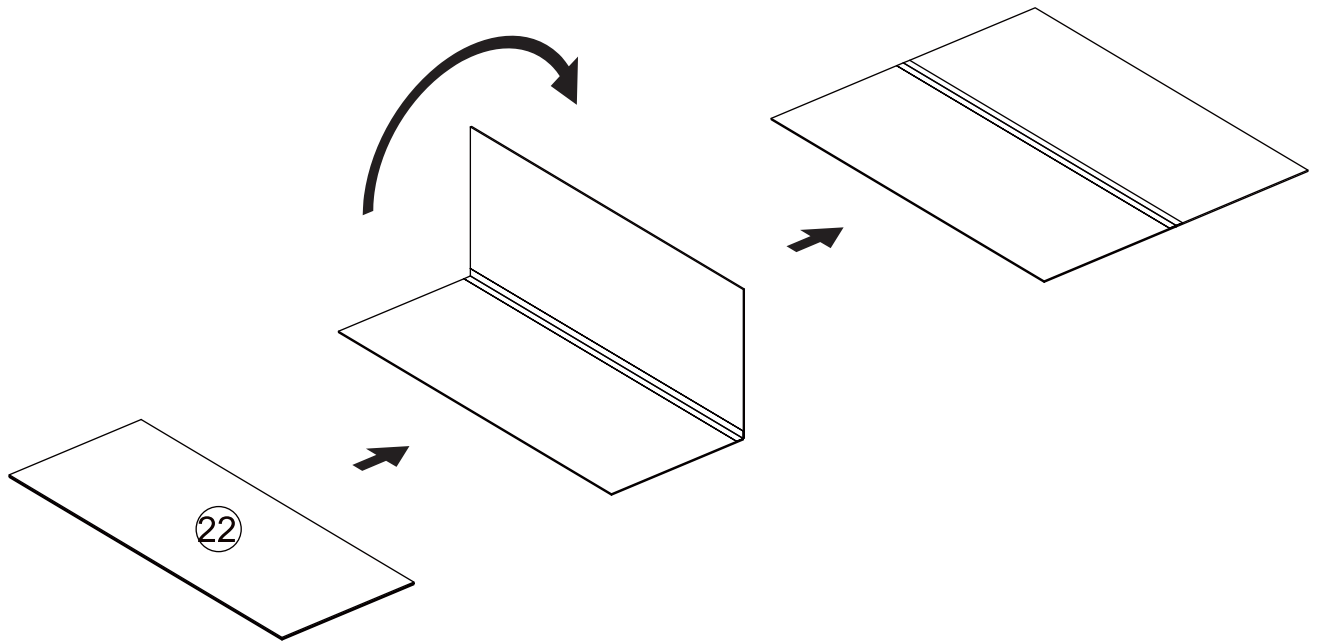

---

# STEP 22

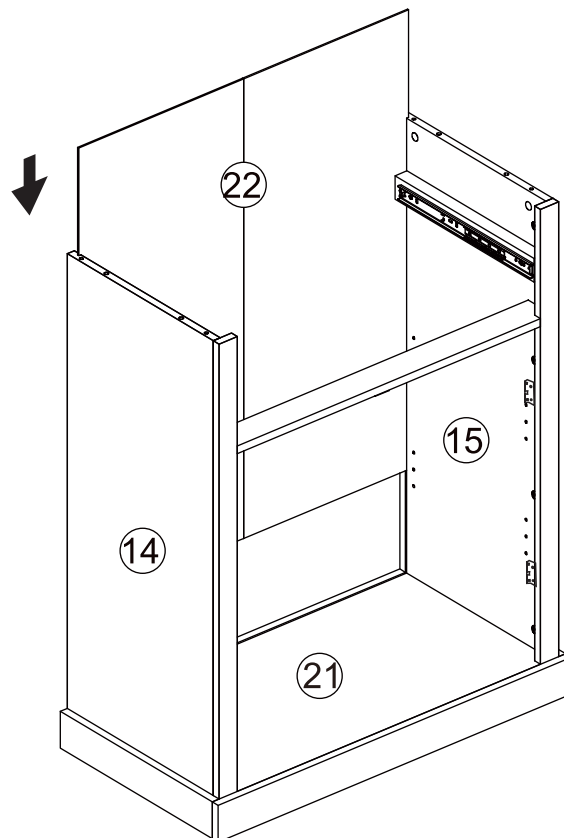

# STEP 23

It needs two customers to hold the upper parts carefully, and then install the upper parts onto the lower parts.

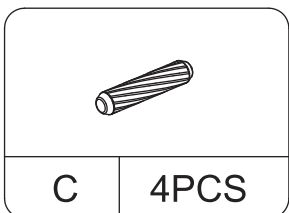
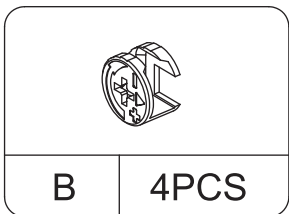
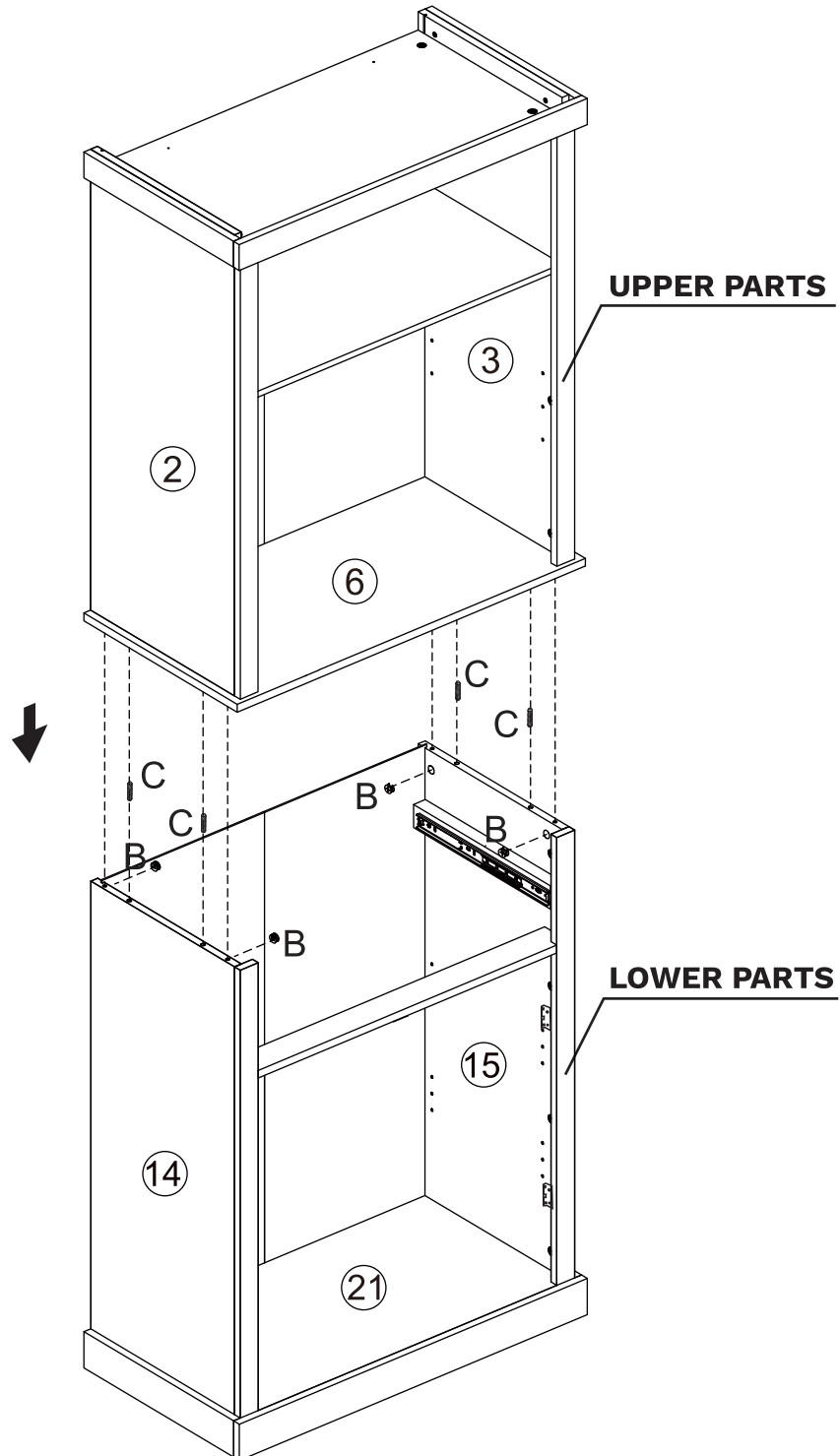

# STEP 24

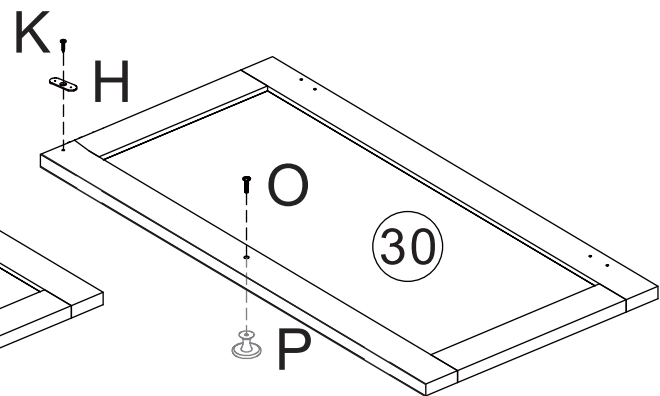
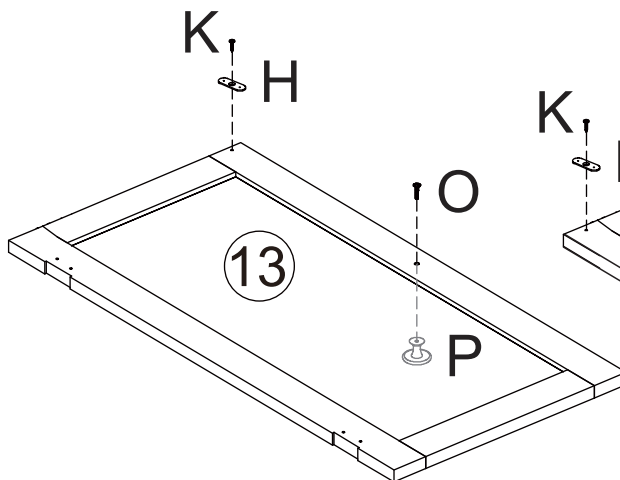
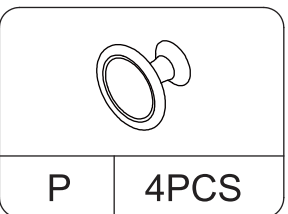
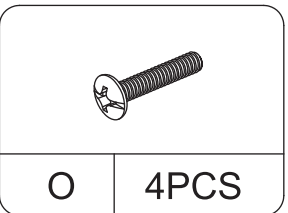
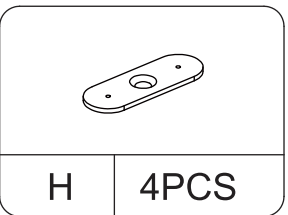
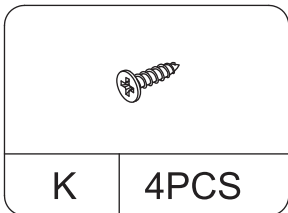
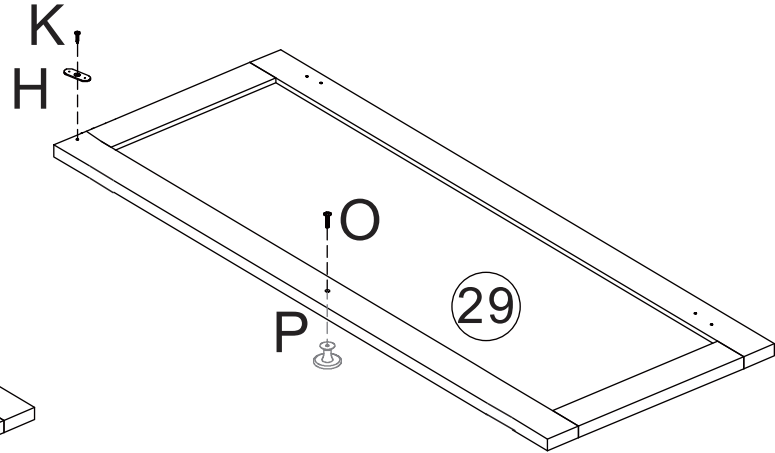
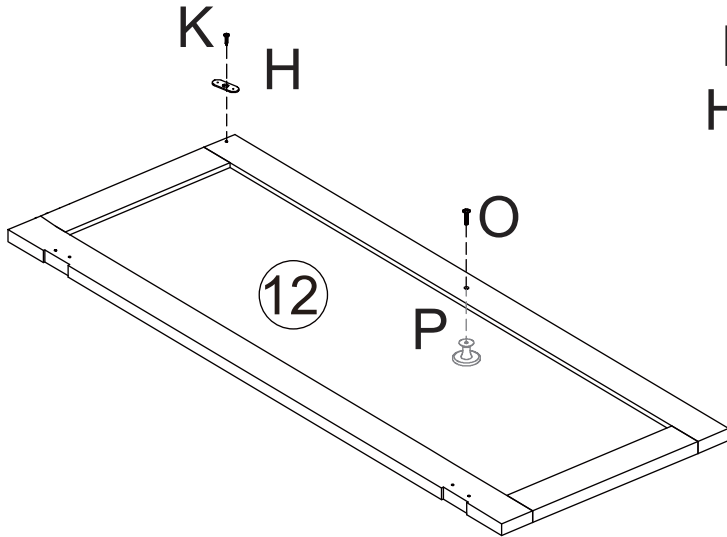

# STEP 25

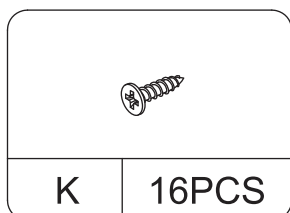
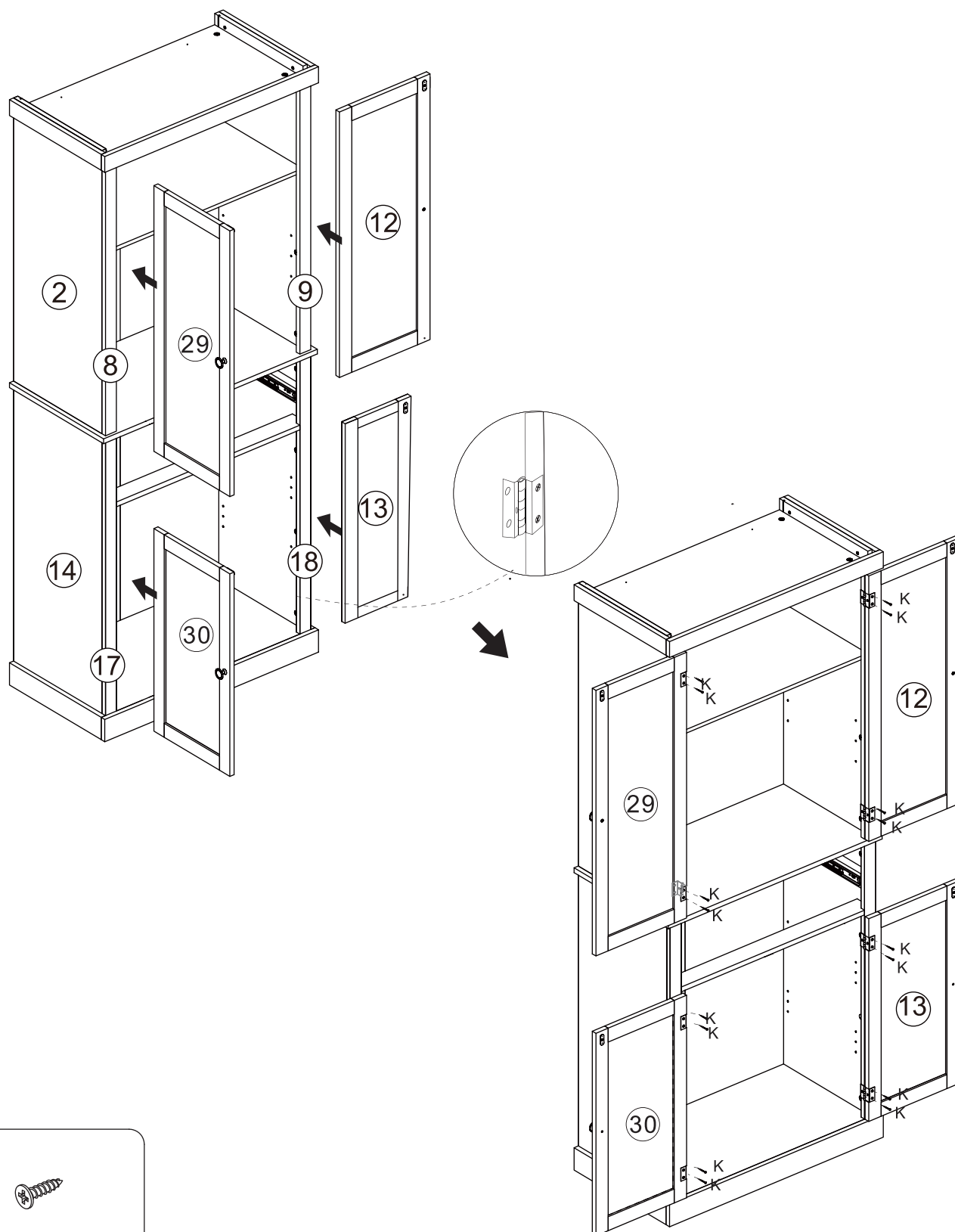

# STEP 26

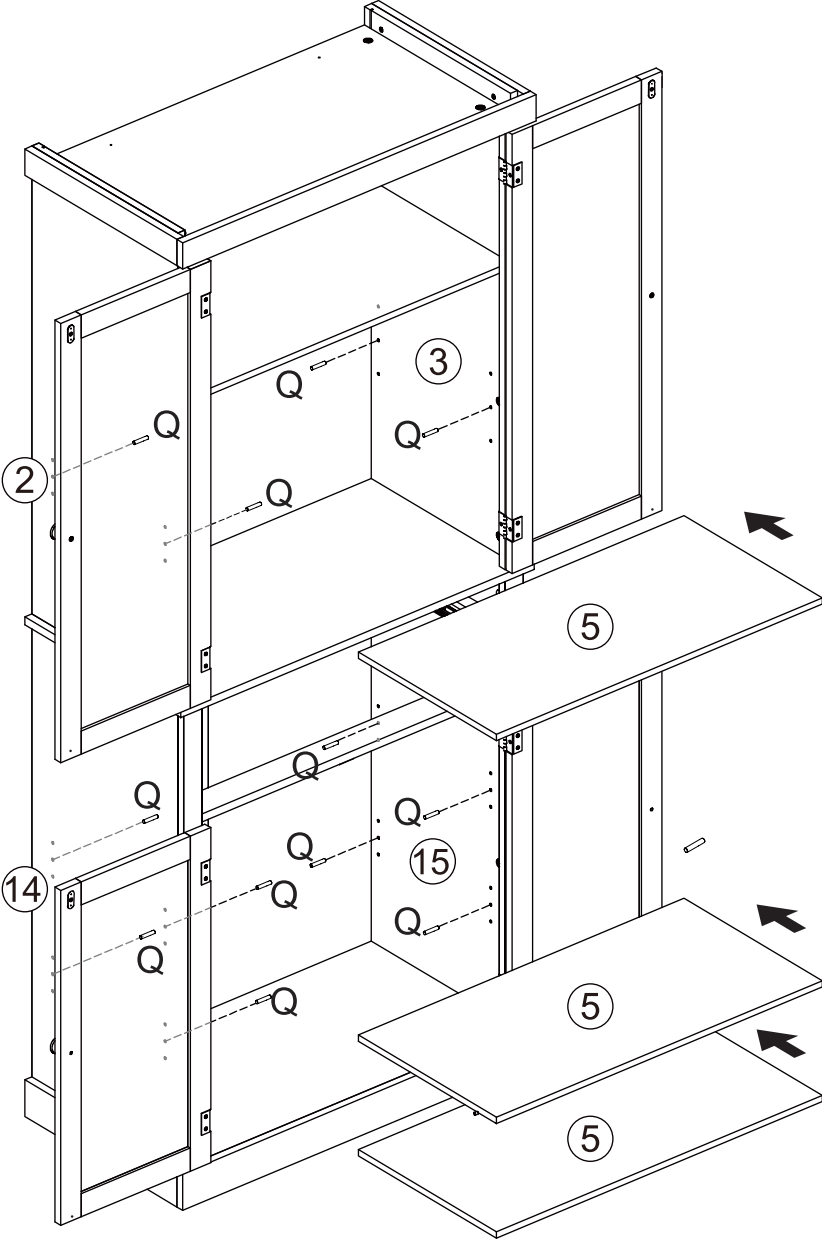

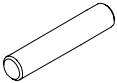
	
Q	12PCS

# STEP 27

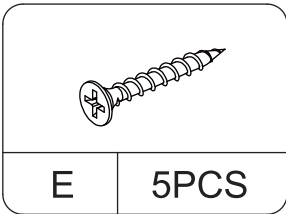
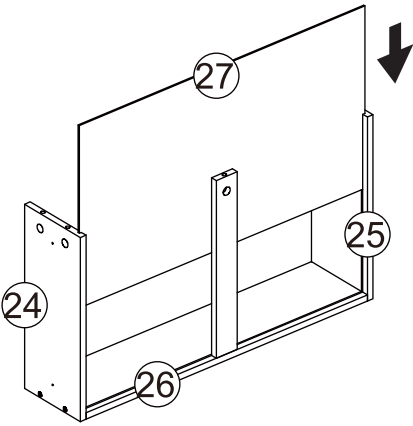
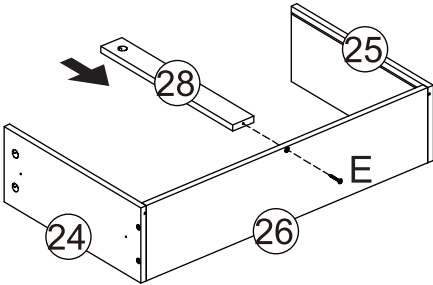
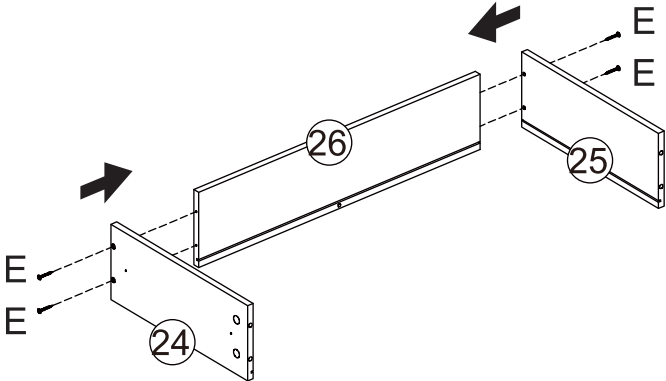

# STEP 28

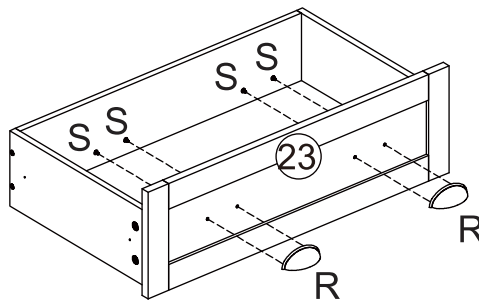
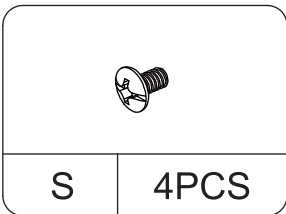
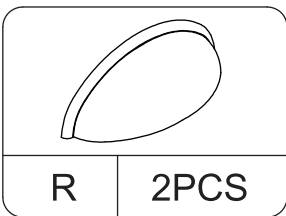
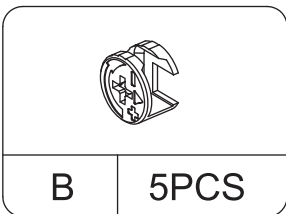
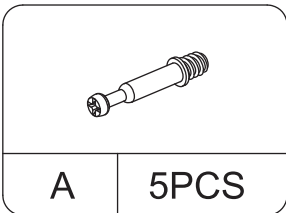
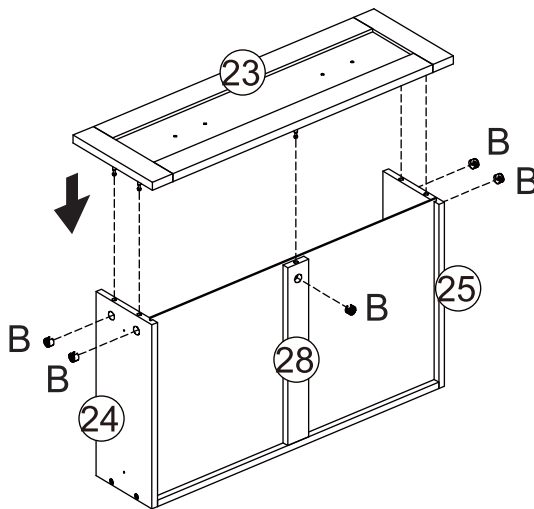
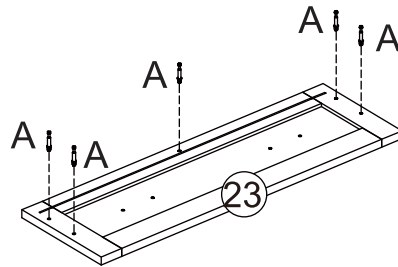

# STEP 29

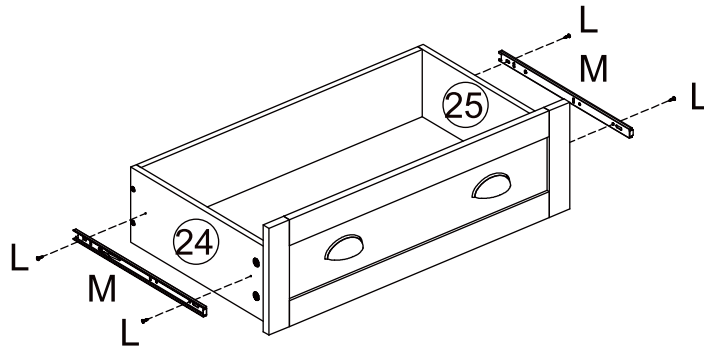
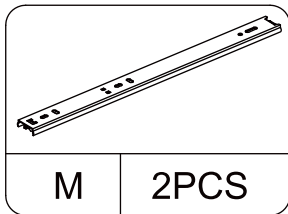
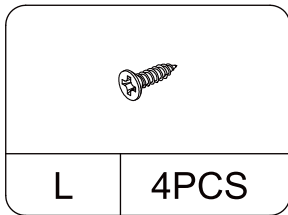
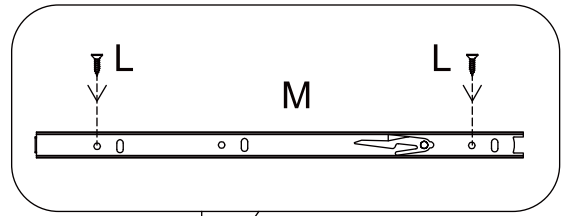
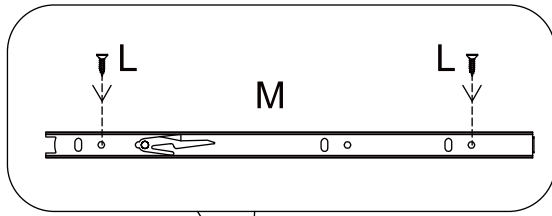

# STEP 30

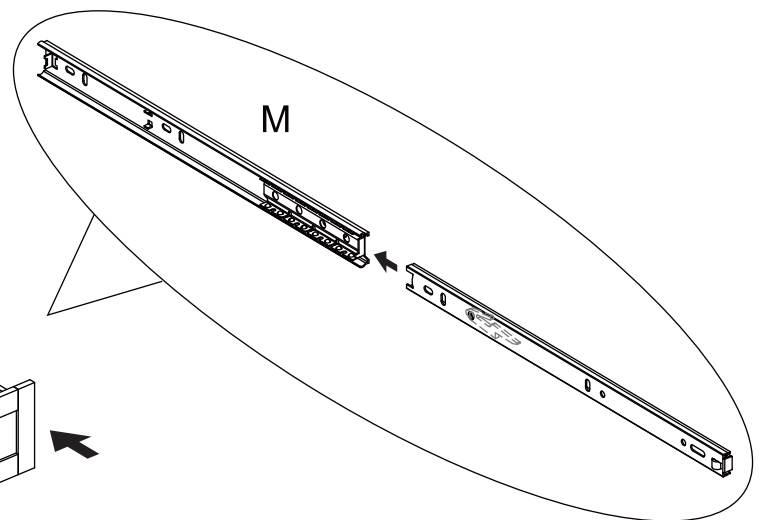
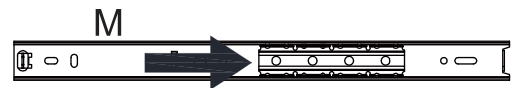
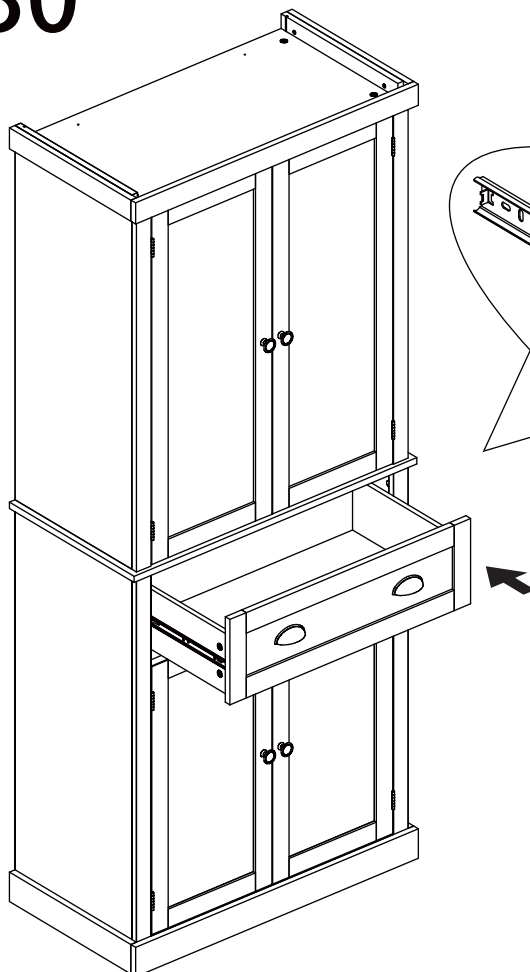

# STEP 31

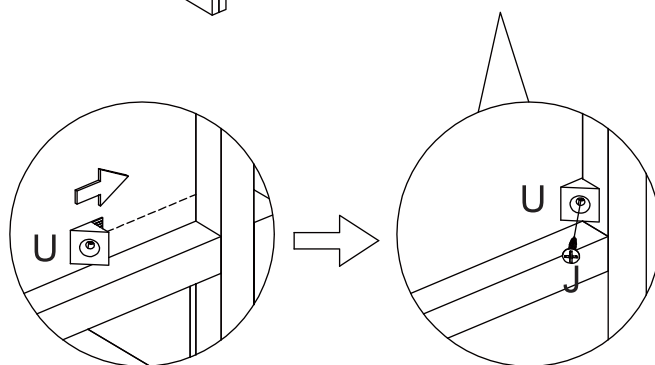
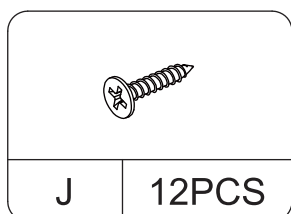
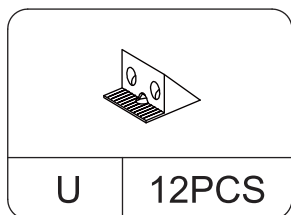
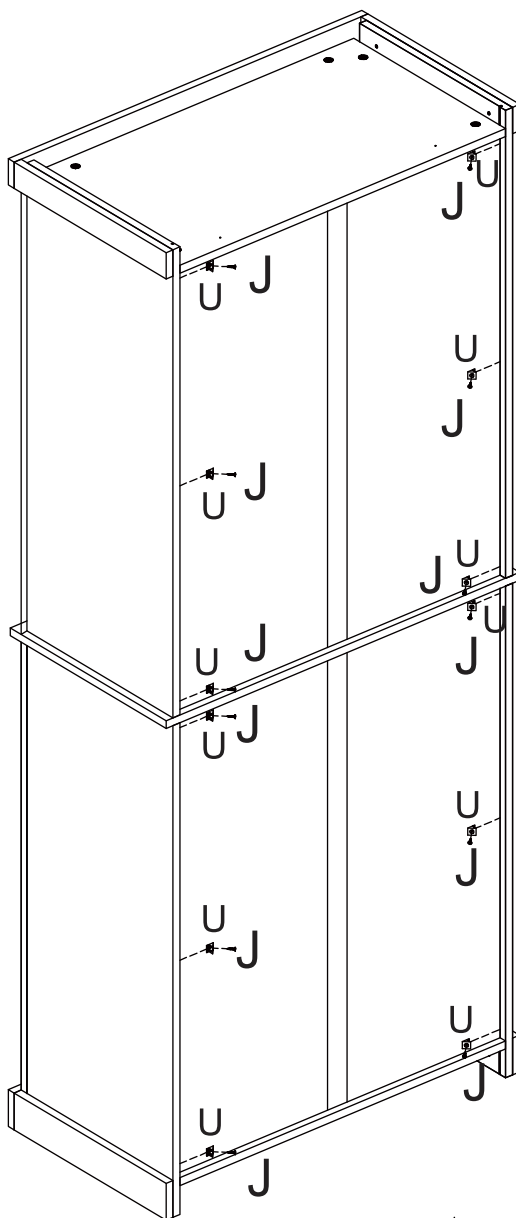

# STEP 32

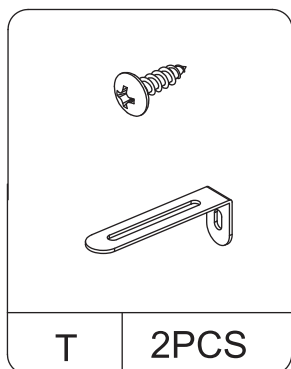
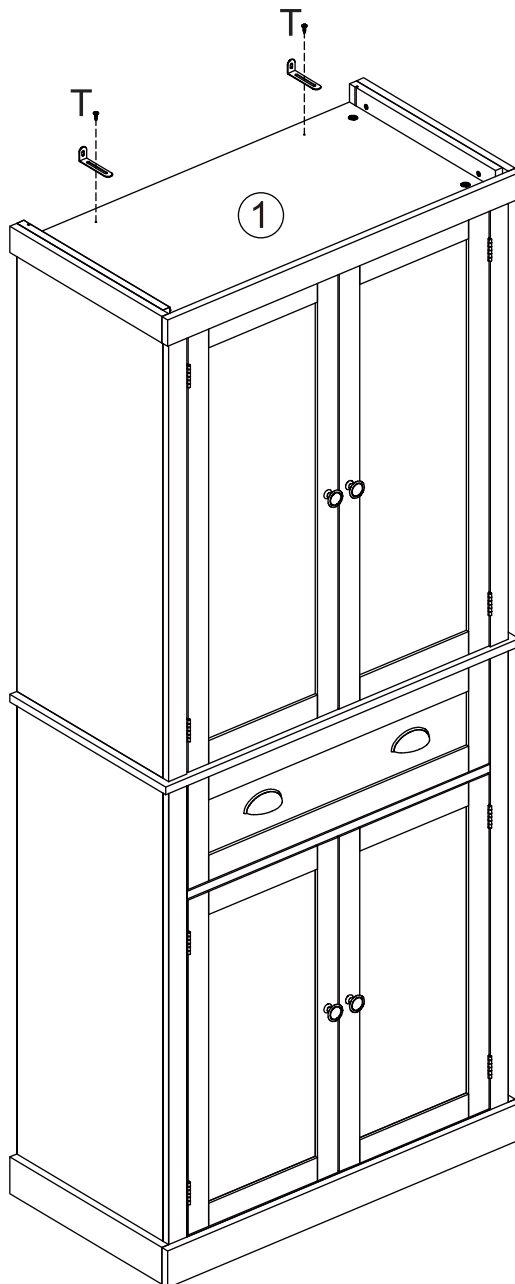

# STEP 33

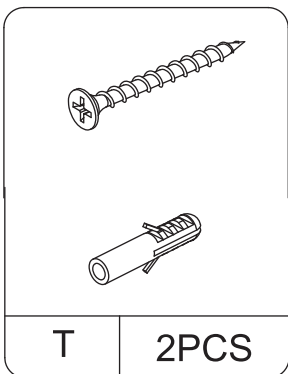
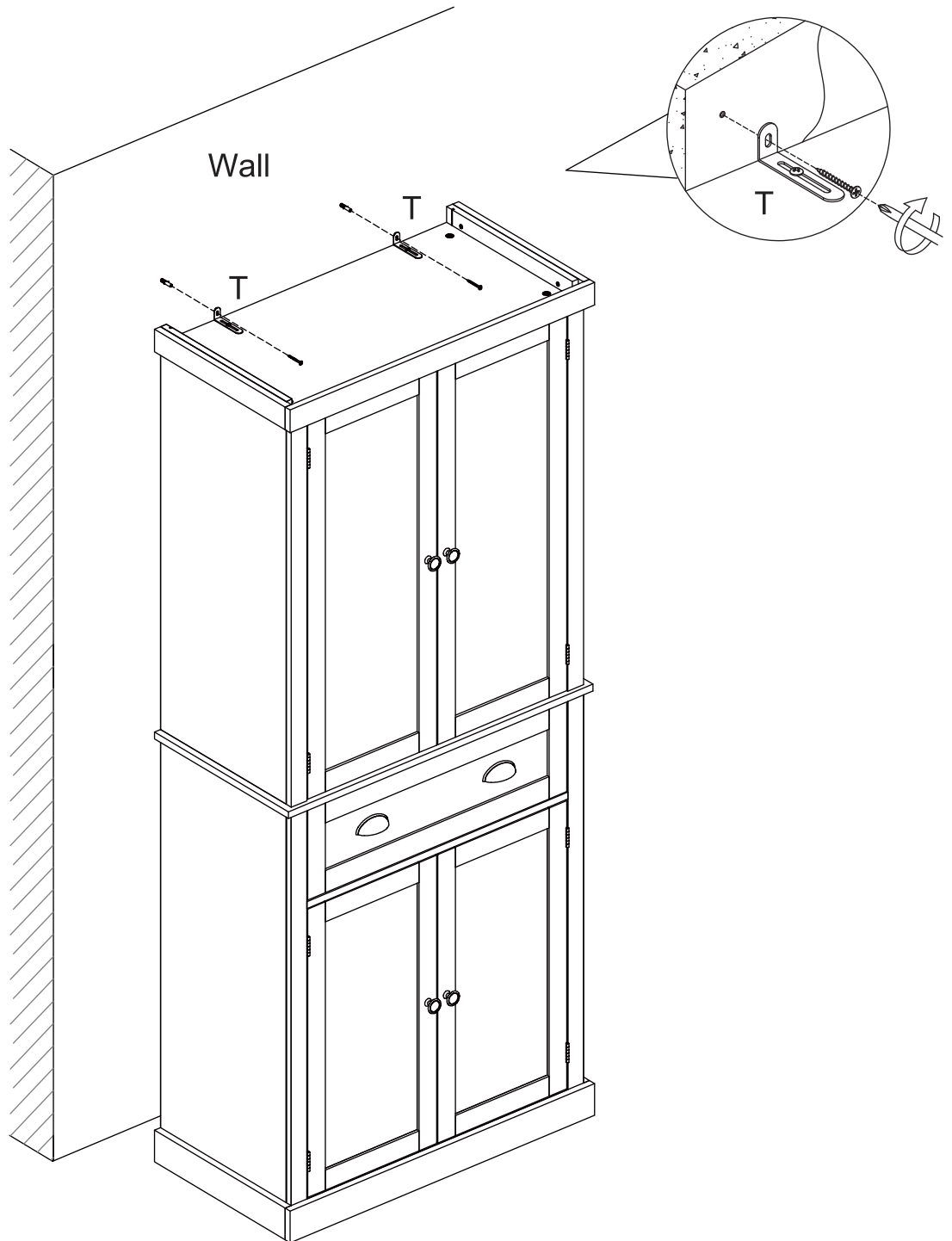
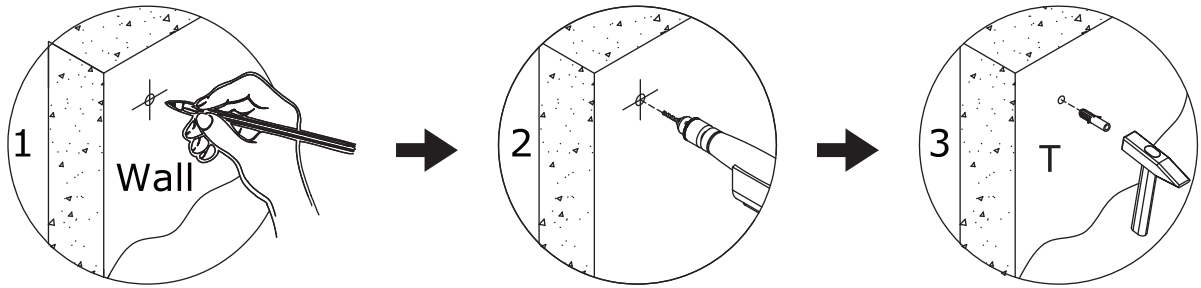

---

# FURNITURE CARE AND MAINTENANCE

## Particleboard

**Thank you for your purchase. We want your item to last as long as possible. To ensure the product gives you years of service, please refer to this care and maintenance guide.**



### MAINTENANCE

- **Tighten all bolts and screws again within the first 2 weeks of assembly**
- **Check the tightness of all bolts every 2 months, tighten them if necessary**

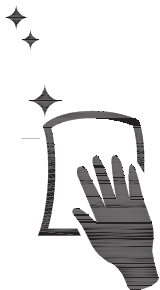

### CLEANING

- **Clean the surface of the PB(Particleboard) with a lightly dampened cloth.**
- **Small amount of mild soap can be used if necessary**
- **Dry the surface immediately after cleaning.**

- ⚠ **DO NOT use bleach or alcohol detergent to clean the surface.**
- ⚠ **DO NOT apply wood treatment on parts made with PB.**

**Particleboard will swell and distort when suffer .  
Make sure to dry the furniture immediately after cleaning**