

# Assembly Instructions

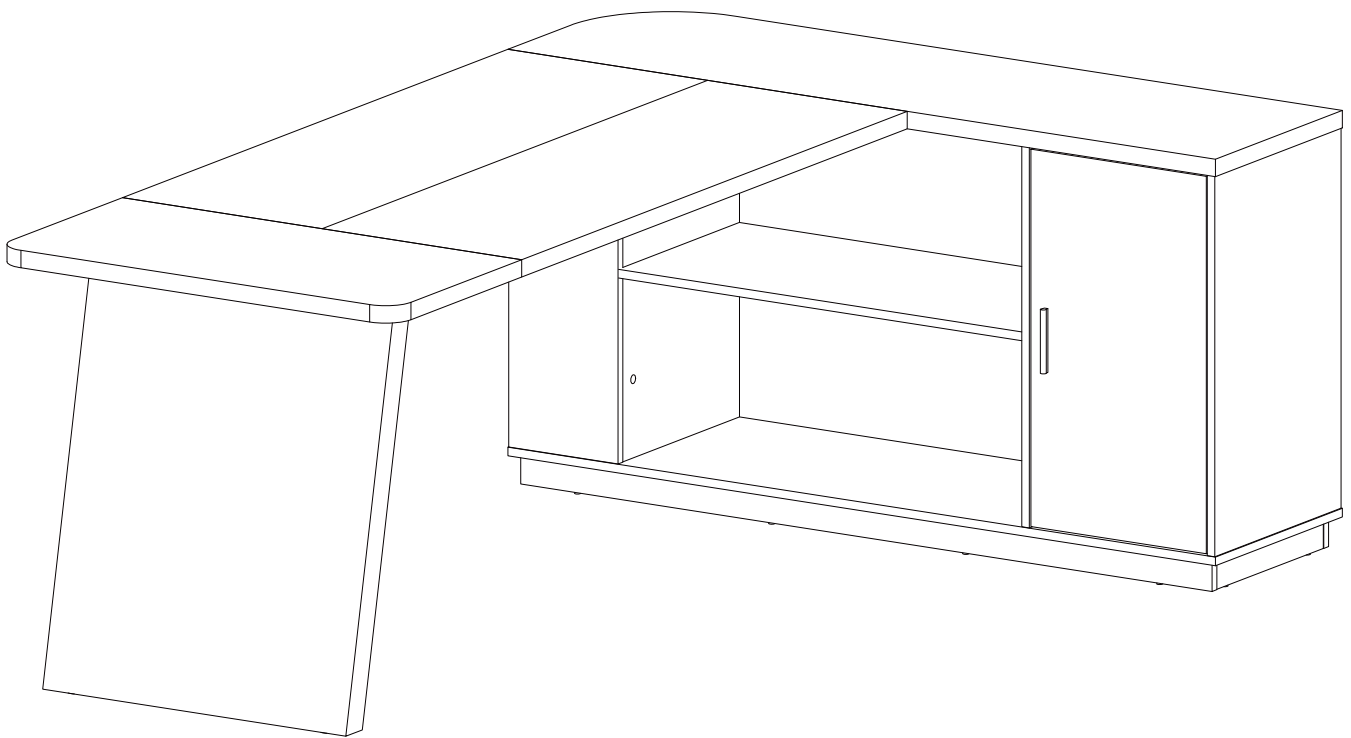

---

**L-Shaped Desk**

Model No.  
**HOGA-F2422-A/B**

---

# Contact Us

## We're here to help you.

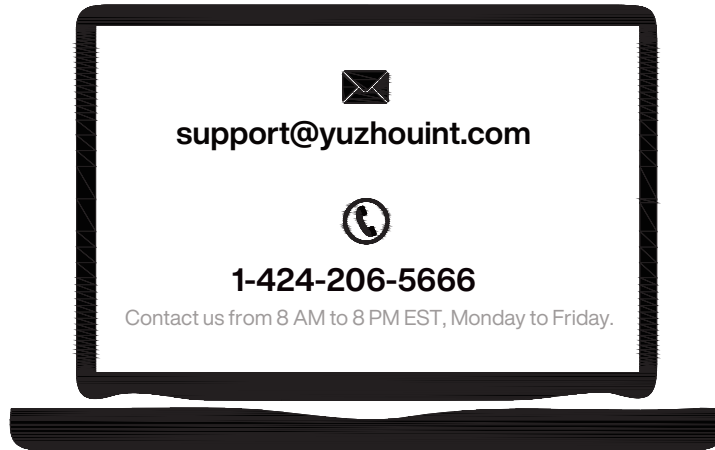

Your satisfaction is our top priority. If you encounter any issues with this product, such as missing or damaged parts, we're here to help. Please retain the original packaging and take photos of the packaging and the product, then contact us as soon as possible.

### Warm Tips

1. Carefully read these instructions and keep them for future reference.
2. Check the parts list and confirm everything's there before starting assembly.
3. When assembling, put all parts on a soft, smooth surface like a carpet to avoid scratches.
4. Don't fully tighten screws until all parts are confirmed in place to avoid misalignment.

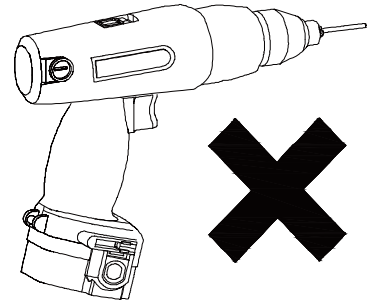
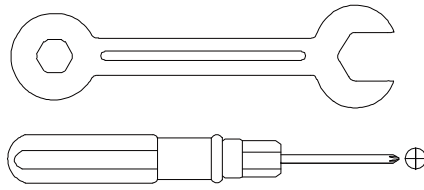
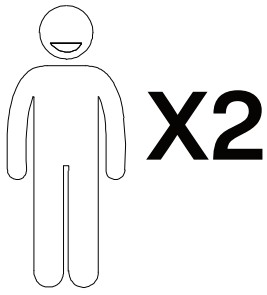

We recommend using hand tools for assembly.

If an electric screwdriver is used, reduce power and torque to avoid damage to the product.

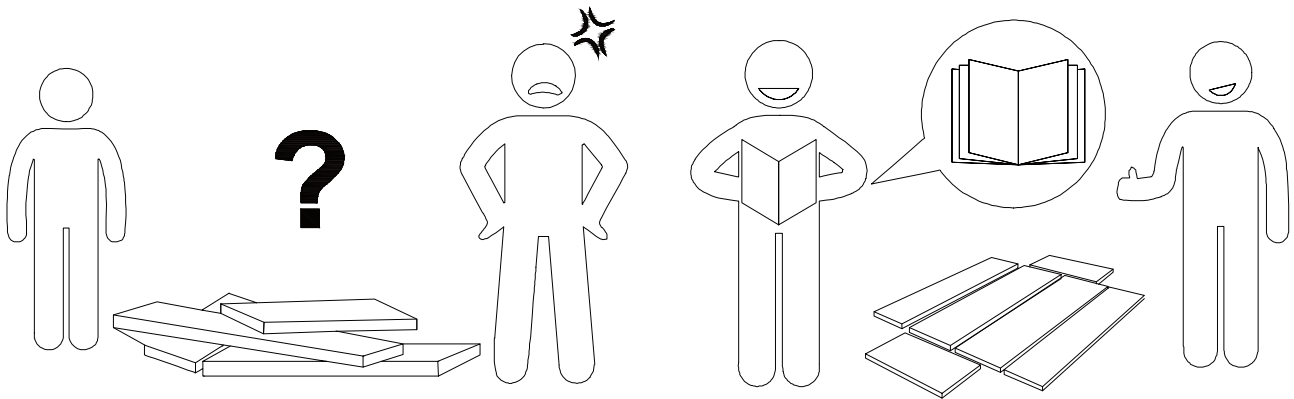

## AVOID SCRATCHES

In order to avoid scratching, this furniture should be assembled on a soft surface, such as a rug.

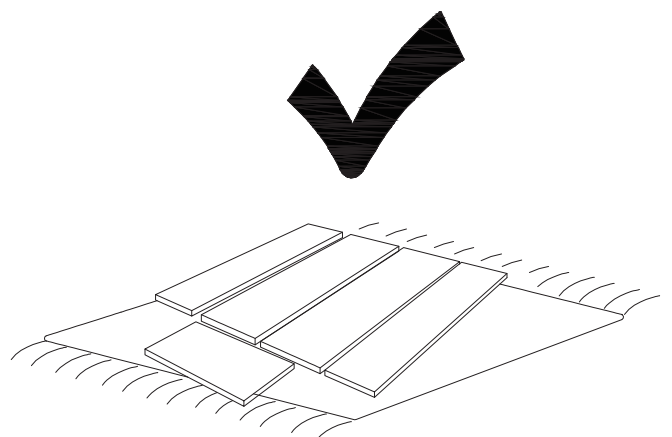
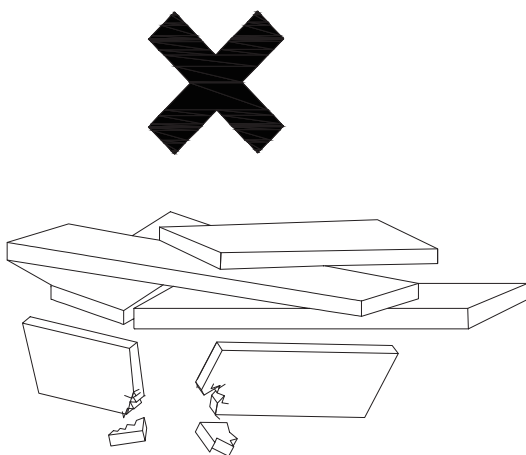

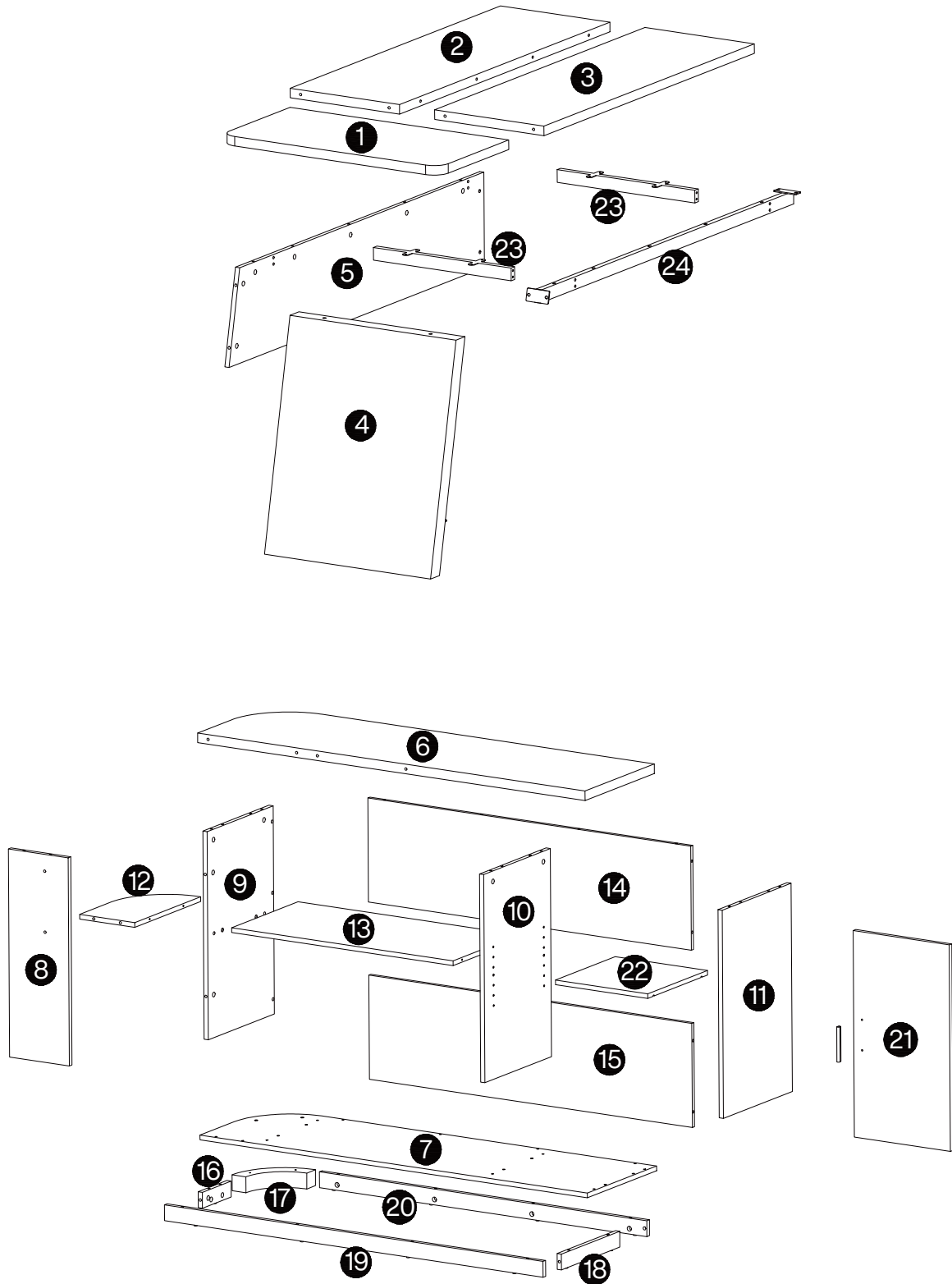







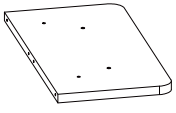
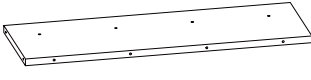
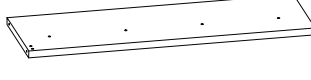
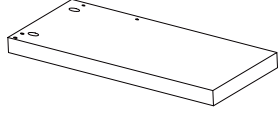
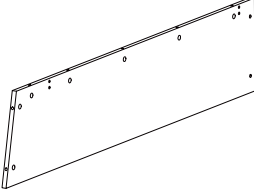
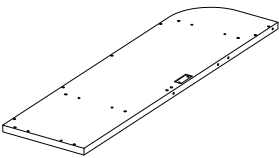
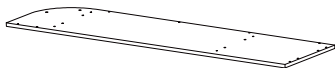
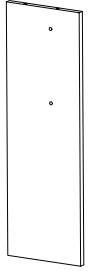
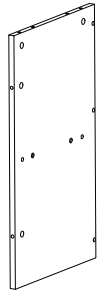
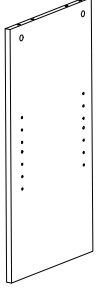
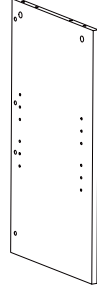
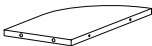

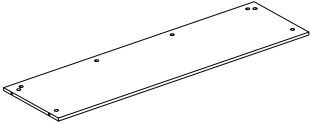
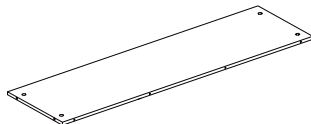

**⚠ Caution**

Make sure all parts are included. Most board parts are labeled or stamped on the raw edge. Contact us for a free replacement if you encounter any damaged or missing parts.

# Parts List

<p>1</p>  <p>1pc</p>	<p>2</p>  <p>1pc</p>	<p>3</p>  <p>1pc</p>	<p>4</p>  <p>1pc</p>
<p>5</p>  <p>1pc</p>	<p>6</p>  <p>1pc</p>	<p>7</p>  <p>1pc</p>	<p>8</p>  <p>1pc</p>
<p>9</p>  <p>1pc</p>	<p>10</p>  <p>1pc</p>	<p>11</p>  <p>1pc</p>	<p>12</p>  <p>1pc</p>
<p>13</p>  <p>1pc</p>	<p>14</p>  <p>1pc</p>	<p>15</p>  <p>1pc</p>	<p>16</p>  <p>1pc</p>
<p>17</p>  <p>1pc</p>	<p>18</p>  <p>1pc</p>	<p>19</p>  <p>1pc</p>	<p>20</p>  <p>1pc</p>

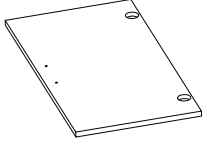
# Parts List

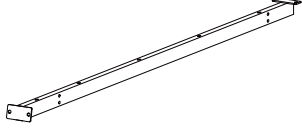
<p>21</p>  <p>1 pc</p>	<p>22</p>  <p>1 pc</p>	<p>23</p>  <p>2 pcs</p>	<p>24</p>  <p>1 pc</p>
---	---	---	---

Before installation, please check if you have received the A, B and C packages, and check if the parts are complete.



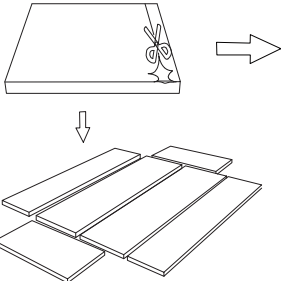

HOGA-F2422-A			
2	1 pc	15	1 pc
3	1 pc	16	1 pc
5	1 pc	19	1 pc
6	1 pc	20	1 pc
7	1 pc	21	1 pc
12	1 pc	22	1 pc
14	1 pc	24	1 pc

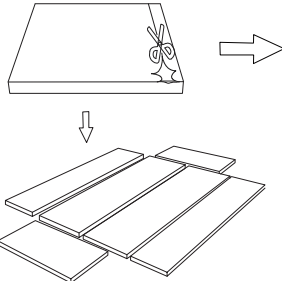



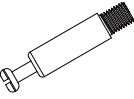
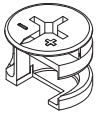
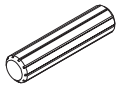





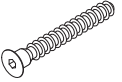



HOGA-F2422-B			
1	1 pc	17	1 pc
4	1 pc	18	1 pc
8	1 pc	23	2 pcs
9	1 pc		
10	1 pc		
11	1 pc		
13	1 pc		



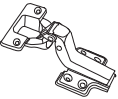

# Hardware List

A	B	C	D	E	F	G
						
M6x40mm	Ø15x10mm	Ø8x35mm	M6x55mm	M6x40mm	M6x15mm	M6x12mm
48 pcs	48 pcs	24 pcs	5 pcs	8 pcs	4 pcs	4 pcs

H	I	J	K	L	M	N
						
ST6x40mm	Ø35	M8x70mm	M8	M8		ST3.5x14mm
18 pcs	2 pcs	2 pcs	2 pcs	2 pcs	2 pcs	64 pcs

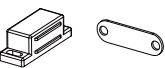
O	P	Q	R	S	T	U
						
		M6	M4x18mm			
2 pcs	4 pcs	2 pcs	2 pcs	1 pc	1 pc	5 pcs

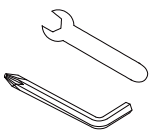
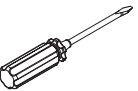
V	W	X	Y	Z
				
		M6x50mm		
24 pcs	1 pc	2 pcs	1 pc	1 pc

# Installation of Cams and Pins

Read each step carefully before starting. Each step of instruction should be performed in the correct order. If these steps are not followed in sequence, assembly difficulties may occur.

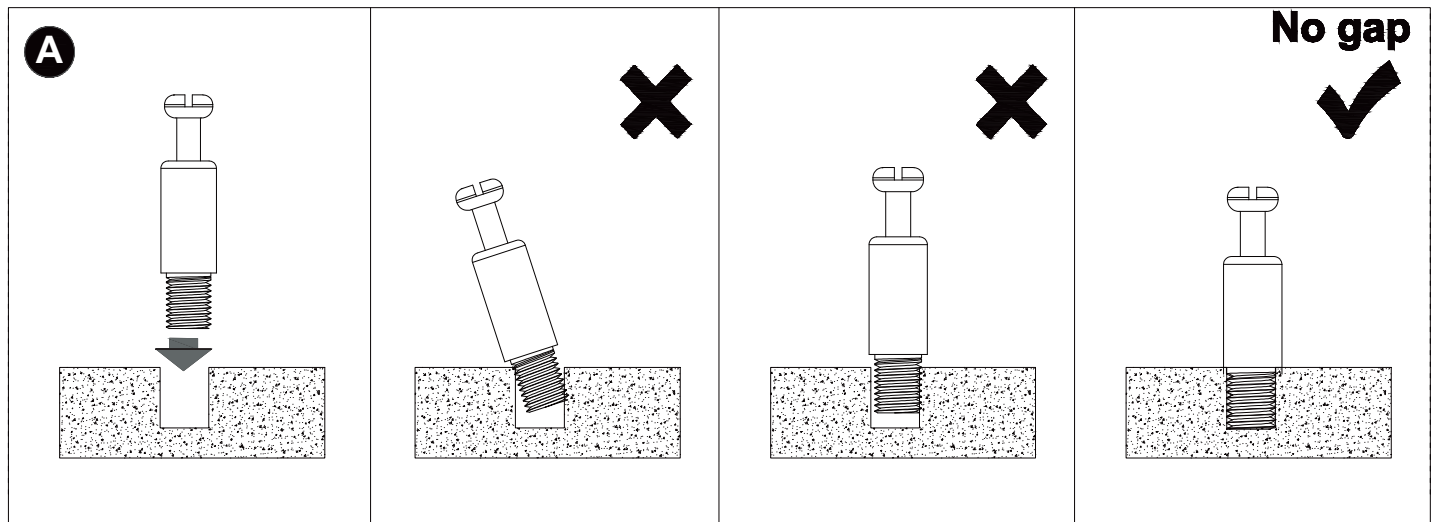
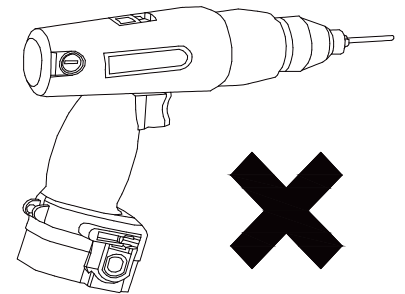

Screw the pin into the hole. Set the cams correctly by aligning the head of the cams with the lock pins. Lock the cam by turning the cam head with a screwdriver until it is tightened. Please do not use an electric screwdriver to assemble the unit.

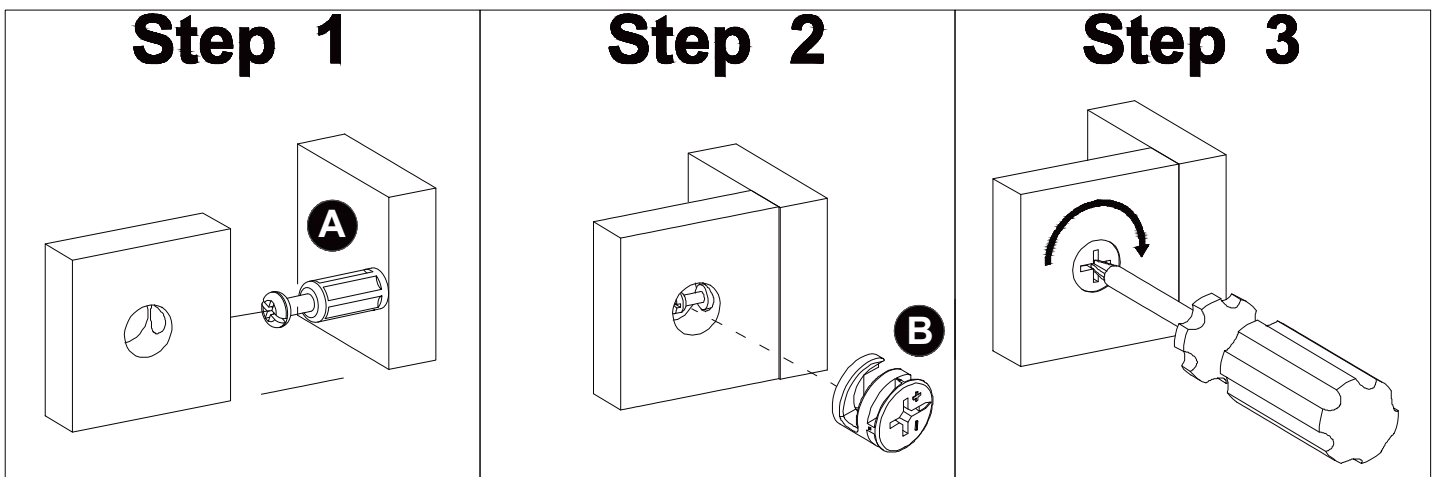

1

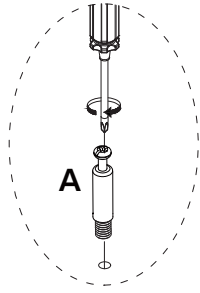

<b>A</b>

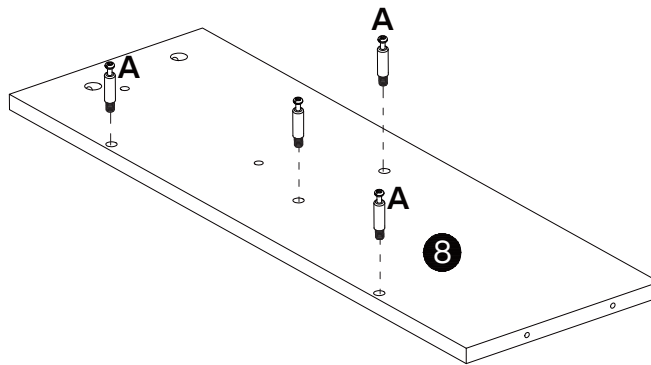
M6x40mm
4 pcs



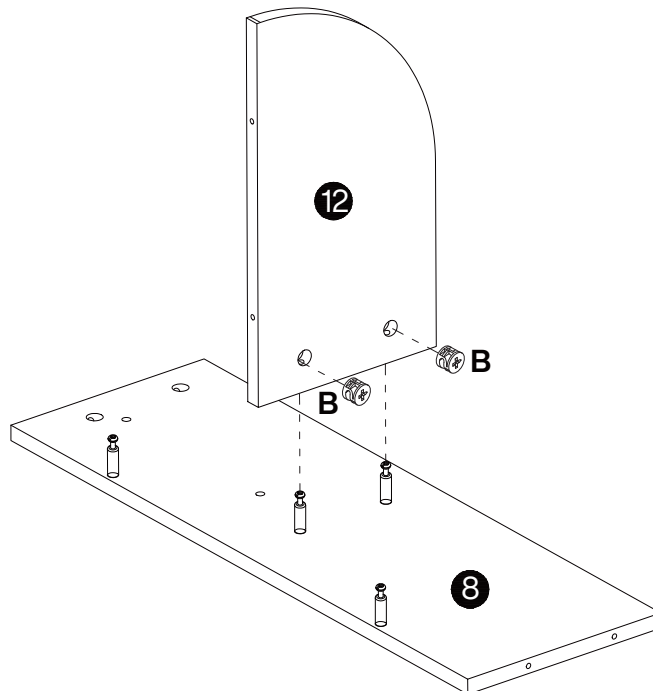
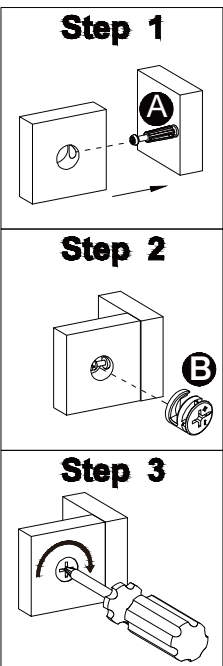

2

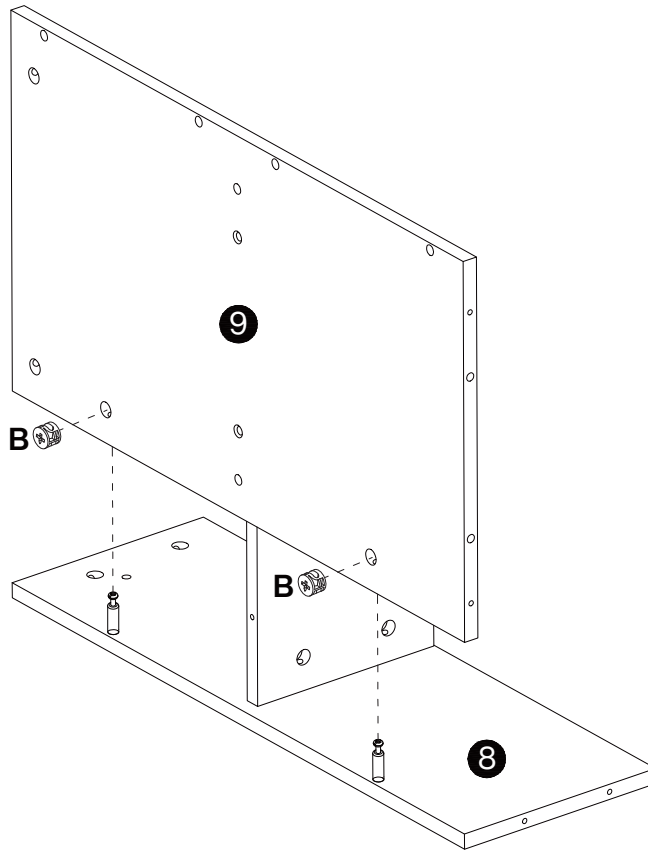
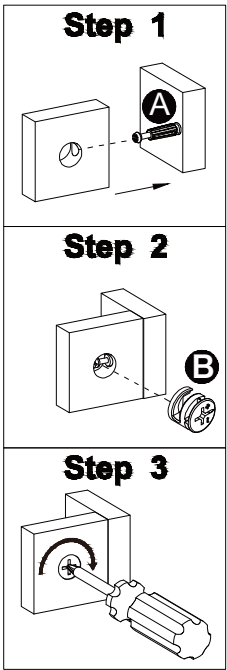

<b>B</b>

Ø15x10mm
2 pcs

# 3

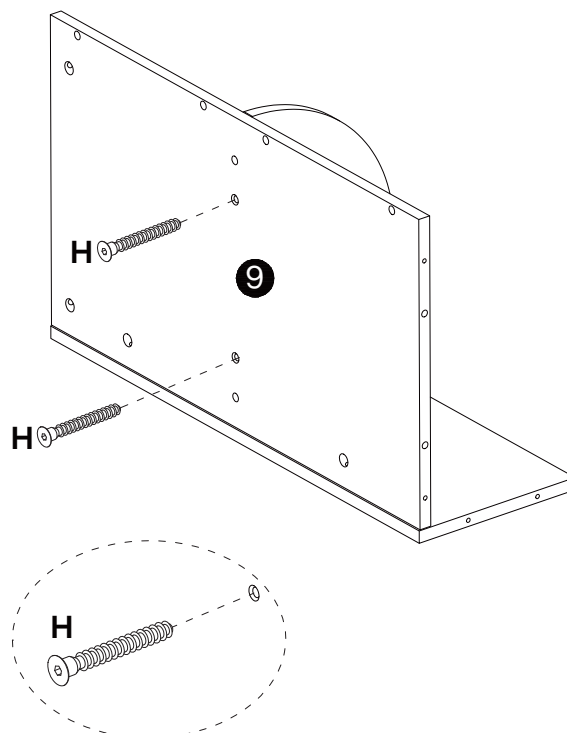

<b>B</b>

Ø15x10mm 2 pcs

# 4

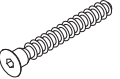

<b>H</b>

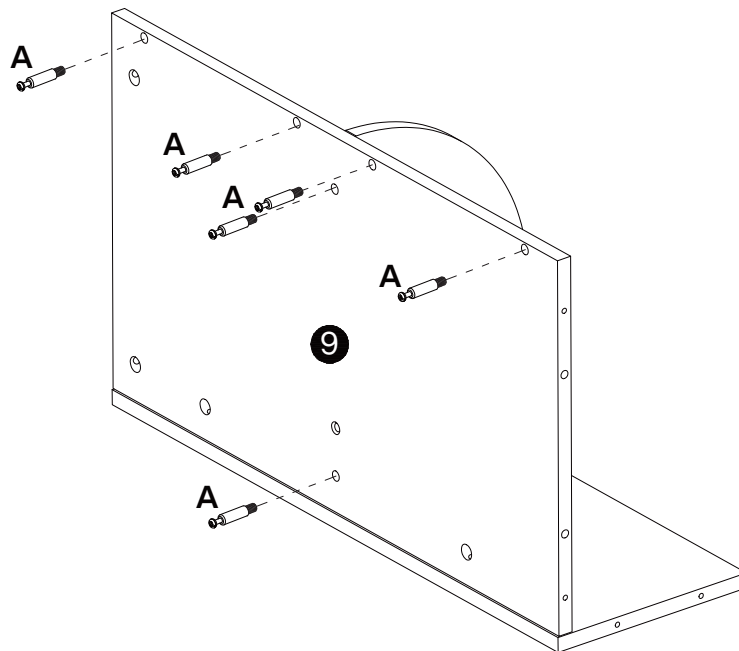
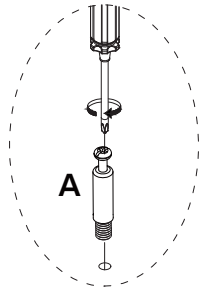
ST6x40mm 2 pcs

5

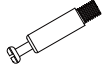

<b>A</b>

M6x40mm
6 pcs

6

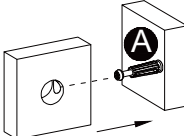
**Step 1**

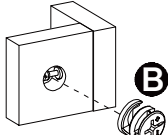

**Step 2**



**Step 3**

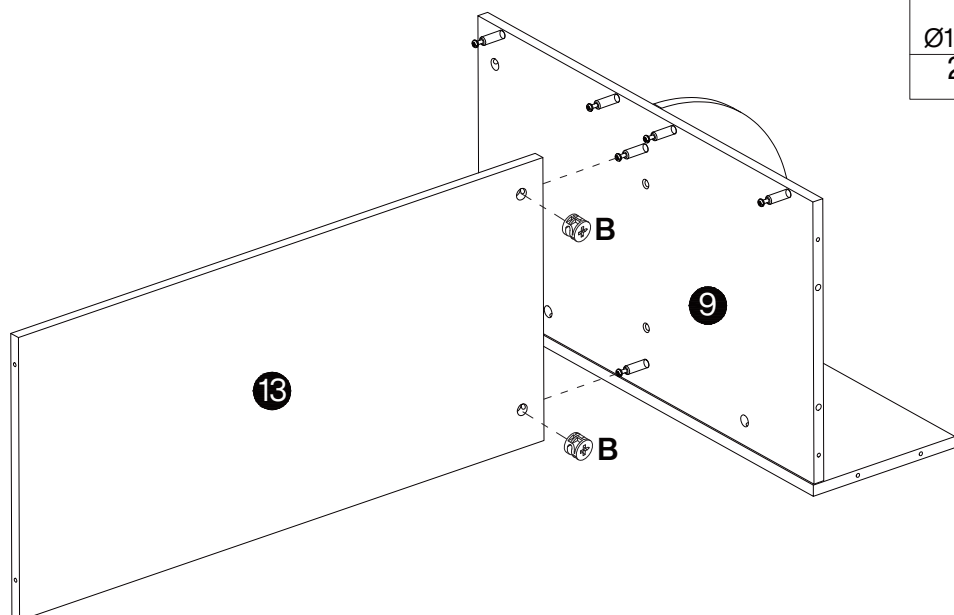
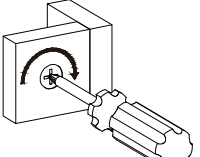

<b>B</b>

Ø15x10mm
2 pcs

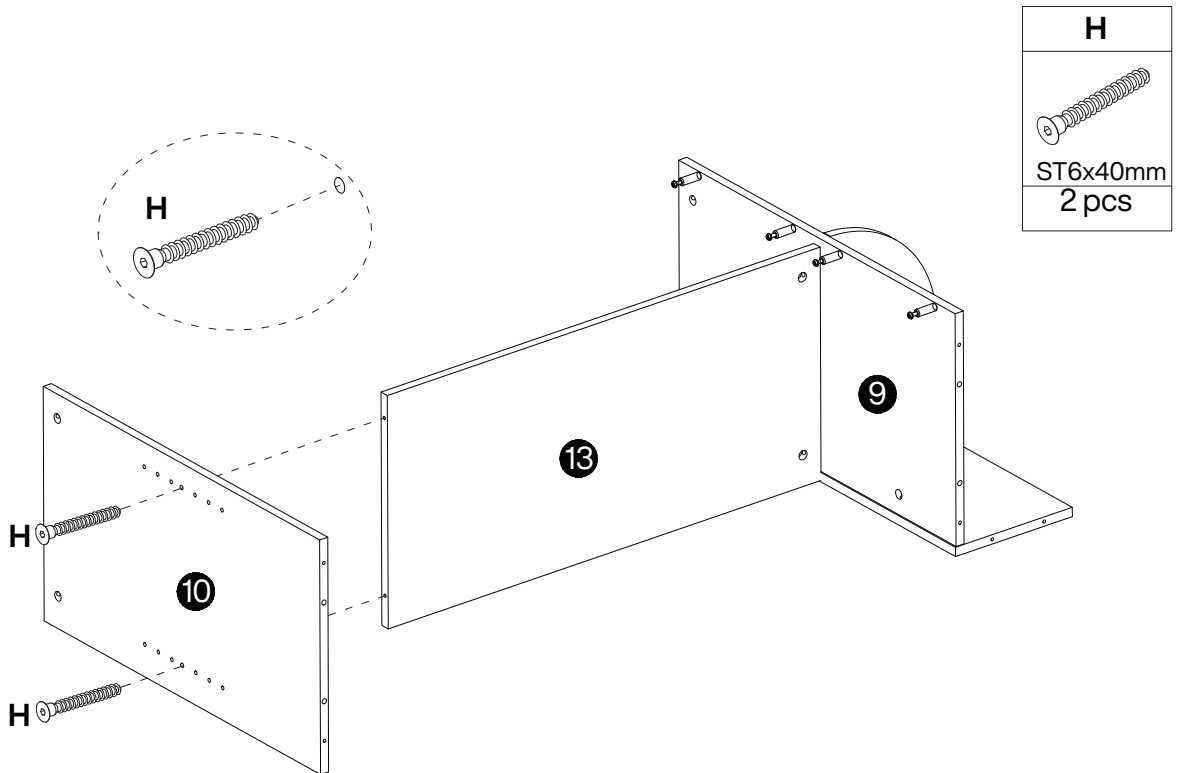
7

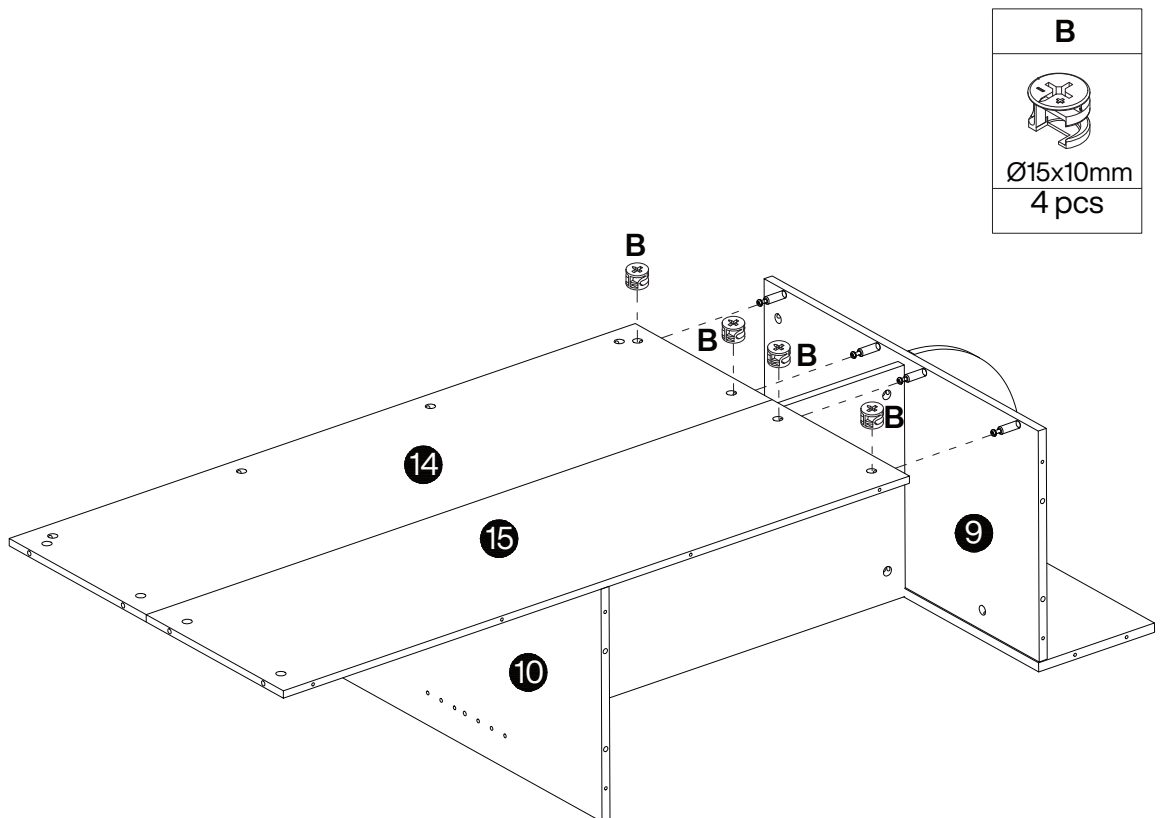
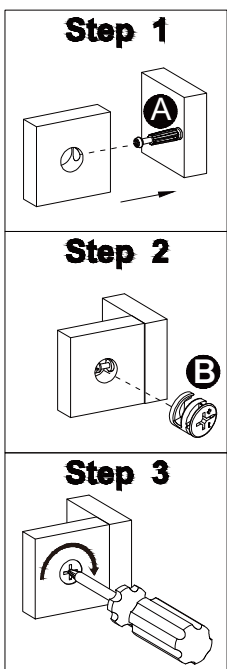

8



9

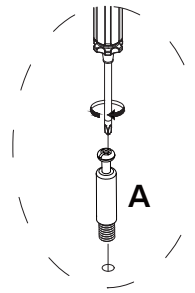

<b>A</b>

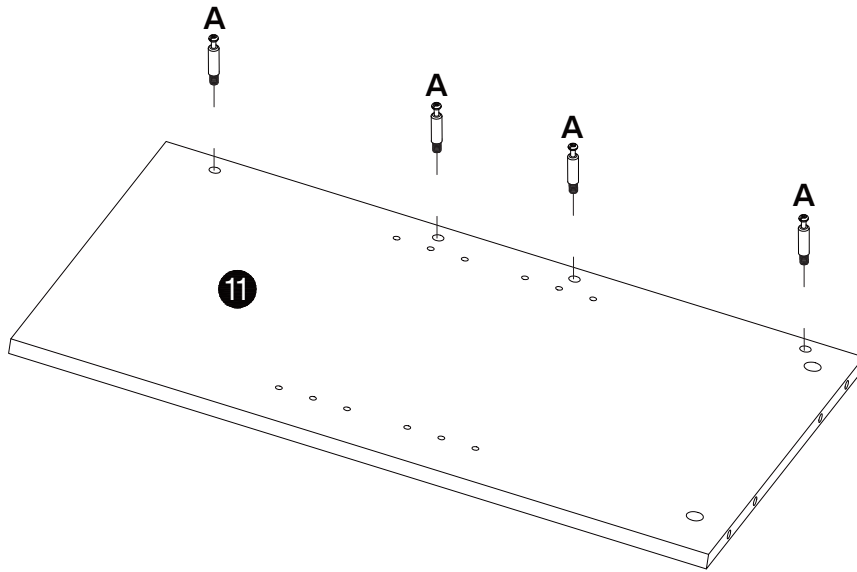
M6x40mm
4 pcs

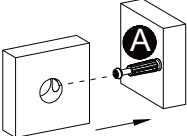

10

**Step 1**



**Step 2**

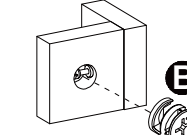

**Step 3**

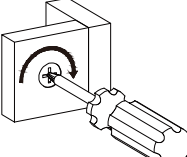

<b>B</b>

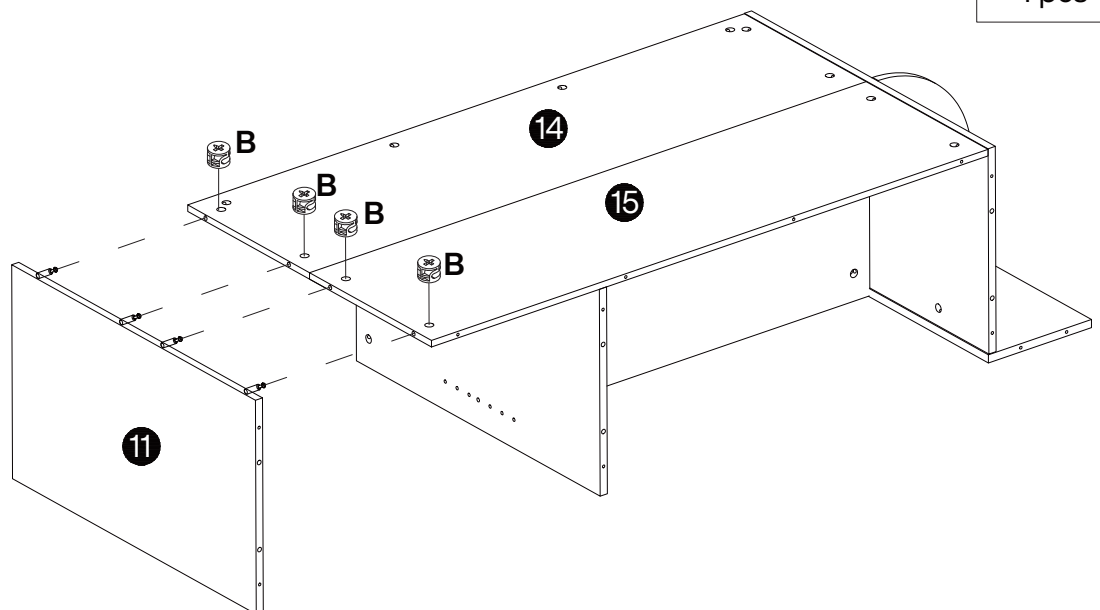
Ø15x10mm
4 pcs

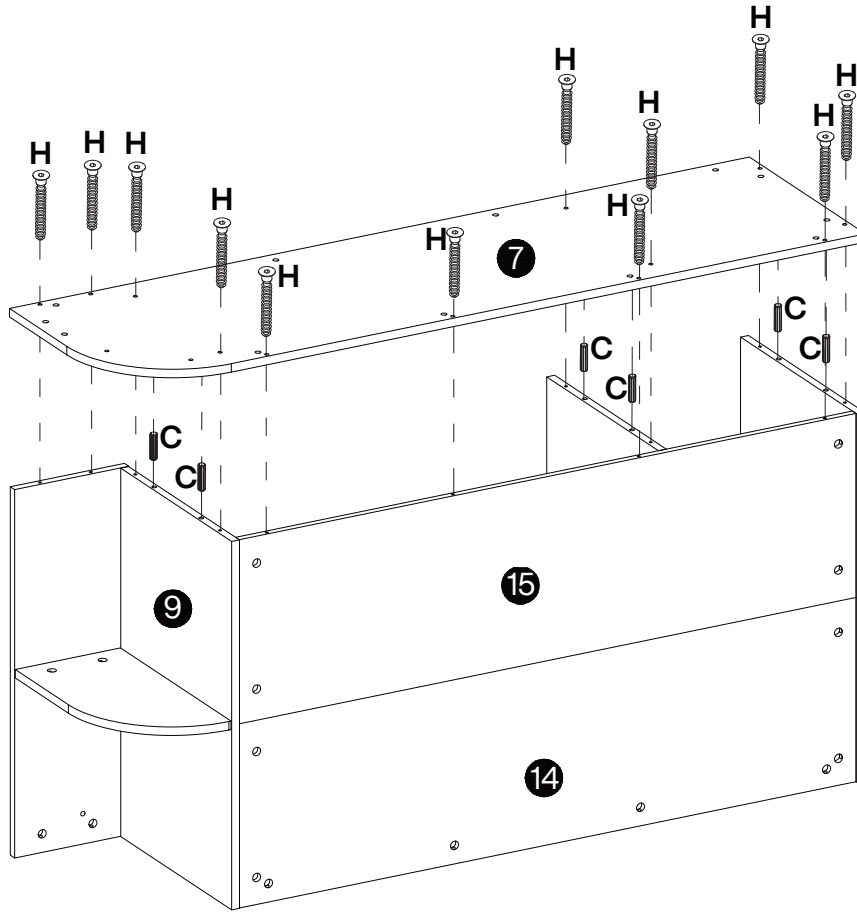
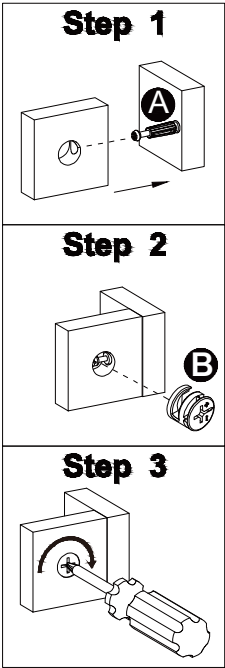

# 11

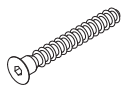
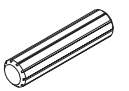

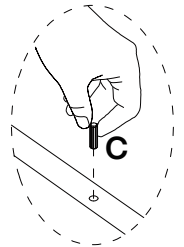
<b>H</b>

ST6x40mm 12 pcs
<b>C</b>

Ø8x35mm 6 pcs

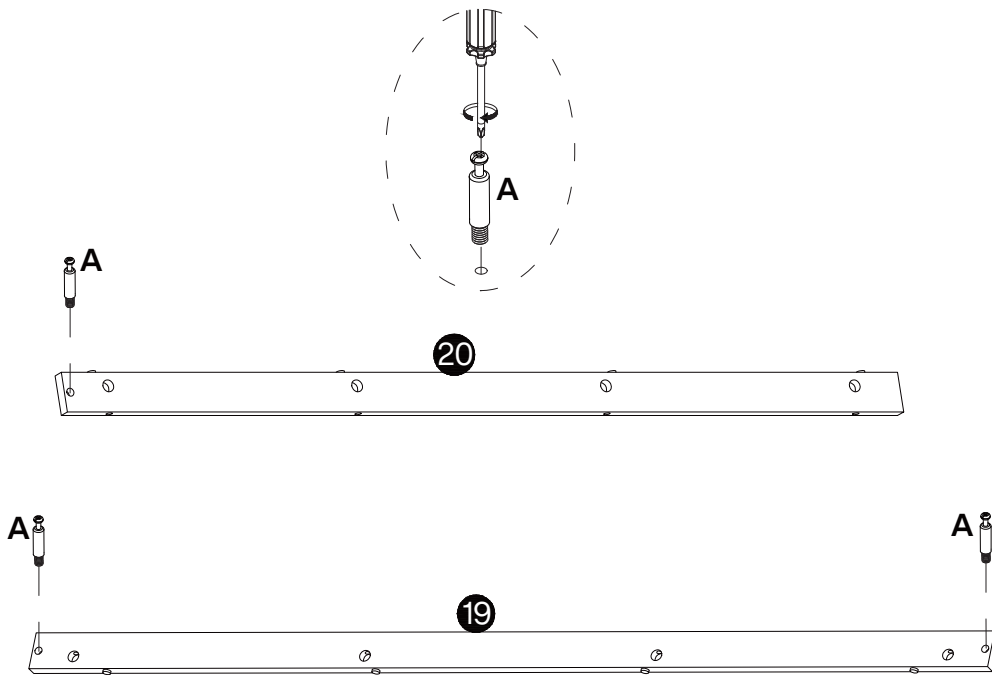



# 12

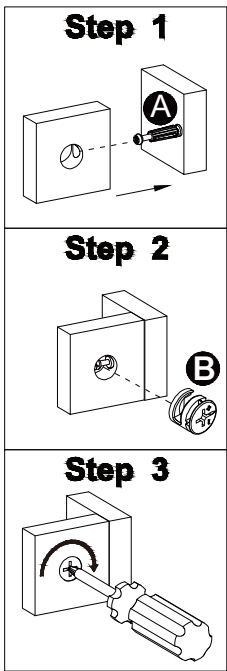

<b>A</b>

M6x40mm 3 pcs

13

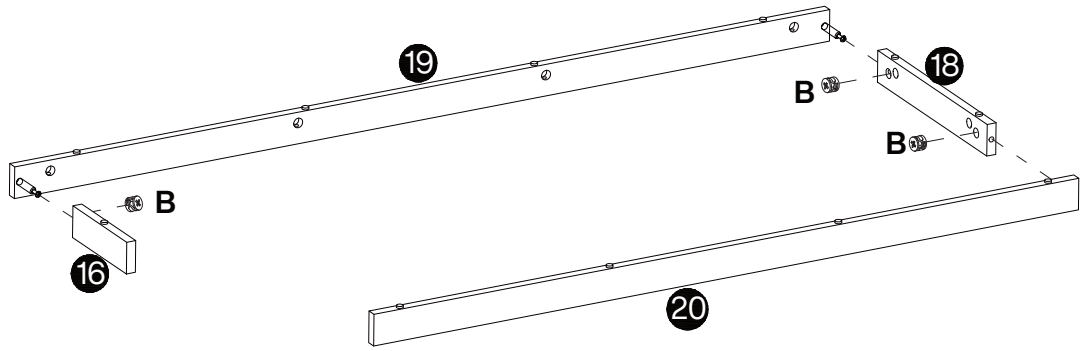

<b>B</b>

Ø15x10mm 3 pcs

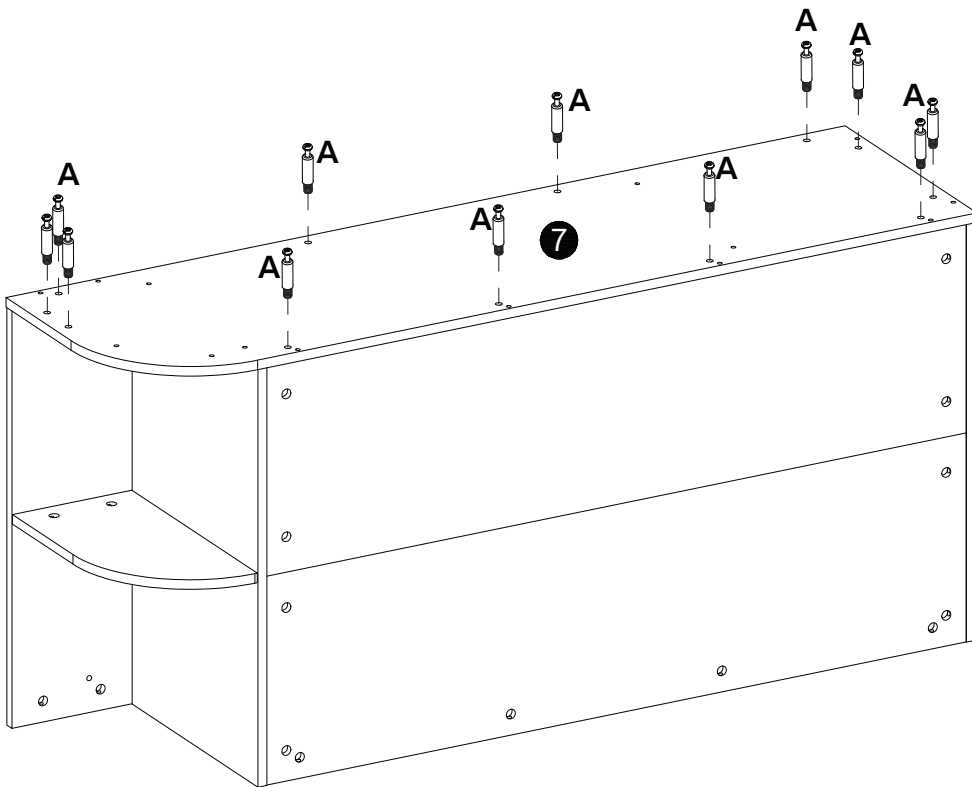

14



<b>A</b>

M6x40mm 12 pcs

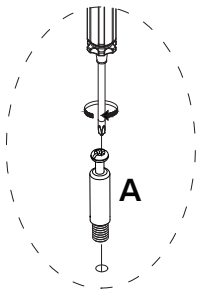

# 15

**Step 1**

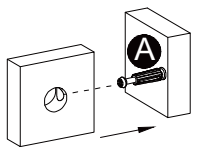

**Step 2**

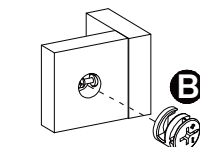

**Step 3**

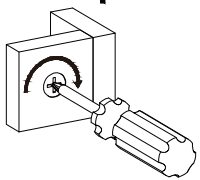
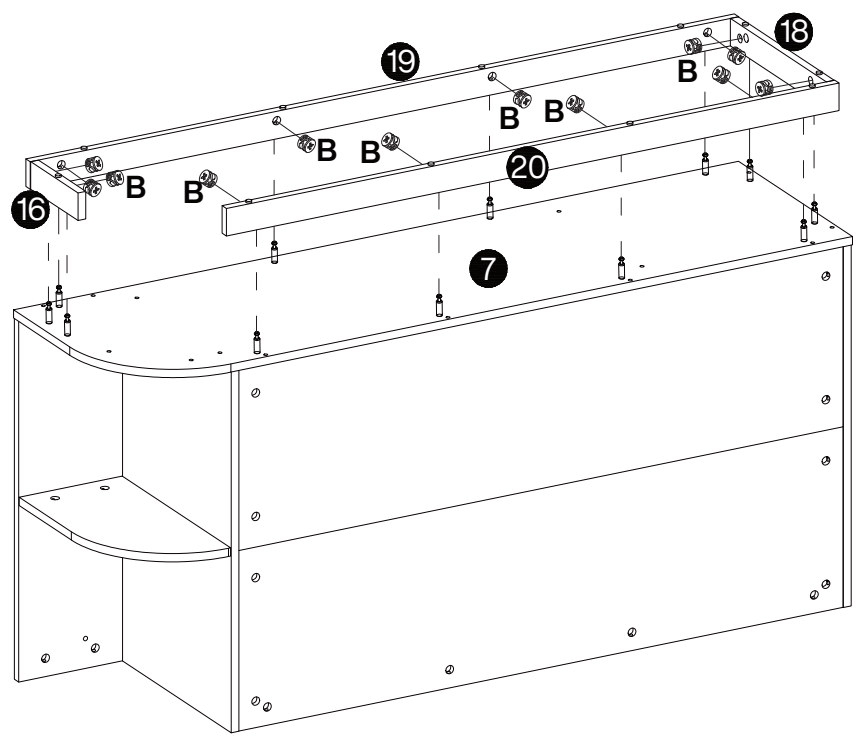
<b>B</b>

Ø15x10mm 12 pcs

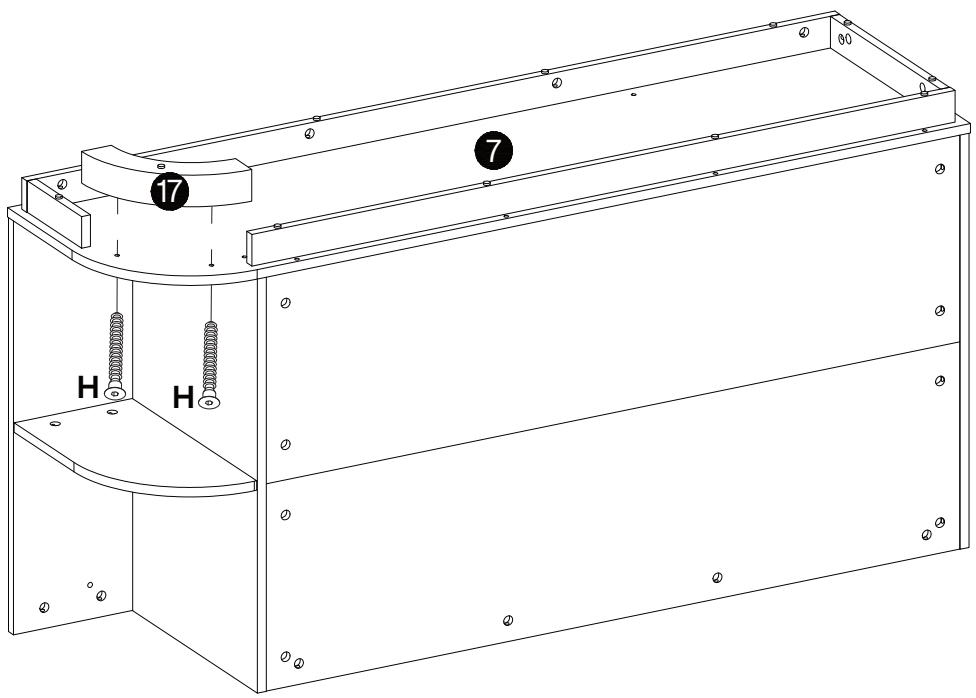

# 16

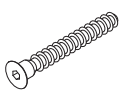

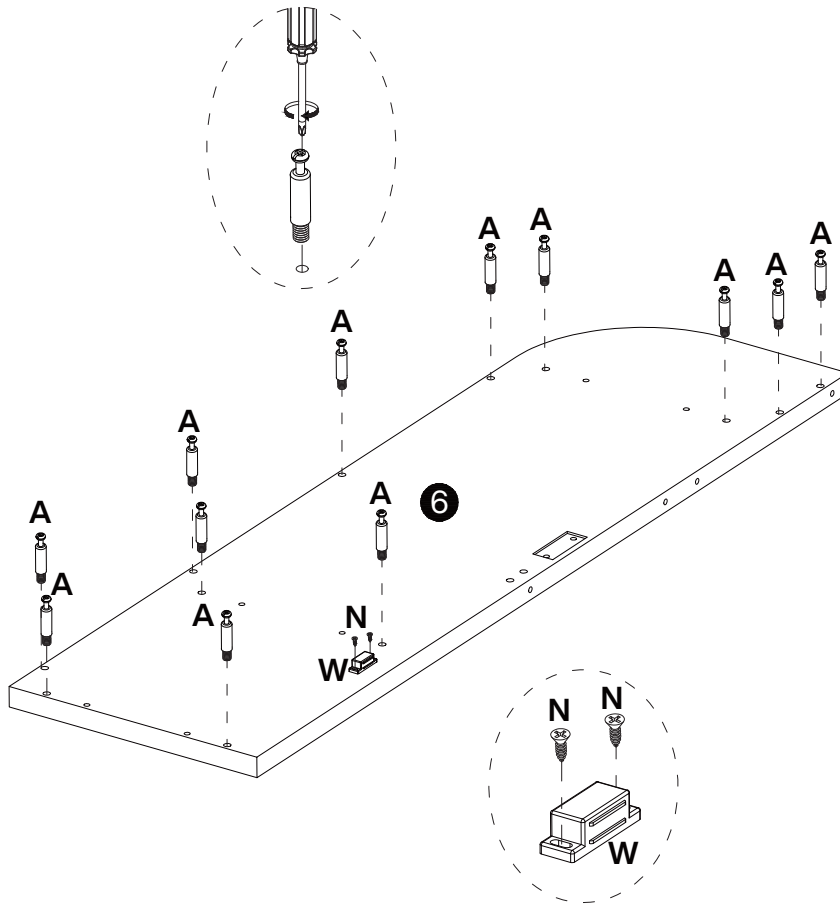
<b>H</b>

ST6x40mm 2 pcs

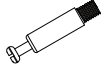
17

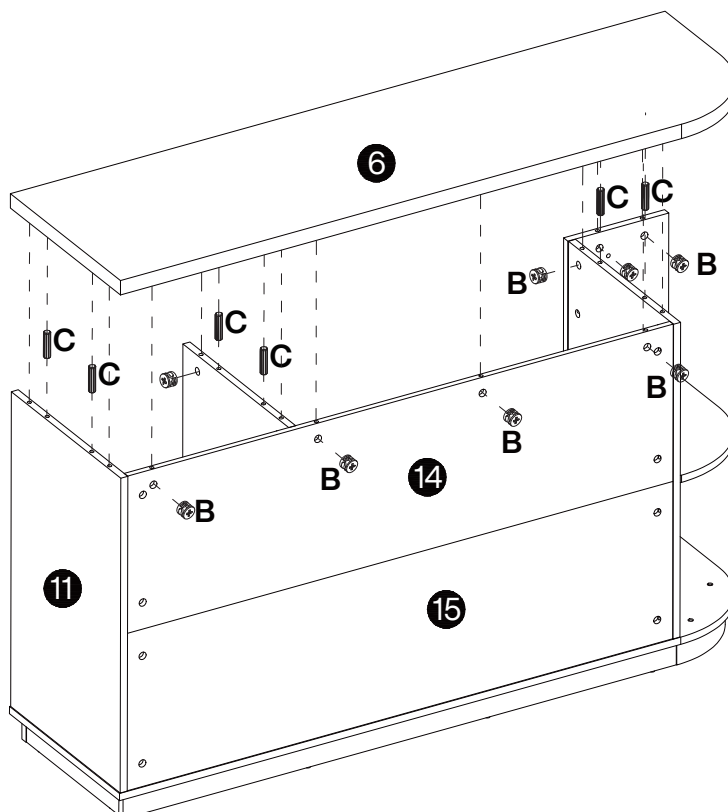
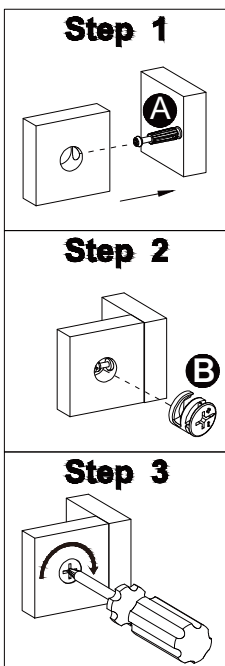

<b>A</b>

M6x40mm 12 pcs
<b>N</b>

ST3.5x14mm 2 pcs
<b>W</b>

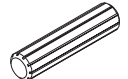
1 pc

18

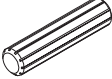

<b>B</b>

Ø15x10mm 12 pcs
<b>C</b>

Ø8x35mm 6 pcs

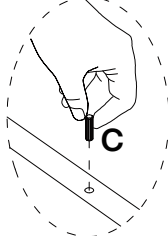
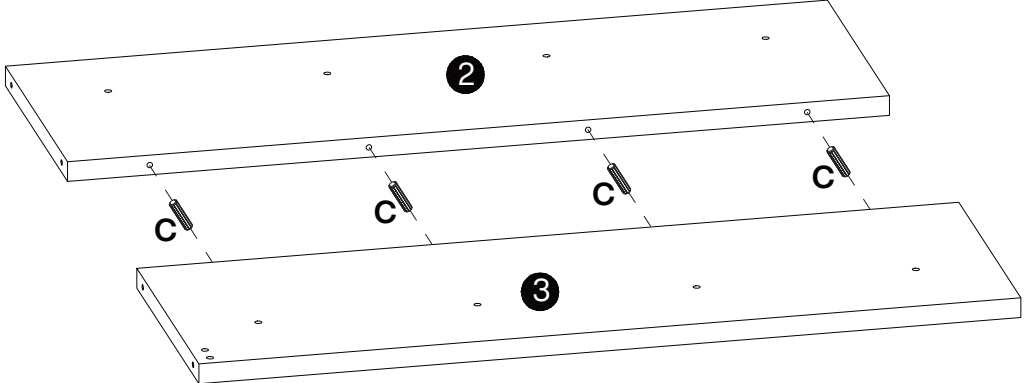
19

<b>C</b>

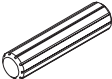
Ø8x35mm
4 pcs



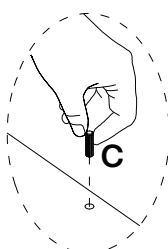
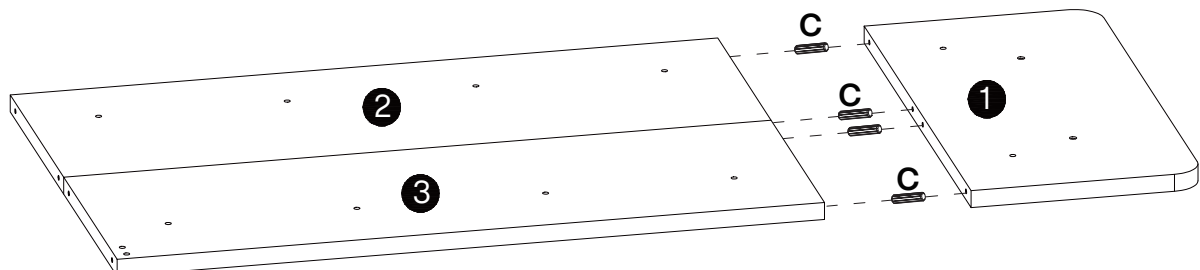

20

<b>C</b>

Ø8x35mm
4 pcs

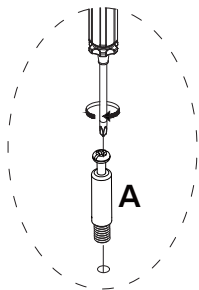

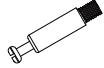
21

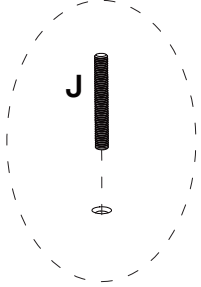
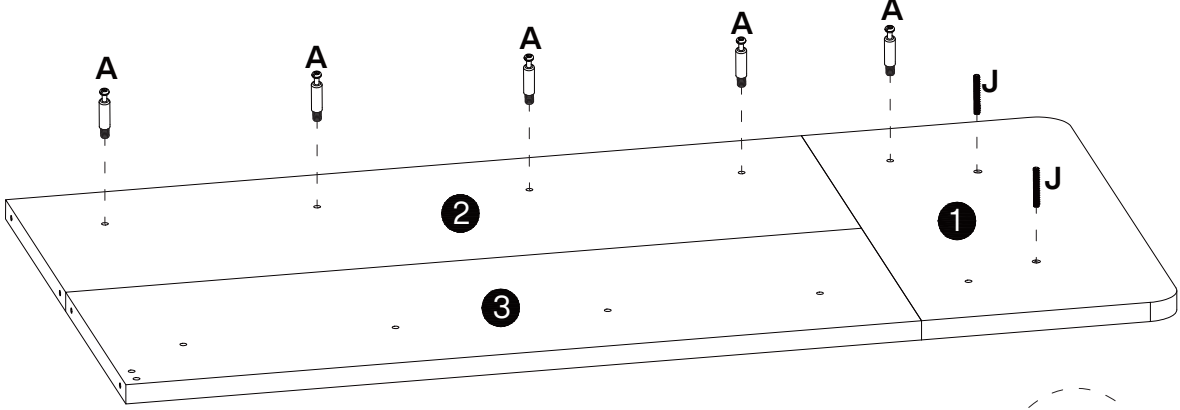

A	J
	
M6x40mm 5 pcs	M8x70mm 2 pcs



22

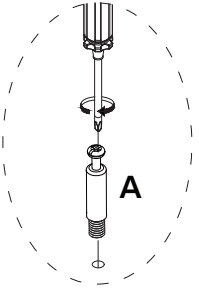

A

M6x40mm 2 pcs

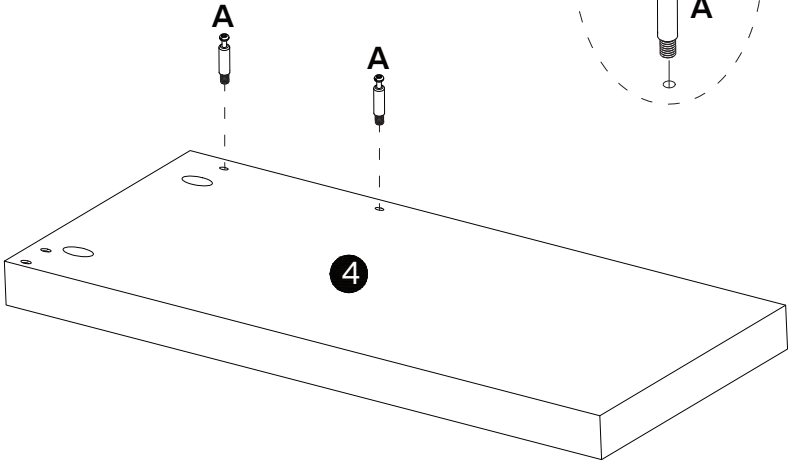

23

<b>B</b>

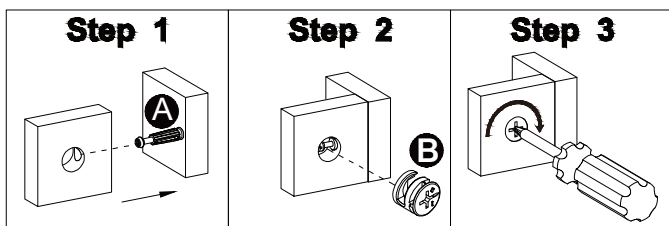
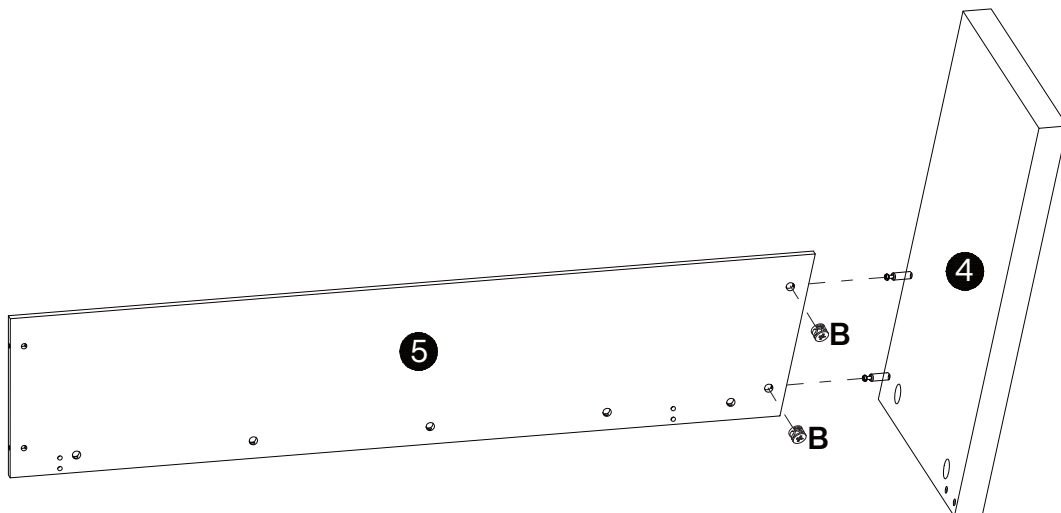
Ø15x10mm
2 pcs





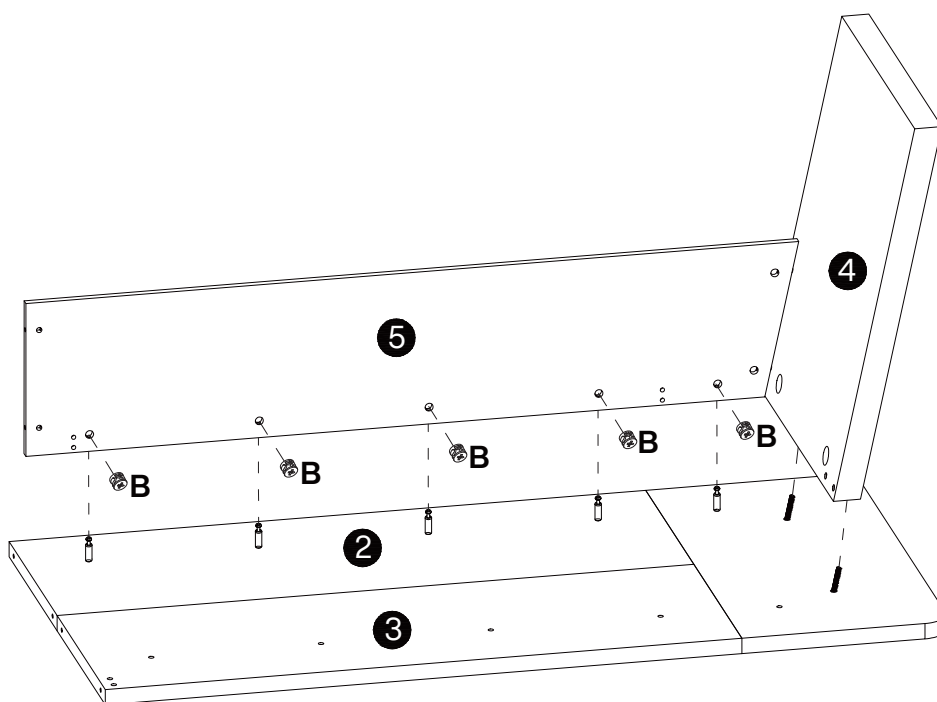
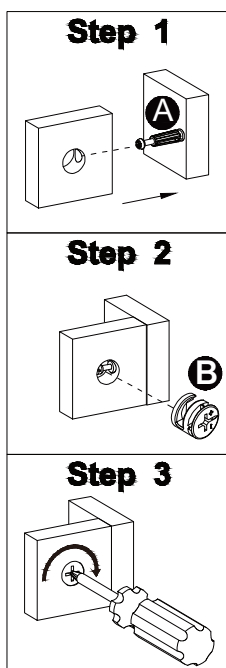

24

<b>B</b>

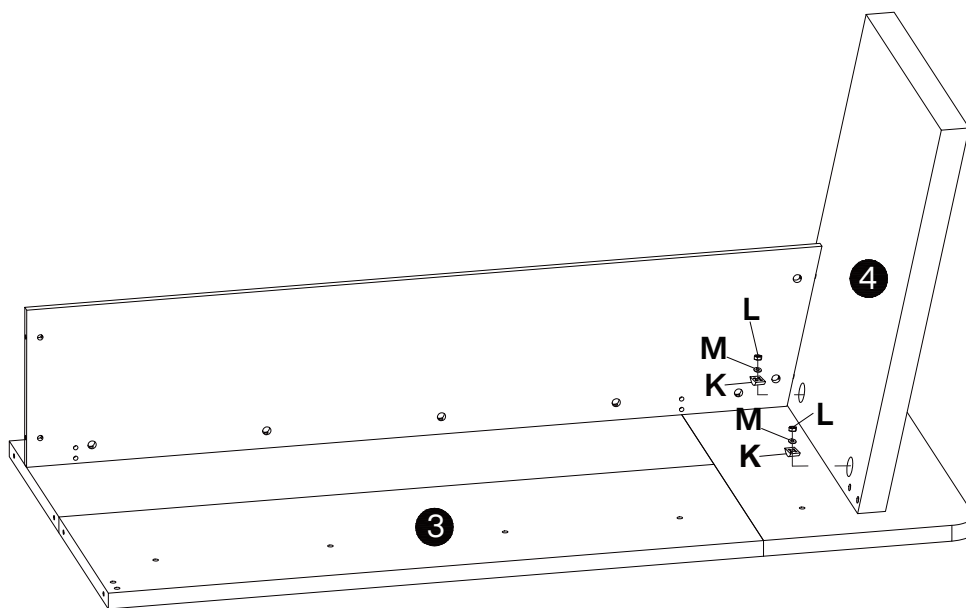
Ø15x10mm
5 pcs



25

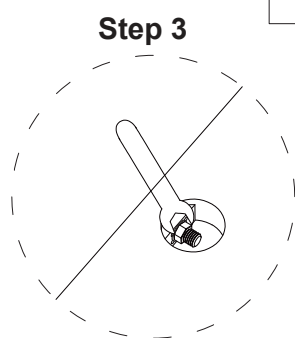
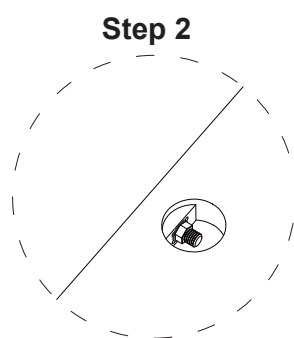
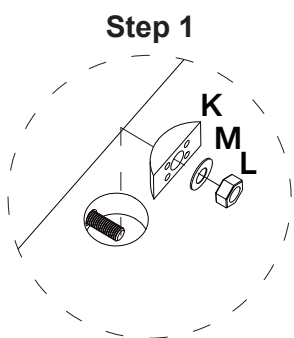

<b>K</b>

M8 2 pcs
<b>L</b>

M8 2 pcs
<b>M</b>

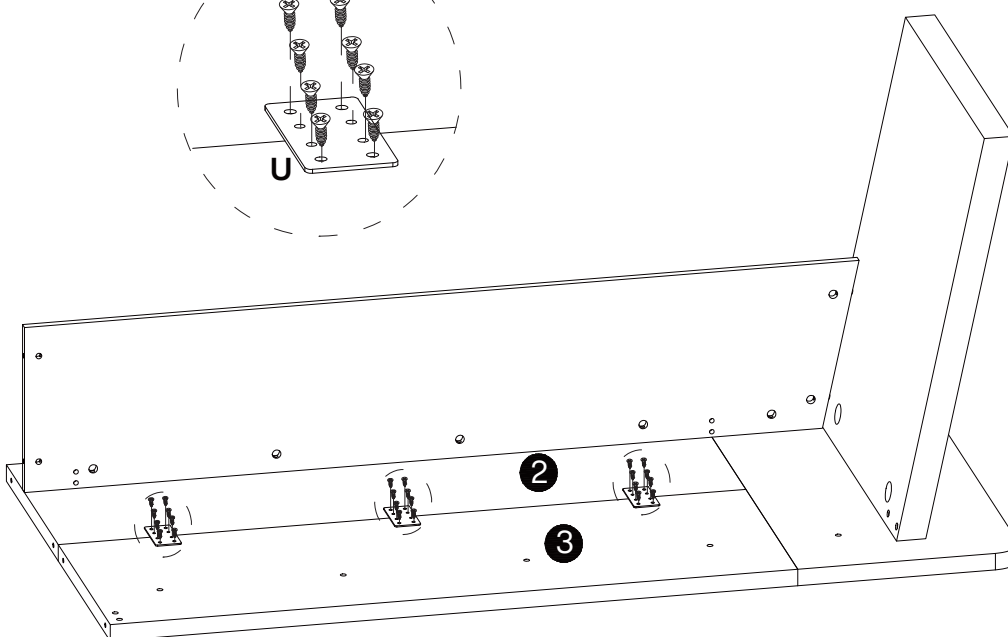
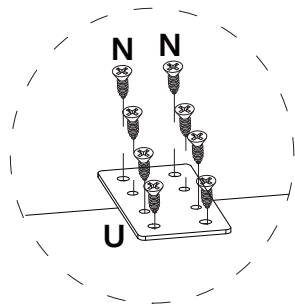
2 pcs

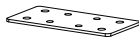



26

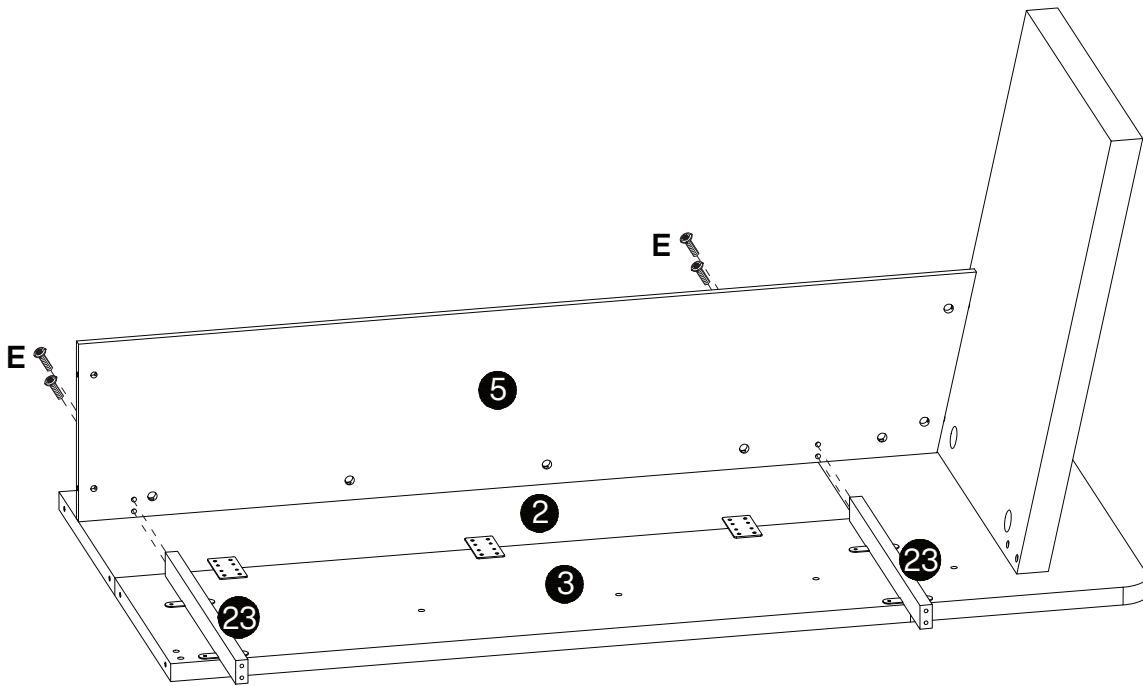

<b>N</b>

ST3.5x14mm 24 pcs
<b>U</b>

3 pcs

27

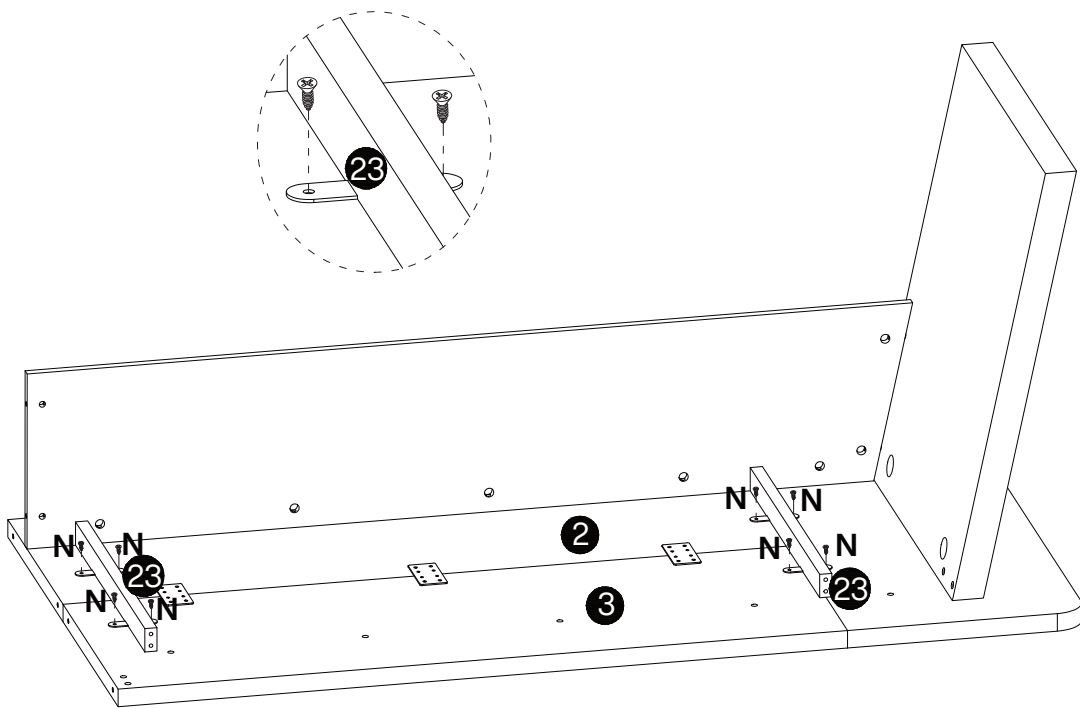

<b>E</b>

M6x40mm 4 pcs

28

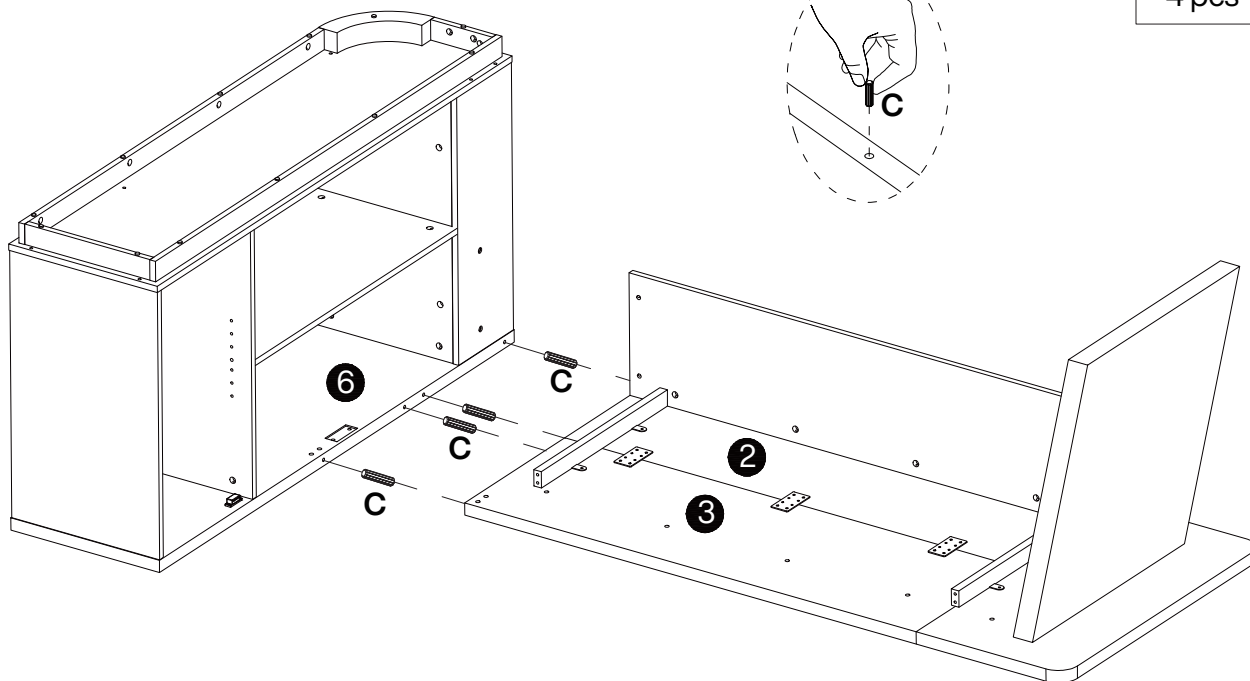

<b>N</b>

ST3.5x14mm 8 pcs

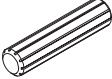

29

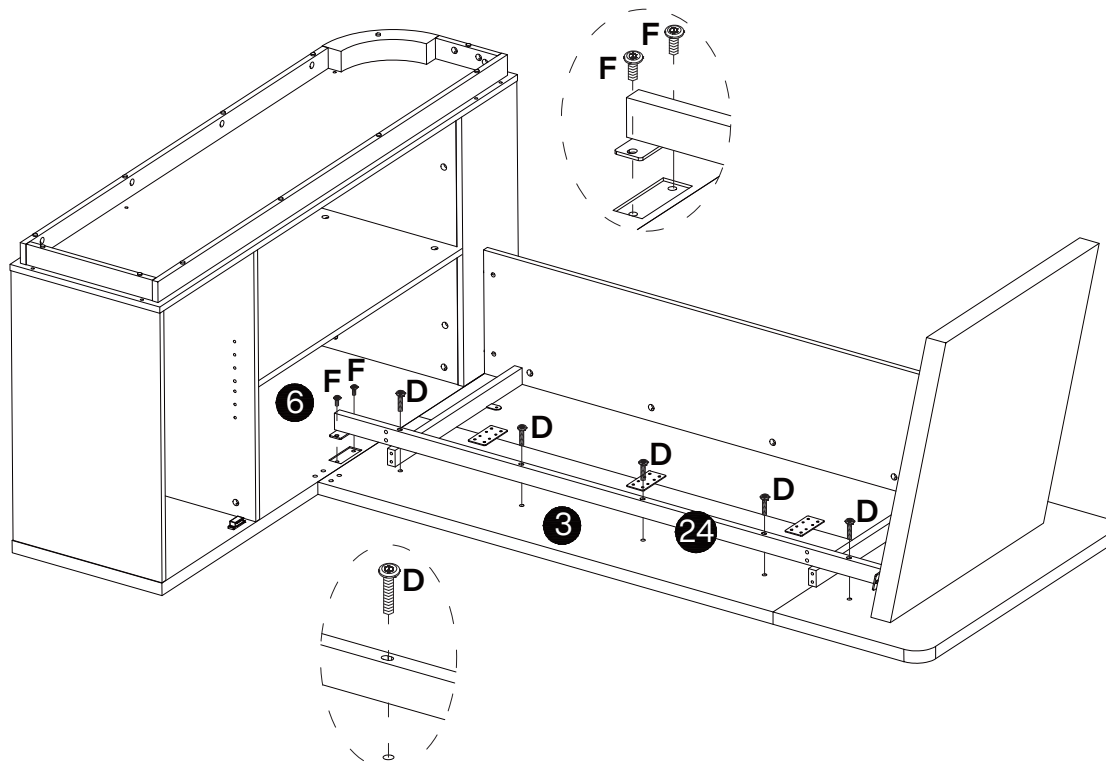

<b>C</b>

Ø8x35mm
4 pcs

30

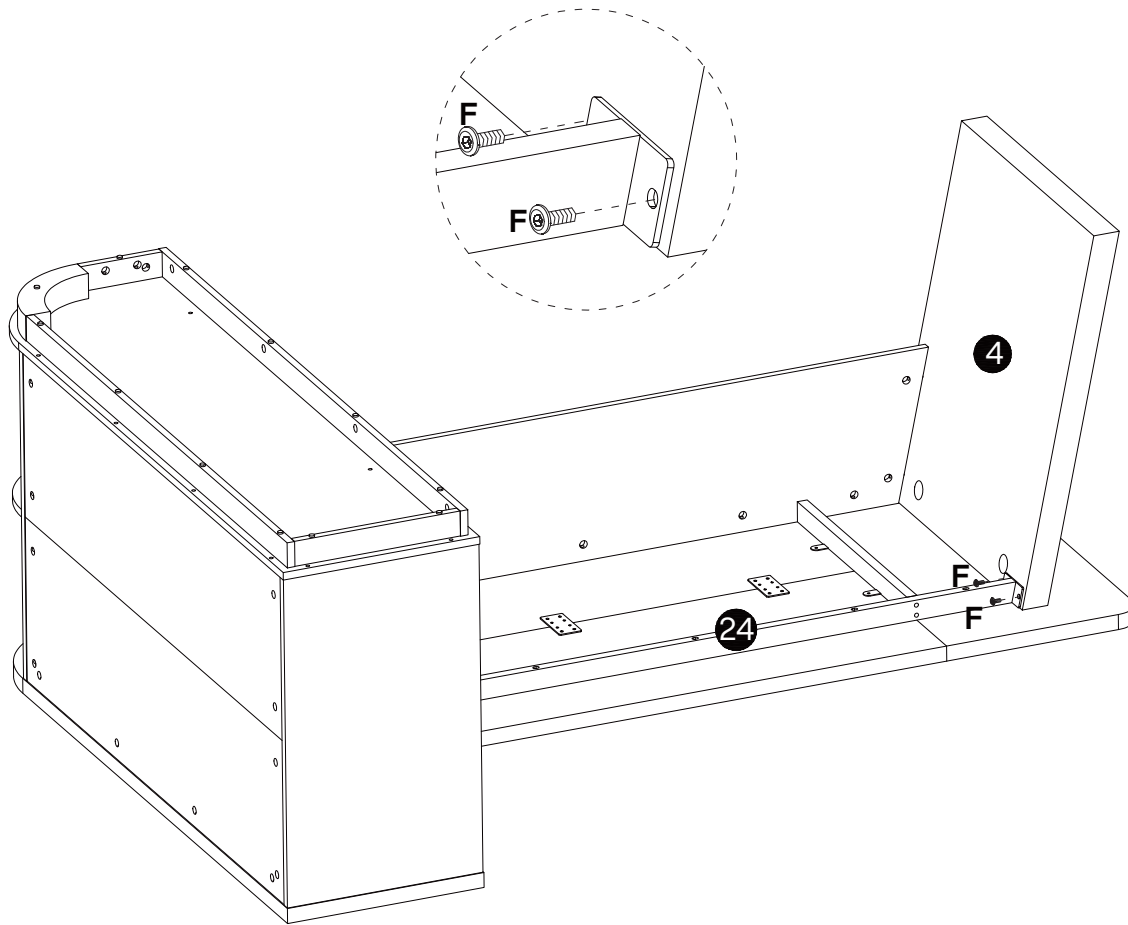

<b>D</b>

M6x55mm
5 pcs
<b>F</b>

M6x20mm
2 pcs

31



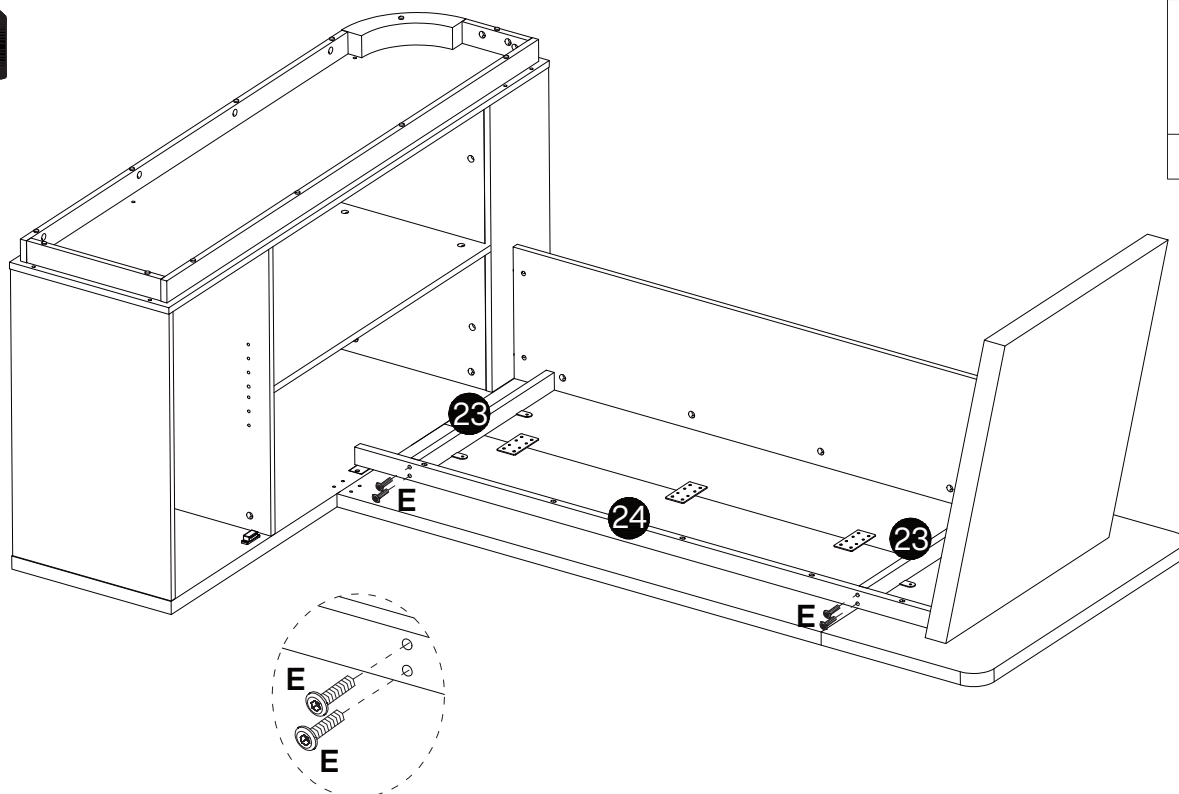

<b>F</b>

M6x20mm
2 pcs

32





<b>E</b>

M6x40mm
4 pcs

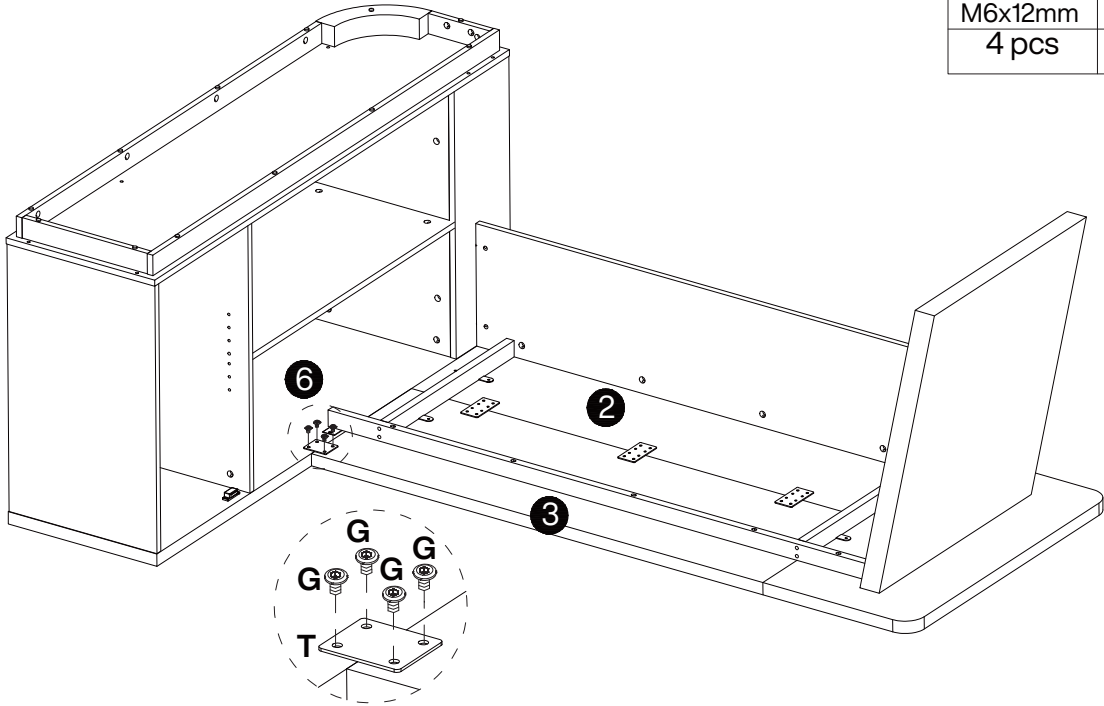
33

G	T
	
M6x12mm 4 pcs	1 pc



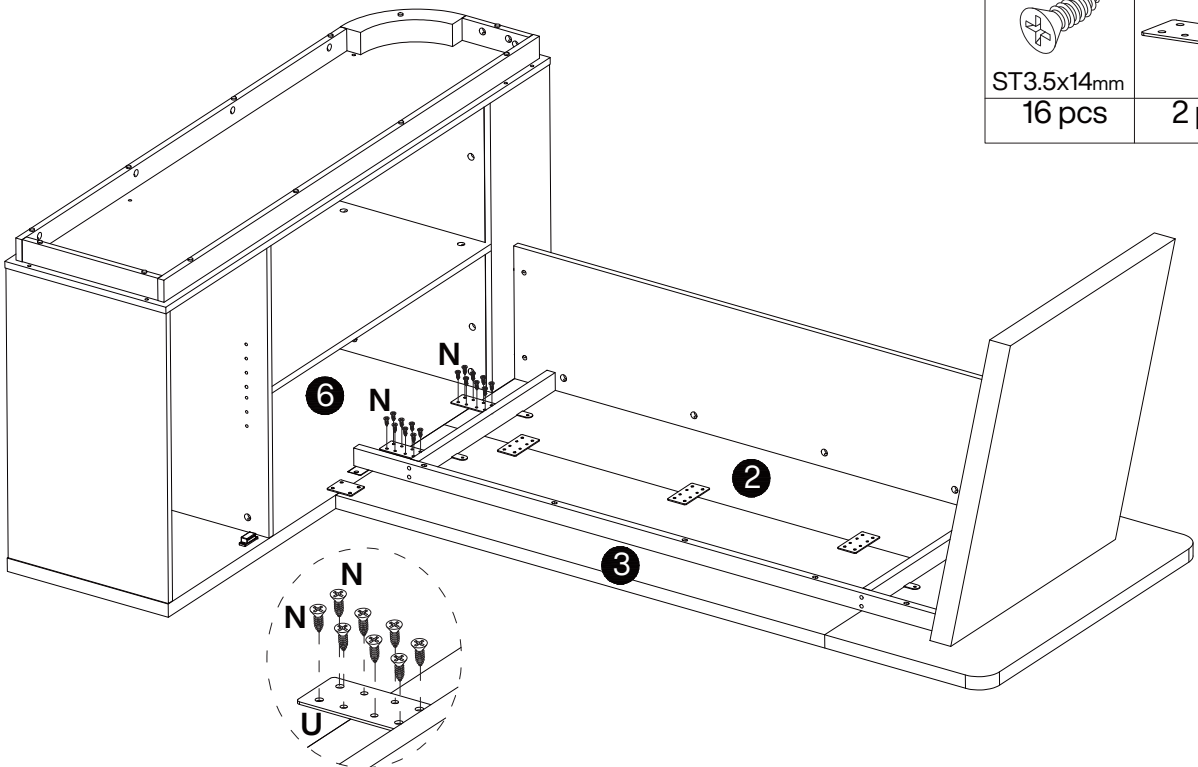

34

N	U
	
ST3.5x14mm 16 pcs	2 pcs

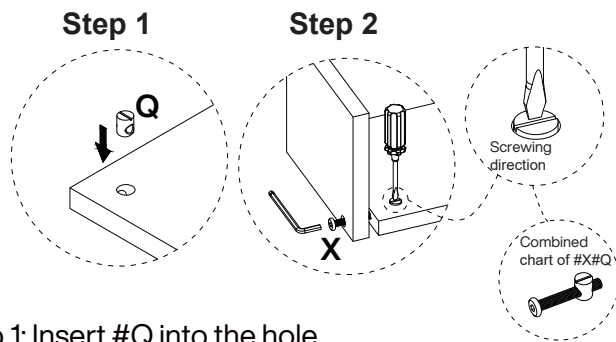

35



X	Q
	
M6x50mm 2 pcs	M6 2 pcs

Step 1: Insert #Q into the hole.  
 Step 2: Using a screwdriver, rotate #Q until its groove aligns with #X. Lock in place by turning #X clockwise.

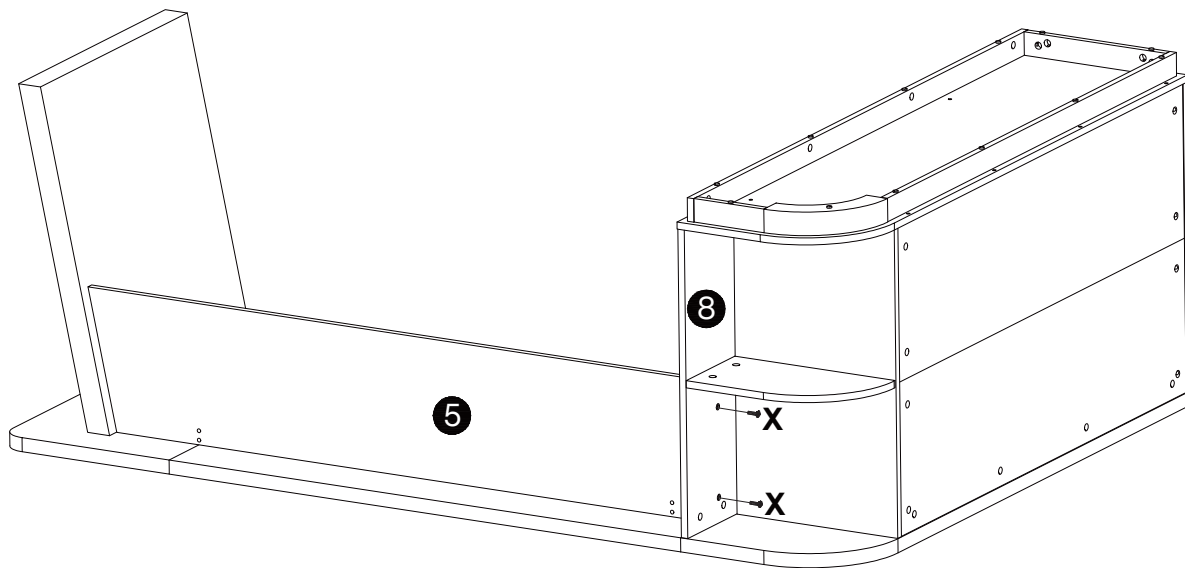





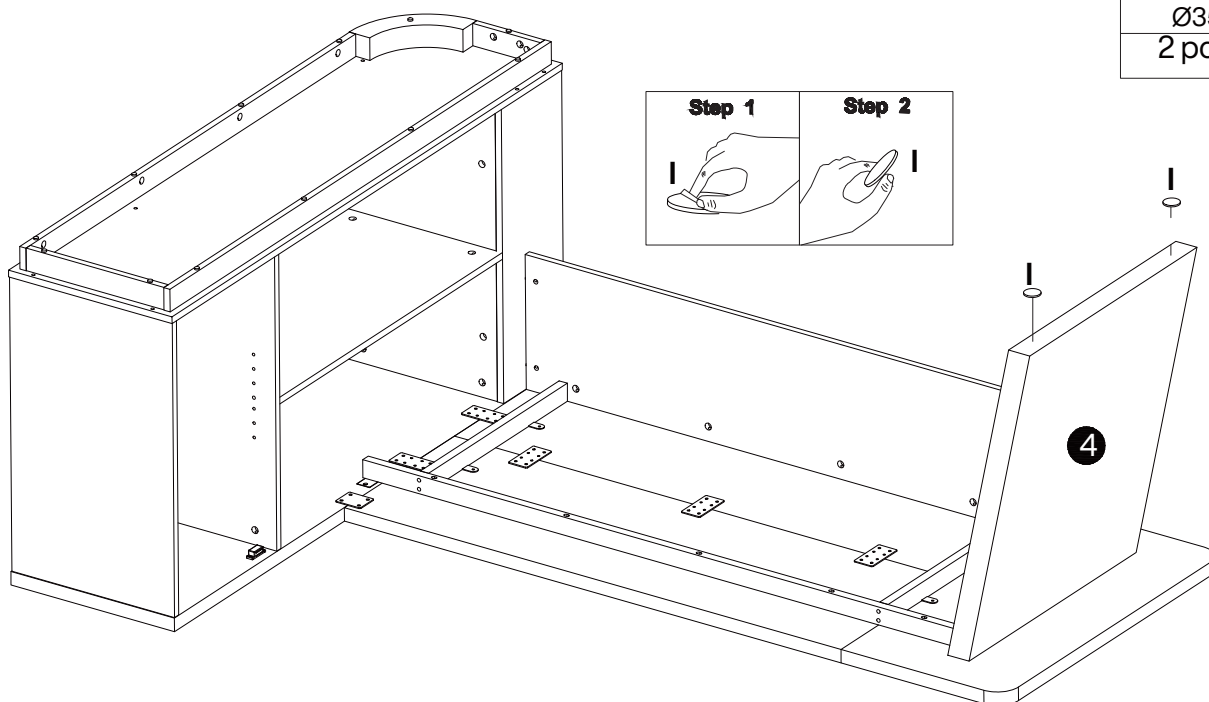
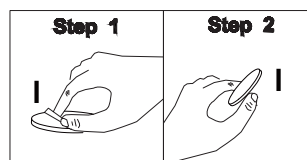

36

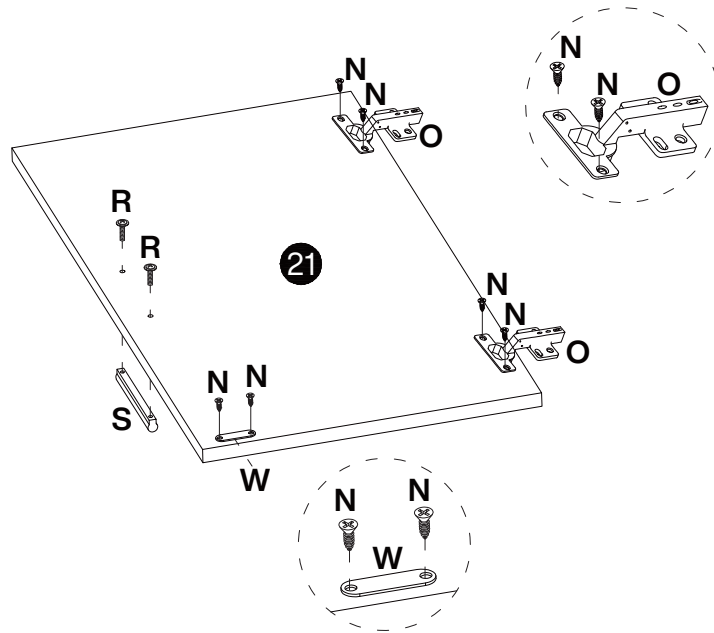
I

Ø35 2 pcs

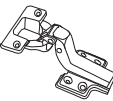



37

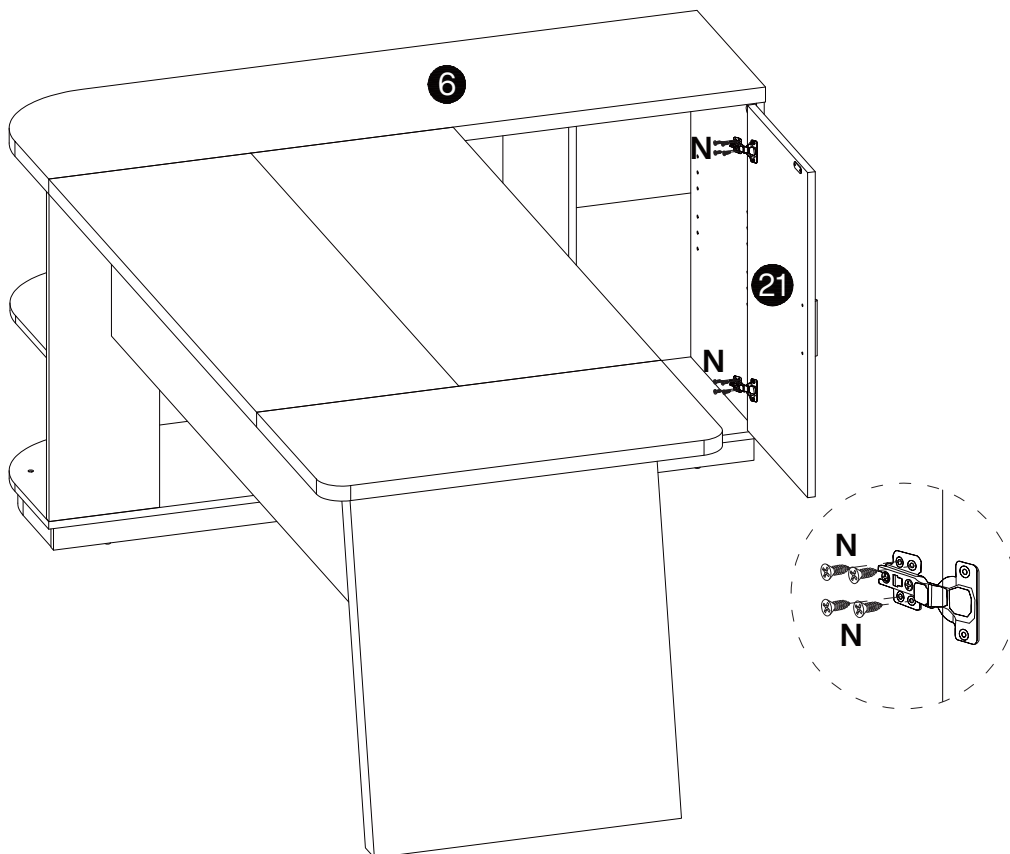

<b>N</b>	<b>O</b>
	
ST3.5x14mm 6 pcs	2 pcs
<b>R</b>	<b>S</b>
	
M4x18mm 2 pcs	1 pc
	<b>W</b>
	
	1 pc

38



<b>N</b>

ST3.5x14mm 8 pcs

## Step 1

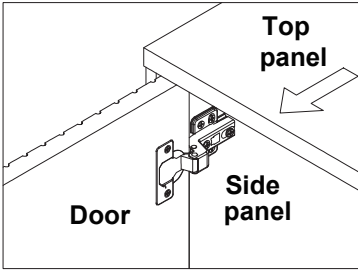
Open the door.



# ADJUST YOUR DOORS TO MAKE THE GAPS MORE EVEN (OPTIONAL).

## Step 2

Adjust the door panel to be flush with side panel and top panel edge.

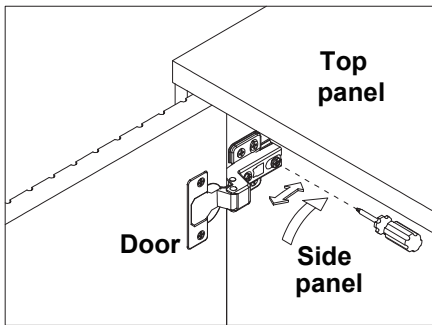

Loosen the screw indicated a little, adjust the hinge to the right position (see step 2a & 2b), then tighten the screw.

### Step 2a MOVE DOOR OUT

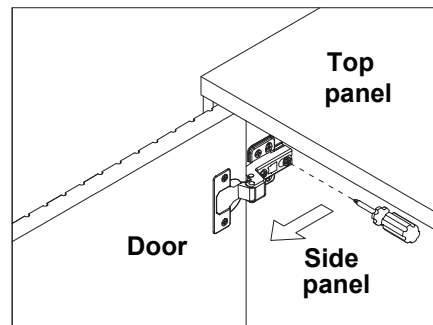
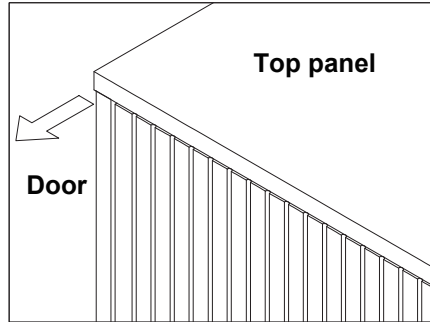

Pull the hinge forward a little.

### Step 2b MOVE DOOR IN

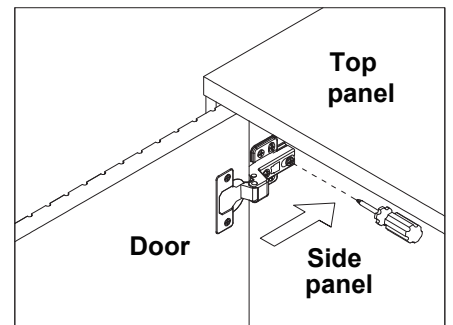
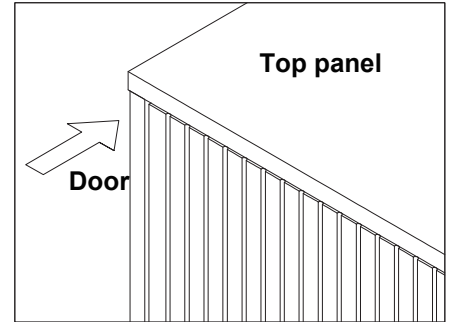

Push the hinge back a little.

## Step 3

Adjust the gap between the door panel and the side panel.

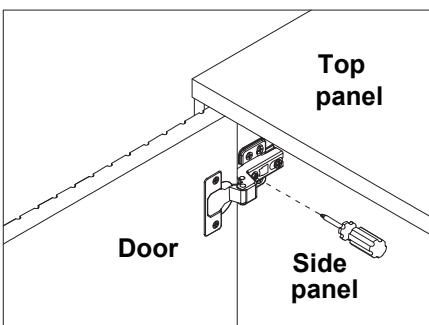

Loosen or tighten the screw indicated a little to adjust the gap between the door panels, adjust the hinge to the right position (see step 3a & 3b).

### Step 3a MOVE DOOR LEFT

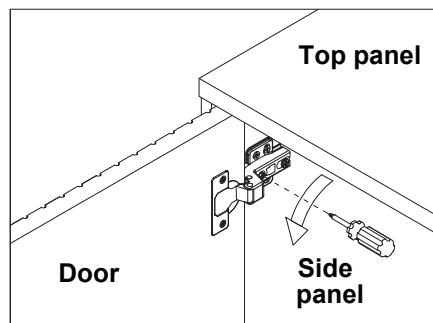
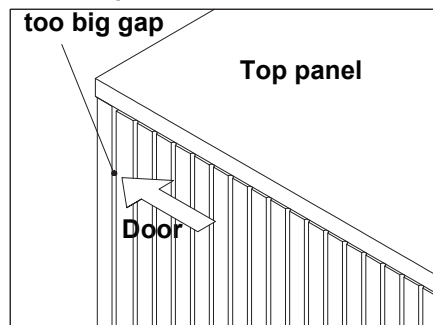

Turn the screw clockwise a little as shown to make the gap smaller

### Step 3b MOVE DOOR RIGHT

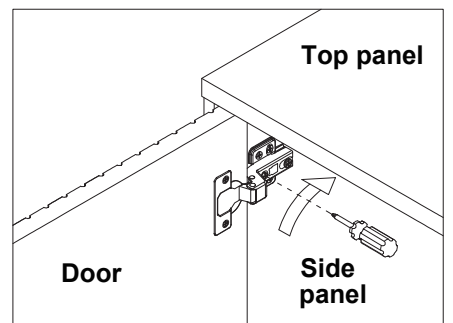
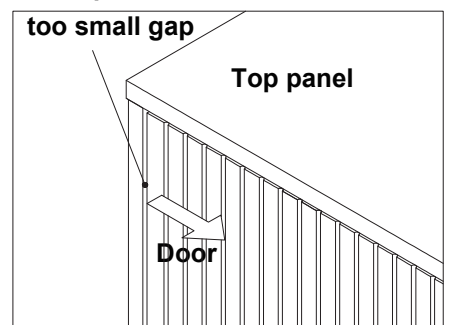

Turn the screw counterclockwise a little as shown to make the gap bigger

39

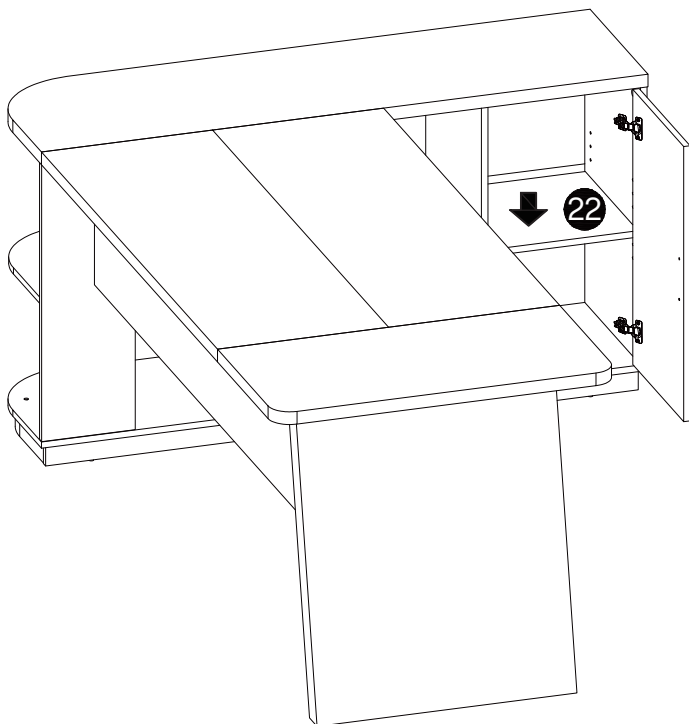

<b>P</b>

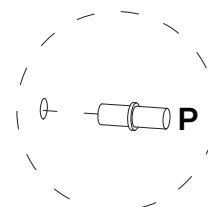
4 pcs

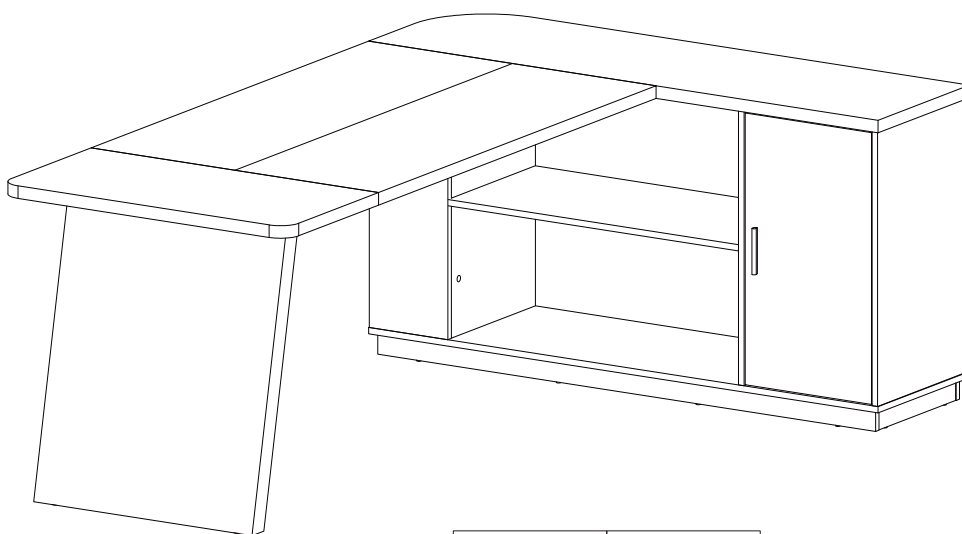

40

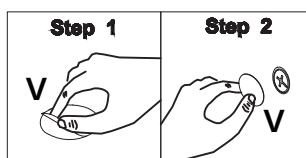

<b>V</b>

Ø20
24 pcs



**Thank you for your support!**

