

# Mechanical Arm Dual Ultrawide Monitor Desk Mount

SKU: STAND-V200D/W  
Instruction Manual

Assembly Video & Product Info  
[www.vivo-us.com/products/stand-v200d](http://www.vivo-us.com/products/stand-v200d)



[ THIS PAGE HAS BEEN INTENTIONALLY LEFT BLANK ]

# ⚠ CAUTION! ⚠

If you do not understand these directions, or if you have any doubts about the safety of the installation, please contact our product support team at 309-278-5303 or [help@vivo-us.com](mailto:help@vivo-us.com) for further assistance. Check carefully to make sure there are no missing or defective parts. Improper installation may cause damage or serious injury. Do not use this product for any purpose that is not explicitly specified in this manual. Do not exceed weight capacity. We cannot be liable for damage or injury caused by improper mounting, incorrect assembly or inappropriate use.



## WARNING: CHOKING HAZARD

SMALL PARTS - NOT FOR CHILDREN UNDER 3 YEARS. ADULT SUPERVISION IS REQUIRED.



## DO NOT EXCEED WEIGHT CAPACITY

FAILURE TO DO SO MAY RESULT IN SERIOUS INJURY.

---

## We're Here for You

Open **Monday - Friday 7:00am - 7:00pm CST**, our dedicated support team can offer immediate assistance with rapid response times. If any parts are received damaged or defective, please contact us. We are happy to replace parts to ensure you have a fully functioning product.



Give us a Call:  
**309-278-5303**

AVG. RESOLUTION TIME (*within office hrs*): **5M 4S**



Chat Us:  
**[www.vivo-us.com](http://www.vivo-us.com)**

AVG. RESOLUTION TIME (*within office hrs*): **< 15 M**



Email Us:  
**[help@vivo-us.com](mailto:help@vivo-us.com)**

AVG. RESPONSE TIME (*within office hrs*): **1HR 8M**

- 23% within < 15m
- 38% within < 30m
- 61% within < 1hr
- 83% within < 2hr
- 92% within < 3hr

# Package Contents

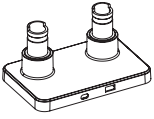

**A (x1)**  
Base

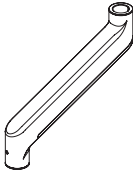

**B (x2)**  
Lower Arm

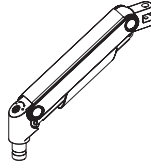

**C (x2)**  
Spring Arm

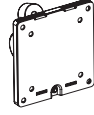

**D (x2)**  
VESDA Adapter

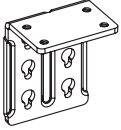

**E (x1)**  
Clamp Brace

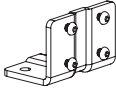

**F (x1)**  
Clamp

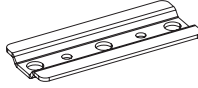

**G (x1)**  
Clamp Plate

---

## Included Hardware & Tools



**S-A (x2)**  
M8 Nut



**S-B (x4)**  
M6x12mm Screw



**S-C (x2)**  
M8x35mm Screw



**S-D (x2)**  
M10x63mm Screw



**M-A (x8)**  
M4x12mm Screw



**M-B (x8)**  
M5x12mm Screw



**M-C (x8)**  
M5 Washer

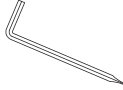

**T-A (x1)**  
4mm Allen Wrench



**T-B (x1)**  
6mm Allen Wrench

---

## Tools Needed:



**Phillips  
Screwdriver**

## Weight Capacity:



**PER ARM**

## ASSEMBLY STEPS

### STEP 1

#### Option 1: Clamp Assembly

Desktop Thickness: 3/8" to 2" (10 - 50mm) or 1.5" to 3" (40 - 80mm)

Attach Clamp Brace (E) to Base (A) using M6x12mm Screws (S-B) and tighten with 4mm Allen Wrench (T-A).

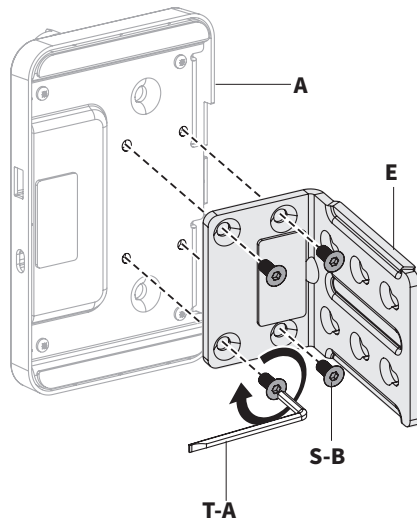

Thread M10x63mm Screws (S-D) into Clamp (F) and place Clamp Plate (G) on top.

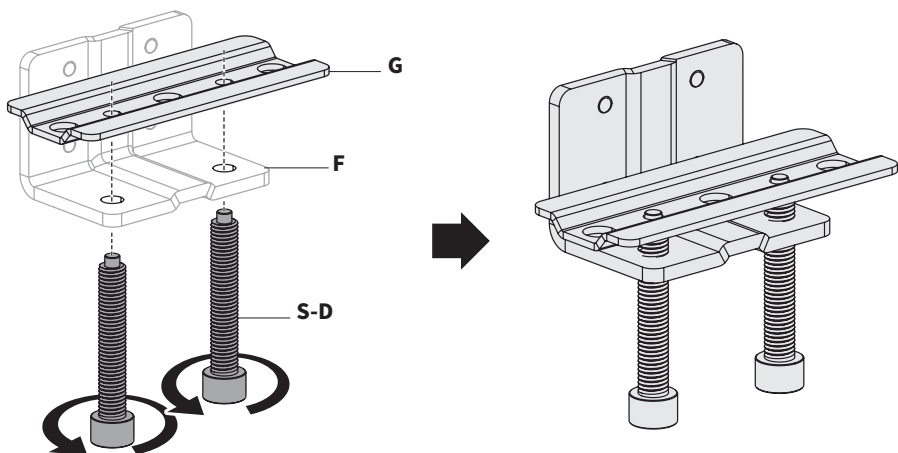

## Option 1 - Clamp [Cont'd]

Loosen bolts on back of Clamp (F) using 4mm Allen Wrench (T-A), leaving 6mm of thread exposed. Hang assembled clamp onto Clamp Brace (E), using guide below to determine location based on desktop thickness.

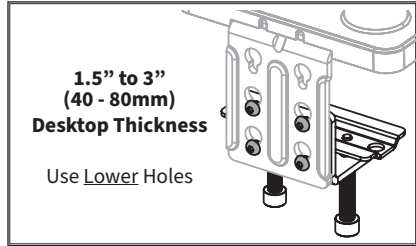
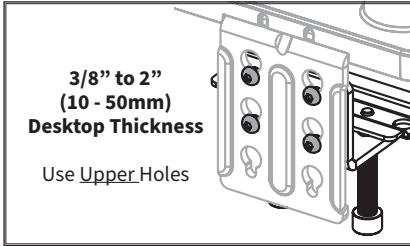
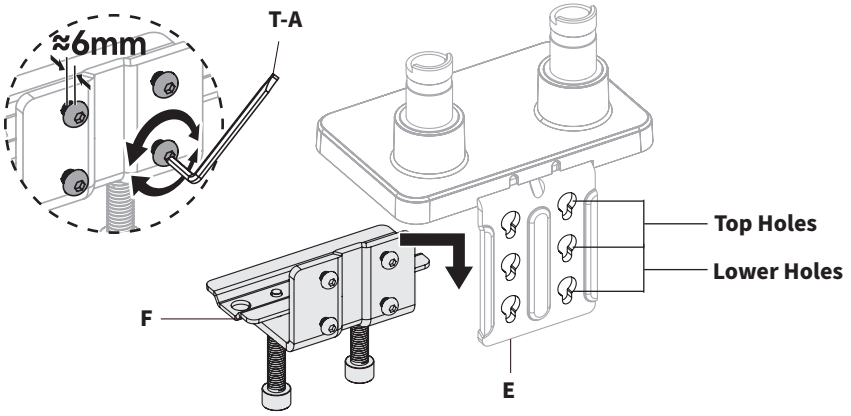

Place assembled clamp on desktop and fully tighten bolts using 4mm Allen Wrench (T-A). Secure clamp to the desktop by tightening previously installed M10x63mm Screws (S-D) using 6mm Allen Wrench (T-B).

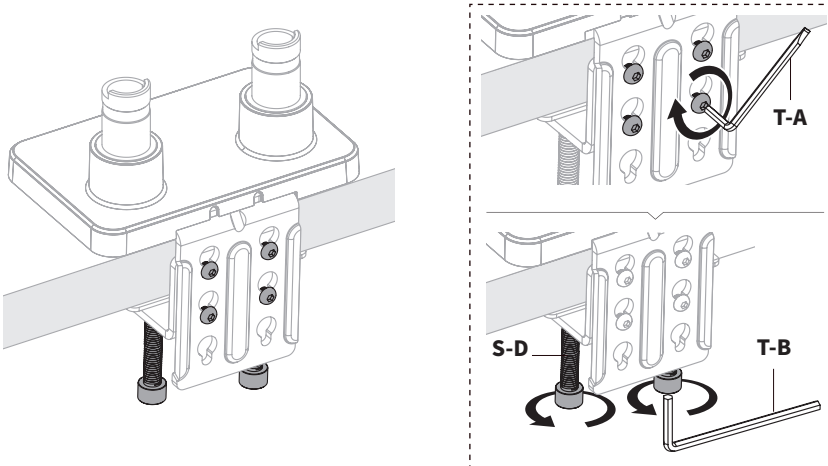

## Option 2: Grommet Mount Assembly

Desktop Thickness: 3/8" to 1 3/8" (10-35mm)

Insert M10x63mm Screws (**S-D**) through Clamp Plate (**G**). Place Base (**A**) over desktop grommet holes and insert M10x63 Screws through hole and tighten to Base using the 6mm Allen Wrench (**T-B**).

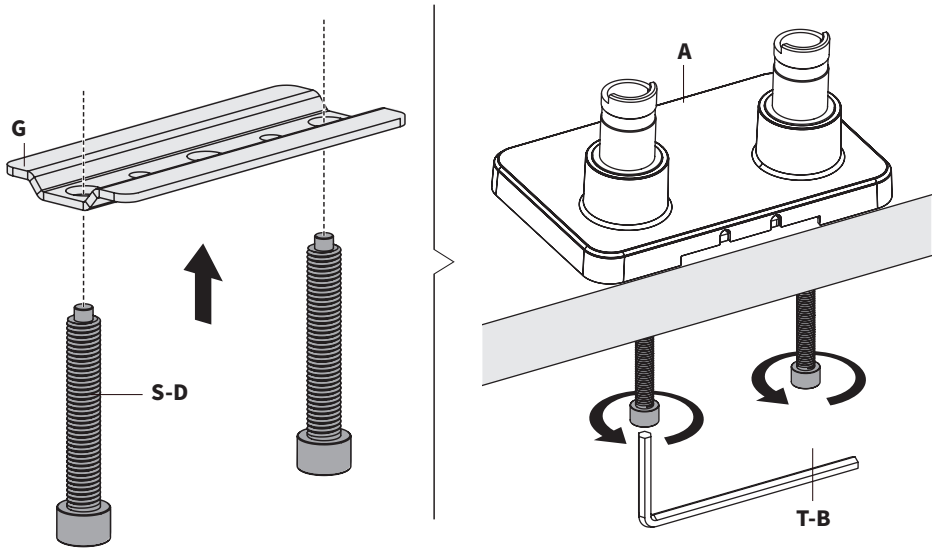

### No Grommet Hole?

If you do not have an existing grommet holes for installation, drill two holes through desktop in your desired mounting location using a 3/8" (10mm) drill bit.

**\*\* READ BEFORE PROCEEDING \*\***

The Monitor Arms can be assembled to have a **Full 360° Rotation** or a **Limited 180° Rotation**. Follow Rotation Instructions below, then pick the rotation option that fits your setup needs.

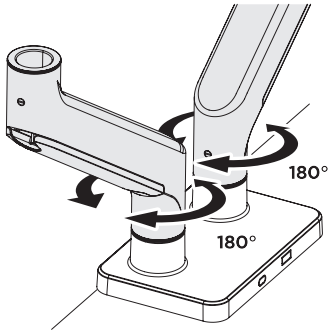

**±180° (360°)  
Full Rotation**

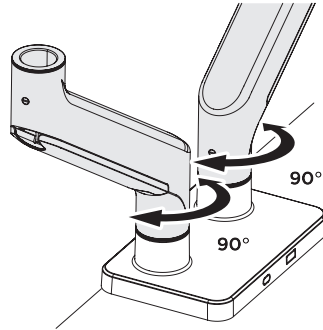

**±90° (180°)  
Limited Rotation**

**Locating Rotation Adjustment Screw**

There is a small **Adjustment Screw** on the underside of Lower Arms (**B**). To locate, turn Arms (**B**) upside down so that the cable sleeves are facing up. There will be a small adjustment screw on the inside of both openings at the bottom.

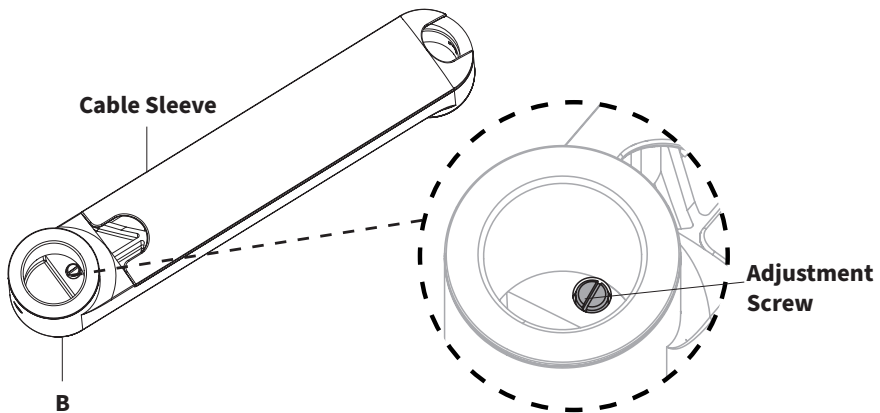

**\*\* Follow Steps on Next Page to Set Rotation by Desired Range \*\***

**±180° (360°)  
Full Rotation**

Fully tighten both Adjustment Screws using the flat end on 4mm Allen Wrench (**T-A**).

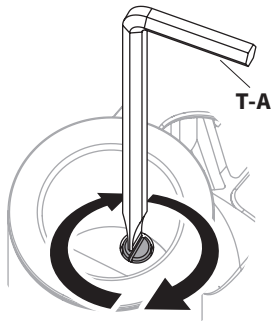

**±90° (180°)  
Limited Rotation**

Loosen both Adjustment Screws using the flat end on 4mm Allen Wrench (**T-A**). The screw should stick out 3/16" [4mm].

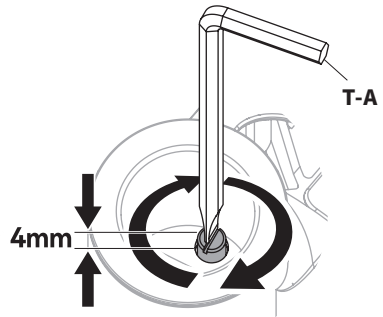

**STEP 3**

Slide Lower Arms (**B**) onto Base (**A**) and tighten the **Set Screws** on the back of both Arms using the flat end of 4mm Allen Wrench (**T-A**) to secure.

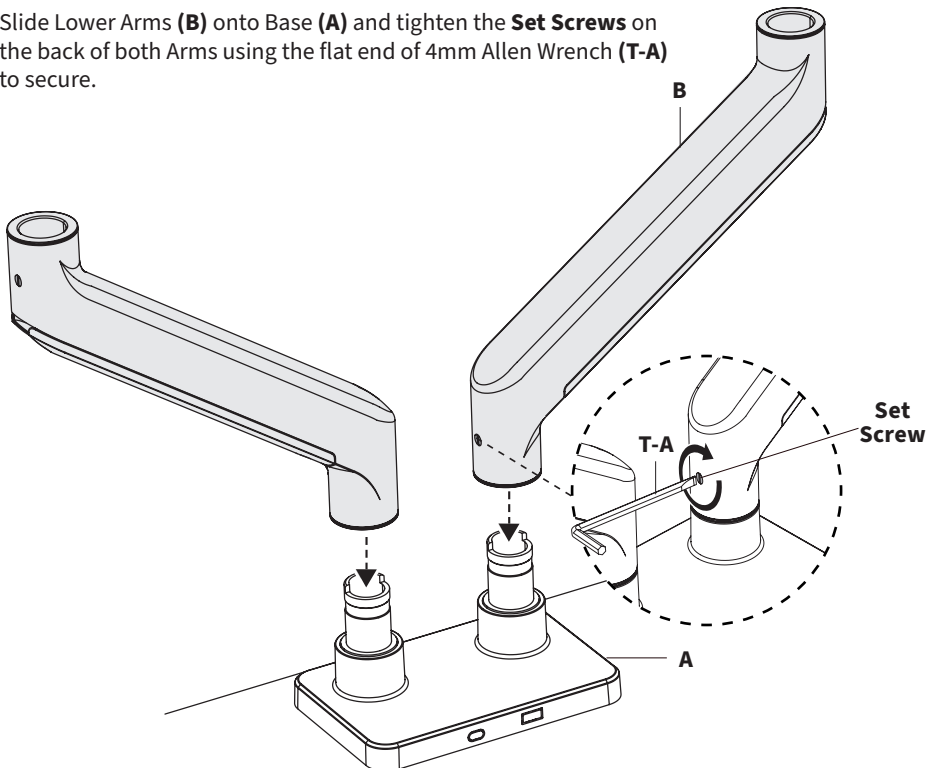

## STEP 4

Place Spring Arms (C) on top of Lower Arms (B), and secure by turning the set screw in back with 4mm Allen Wrench (T-A).

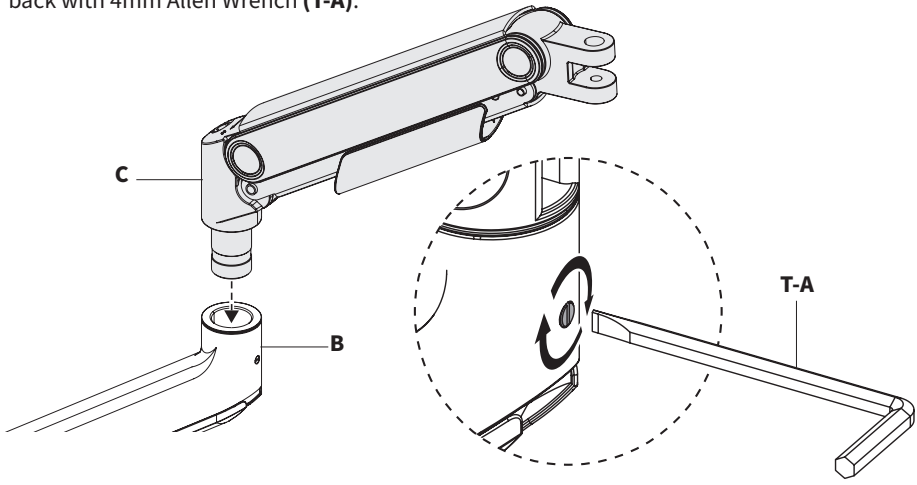

## STEP 5

Attach VESA Adapters (D) using M8x35mm Screws (S-C) and M8 Nuts (S-A) on as Spring Arms (C) using 6mm Allen Wrench (T-B).

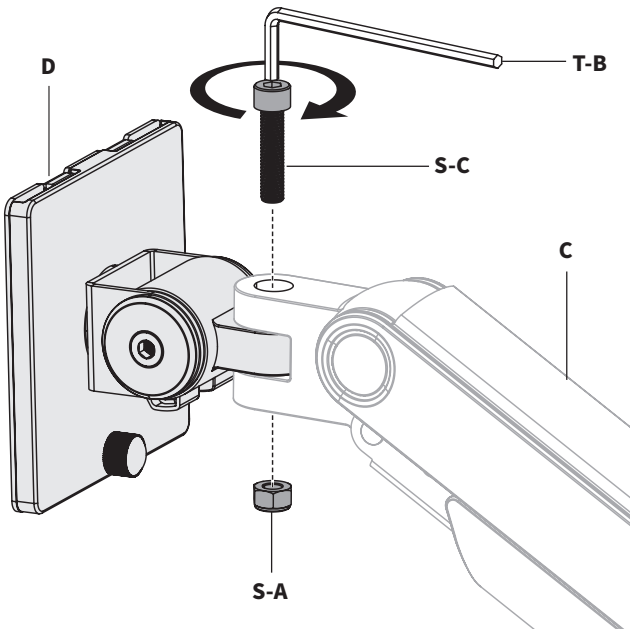

## STEP 6

Unscrew Thumbscrews (**D1**) on VESA Adapters (**D**) and remove VESA Plates (**D2**).

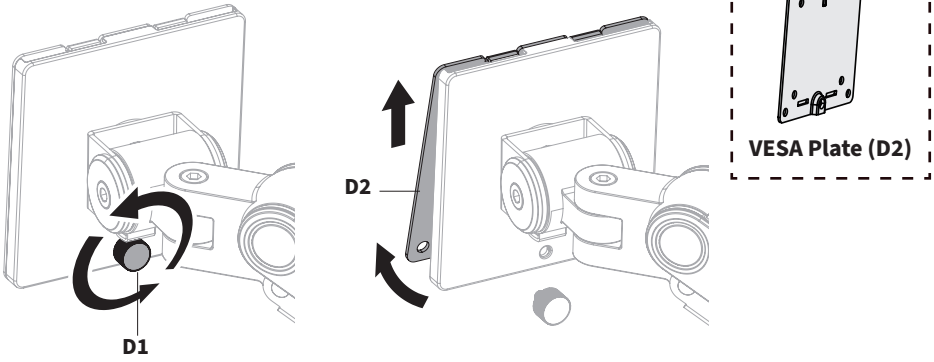

Install the VESA Plates (**D2**) to monitors using M4x12mm Screws (**M-A**) or M5x12mm Screws (**M-B**) with M5 Washers (**M-C**), making sure the arrow in back is pointing up.

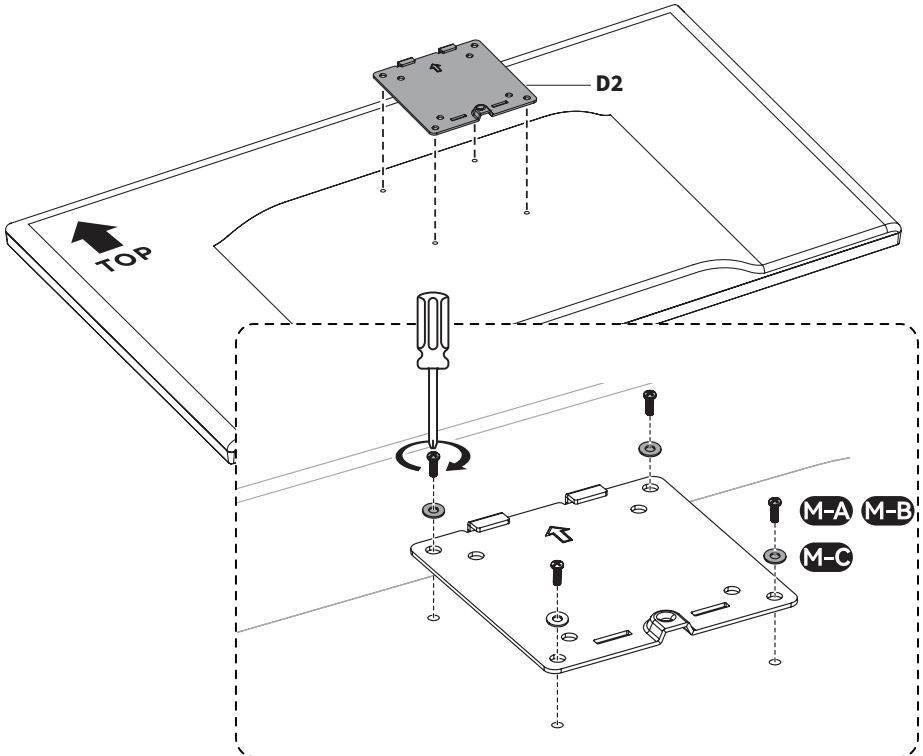

## Adjusting the Tilt Joint

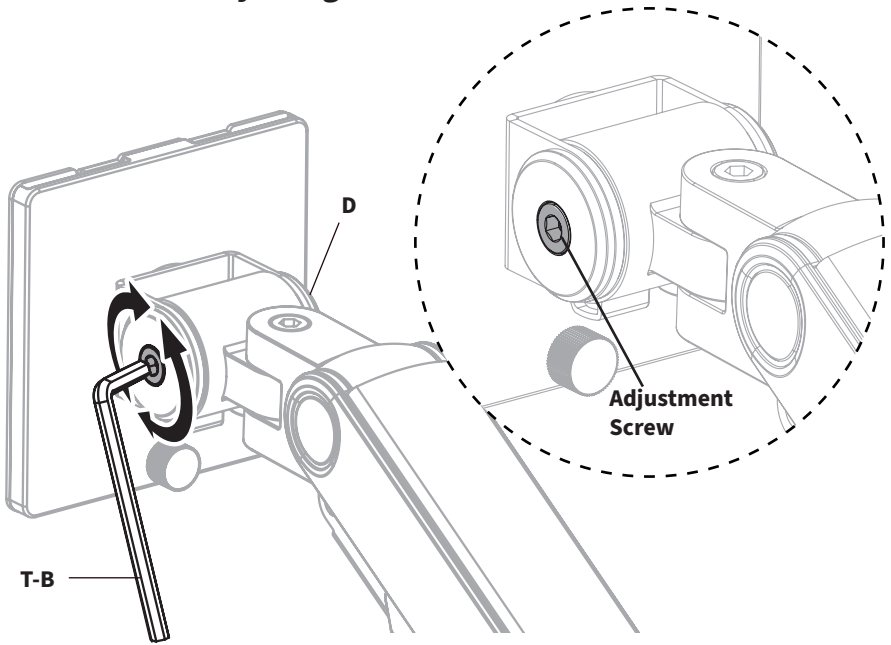

### 1 Loosen Tilt Joint:

Use 6mm Allen Wrench (T-B) to loosen the tilt joint **Adjustment Screw**, located on the side of VESA Bracket (D).

### 3 Lock Angle

Tighten as much as possible using the 6mm Allen Wrench (T-B) to lock the angle.

### 2 Set Angle

Firmly grip the VESA Bracket and adjust to your desired viewing angle, and hold in place.

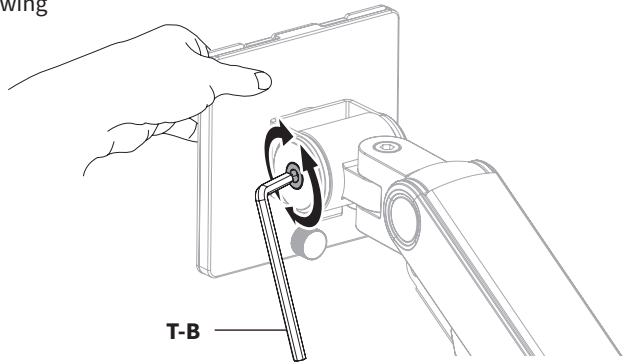

**\*Firmly hold VESA Bracket in place while adjusting tilt angle.**

With the assistance of a second person, line up the VESA Plate (**D2**) on your monitor with the VESA Bracket (**D**) and the Plate Hooks into the pockets of the VESA Bracket.

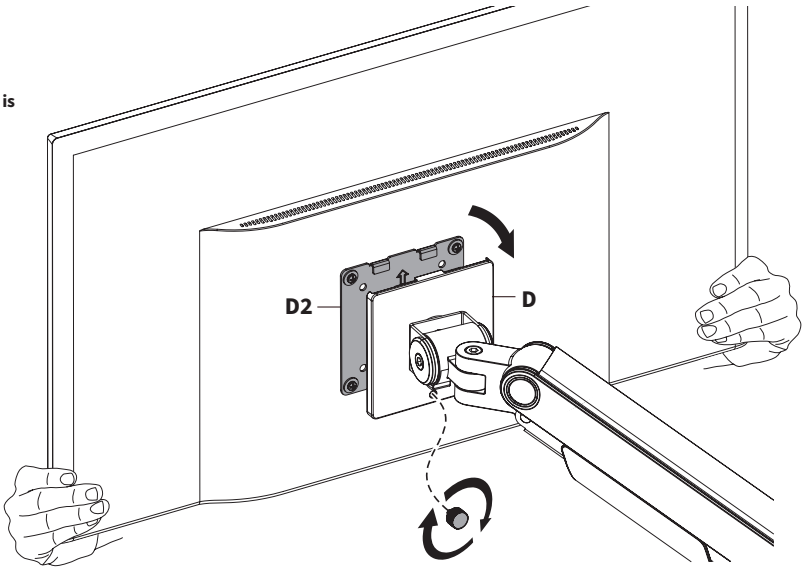

*\*Monitor & VESA Bracket may need to be angled backwards slightly when sliding on.*

Gently release the monitor and secure using the previously removed Thumbscrew (**D1**).

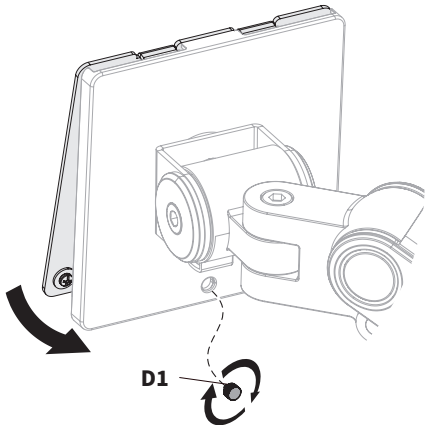

**Monitor Tilted Too Far?**

**\*\* See Next Step \*\***

Refer to instructions in next step to adjust. **DO NOT** try to adjust angle freely. Doing so may result in accidental damage to your screen.

## Fine Tune Tilt Angle

*If the monitor is angled further than intended...*

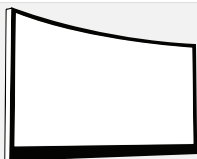

### Heavy Weighted/ Ultrawide Monitors

[ 22lbs - 44lbs ]

- 1 Firmly Hold Monitor**  
Firmly grasp and hold the monitor in place. Do NOT release monitor until you have completed steps below.
- 2 Loosen Tilt Joint:**  
With a hand still on the monitor, use 6mm Allen Wrench (**T-B**) to loosen the tilt joint **Adjustment Screw**, located on the side of VESA Bracket (**D**).
- 3 Set & Lock Angle**  
Adjust screen slightly past your desired viewing angle, then tighten the screw as much as possible using 6mm Allen Wrench (**T-B**).
- 4 Straighten Angle**  
Slowly adjust the monitor down until your desired angle is reached. Release monitor and check angle. Repeat process as necessary

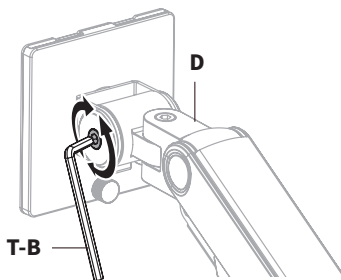
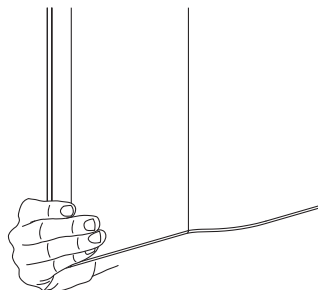

2 Person  
Adjustment is  
Recommended

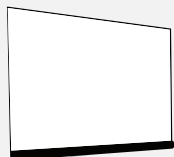

### Ultra Thin Monitors



#### **ALWAYS REMOVE MONITOR BEFORE RE-ADJUSTING**

To prevent accidental damage to your screen, remove monitor and then follow Tilt Adjustment instructions. Reinstall monitor when desired angle is reached.

## Adjusting Monitor Height

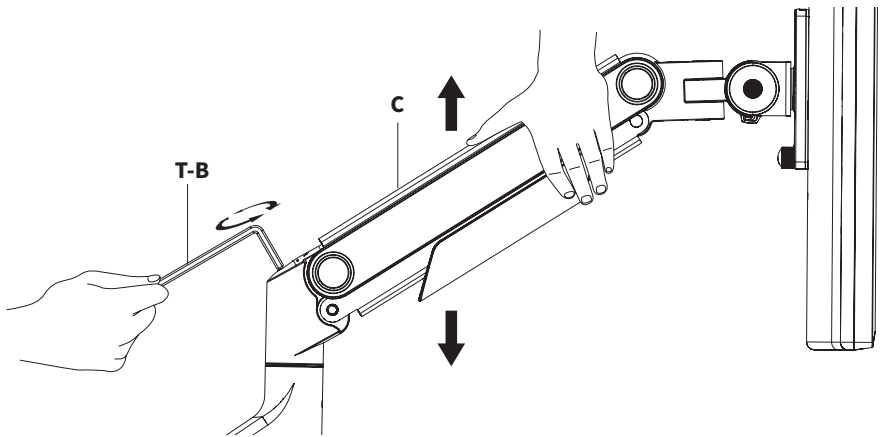

### 1 Position Mount Arm

Position the arm horizontally, as shown above, and firmly hold in place.

### 2 Insert 6mm Allen Wrench (T-B) Into Adjustment Screw

Insert the 6mm Allen Wrench (T-B) in to the adjustment screw on the back of the monitor arm.

### 3 Turn 10-20x to Set Monitor Height

Turn 6mm Allen Wrench (T-B) 10-20 times to obtain proper support for your monitor. Use the guide below to adjust the tension according to the amount of counterbalance needed to support the monitor.

## Tension Adjustment Guide

**Clockwise:**  
**Increase Support**  
*[if monitor will not raise]*

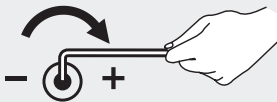

Turn the adjustment screw **clockwise** to **increase** the support for your monitor, allowing it to be raised.

**Counter-Clockwise**  
**Decrease Support**  
*[if monitor will not lower]*

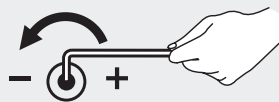

Turn the adjustment screw **counter-clockwise** to **decrease** the support for your monitor, allowing it to be lowered.

**Note: Requires 10-20 Turns**

## STEP 9

Remove cable covers on Spring Arms (**C**) by pulling the sides away from the arm to unclip them. Slide cable covers on Lower Arms (**B**) forward to remove them. Manage cables in cable covers and re-install.

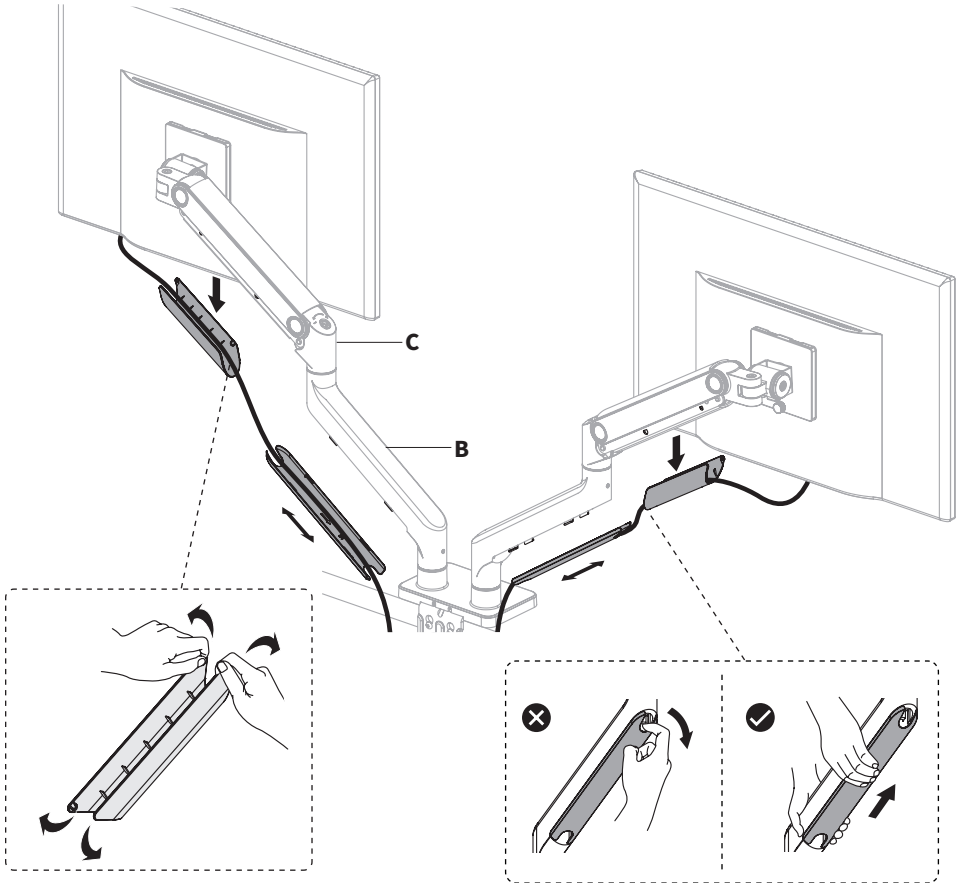

## Adjust as Desired

Adjust swivel using 6mm Allen Wrench (T-B).

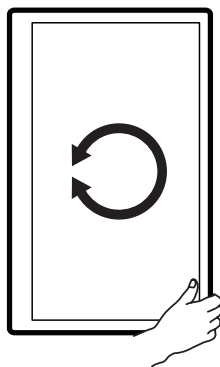
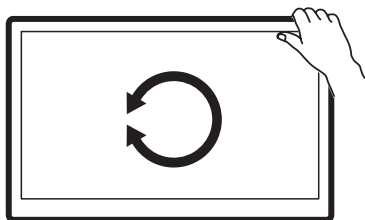
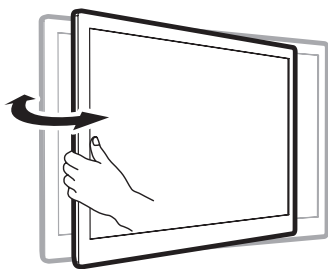
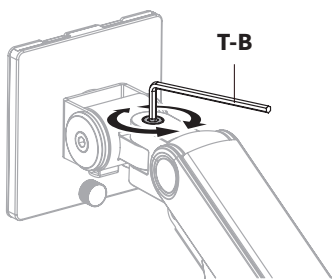

 **WARNING** 

Ensure the display is always positioned over the desk surface to prevent damage.

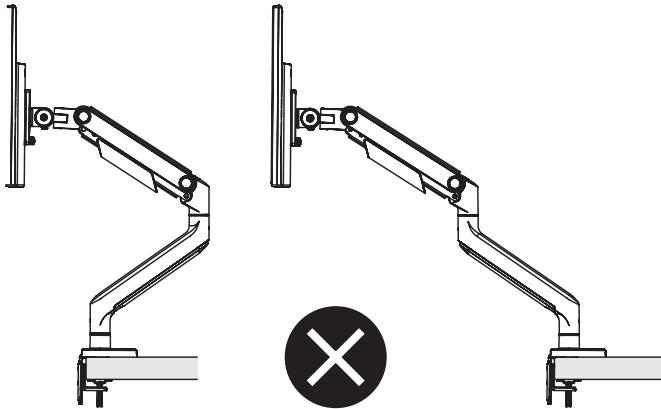
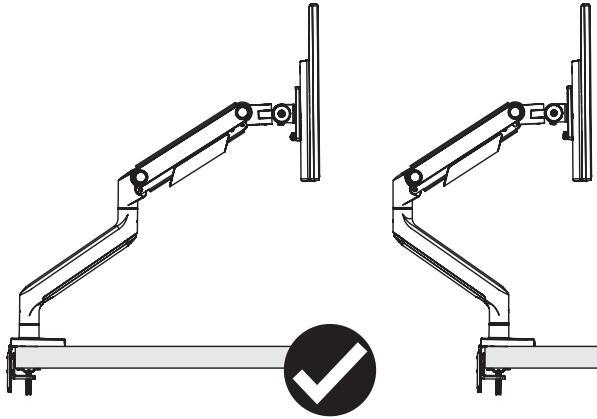

[ THIS PAGE HAS BEEN INTENTIONALLY LEFT BLANK ]



## **Need Help? Get In Touch**

Monday-Friday from 7:00am-7:00pm CST



[help@vivo-us.com](mailto:help@vivo-us.com)



[www.vivo-us.com](http://www.vivo-us.com)

*Chat live with an agent!*



309-278-5303



**VIVO-us @vivo\_us**

FOR MORE GREAT VIVO PRODUCTS,  
CHECK OUT OUR WEBSITE AT: [WWW.VIVO-US.COM](http://WWW.VIVO-US.COM)