

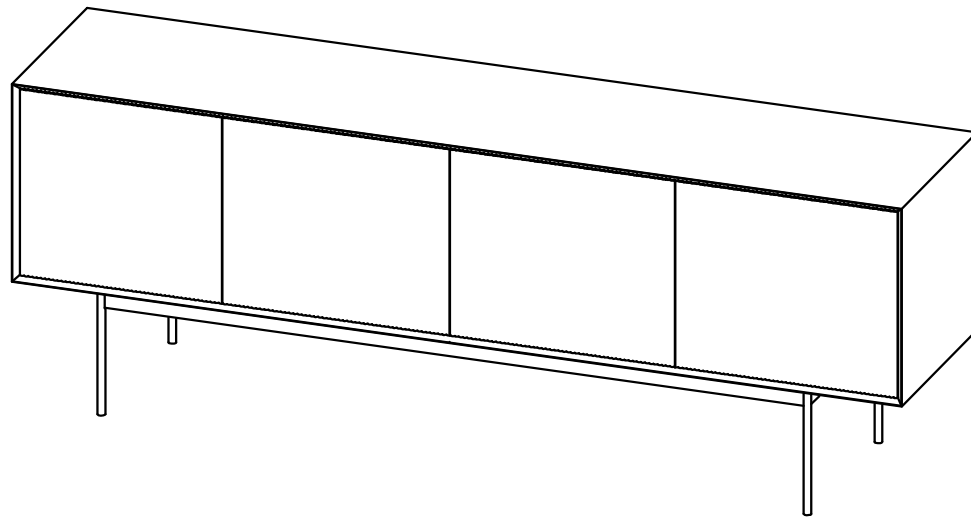

ASSEMBLY INSTRUCTIONS



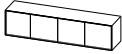

THANK YOU FOR YOUR PURCHASE!

PARTS AND HARDWARE.

PARTS LIST

No.	DESCRIPTION	IMAGE	Q'TY
P1	BODY		1
P2	METAL LEGS		1

HARDWARE LIST

No.	DESCRIPTION	IMAGE	Q'TY
H1	BOLT(M6*15)		5
H2	FLAT WASHER(Ø13*Ø7*1)		5
H3	ALLEN KEY		1

NOTES.

Thank you for purchasing this quality product! Be sure to check all packing material carefully for small part that may have come loose inside the carton during shipping.

CAUTION:The item is heavy, assembly should be performed by two people.

STEP 1.

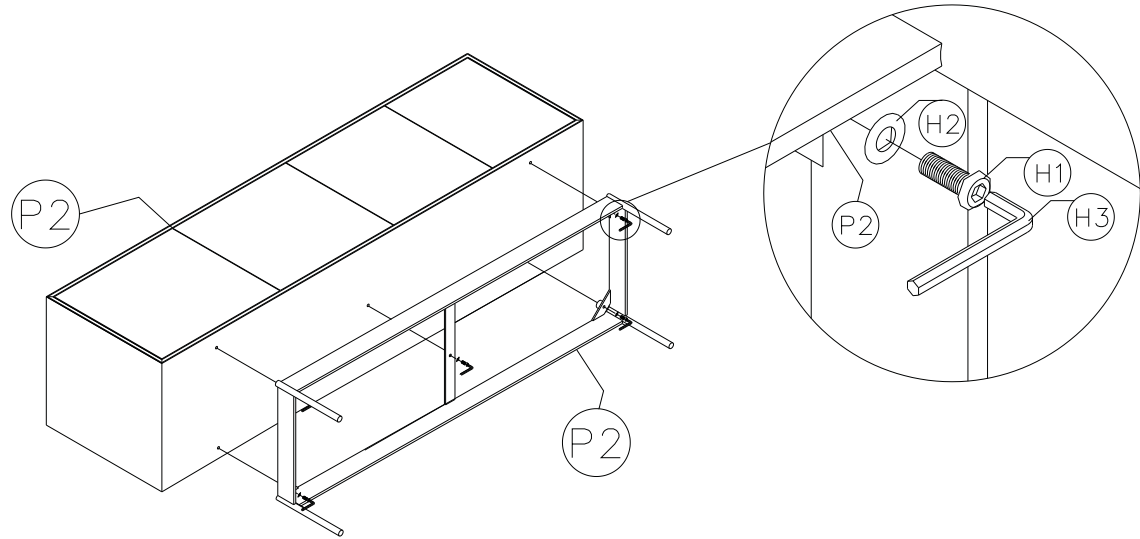

STEP 2.

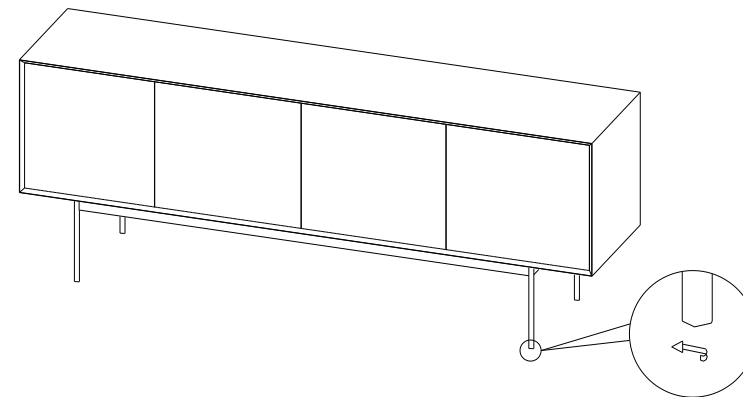

Adjust leveler for stable