

ASSEMBLY INSTRUCTION

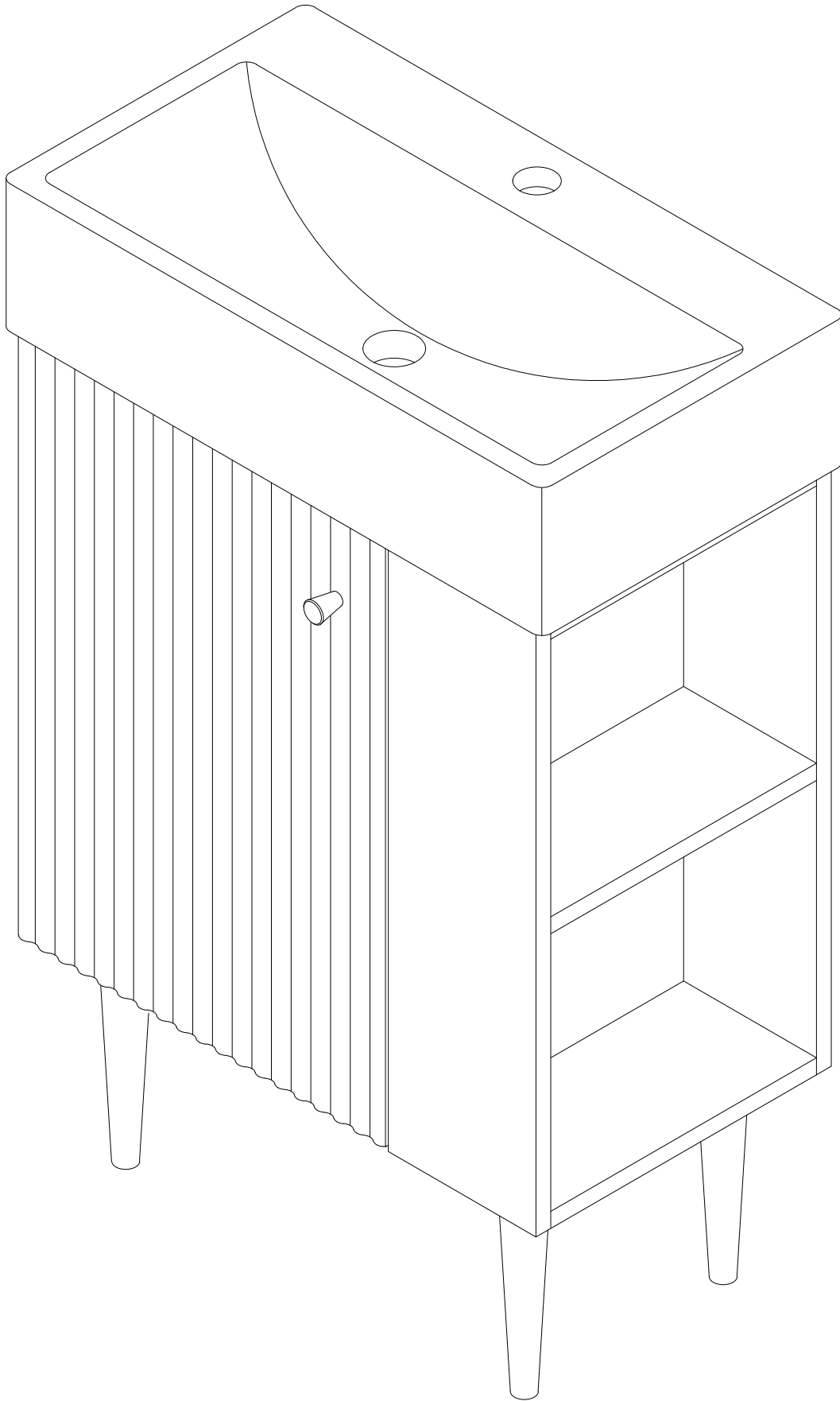

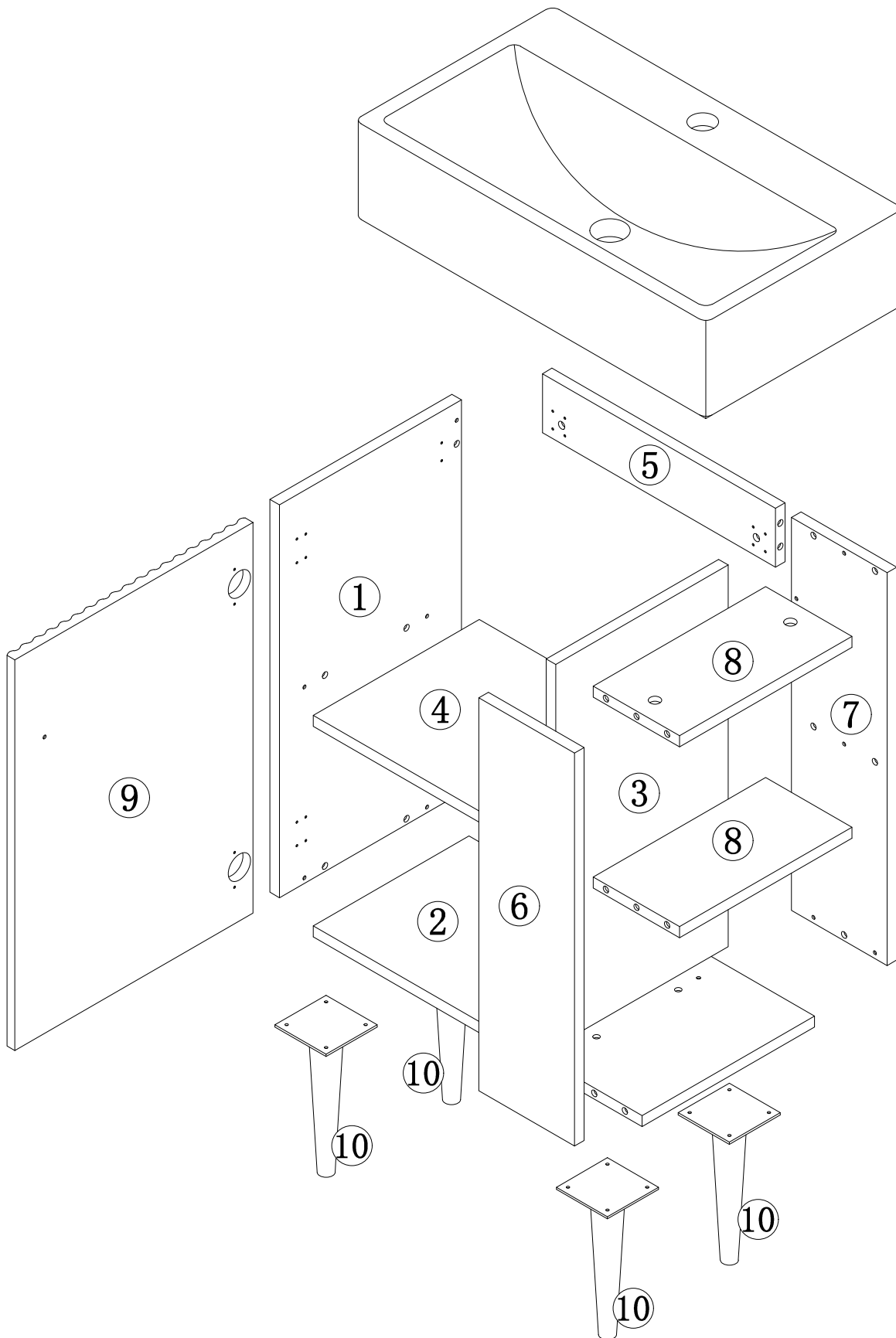

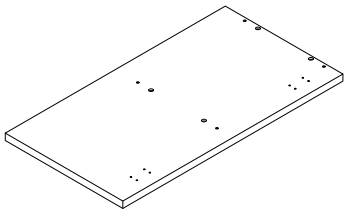

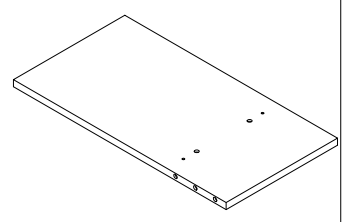
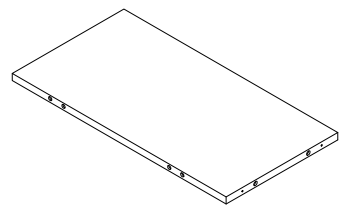
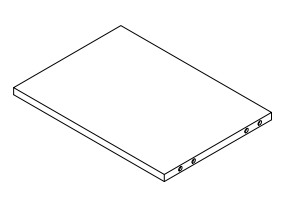
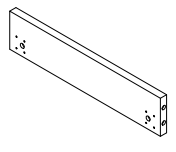
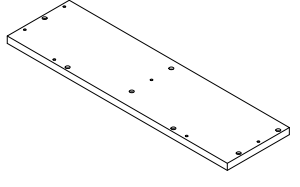
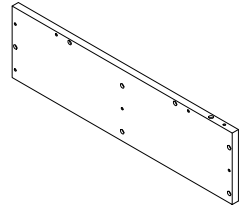
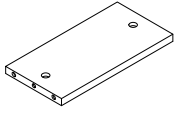
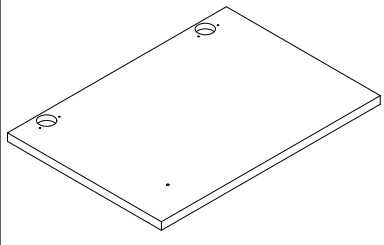
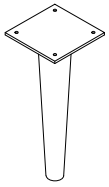

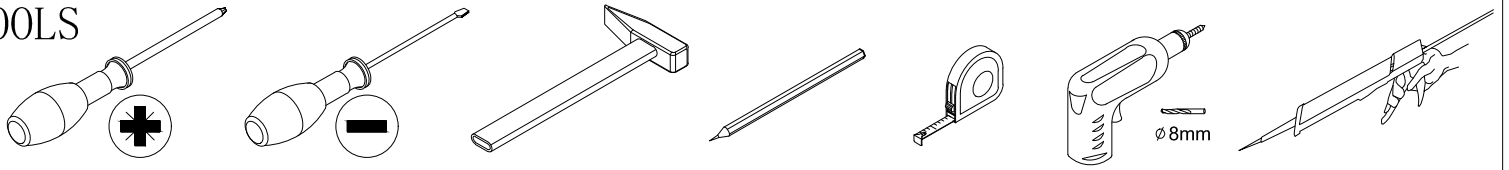

ASSEMBLY INSTRUCTION

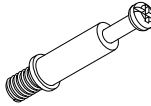

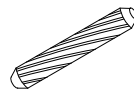
			
① x1	② x1	③ x1	④ x1
			
⑤ x1	⑥ x1	⑦ x1	⑧ x2
			
⑨ x1	⑩ x4		

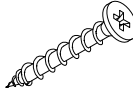
TOOLS

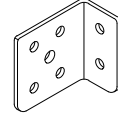
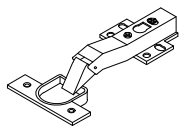

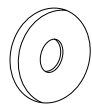
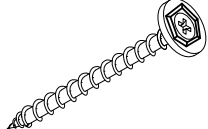
A * 16	B * 16	C * 24	D * 12	E * 28
				
M6 X 35mm	Ø15 x 12mm	Ø8 x 30mm	M4 x 14mm	M4 x 14mm
F * 6	G * 1	H * 1	I * 2	J * 2
				
M5 x 40mm	M4 x 20mm			Ø35
K * 2	L * 2	M * 2		
				
Ø8 x 40mm	Ø20	M6 x 60mm		

Step 1

A * 16

E * 4

J * 2



M6 X 35mm



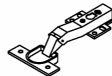

M4 x 14mm

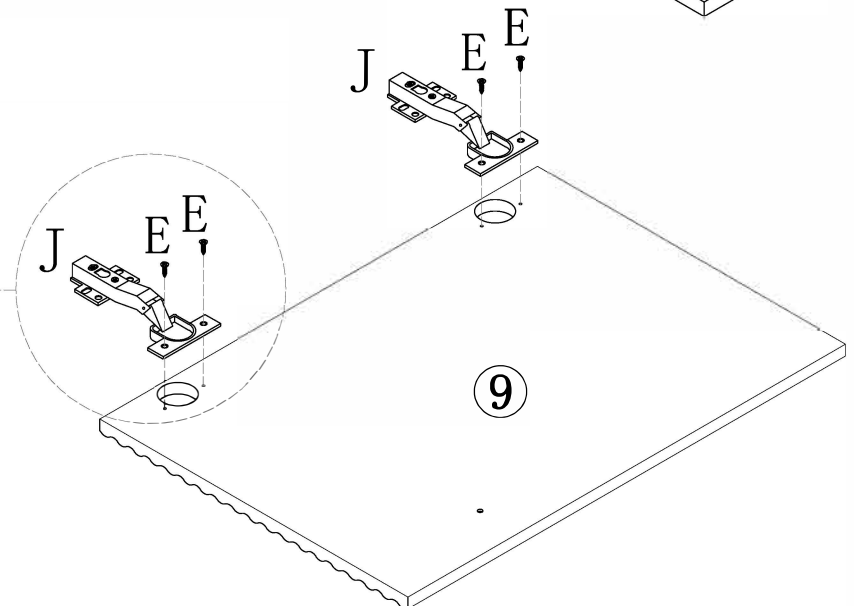
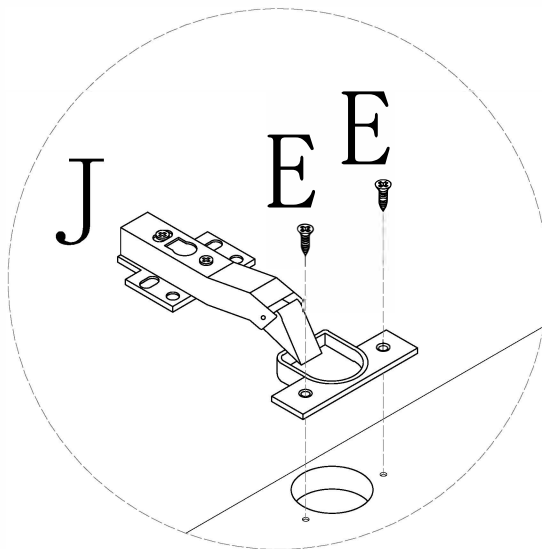
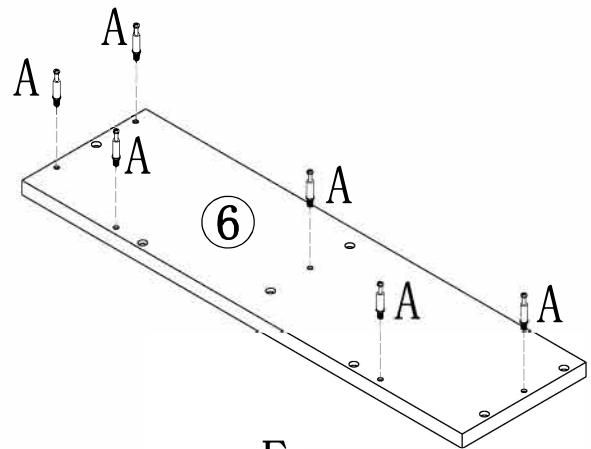
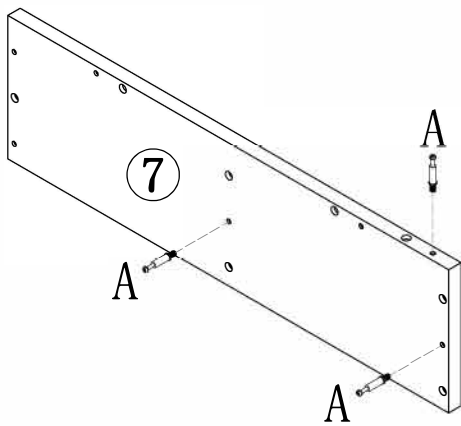
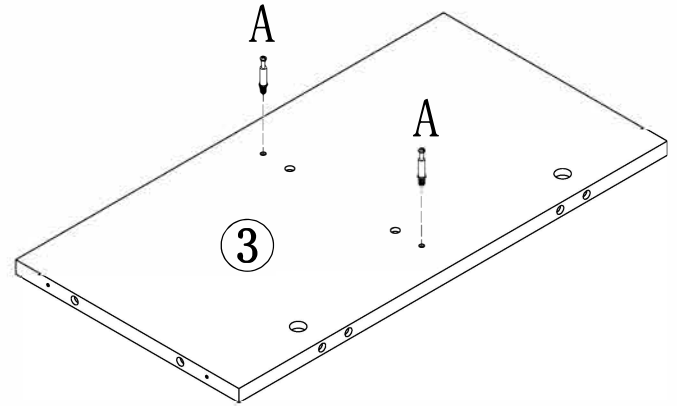
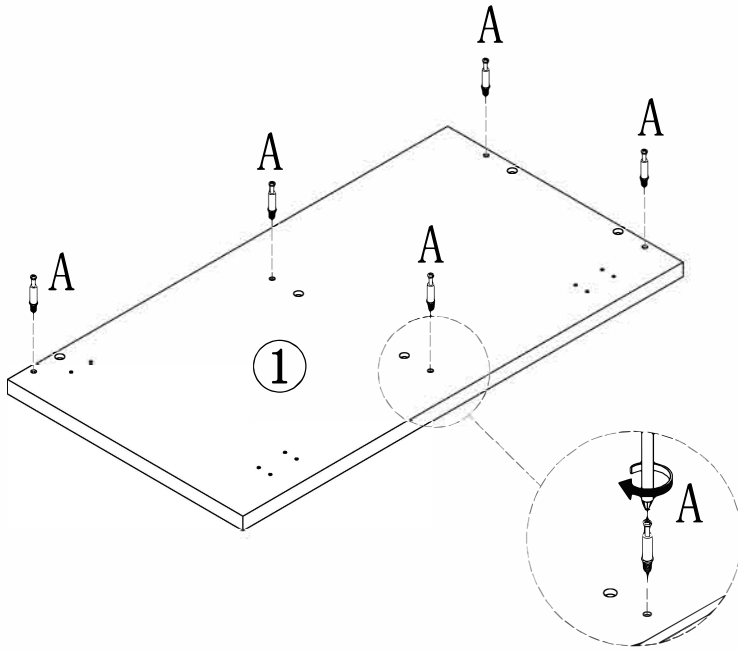
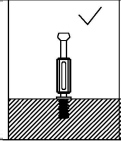
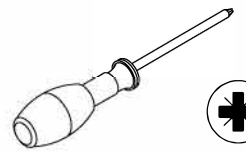

Ø35



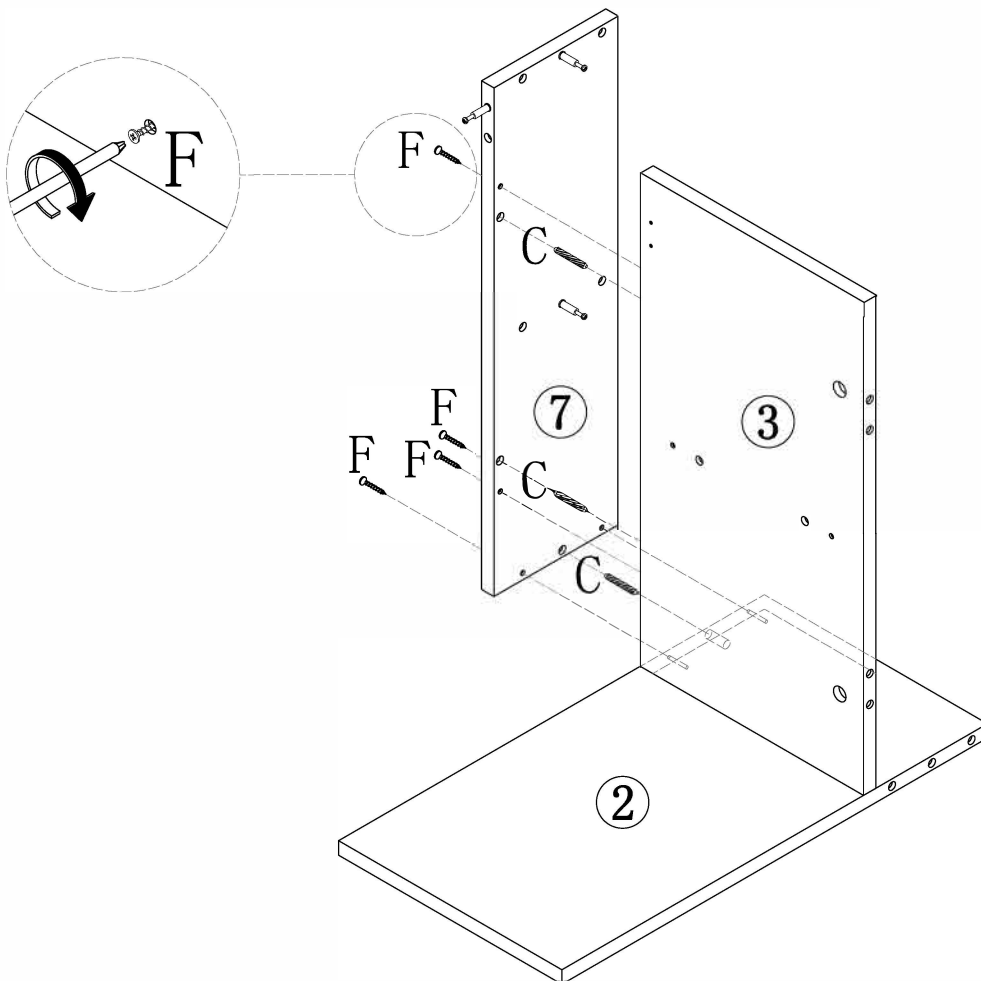
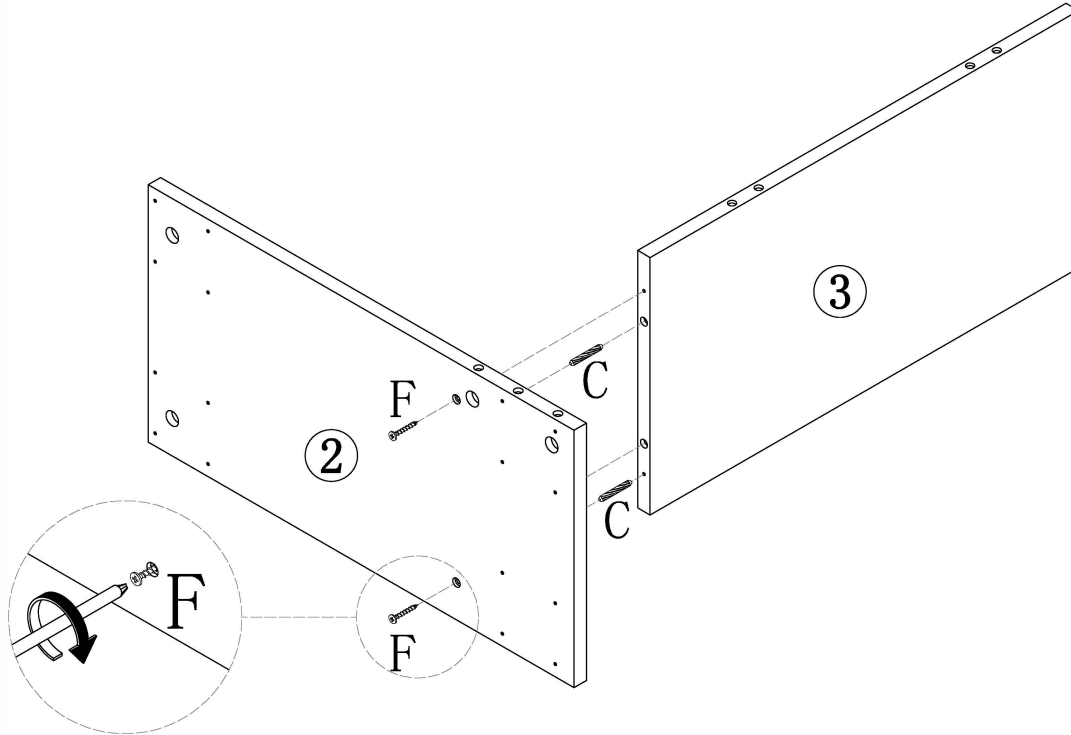
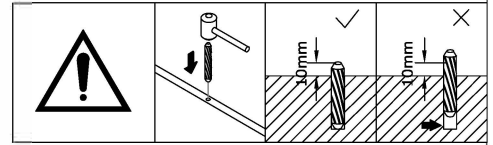
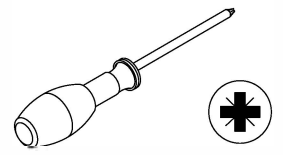

Step 2

C * 5	F * 6
 Ø8 X 30mm	 M5 X 40mm



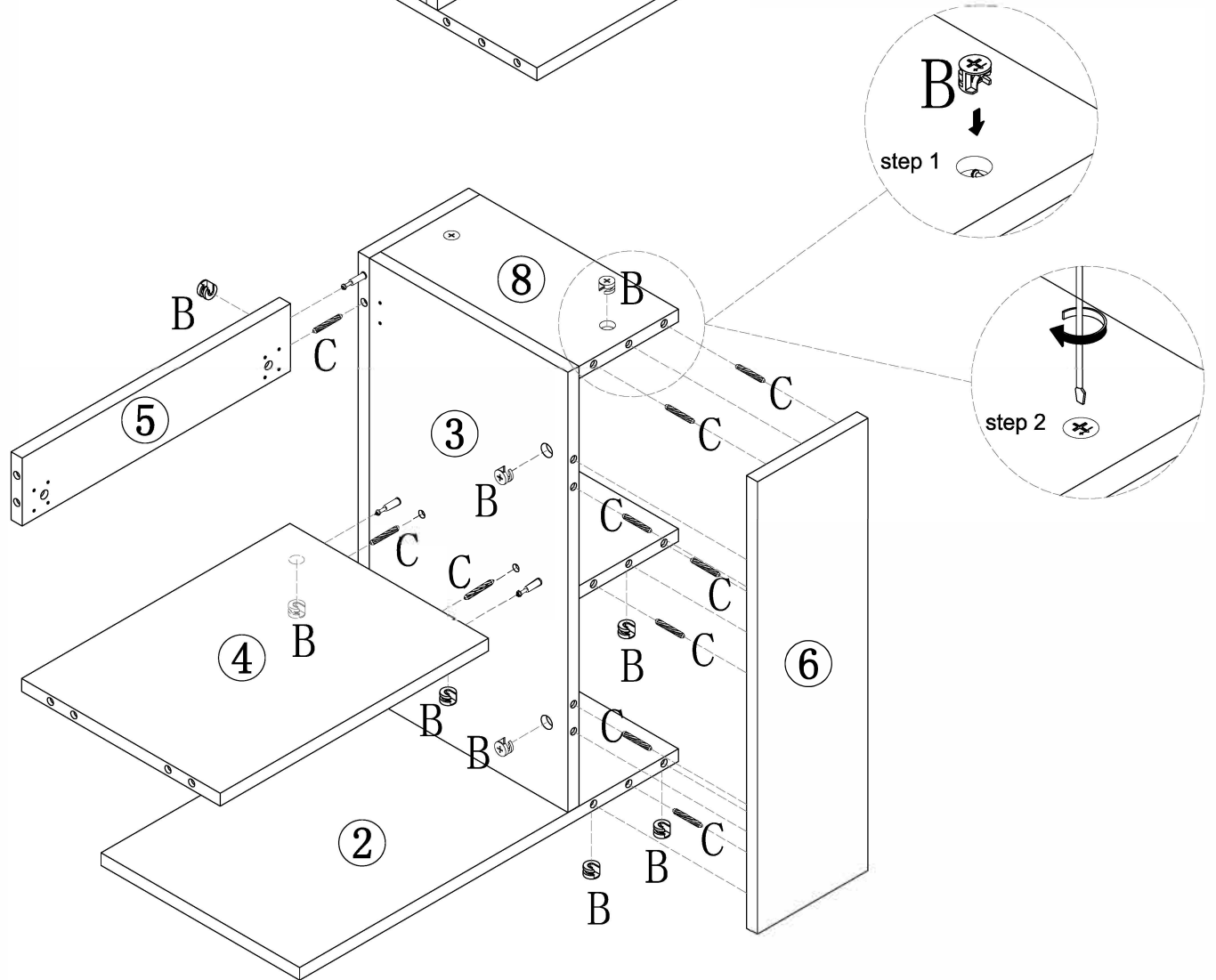
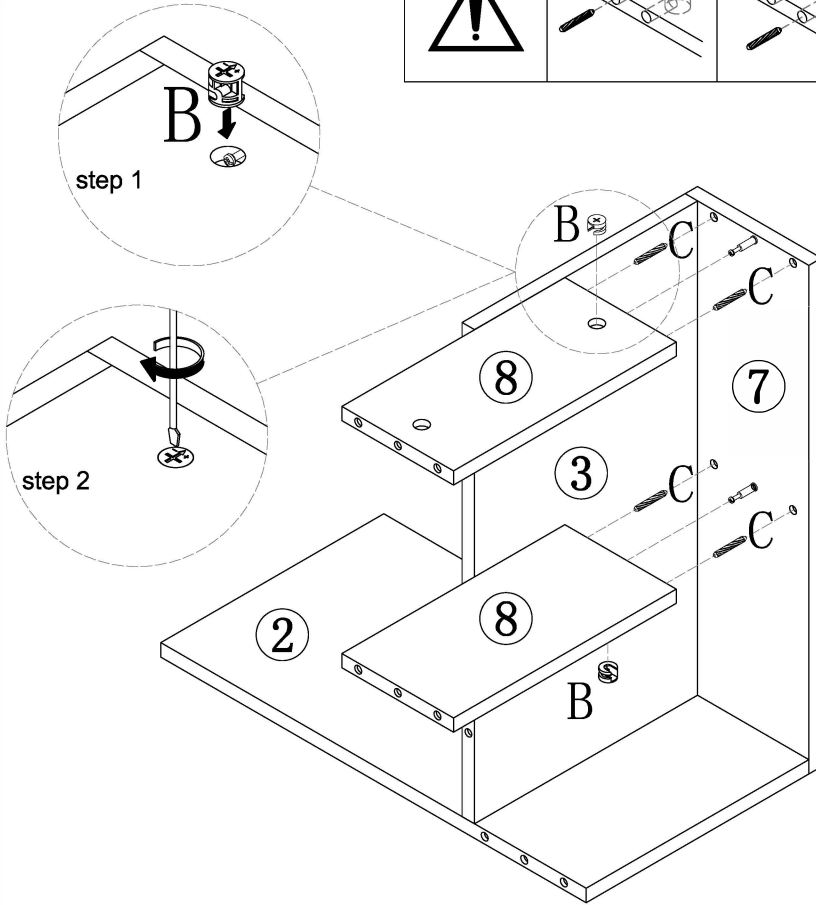
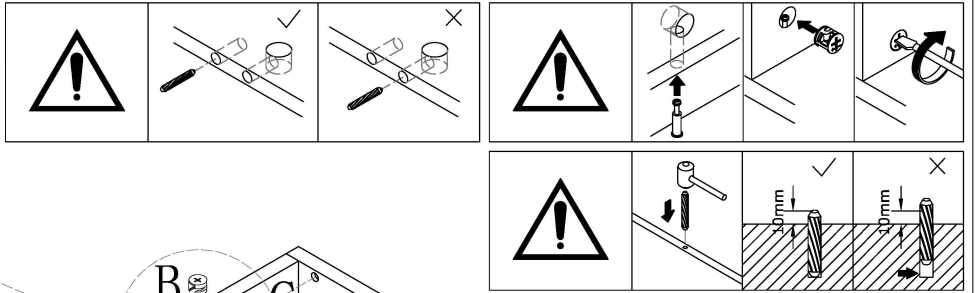
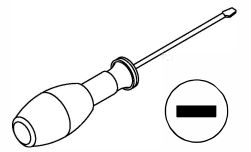

Step 3

B * 11	C * 14
	
Ø15 x 12mm	Ø8 x 30mm



Step 4

B * 5

Ø15 x 12mm

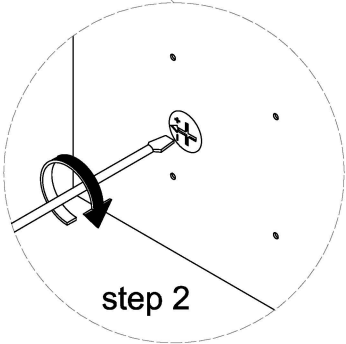
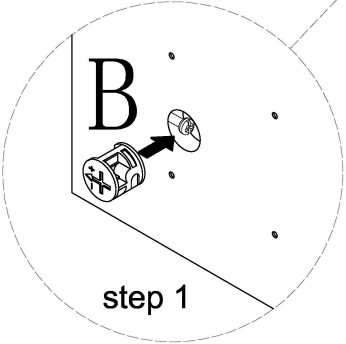
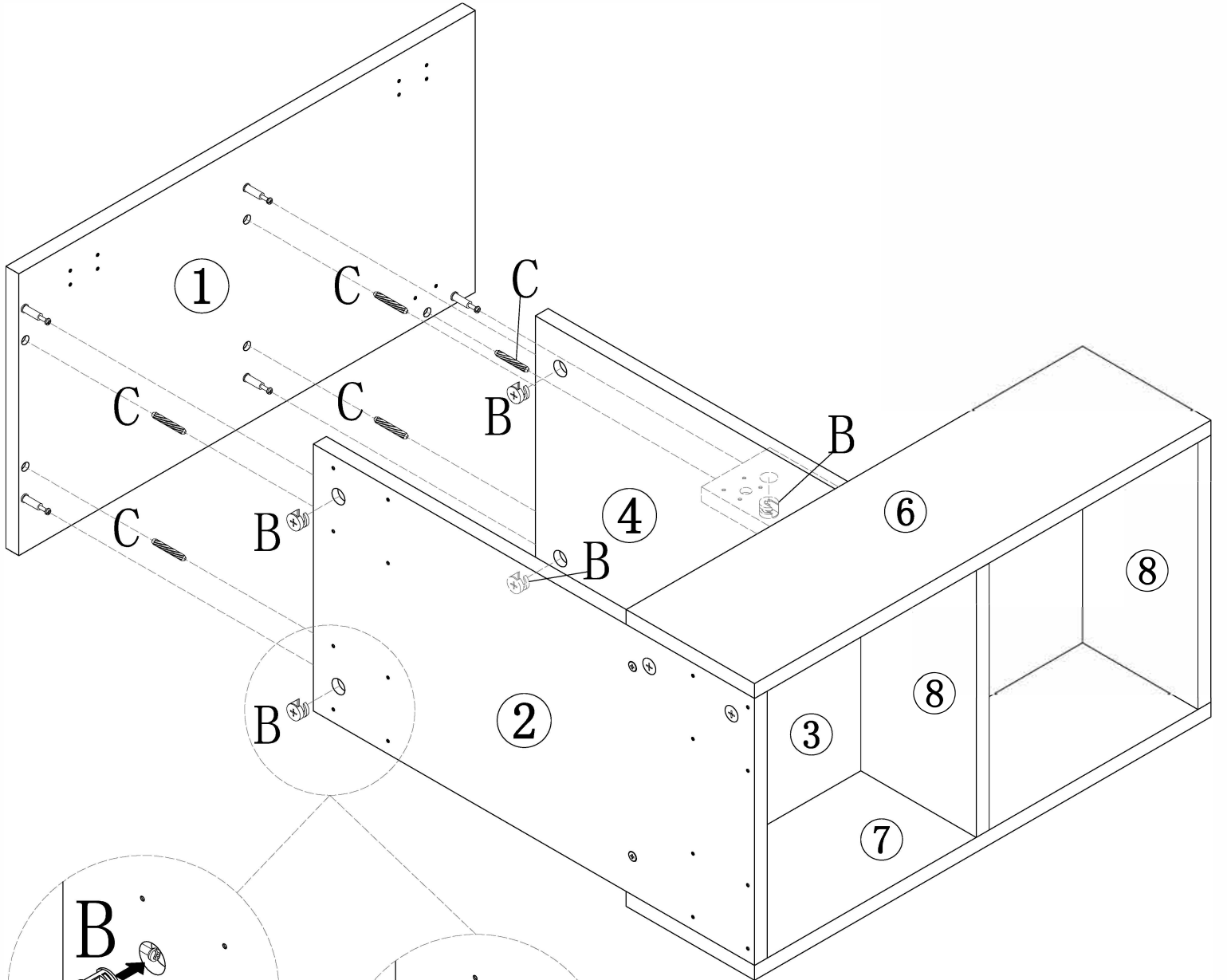
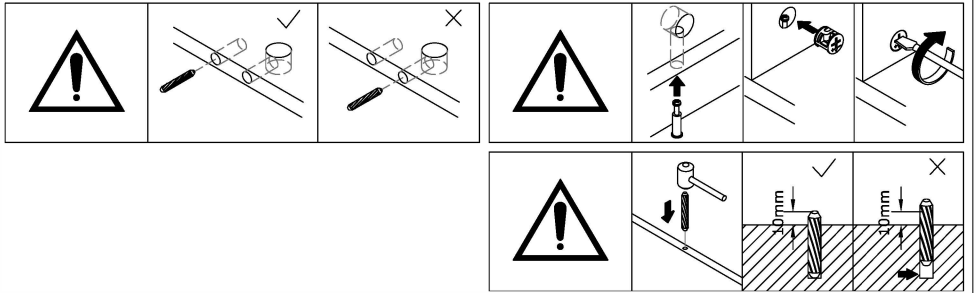
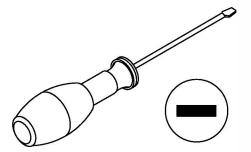
C * 5

Ø8 x 30mm



Step 5

E * 16



M4 x 14mm

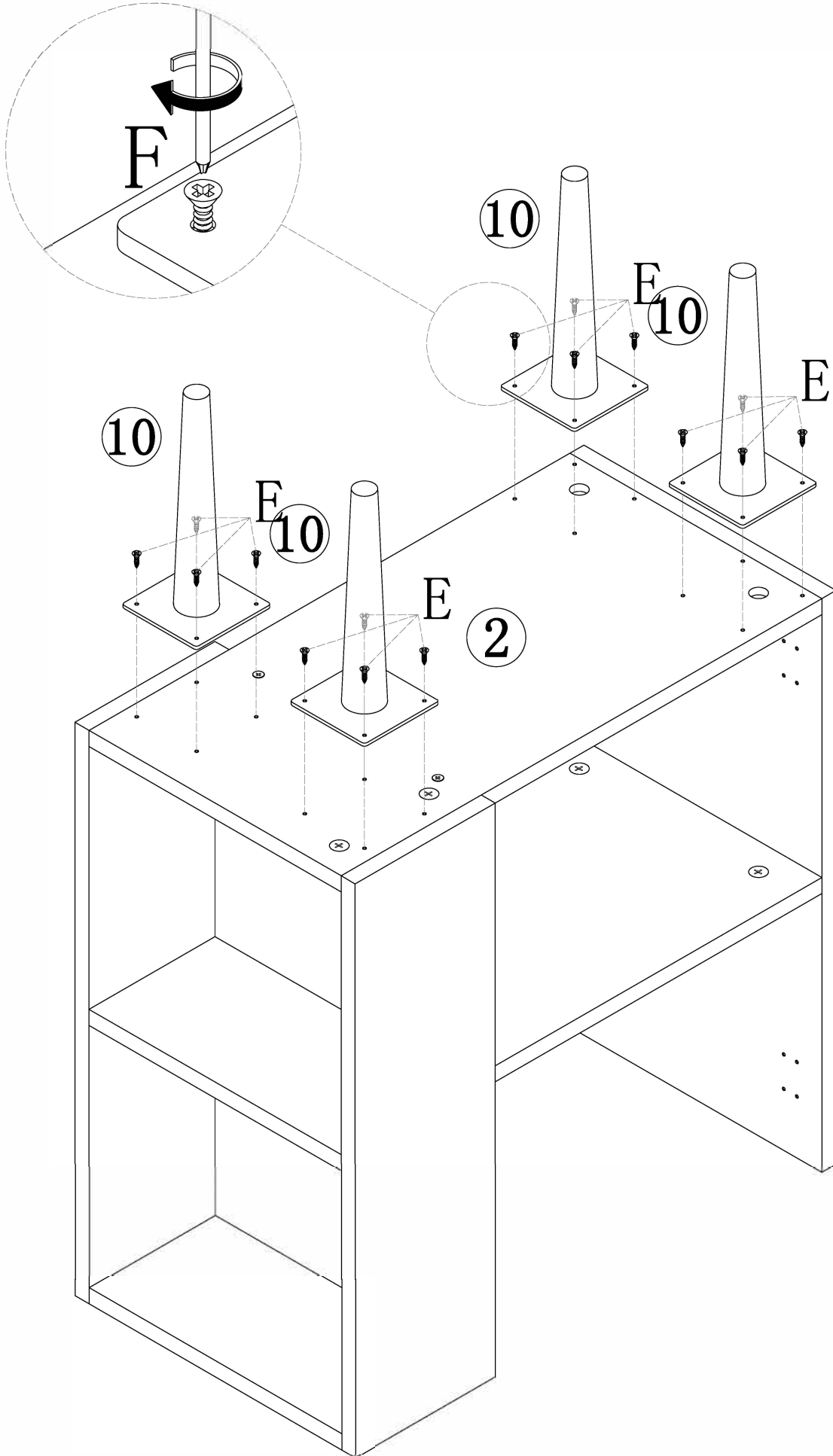
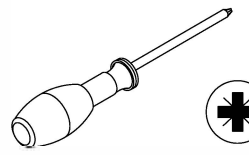

Step 6

D * 12

I * 2



M4 x 14mm

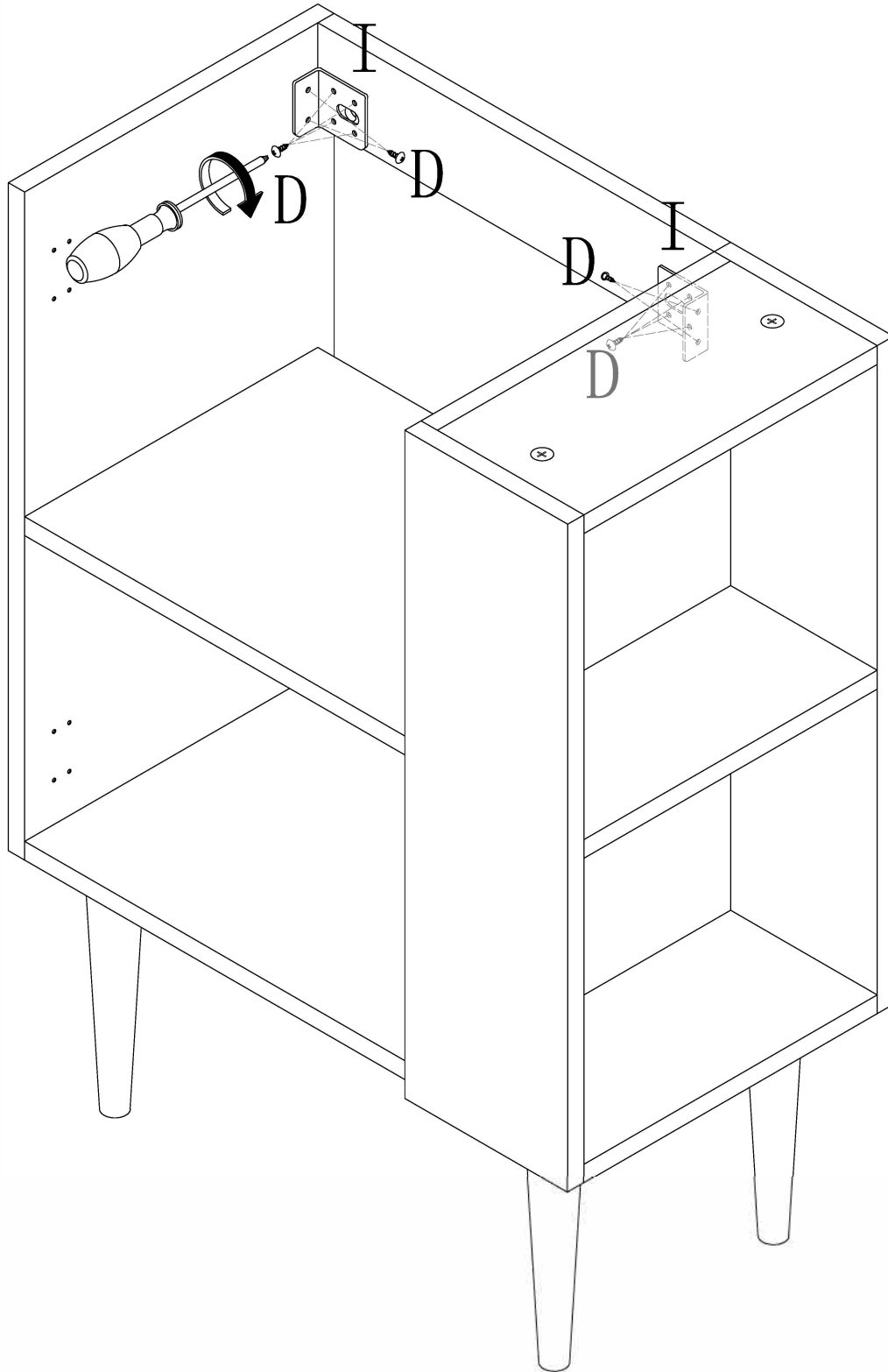
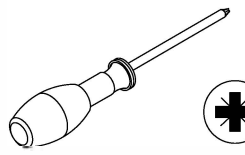

Step 7

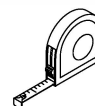

Wall

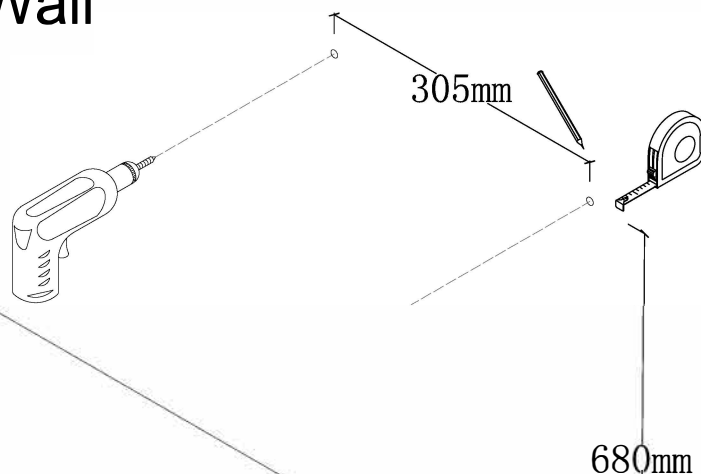

Please mark the location on the wall with a pencil, then punch the hole

Step 8

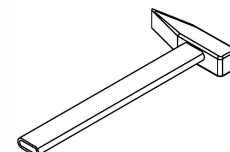

K * 2

Ø8 x 40mm

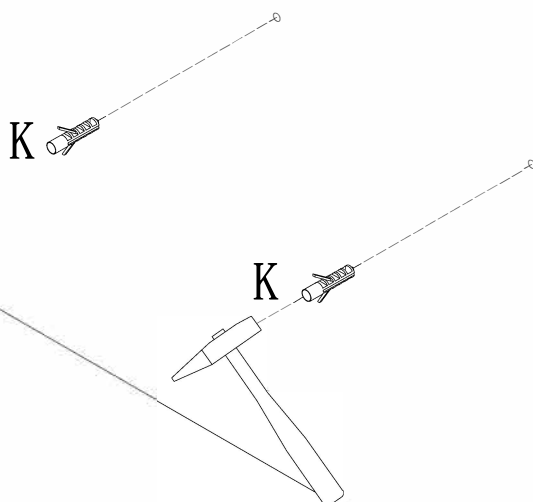

Wall



Step 9

L * 2	M * 2
 Ø16	 M6 x 60mm

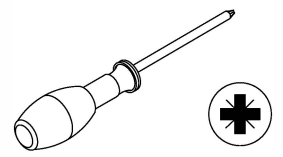

Wall

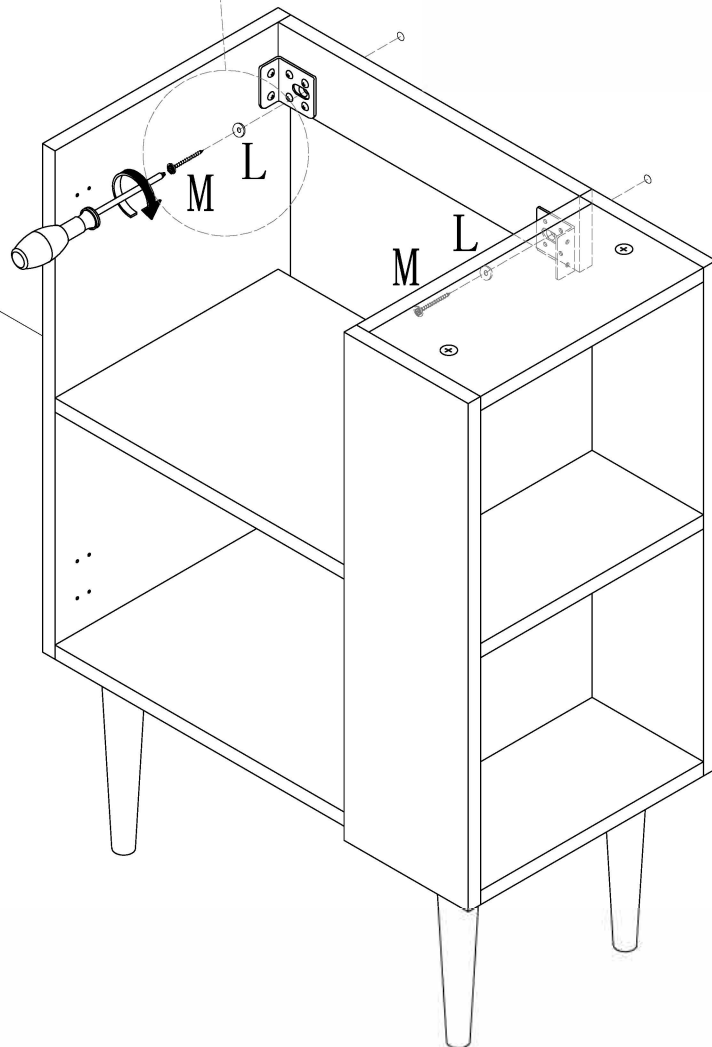
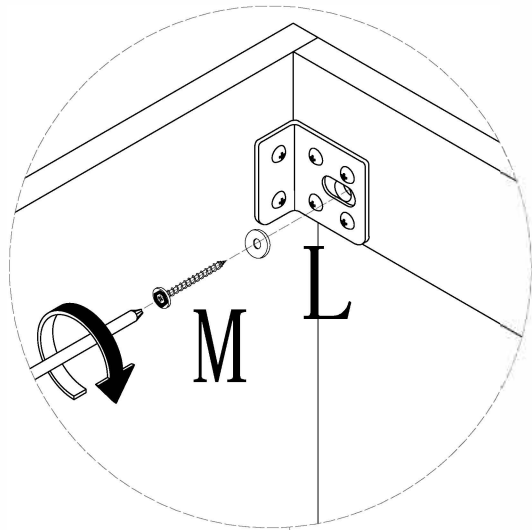

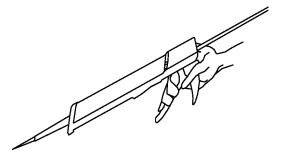

Step 10

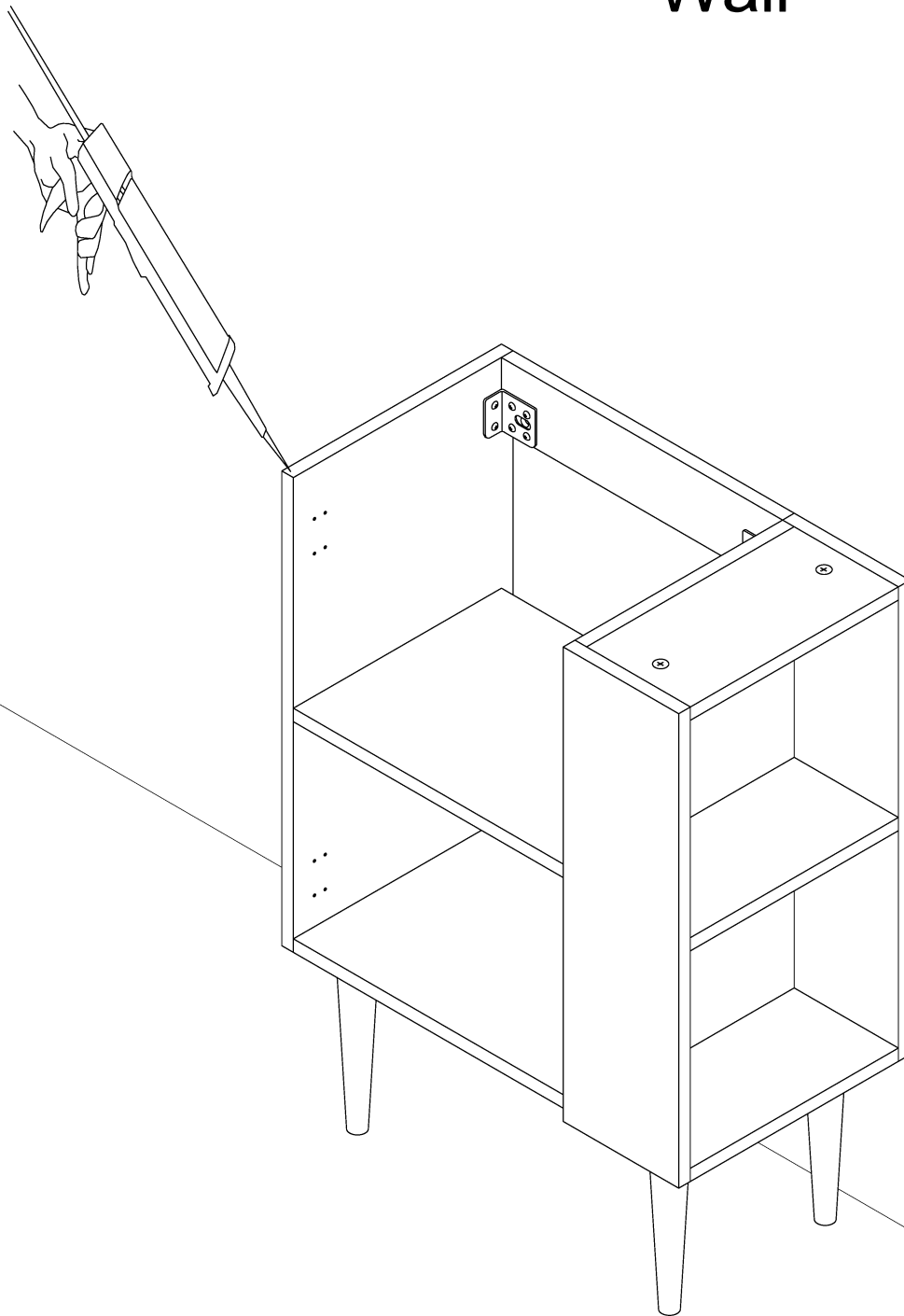

Wall



Step 11

E * 8	G * 1	H * 1
		
M4 x 14mm	M4 x 20mm	

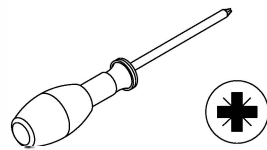

Wall

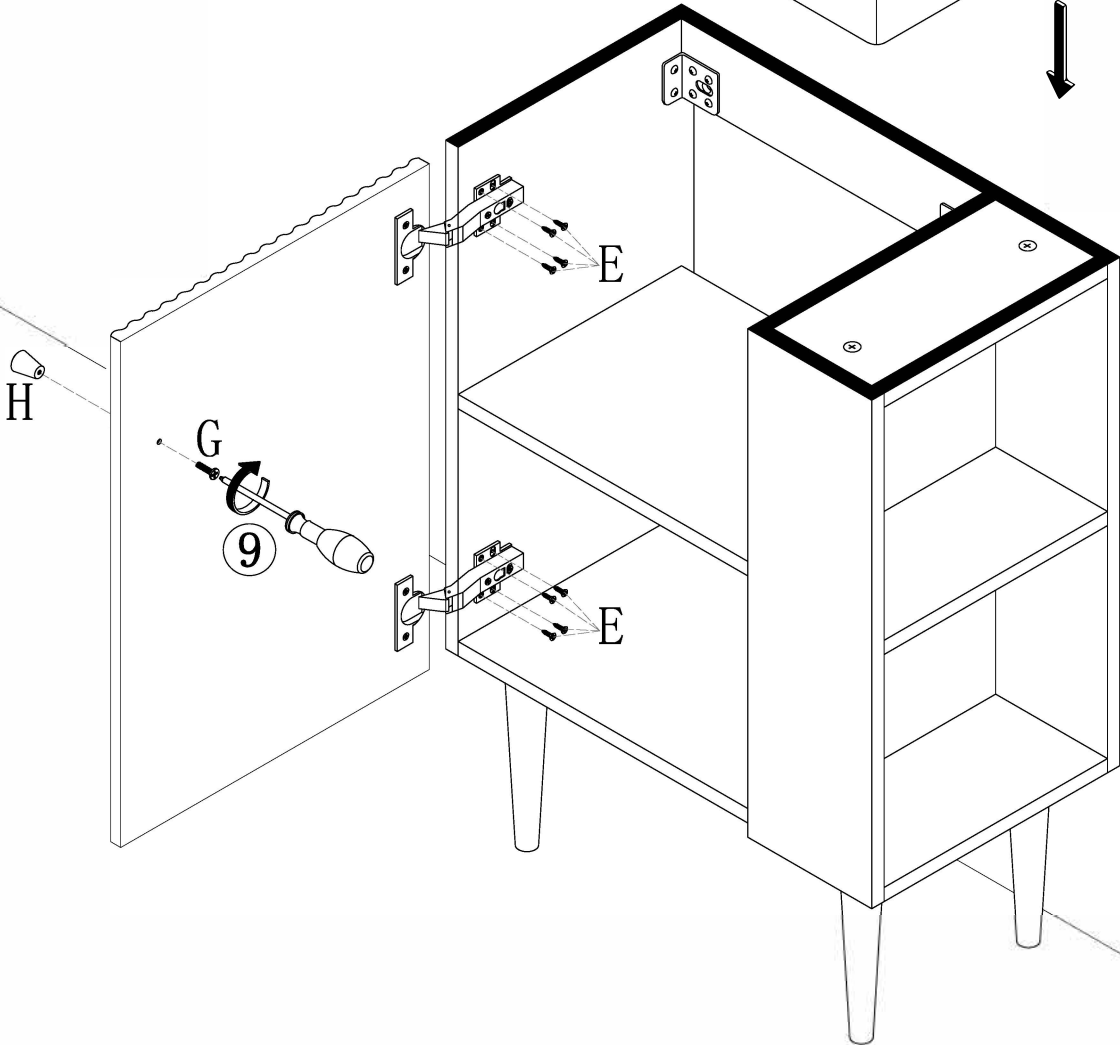
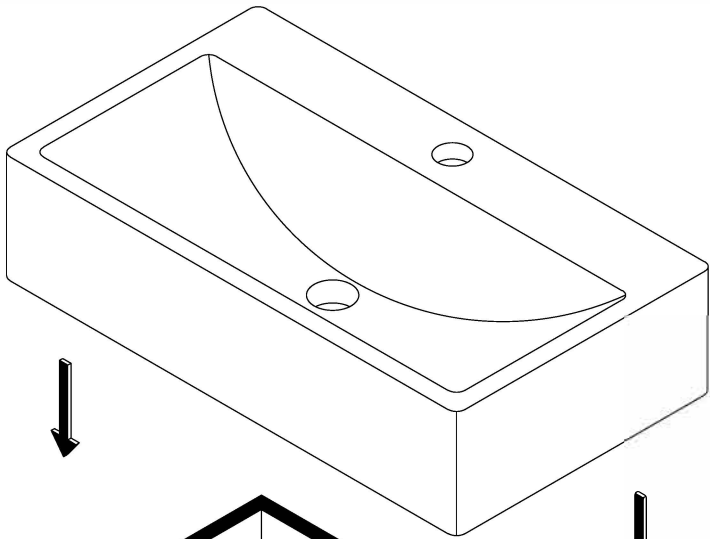

Step 12

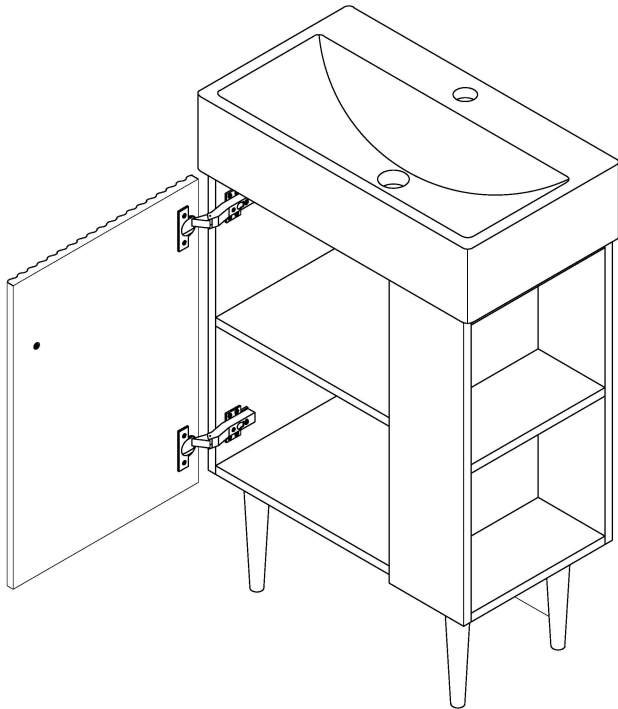
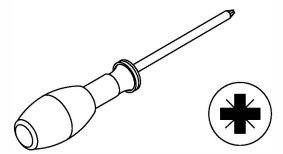

Adjust door following the direction.

Adjust the door up and down to match the cabinet.

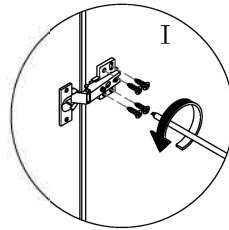

I:loosen the screw.

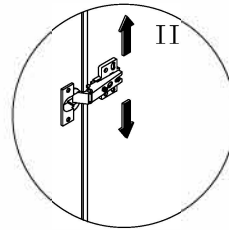

II:Adjust the upper and lower position.

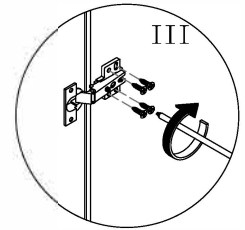

II:tighten the screw.



When the door position is not standard,please adjust the door according to the right picture.

Adjust the door left and right to match the cabinet for suitable crack of the door

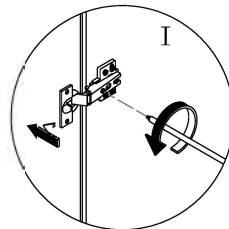

I:loosen the screw to keep hinge apply force toward the direction of arrow.

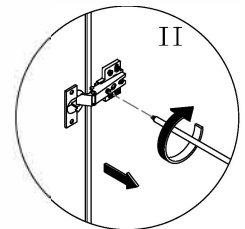

II:tighten the screw to keep hinge apply force toward the direction of arrow.



Please place the cabinet on the flat floor before adjustment.

Adjust the door backwards and forwards to match the cabinet.

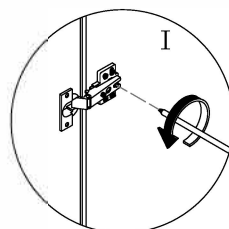

I:loosen the screw.

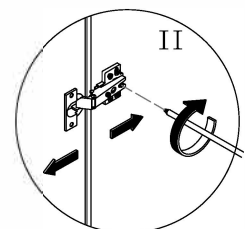

II:Adjust the distance between front and back.

Step 13

