

Assembly instructions

Product code: BW00367AAB

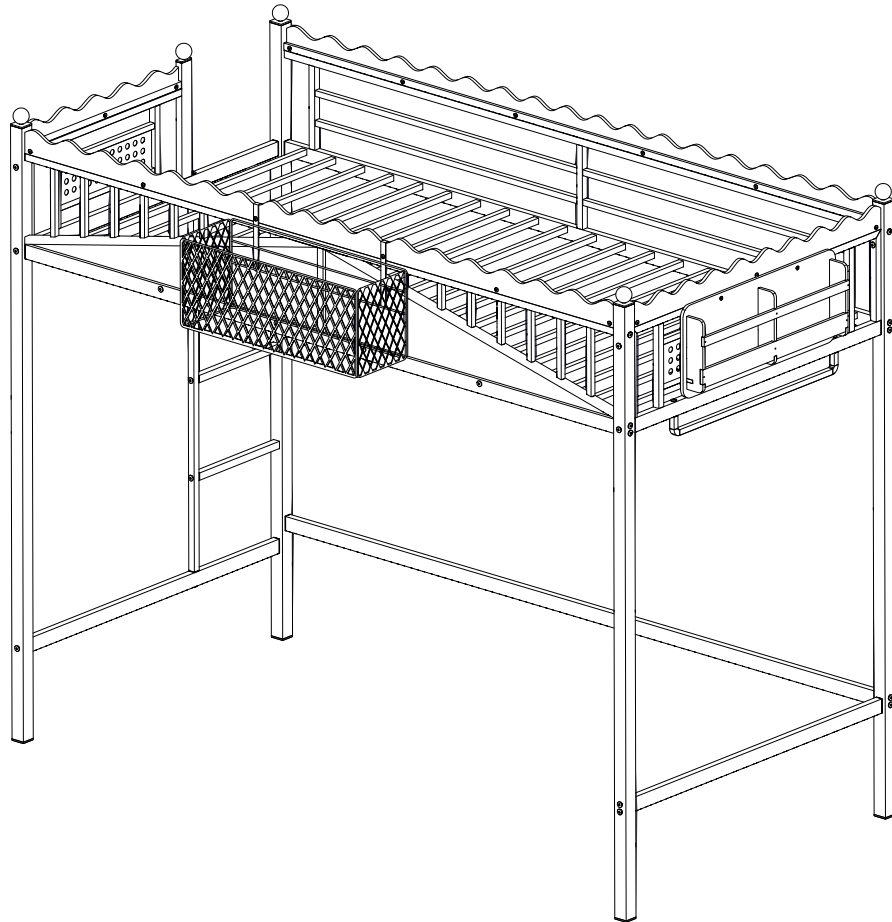

SAFETY WARNINGS AND GENERAL NOTES:

1. Follow the information on the warnings on the bunk bed end structure and on the carton. Do not remove the warning label from the bed.
2. Always use the recommended size mattress on mattress support, or both, to help prevent the likelihood of entrapment or falls.
3. Do not allow children under 6 years of age to use the upper bunk.
4. Periodically check and ensure the guardrail, ladder and other components are in their proper position, free from damage, and all connectors are tight.
5. Do not allow horseplay on or under beds.
6. Always prohibit jumping on the bed.
7. Prohibit more than one person on upper bunk.
8. Always use the ladder for entering and leaving the upper bunk.
9. Do not use substitute parts. Contact the manufacturer or dealer for replacement parts.
10. Use of a night-tight may provide added safety precaution for a child using the upper bunk.
11. Always use guardrails on both long sides of the upper bunk.
12. If the bunk bed will be placed next to a wall, the guardrail that runs the full length of the bed should be placed against the wall to prevent entrapment between the bed and the wall.

The use of water or sleep flotation mattresses is prohibited.

13. **STRANGULATION HAZARD**-Never attach or hang items to any part of the bunk bed that are not designed for use with the bed ; for example, but not limited to, hooks, belts and jump ropes.
14. Keep these instructions for future reference.
15. We recommend assembling your bunk bed on the shipping carton to protect your floor or carpet.
16. Be certain all staples are out of the box before beginning assembly on the shipping carton.
17. USE ONLY MATTRESSES WHICH ARE AS THE TABLE BELOW ON UPPER AND ON LOWER BUNKS.

Upper bed

Bed type	Length	Width	Thickness
Twin XL Standard	79" -80"	38 ½"	6" max

18. SURFACE OF MATTRESS MUST BE AT LEAST 5"(127MM) BELOW THE UPPER EDGE OF GUARDRAILS.

19. Replacement Parts:

Replacement Parts, including additional guardrails, may be obtained from any of our (Shenzhen Yuefeng Zhiqi Technology Co., Ltd) dealers.

Component distribution preview

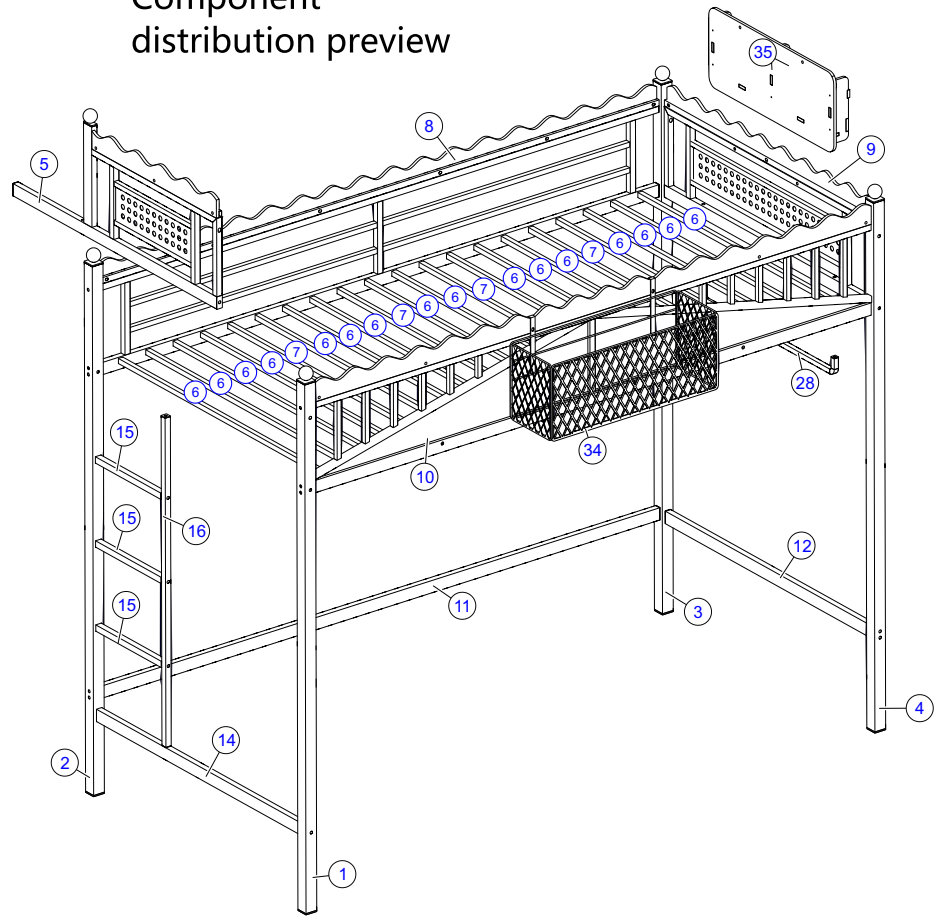

HARDWARE LIST

M8*55-33pcs	M8*30-11pcs	ΦM8*16-3 pcs	M8*15-3 pcs	M6*15-18pcs	M6*25-2 pcs	ΦM6*10-20pcs
40*40FQ-4pcs	M2.6*18-15pcs				M5*25-2pcs	
		20*40-1pcs	O-16pcs	40*40M8-5 pcs	M4*25-2pcs	2pcs
40*40F-4pcs	Z-1pcs					

List of components

1-1pcs	2-1pcs	3-1pcs	4-1pcs	8-1pcs	6-16pcs
				10-1pcs	7-4pcs
5-1pcs				11-1pcs	12-1pcs
9-1pcs				14-1pcs	15-3pcs
				16-1pcs	28-1pcs
34-1pcs				35-1pcs	

No. 34 Component List

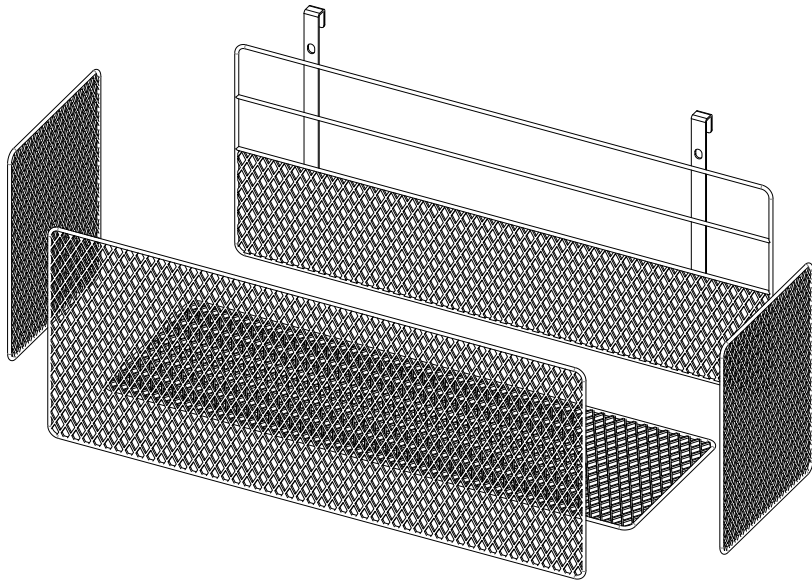

Use a customized tie to bundle all the parts of the No. 34 component together, and use the tool to cut off the tail length of the tie.

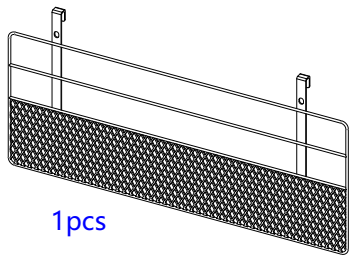
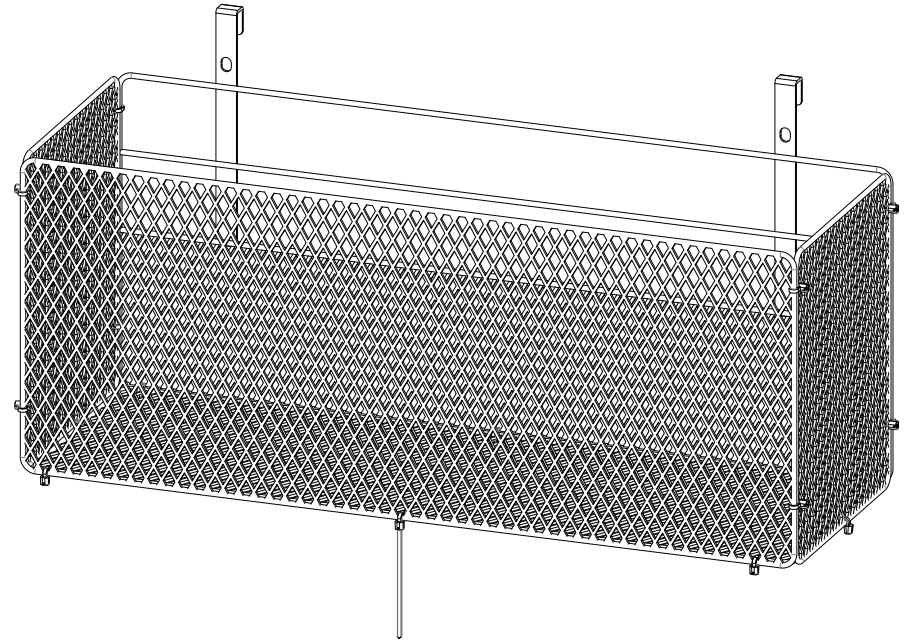

1pcs

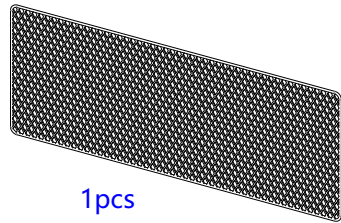

1pcs

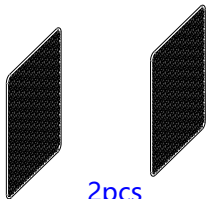

2pcs

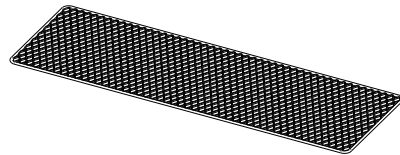

1pcs

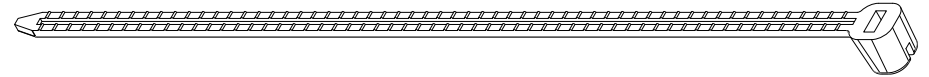

O-16pcs

No. 35 Component List

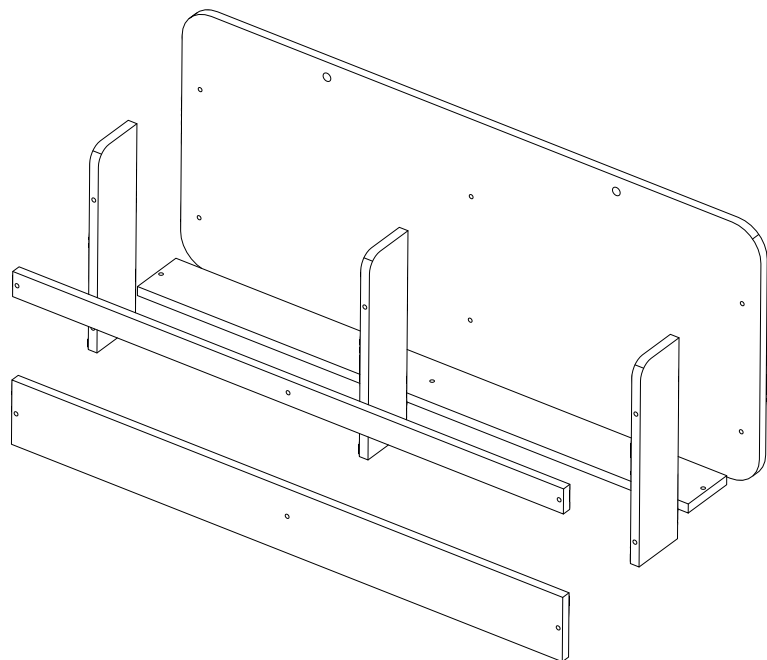

Use screw Z, S accessories to combine the parts required for the No. 35 component.

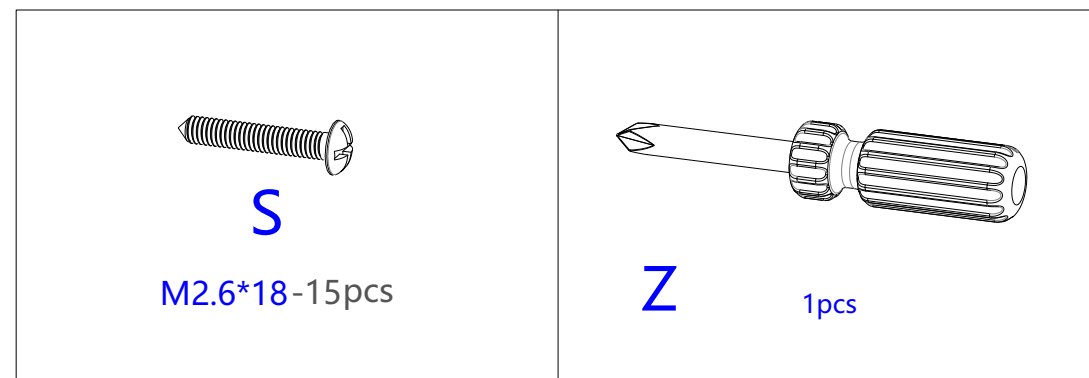
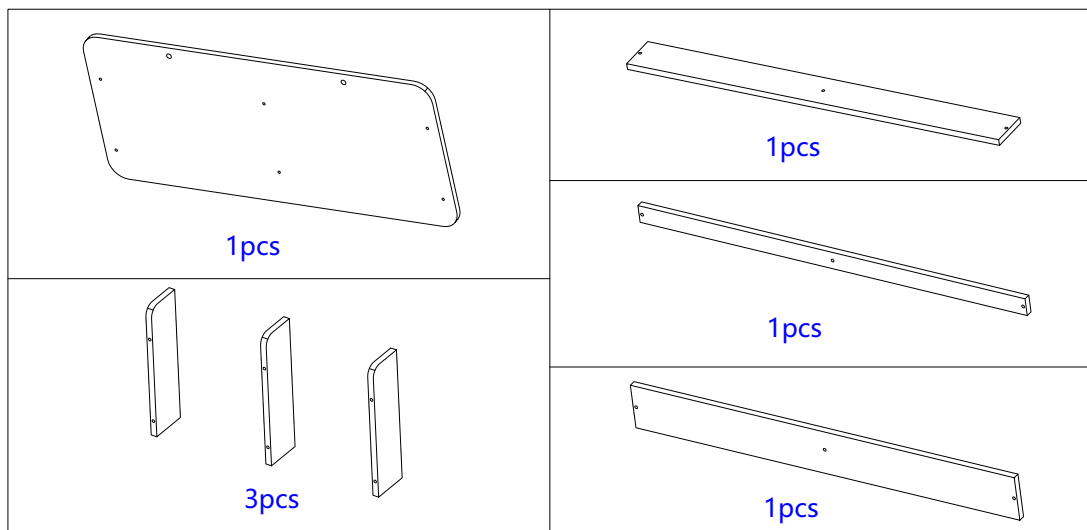
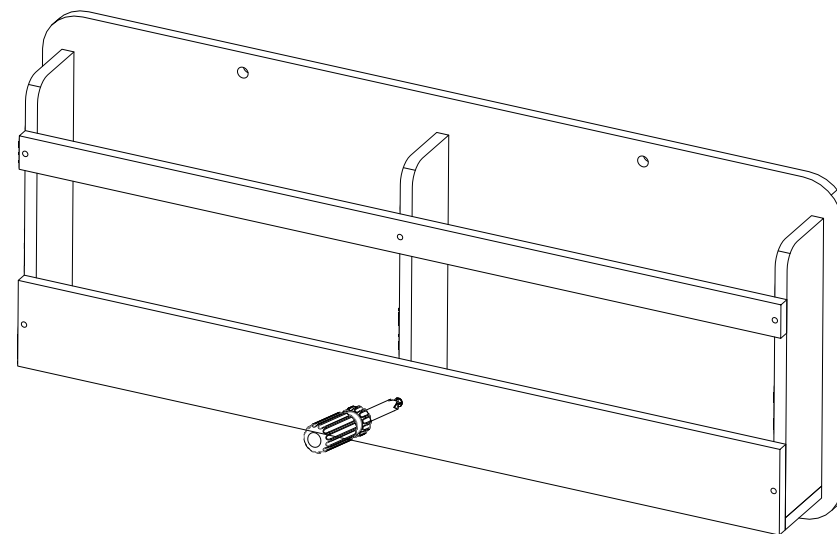



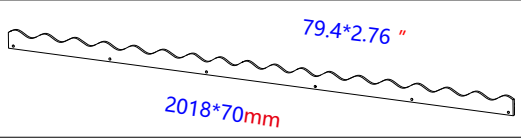
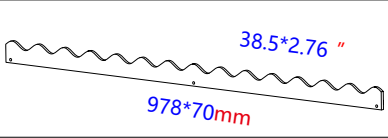
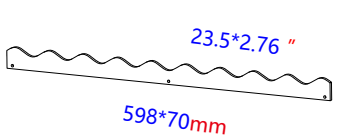

Board list

	
36-2pcs	37-1pcs
	
38-1pcs	

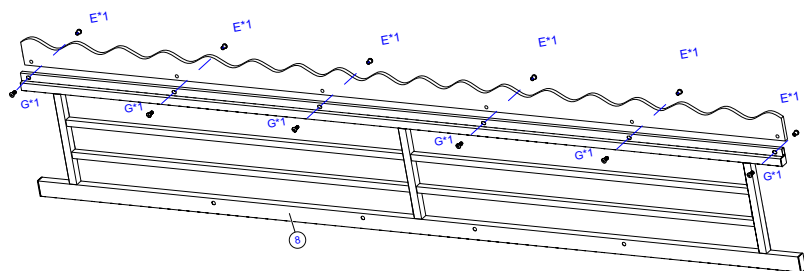
A total of 4 pcs

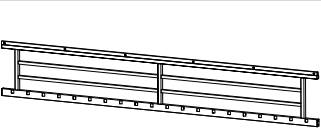
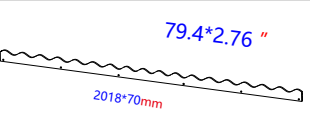

Step 1: Use hardware E, G, L to connect #8 and #36 together. Get 8 # components

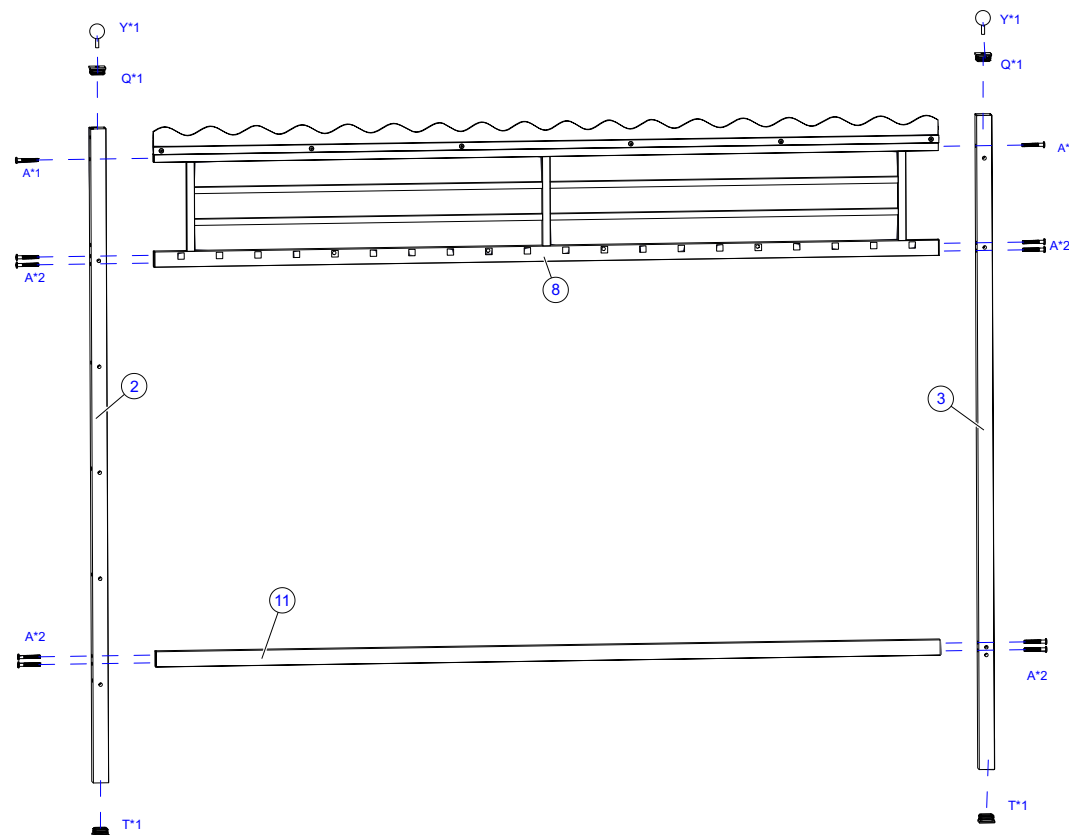

				
8-1pcs	36-1pcs	M6*15-6pcs	ΦM6*10-6pcs	L

Step 2: Use hardware A, T, Q, Y to connect #2 #3 #11 and #8 components together.

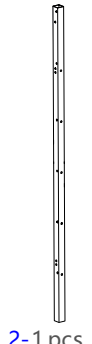
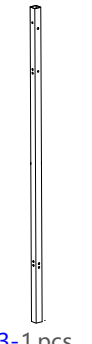

			
2-1 pcs	3-1 pcs	11-1pcs	1 pcs 8 # components
			40*40F-2pcs
			40*40FQ-2pcs
			20*40-2pcs
			M8*55-10pcs

Step 3: Use hardware E, G, L to connect #10 #34 and #36 together.

Get #10 components

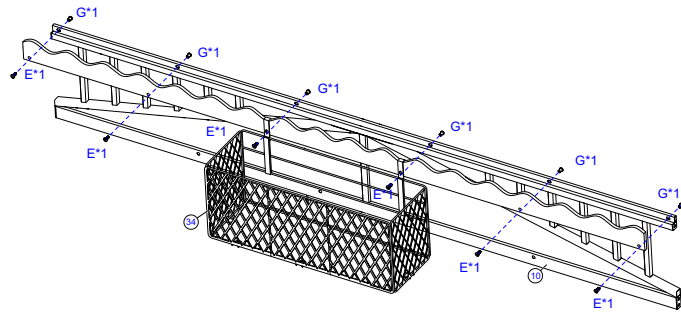

 10-1pcs	 79.4*2.76" 2018*70mm 36-1pcs	 34-1pcs	 E M6*15-6pcs	 G ΦM6*10-6pcs
-------------	--	-------------	---------------------	----------------------

Step 4: Use hardware A, L, T, Q, Y to connect #1 #4 and #10 components together.

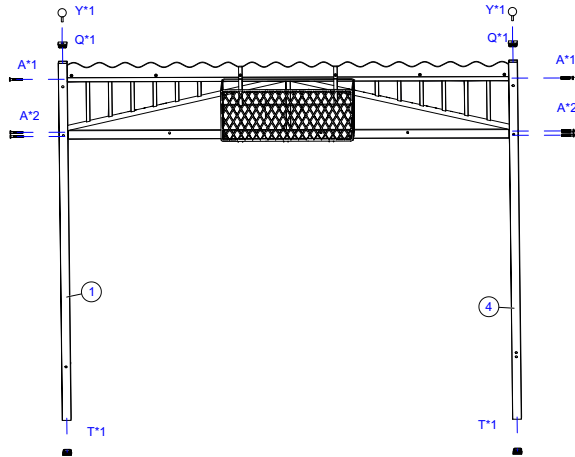

 1-1 pcs	 1 pcs #10 components	 Q 40*40FQ-2pcs	 A M8*55-6pcs
 4-1 pcs	 T 40*40F-2pcs	 Y 20*40-2pcs	 L

Step 5: Use hardware E, G, W, M, Y to connect #5 #38 together.

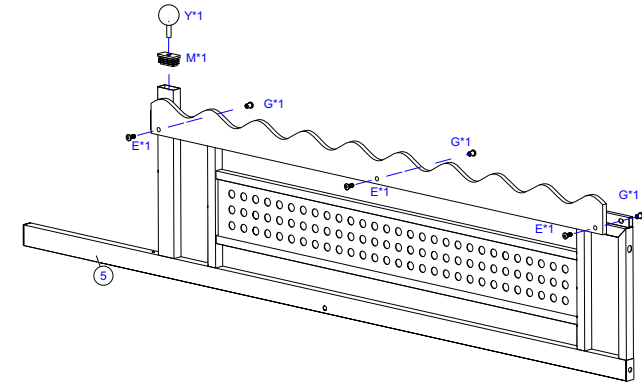

 5-1pcs	 23.5*2.76" 598*70mm 38-1 pcs	 M 20*40-1 pcs	 Y 40*40-1pcs	 E M6*15-3pcs	 G ΦM6*10-3pcs
------------	--	----------------------	---------------------	---------------------	----------------------

Step 6: Use hardware E, G, W to connect #9 #37 together.

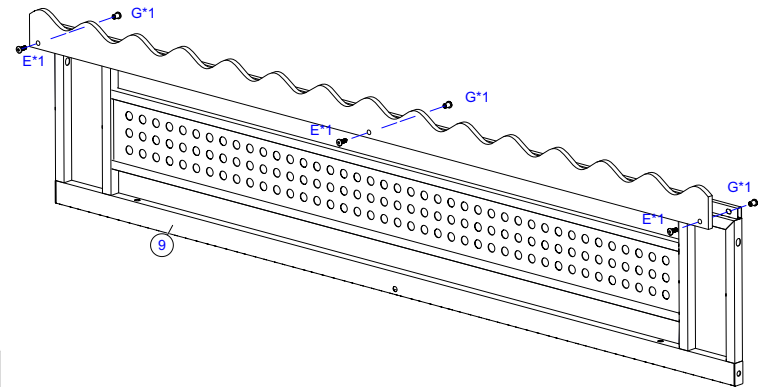

 9-1pcs	 38.5*2.76" 978*70mm 37-1pcs	 E M6*15-3pcs	 G ΦM6*10-3pcs
------------	---------------------------------------	---------------------	----------------------

Step 7: Use hardware A, L to connect #12 #14 together.

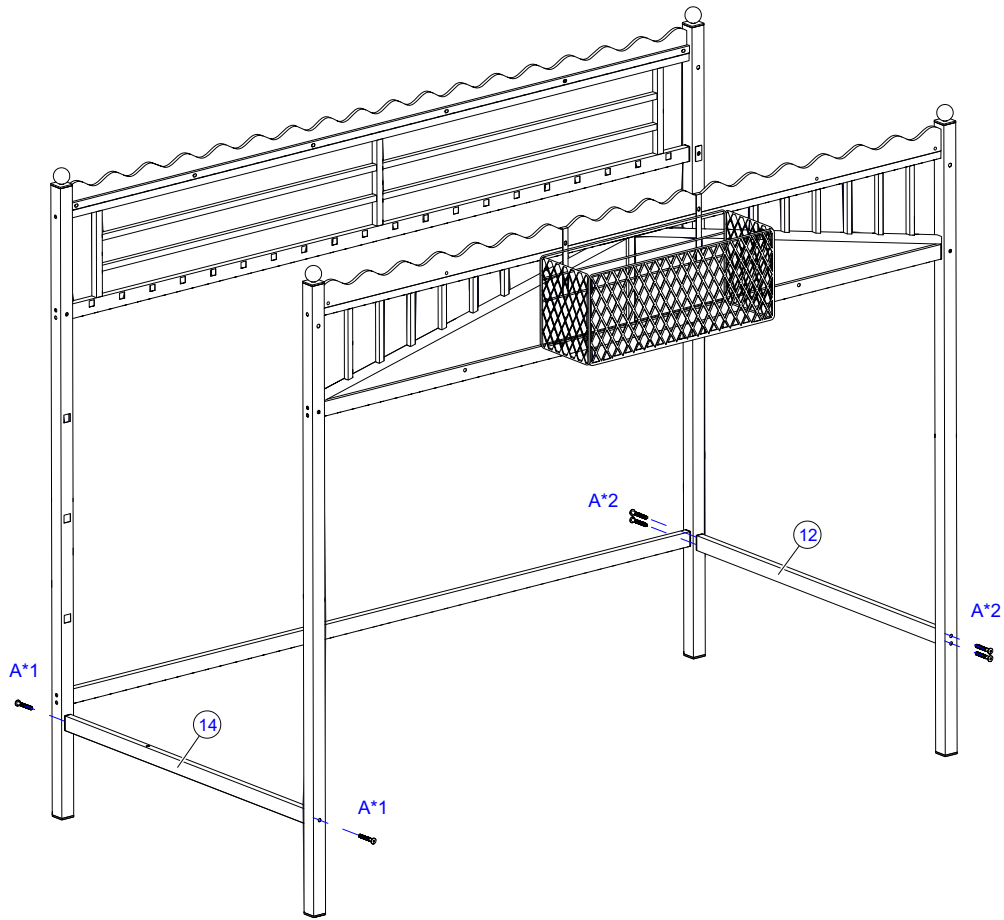

<p>12-1pcs</p>	<p>14-1pcs</p>	<p>A M8*55-6pcs</p>	<p>L</p>
----------------	----------------	-------------------------	----------

Step 8: Use #6 and #7 to insert into the corresponding square hole of #8 #10 and use hardware C, L to connect #7, #8, #10 together.

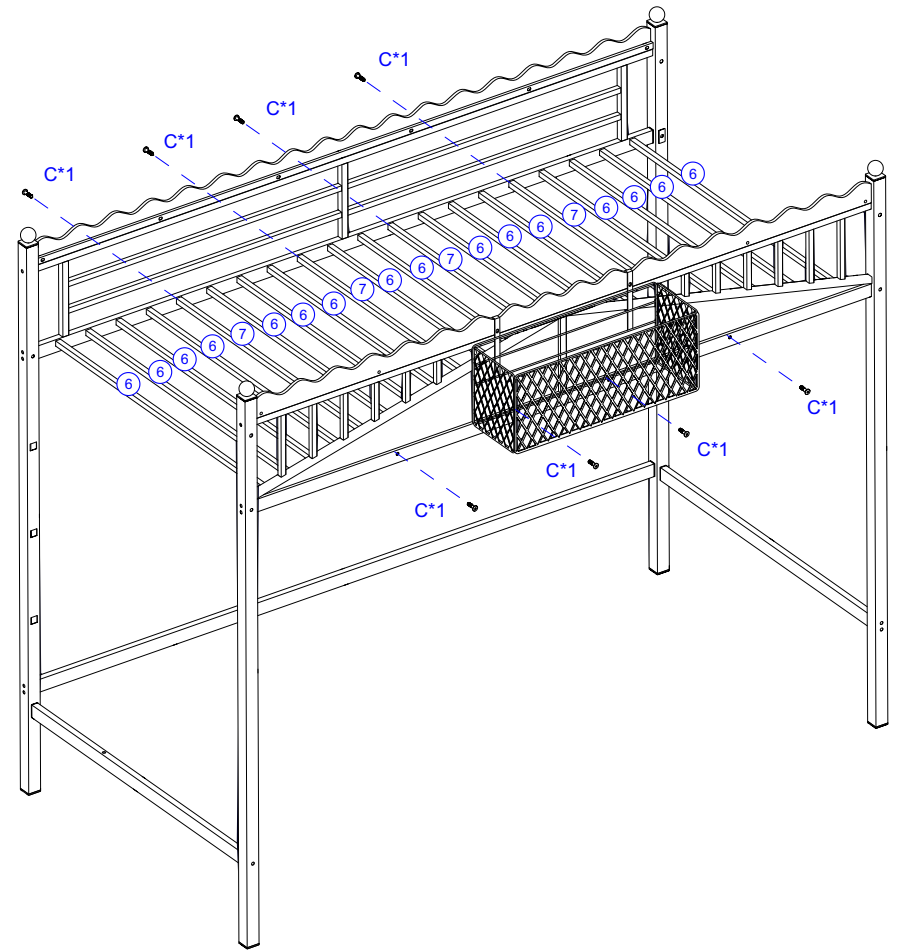

<p>6-16pcs</p>	<p>7-4pcs</p>	<p>C M8*30-8 pcs</p>	<p>L</p>
----------------	---------------	--------------------------	----------

Step 9: Use hardware A, D L to connect #5, #9 together.

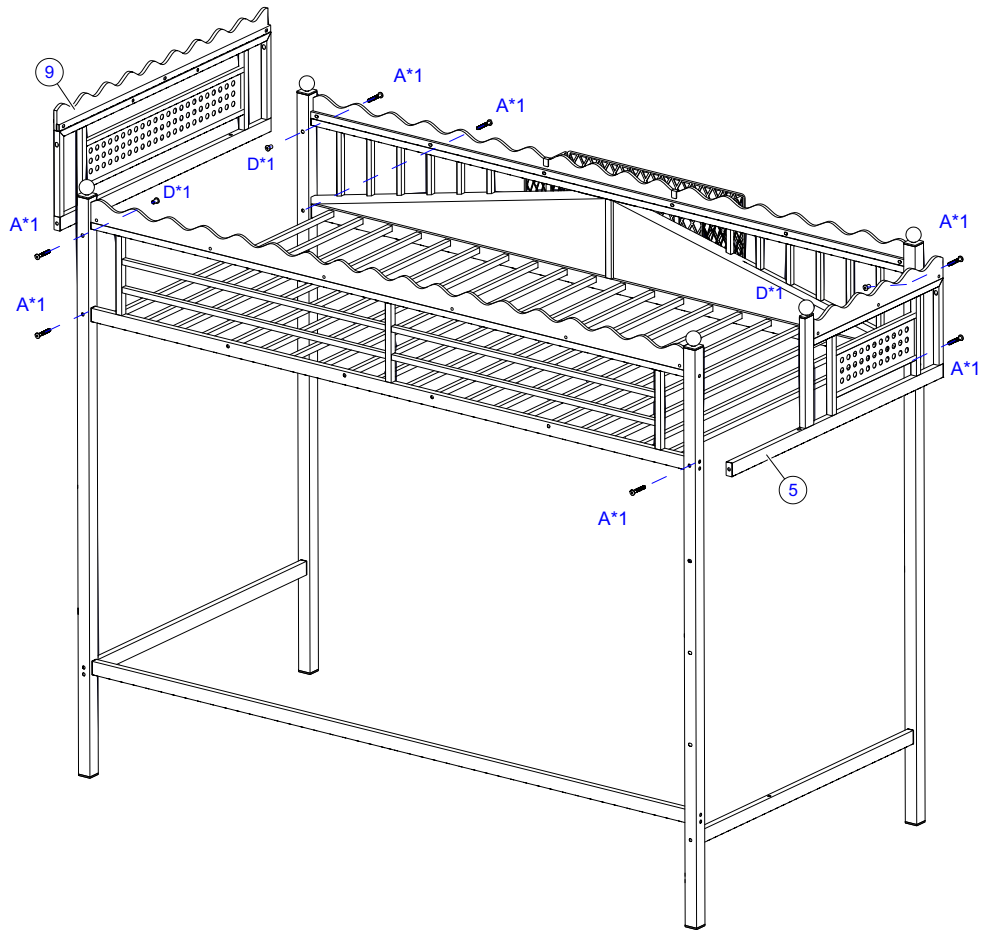

5-1pcs	9-1pcs	M8*55-7pcs	ΦM8*16-3pcs



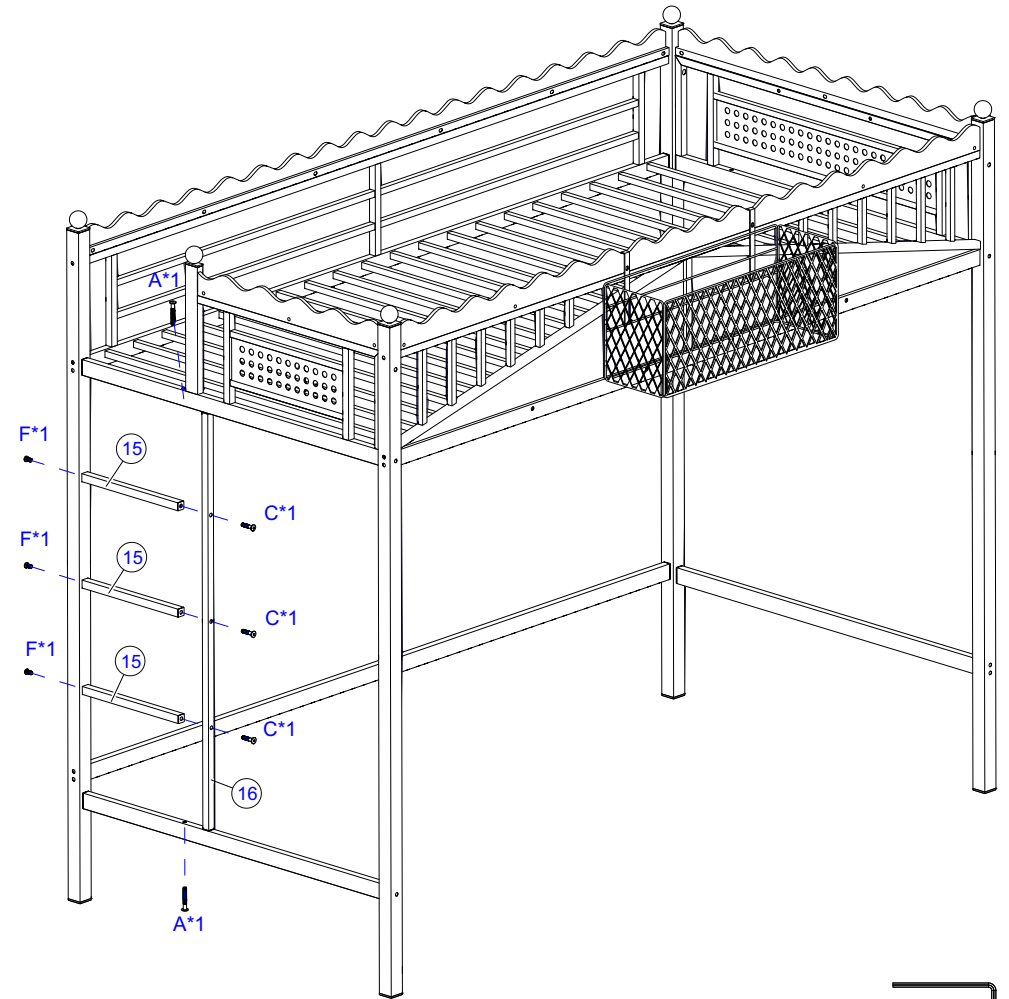

Step 10: Use hardware A, C, F to connect #15, #16 together.

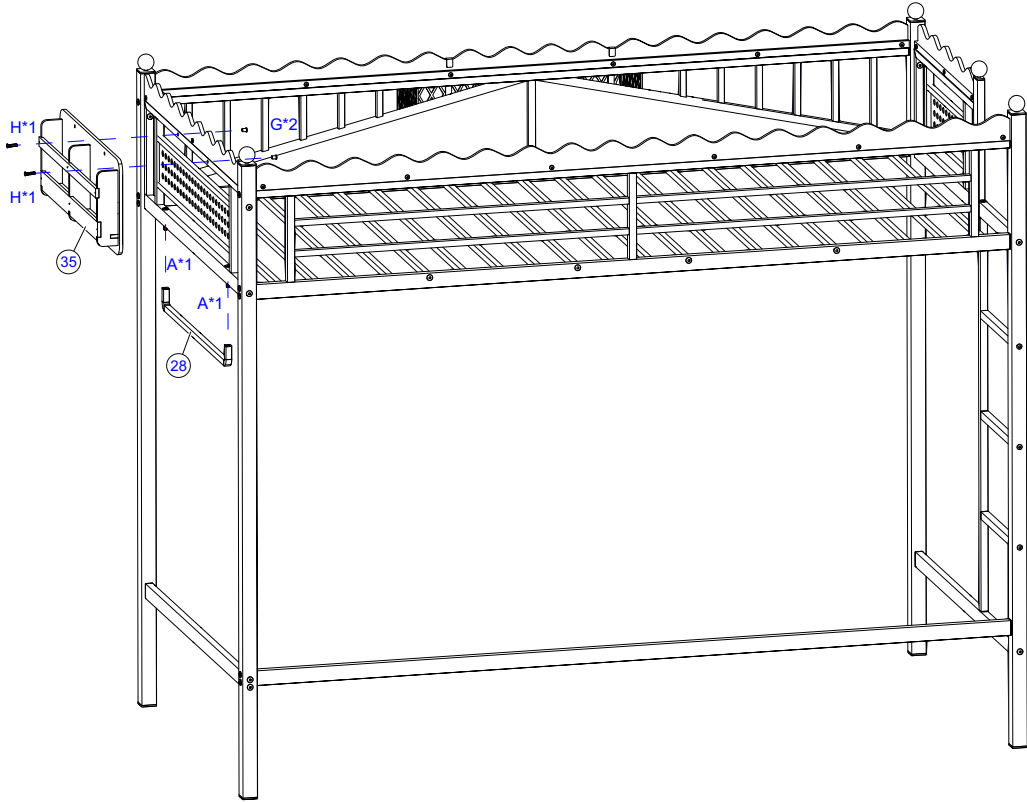

15-3pcs	16-1pcs	M8*55-2pcs	M8*30-3pcs	M8*15-3pcs

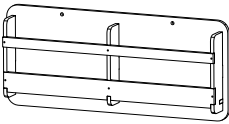
Step 11: Use hardware A,H,G to connect #28,#35 together.



 <p>35-1pcs</p>	 <p>28-1pcs</p>	 <p>A M8*55-2pcs</p>	 <p>G ΦM6*10-2pcs</p>	 <p>H M6*25-2pcs</p>
--	--	---	--	---

Completed attic bed

Fix the wall, prevent movement, selective installation

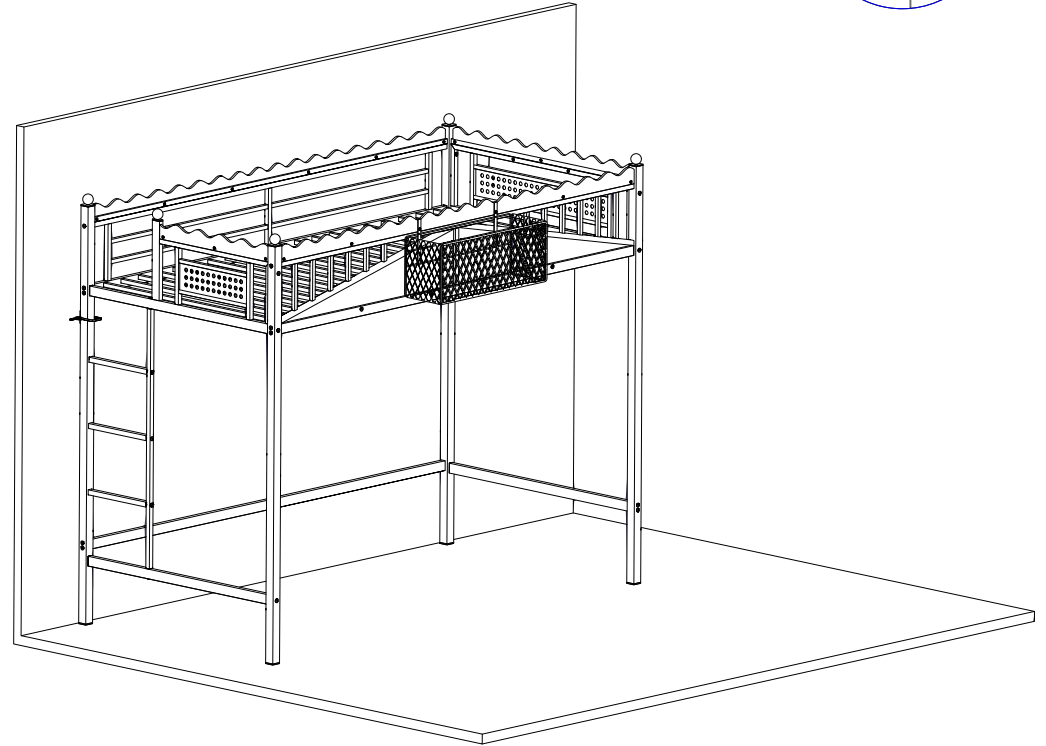
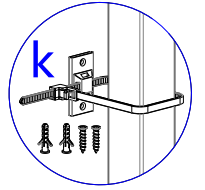

Note: Tighten all the steps before use, thank you.



Recyclable garbage