

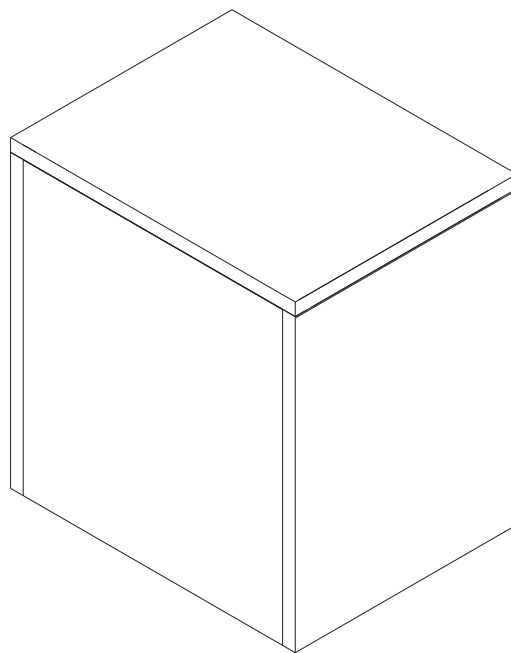

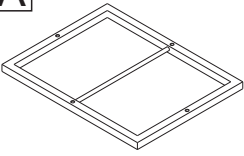

Outdoor Wicker Rectangular Side Table

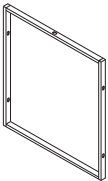

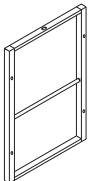

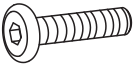
PART LIST

A 	B 	C 
Wicker Top 1PC	Side Panel 2PCS	End Panel 2PCS

HARDWARE LIST

#1 	#2 	#3 	#4 
M6*30mm Bolt 12PCS	M6mm Washer 12PCS	M6mm Allen Key 1PC	M6mm Adjustable Leveler 4PCS

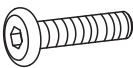

EXTRA HARDWARE LIST

#1 	#2 	#4 
M6*30mm Bolt 3PCS	M6mm Washer 3PCS	M6mm Adjustable Leveler 1PC

Step 1. Lay wicker top (part #A) on a flat surface with underside facing up. Attach one side panel (part #B) to the wicker top (part #A) using bolts (part #1), washers (part #2) and allen key (part #3). Attach one end panel (part #C) to the assembled parts (part #A & B) using bolts (part #1), washers (part #2) and allen key (part #3).

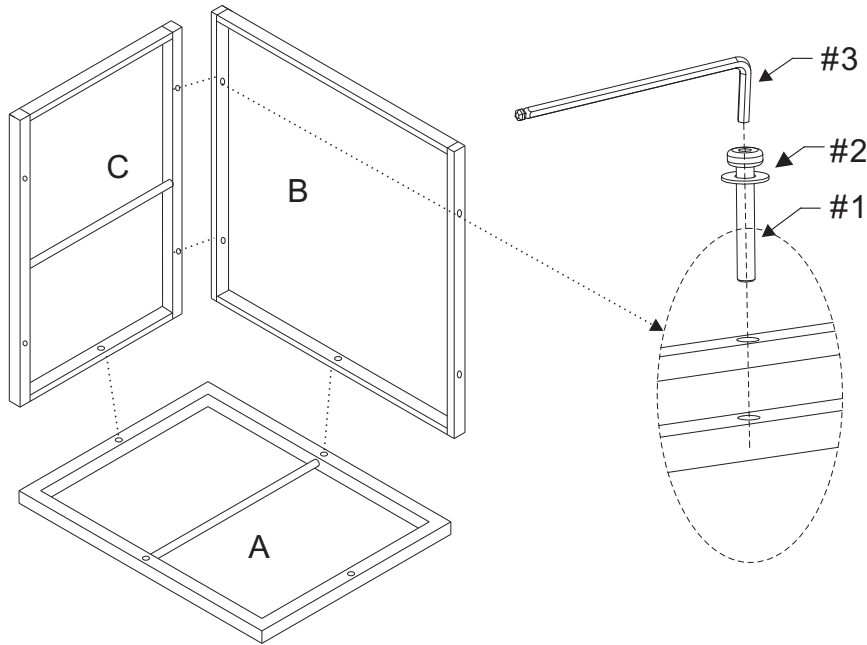
NOTE: Please do not fully tighten bolts until unit is fully assembled.





- | | | |
|----|---|----|
| #1 |  | x4 |
| #2 |  | x4 |
| #3 |  | x1 |

Step 2. Attach remaining side panel (part #B) to the assembled parts (part #A, B & C) using bolts (part #1), washers (part #2) and allen key (part #3). Attach remaining end panel (part #C) to the assembled parts (part #A, Bx2 & C) using bolts (part #1), washers (part #2) and allen key (part #3).

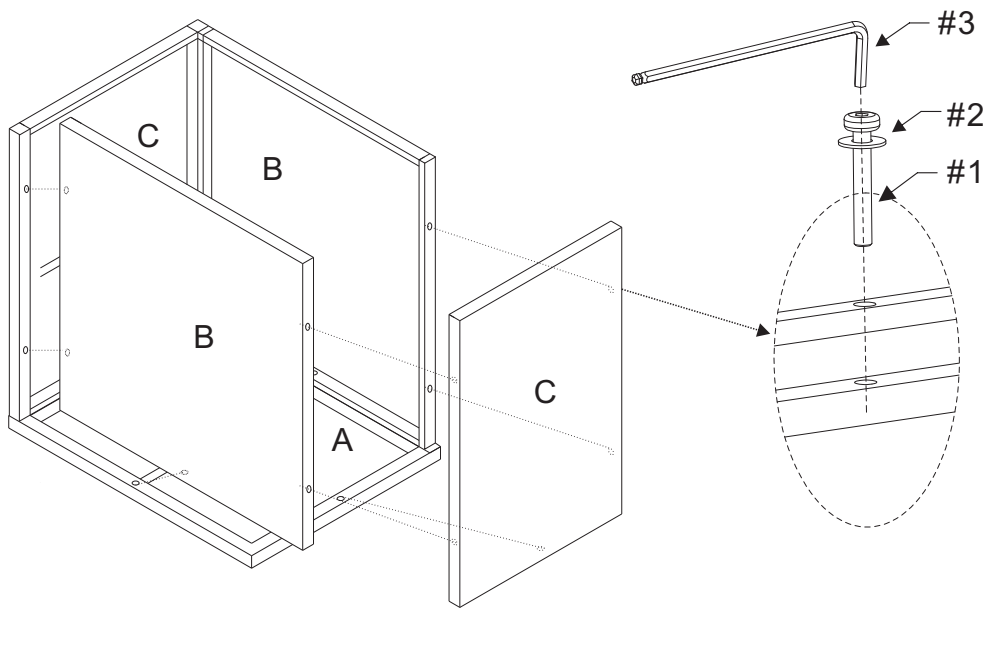
NOTE: Please fully tighten all bolts at this time.



- | | | |
|----|---|----|
| #1 |  | x8 |
| #2 |  | x8 |
| #3 |  | x1 |

Step 3. Screw the adjustable levelers (part #4) into the bottom of the table. Adjust as needed to desired position.

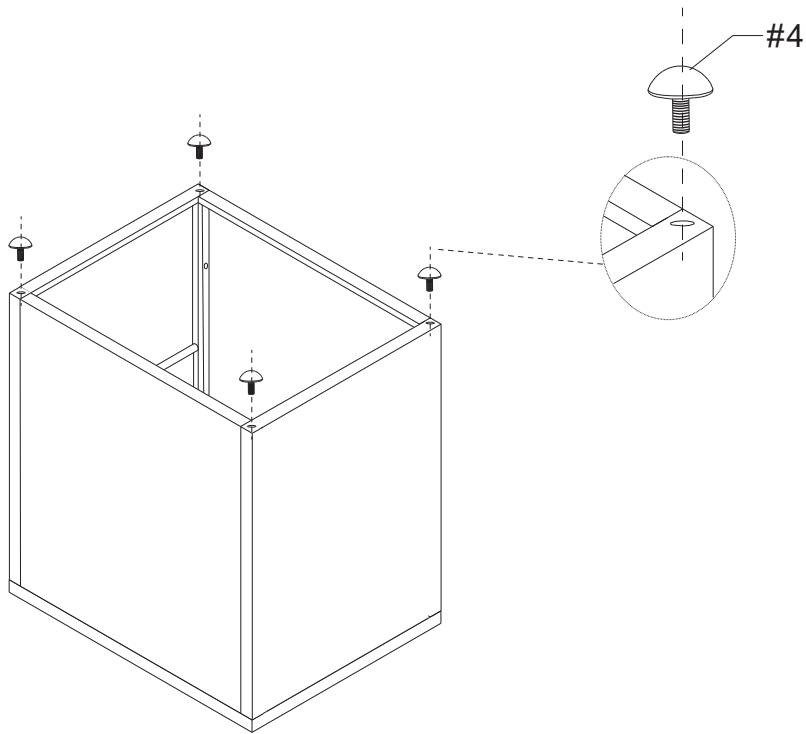

#4  x4

Step 4. Carefully turn the table upright.

