

Assembly Instructions

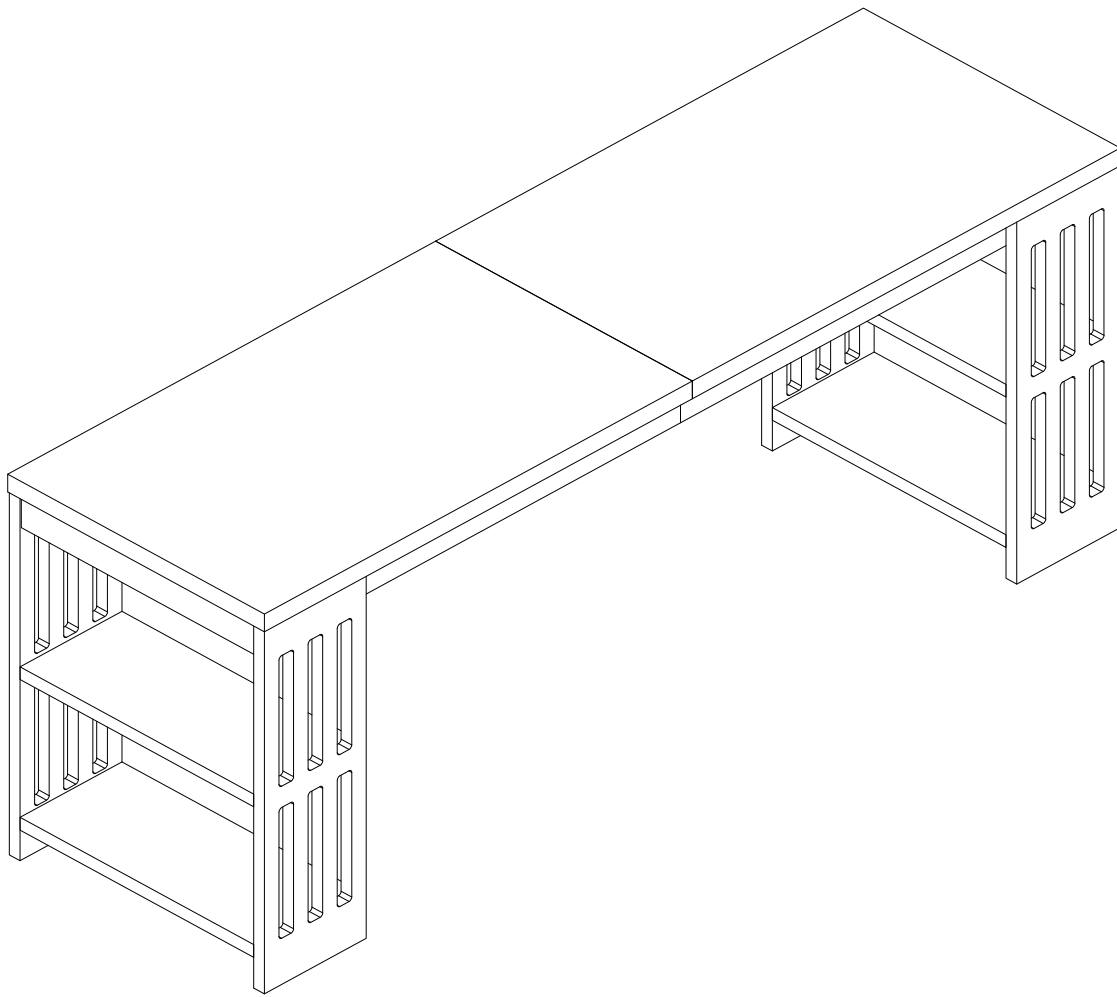

Long Table

Contact Us

We're here to help you.

Your satisfaction is our top priority. If you encounter any issues with this product, such as missing or damaged parts, we're here to help. Please retain the original packaging and take photos of the packaging and the product, then contact us as soon as possible.

Warm Tips

1. Carefully read these instructions and keep them for future reference.
2. Check the parts list and confirm everything's there before starting assembly.
3. When assembling, put all parts on a soft, smooth surface like a carpet to avoid scratches.
4. Don't fully tighten screws until all parts are confirmed in place to avoid misalignment.

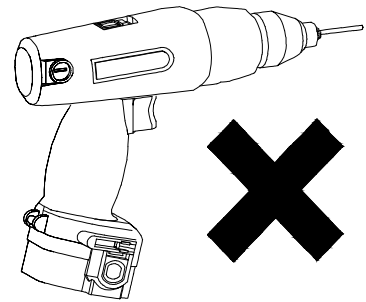
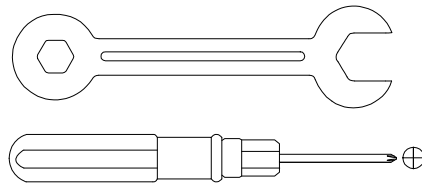
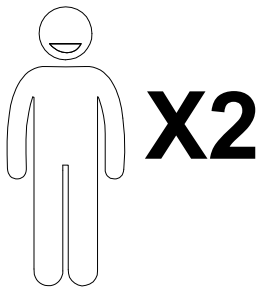

We recommend using hand tools for assembly.

If an electric screwdriver is used, reduce power and torque to avoid damage to the product.

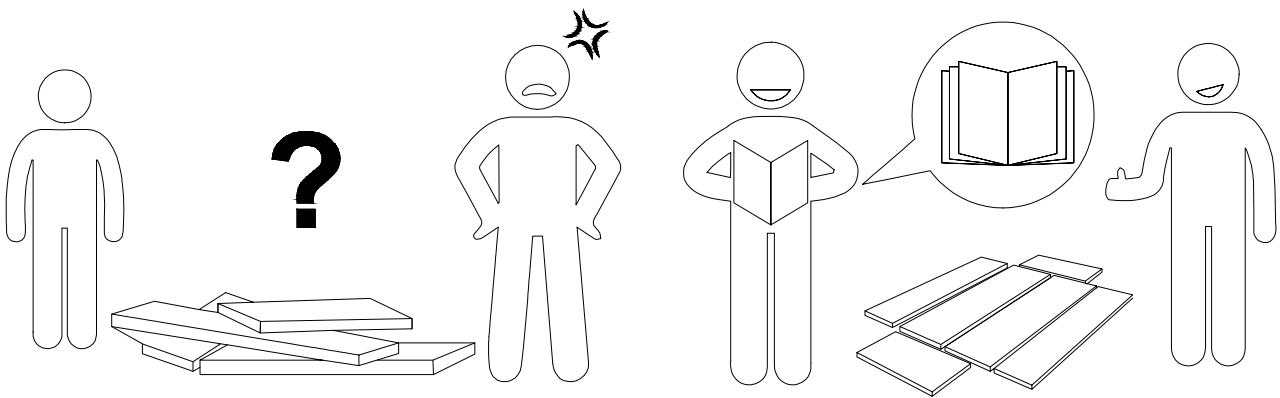

AVOID SCRATCHES

In order to avoid scratching, this furniture should be assembled on a soft surface, such as a rug.

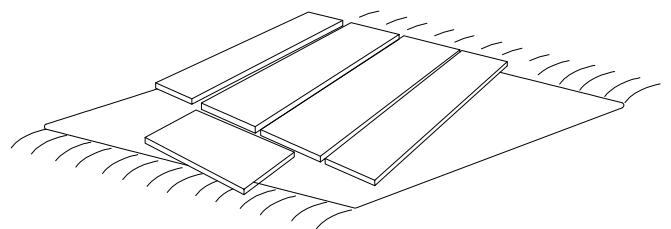
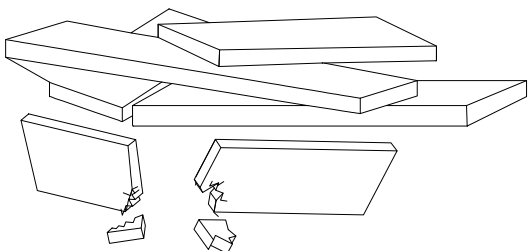

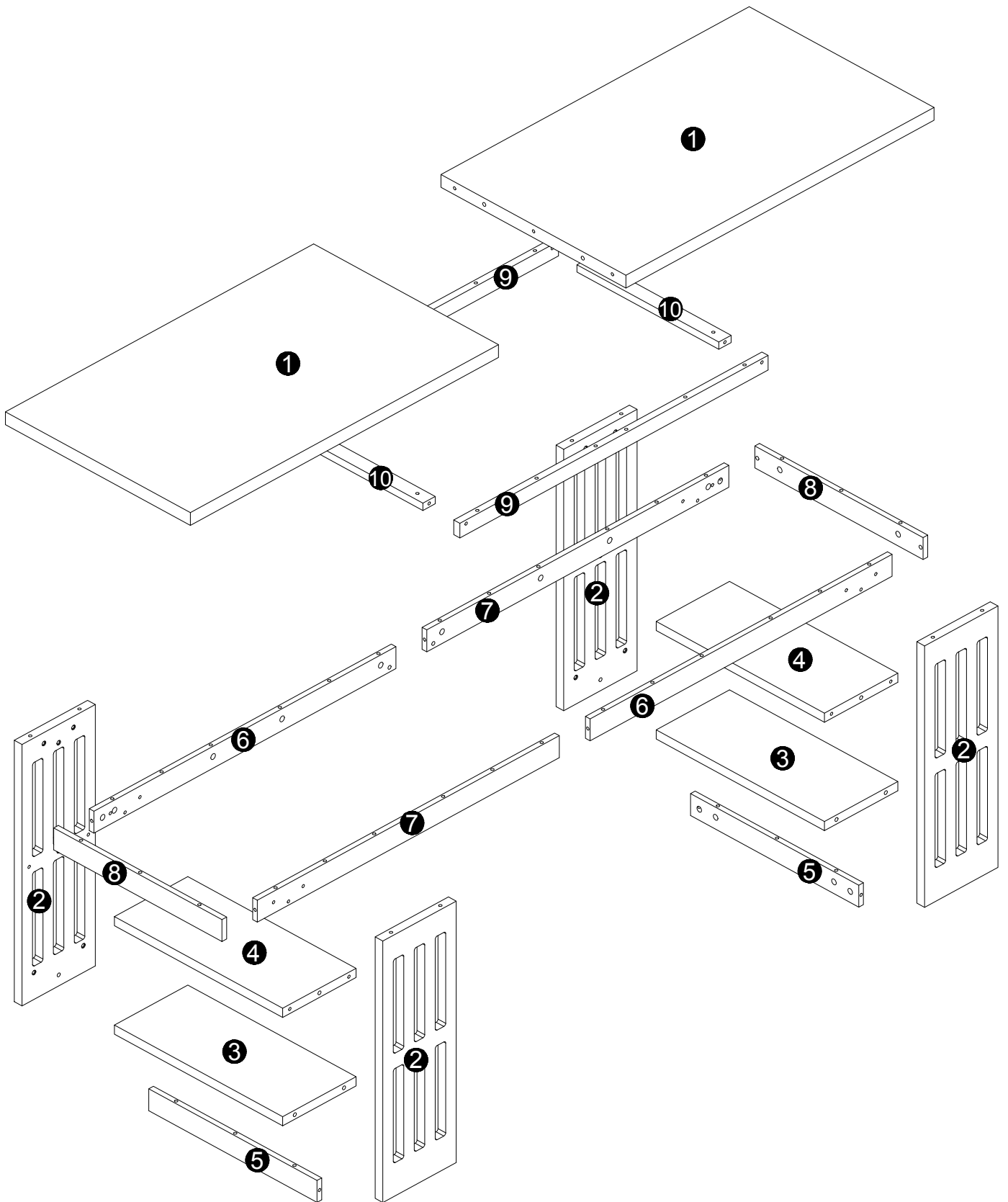





⚠ Caution

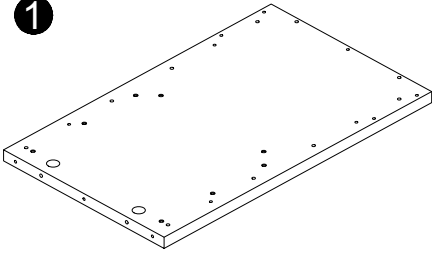
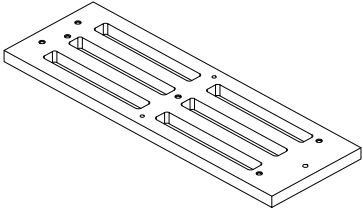
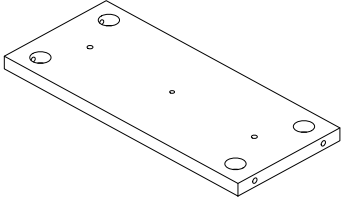
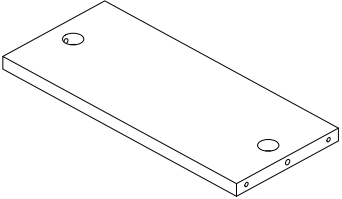
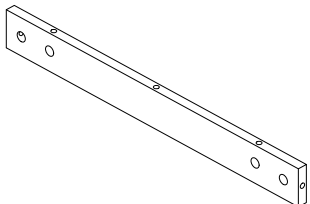
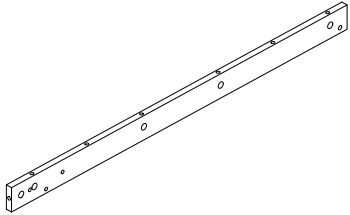
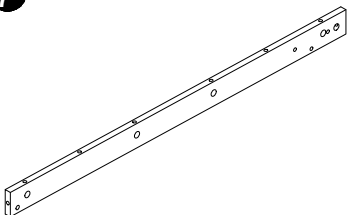
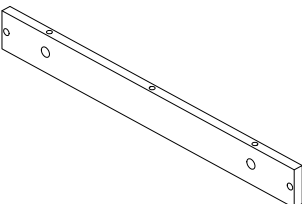
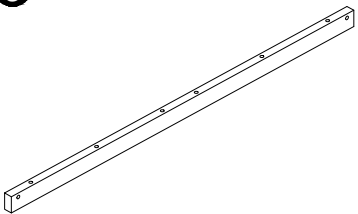
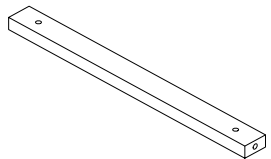

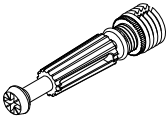

Make sure all parts are included. Most board parts are labeled or stamped on the raw edge. Contact us for a free replacement if you encounter any damaged or missing parts.

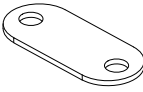

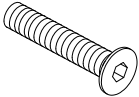

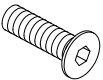
Parts List

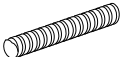
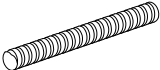
| | | |
|---|---|---|
| <p>1</p>  <p>2 pcs</p> | <p>2</p>  <p>4 pcs</p> | <p>3</p>  <p>2 pcs</p> |
| <p>4</p>  <p>2 pcs</p> | <p>5</p>  <p>2 pcs</p> | <p>6</p>  <p>2 pcs</p> |
| <p>7</p>  <p>2 pcs</p> | <p>8</p>  <p>2 pcs</p> | <p>9</p>  <p>2 pcs</p> |
| <p>10</p>  <p>2 pcs</p> | | |

Hardware List

| A | B | C | D | E | F |
|---|---|---|---|---|---|
|  |  |  |  |  |  |
| Ø6x40mm | Ø15x12mm | | Ø8x30mm | Ø6x35mm | Ø6x55mm |
| 32+1 pcs | 32+1 pcs | 2 pcs | 25+1 pcs | 8+1 pcs | 12+1 pcs |

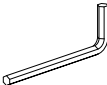
| G | H | I | J | K | L |
|---|---|---|---|---|---|
|  |  |  |  |  |  |
| Ø6x30mm | Ø6x10mm | Ø10x40mm | Ø8x60mm | Ø8x90mm | M8 |
| 12+1 pcs | 4+1 pcs | 8+1 pcs | 12+1 pcs | 2+1 pcs | 16 pcs |

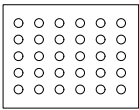
| M | N | O | P | Q | R |
|---|---|---|---|---|---|
|  |  |  |  |  |  |
| M8 | Ø25x2mm | | M3 | M14 | Ø20 |
| 16 pcs | 10 pcs | 1 pc | 1 pc | 1 pc | 32 pcs |

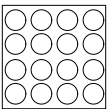
| S |
|---|
|  |
| Ø40 |
| 16 pcs |

Installation of Cams and Pins

Step 1-2: Align the plastic part with the mounting hole and press it in. If you can't press it in, loosen the screw counter clockwise or completely remove the screw from the plastic part and try again.
Step 3-4: After pressing the plastic part into place, use a screwdriver to tighten the screw clockwise.

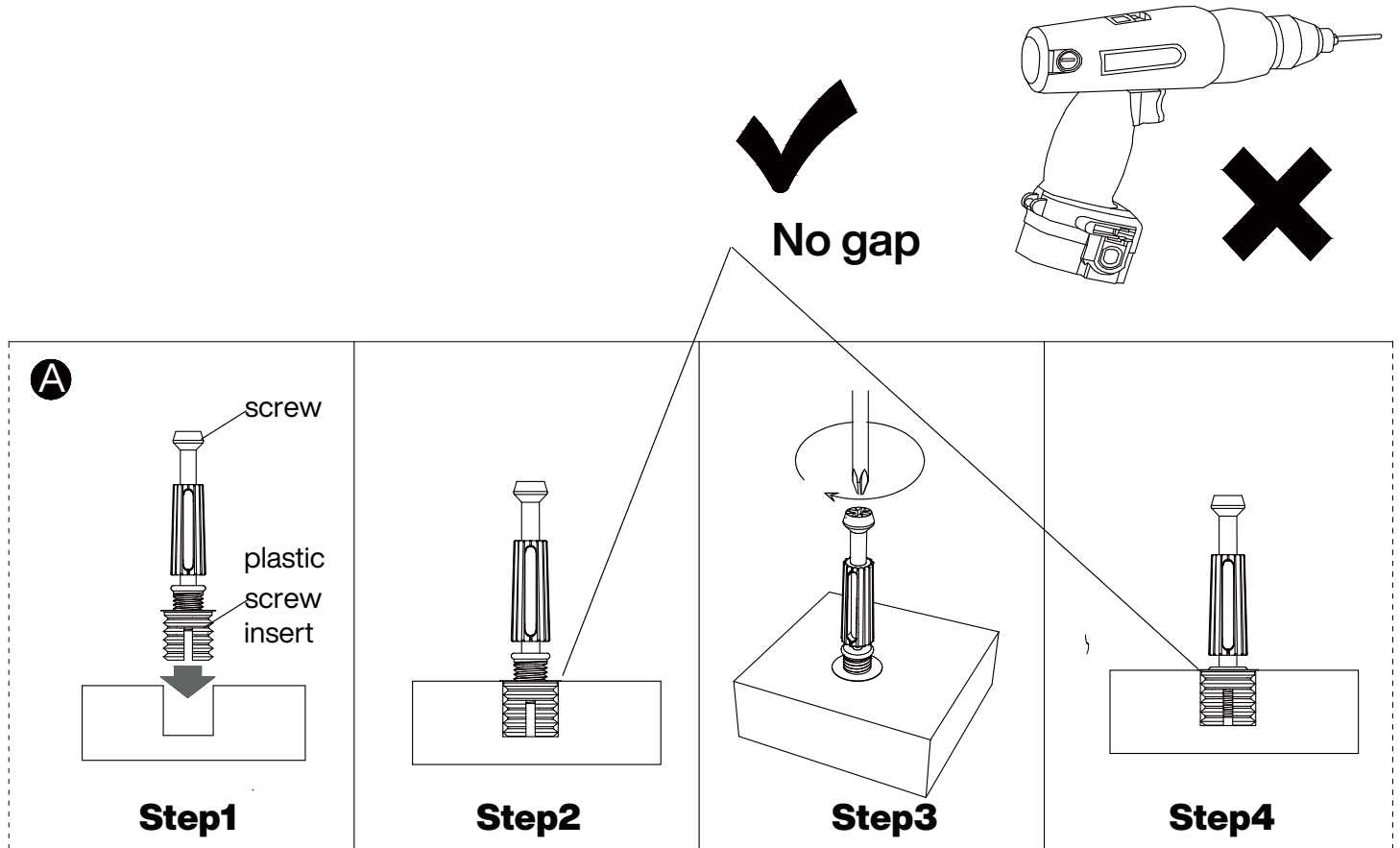

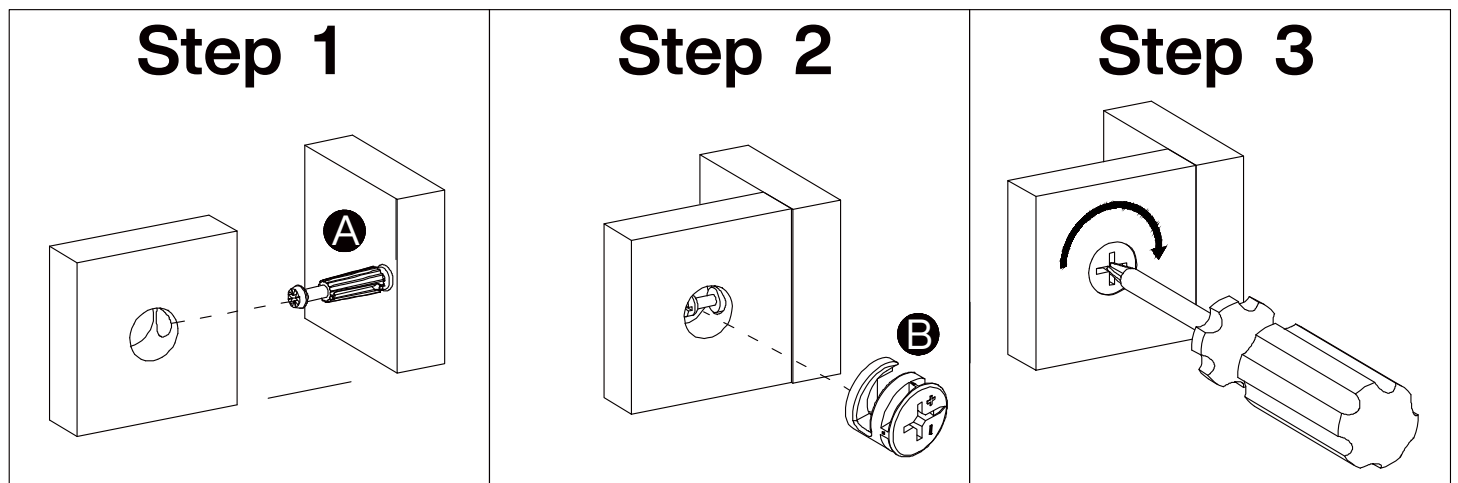

Screw the pin into the hole. Set the cams correctly by aligning the head of the cams with the lock pins. Lock the cam by turning the cam head with a screwdriver until it is tightened. Please do not use an electric screwdriver to assemble the unit.

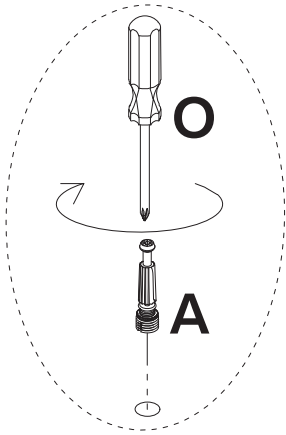
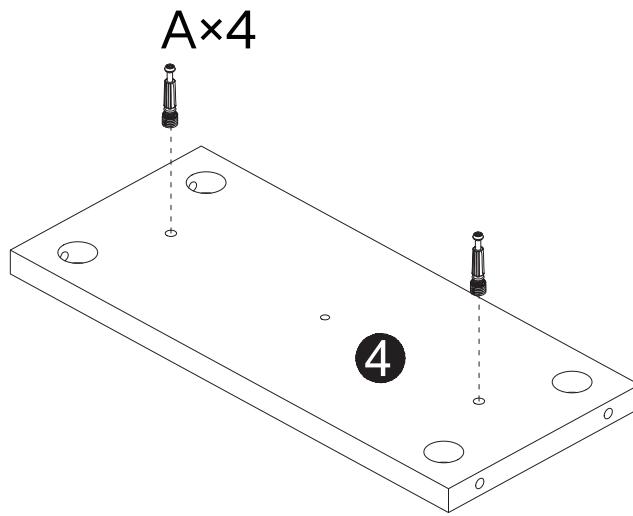

1

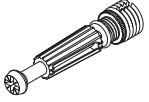

| |
|---|
| A |
|  |
| Ø6×40mm |
| 4 pcs |
| O |
|  |
| 1 pc |

x2

2

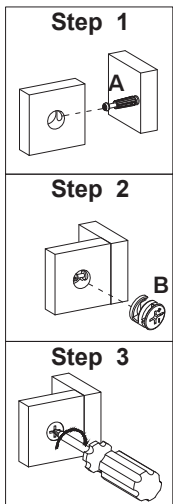
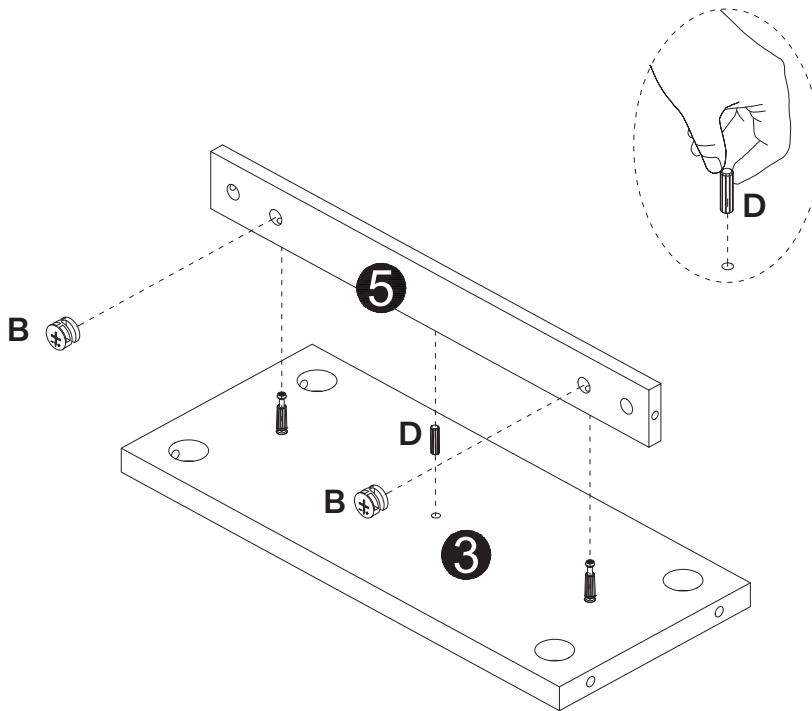

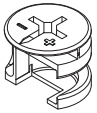
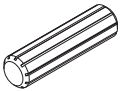
| |
|---|
| B |
|  |
| Ø15×12mm |
| 4 pcs |
| D |
|  |
| Ø8×30mm |
| 2 pcs |

x2

3

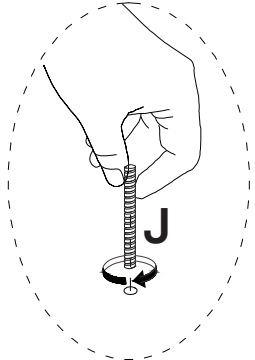
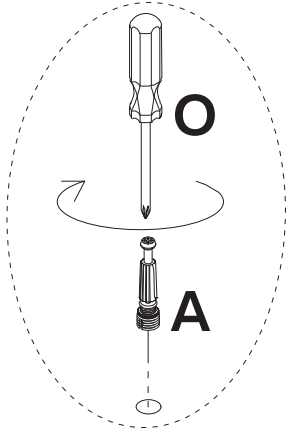
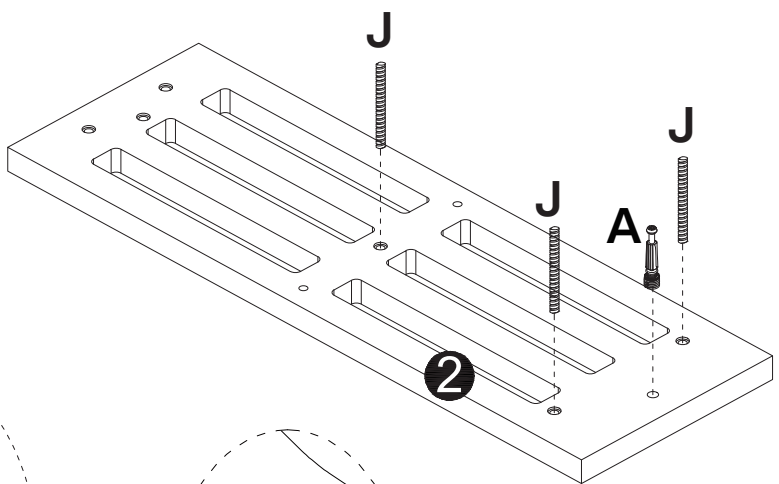

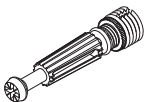
| |
|---|
| A |
|  |
| Ø6×40mm |
| 4 pcs |
| J |
|  |
| Ø8×60mm |
| 12 pcs |

x4

4

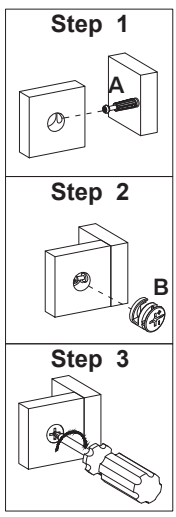
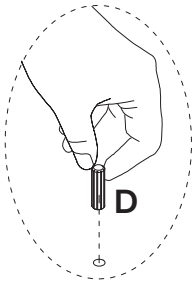
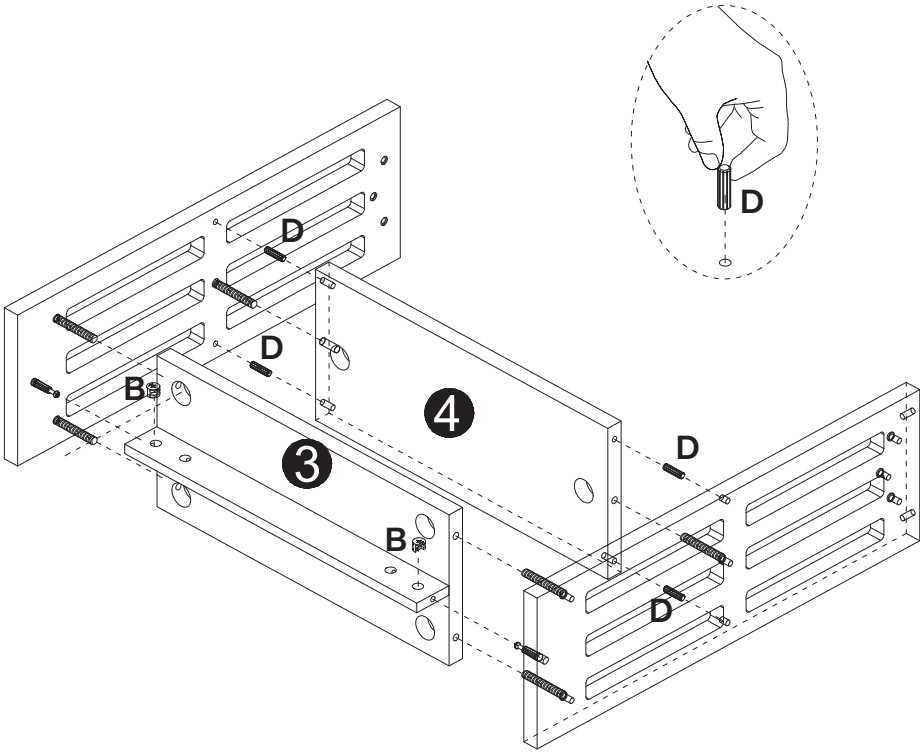

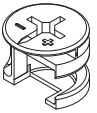
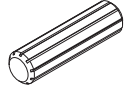

| |
|---|
| B |
|  |
| Ø15×12mm |
| 4 pcs |
| D |
|  |
| Ø8×30mm |
| 8 pcs |

x2

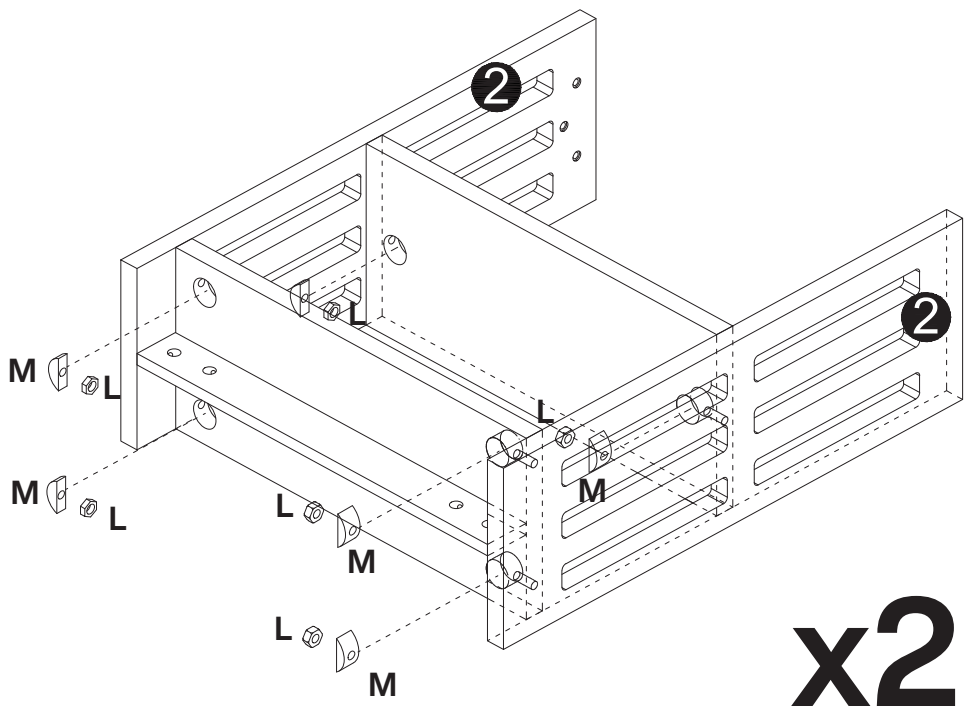
5



| |
|---|
| L |
|  |
| M8 |
| 12 pcs |
| M |
|  |
| M8 |
| 12 pcs |
| Q |
|  |
| M8 |
| 1 pc |

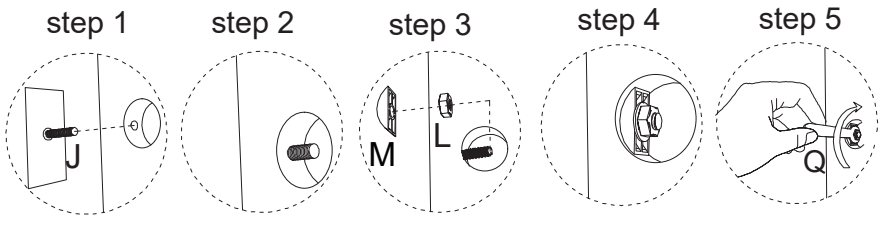

6

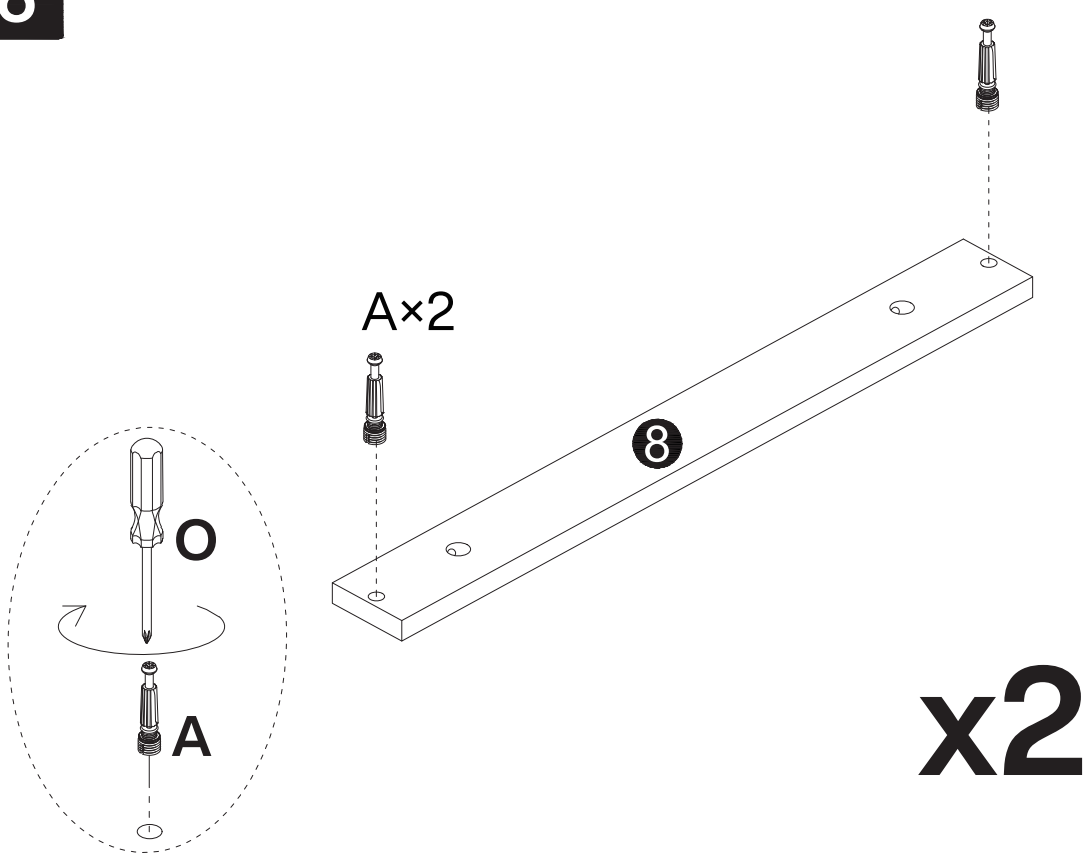

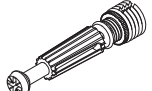
| |
|---|
| A |
|  |
| Ø6×40mm |
| 4 pcs |

7

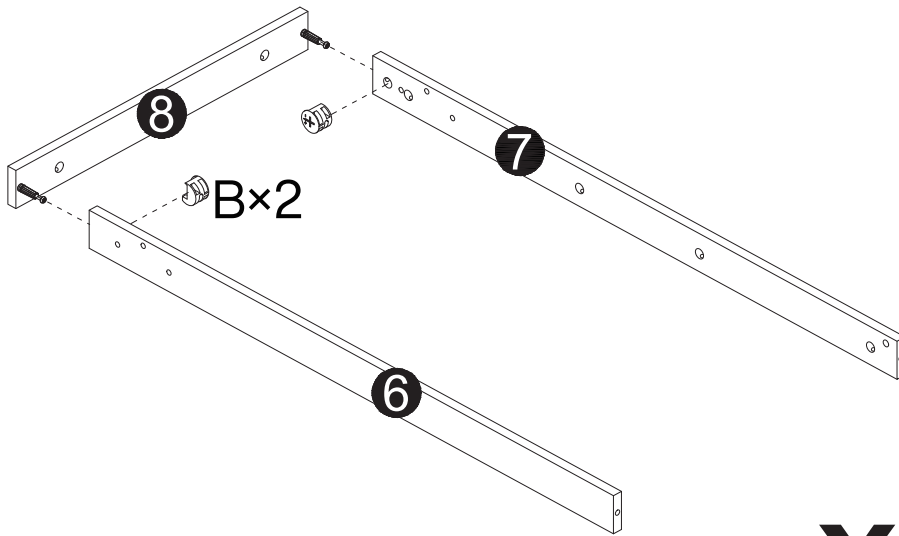

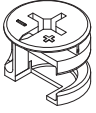
| |
|---|
| B |
|  |
| Ø15×12mm |
| 4 pcs |

Step 1

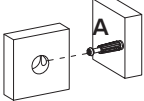

Step 2

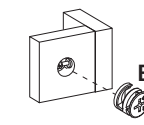

Step 3

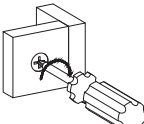

x2

8

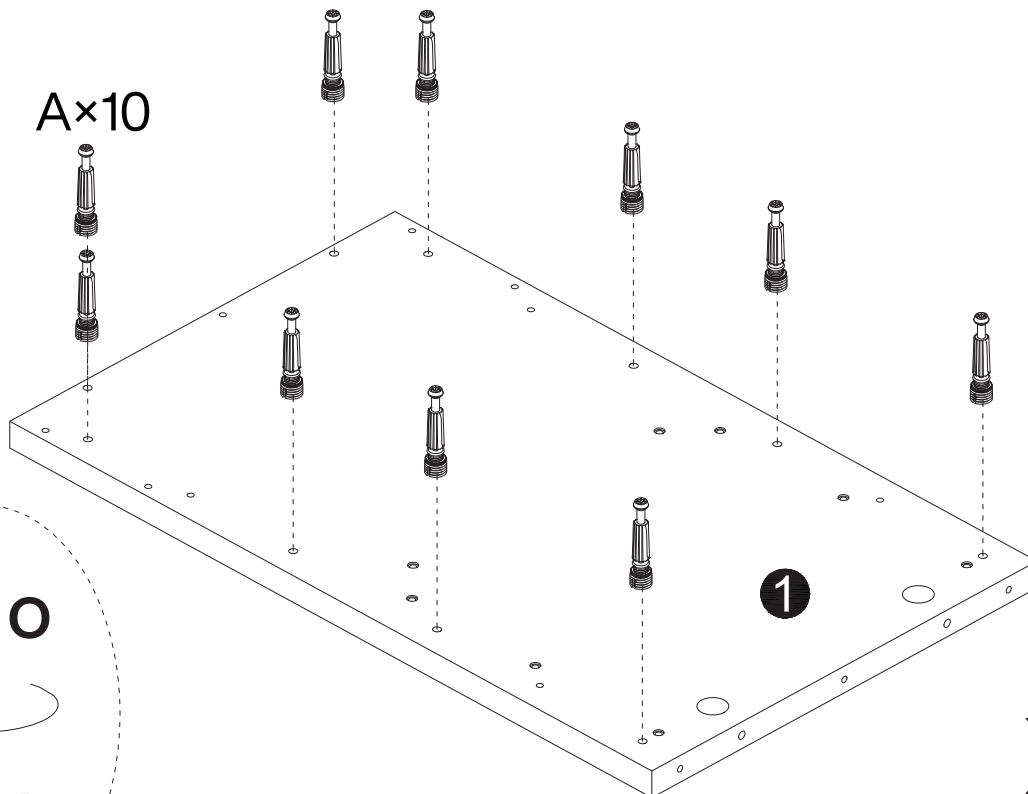

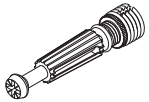
| |
|---|
| A |
|  |
| Ø6×40mm |
| 20 pcs |

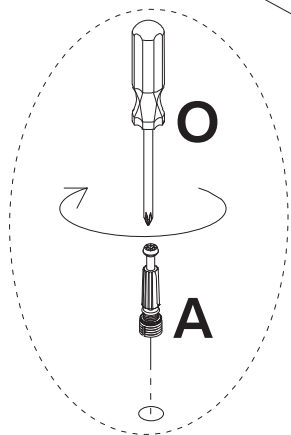

x2

9

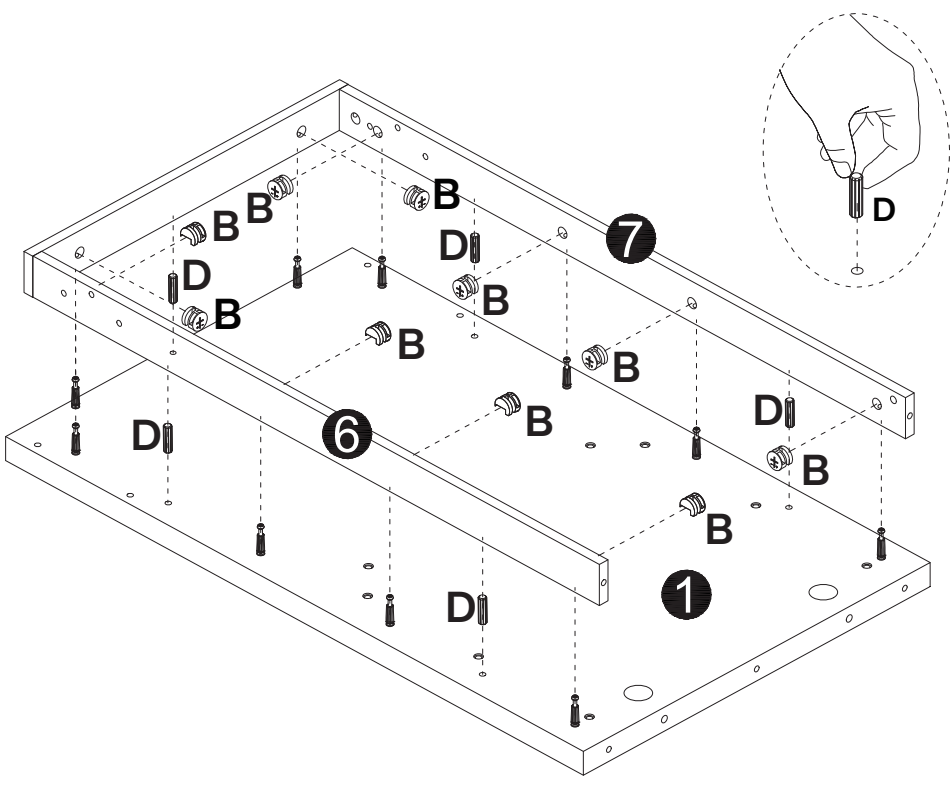

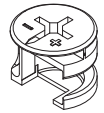
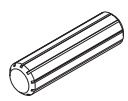

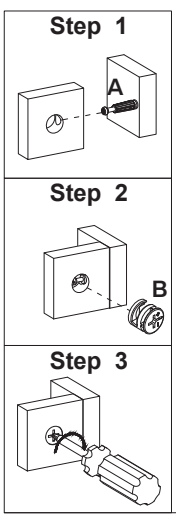

| |
|---|
| B |
|  |
| Ø15×12mm 20 pcs |
| D |
|  |
| Ø8×30mm 10 pcs |

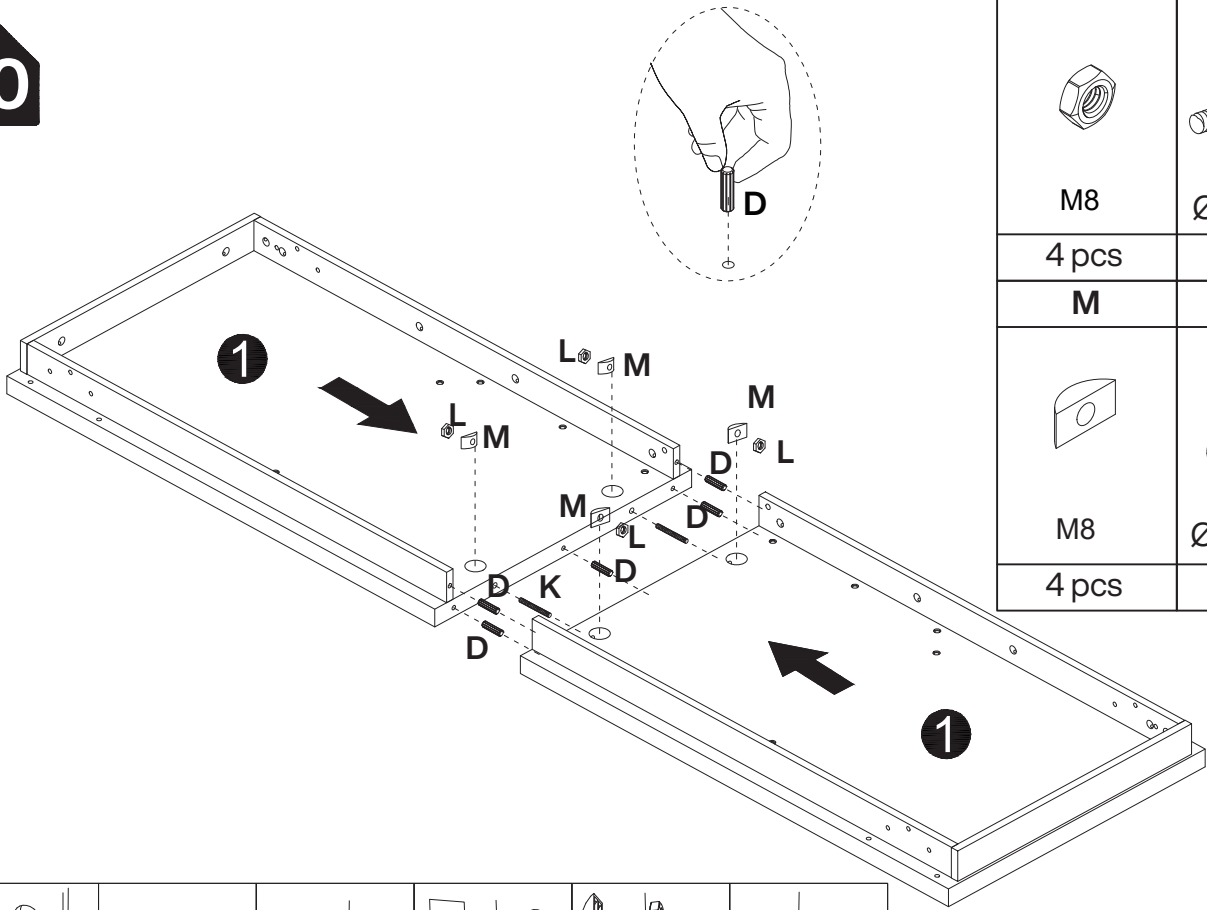

x2

10

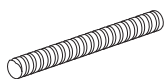

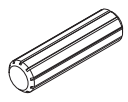
| | |
|---|---|
| L | K |
|  |  |
| M8 4 pcs | Ø8×90mm 2 pcs |
| M | D |
|  |  |
| M8 4 pcs | Ø8×30mm 5 pcs |

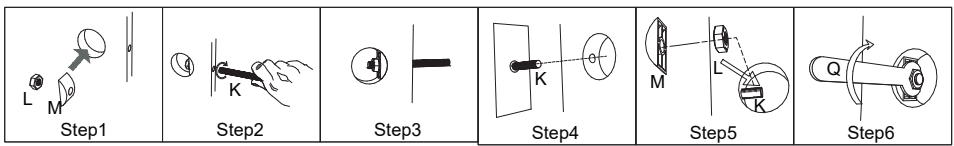

11

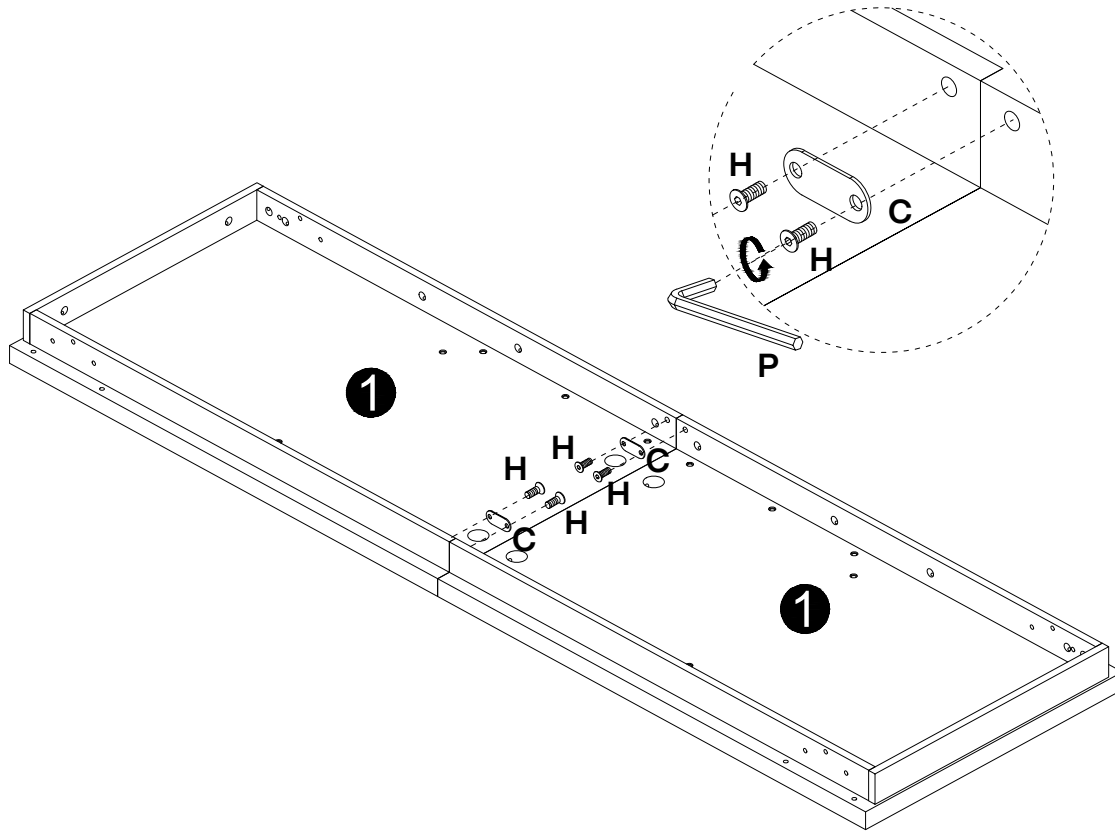

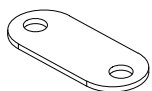
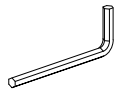
| |
|---|
| H |
|  |
| Ø6×10mm |
| 4 pcs |
| C |
|  |
| 2 pcs |
| P |
|  |
| M3 |
| 1 pc |

12

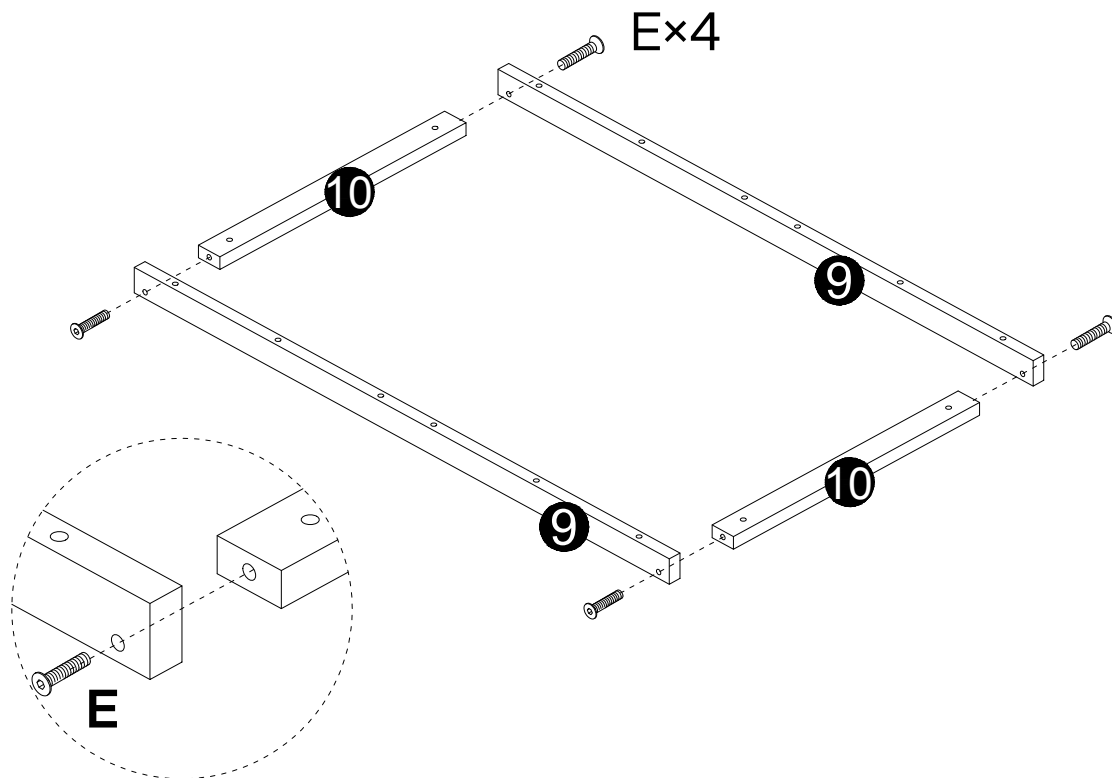

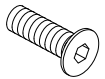
| |
|---|
| E |
|  |
| Ø6×35mm |
| 4 pcs |

⚠ Screw M6×35mm

13

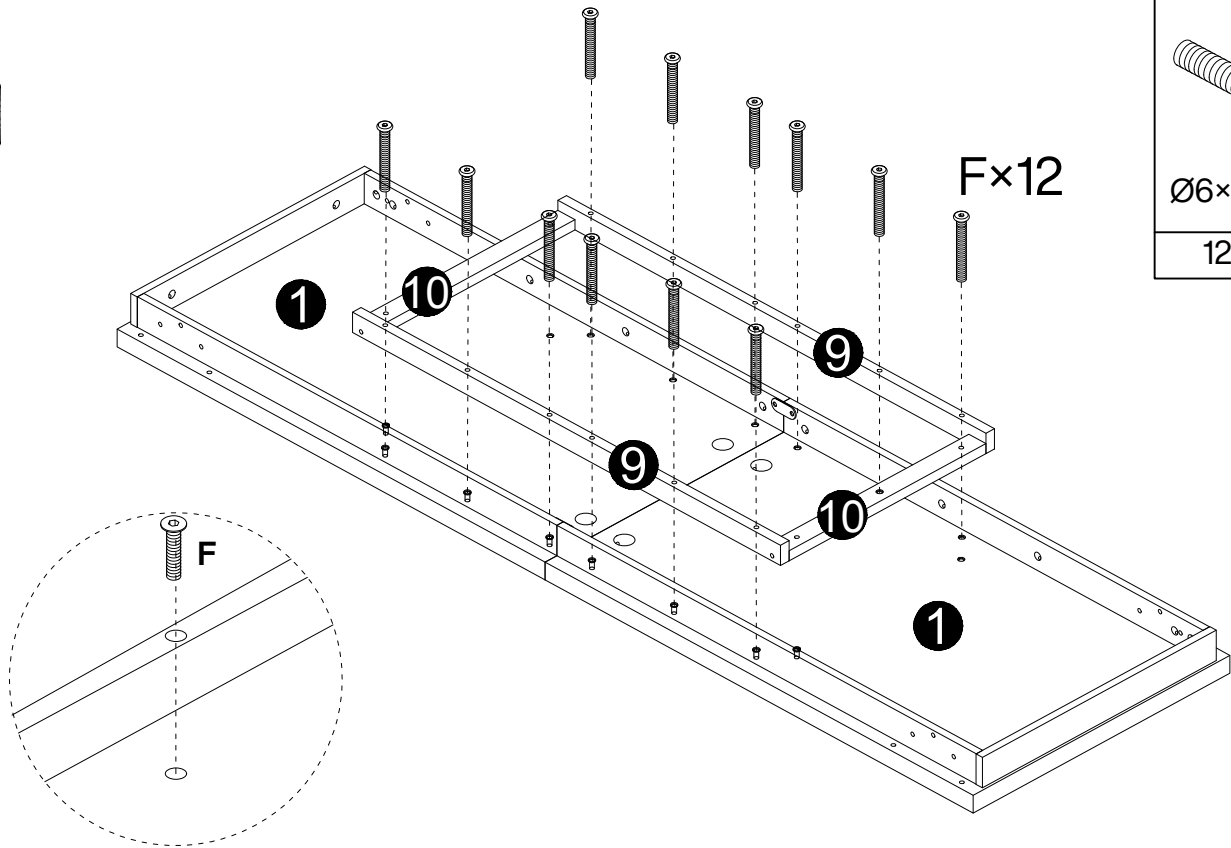

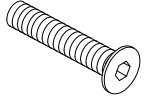
| |
|---|
| F |
|  |
| Ø6×55mm |
| 12 pcs |

F×12

⚠ Screw M6×55mm

14

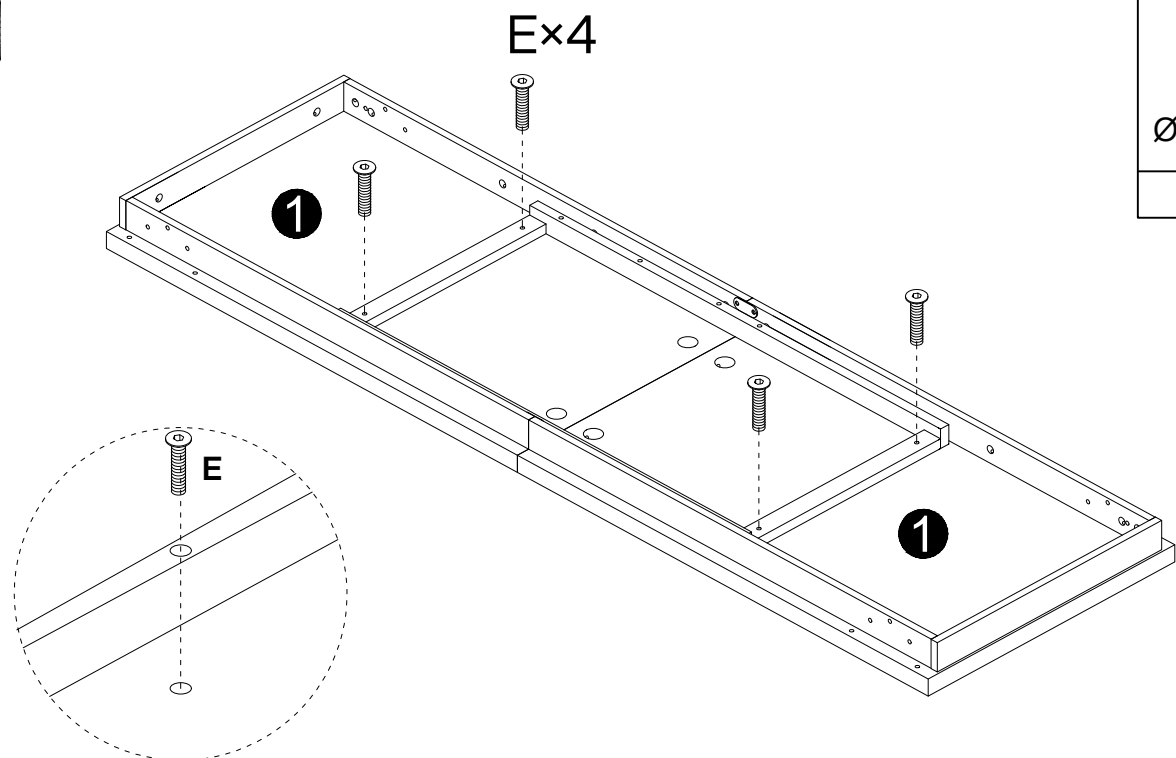

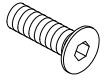

| |
|---|
| E |
|  |
| Ø6×35mm |
| 4 pcs |

E×4

⚠ Screw M6×35mm

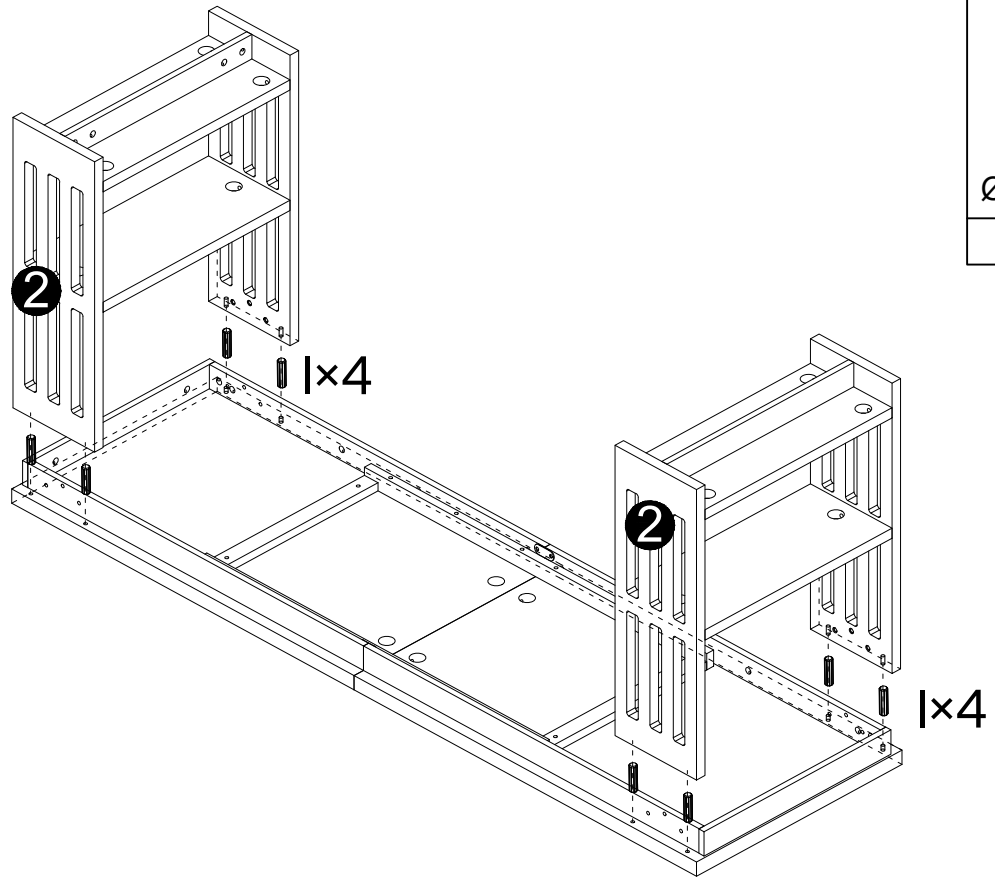
15



| |
|---|
| I |
|  |
| Ø10×40mm |
| 8 pcs |

16

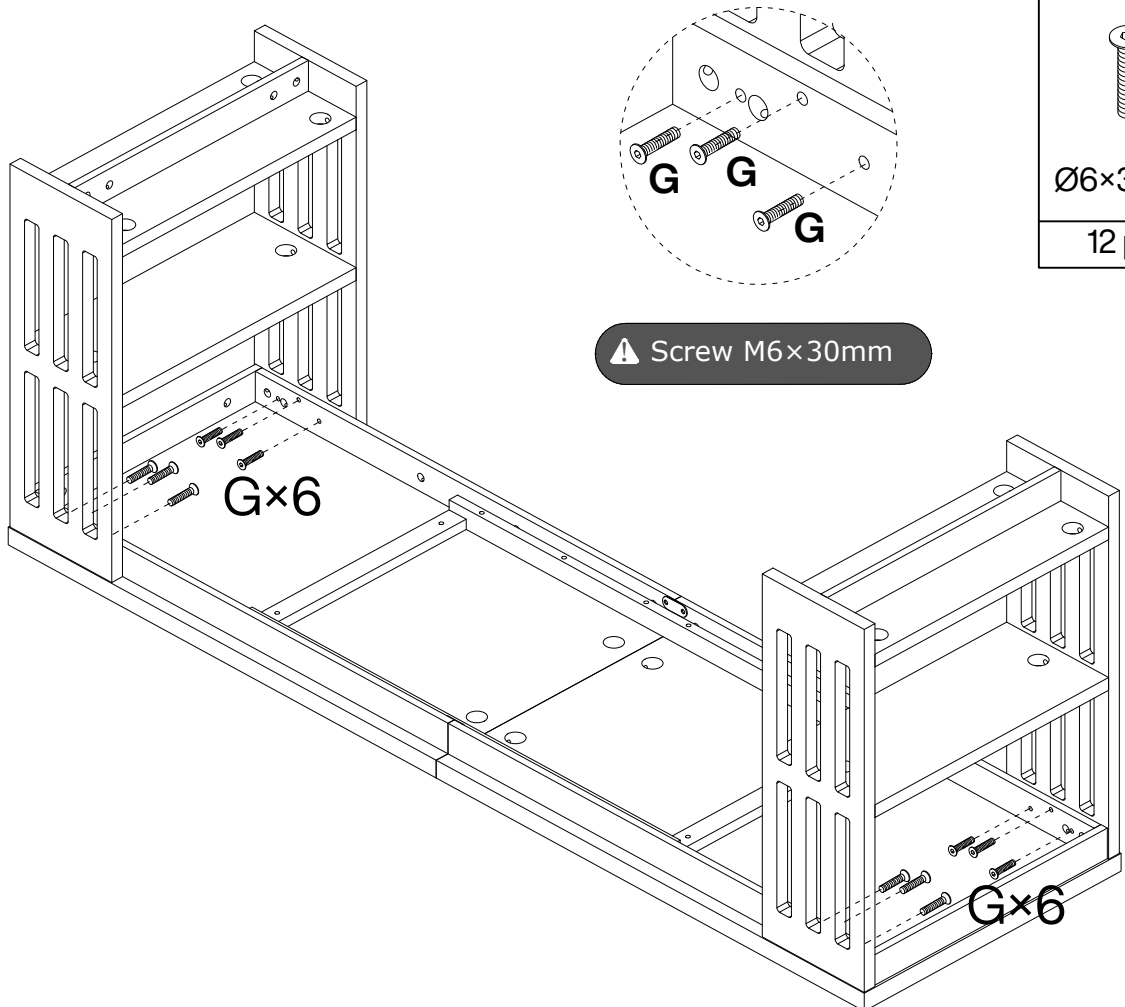

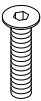
| |
|---|
| G |
|  |
| Ø6×30mm |
| 12 pcs |

⚠ Screw M6×30mm

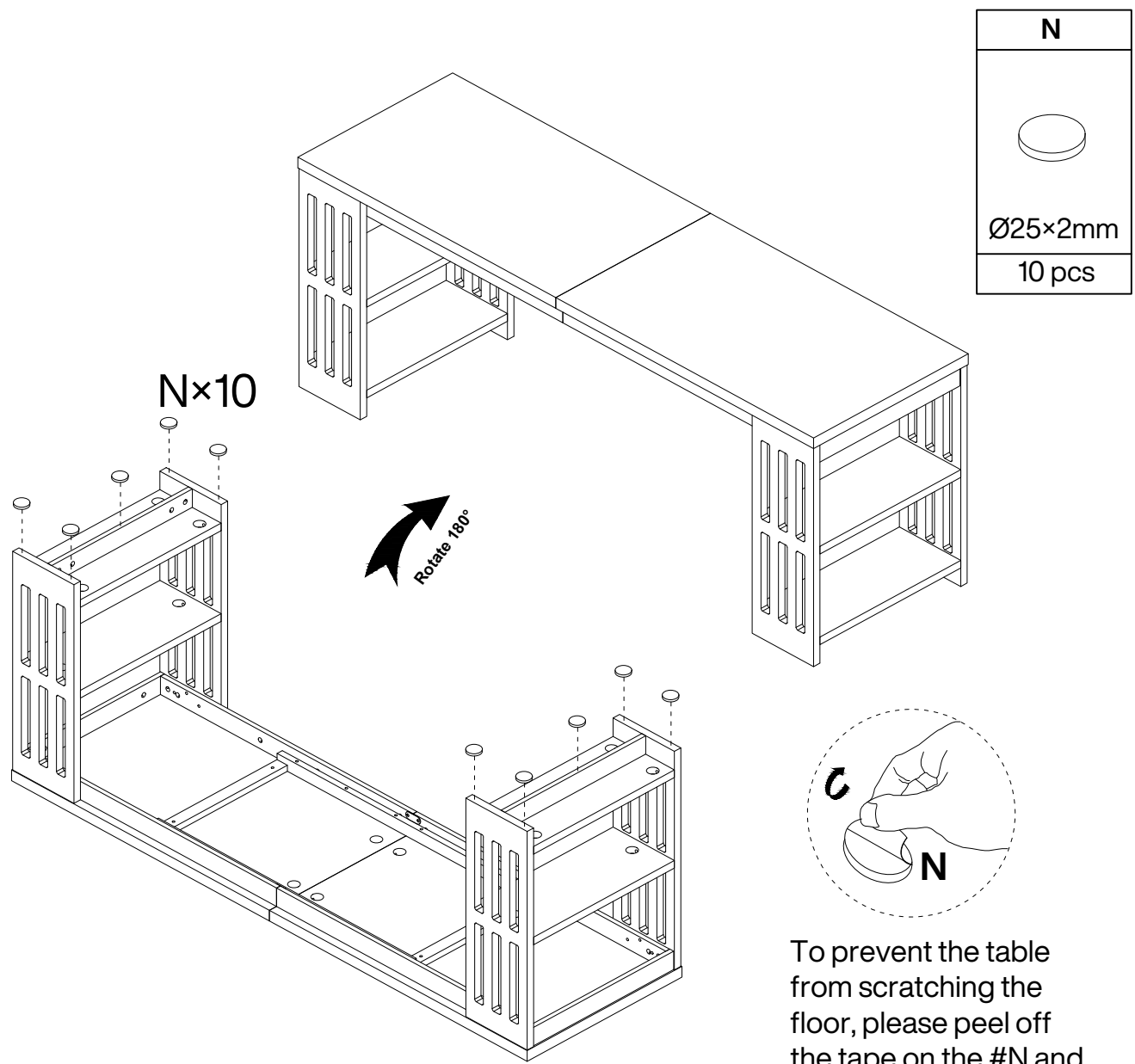

To prevent the table from scratching the floor, please peel off the tape on the #N and tape them to the corners of the table before use.

Thank you for your support!

