

! "IMPORTANT, RETAIN FOR FUTURE REFERENCE: READ CAREFULLY"
 German: WICHTIG, FÜR SPÄTERE NACHSCHLAGE AUFBEWAHREN: SORGFÄLTIG LESEN
 Spanish: IMPORTANTE, GUARDAR PARA REFERENCIA FUTURA: LEER ATENTAMENTE
 Italian: IMPORTANTE, CONSERVARE PER RIFERIMENTI FUTURI: LEGGERE ATTENTAMENTE
 French: IMPORTANT, À CONSERVER POUR RÉFÉRENCE FUTURE : LIRE ATTENTIVEMENT

1. Two or more people are required for assembly.
2. To avoid squeaking, please tighten the bolts all the way. Using an electric drill is recommended.
3. Professional installation is highly recommended.

1. Für den Zusammenbau werden zwei oder mehr Personen benötigt.
2. Um Quietschgeräusche zu vermeiden, ziehen Sie die Schrauben bitte ganz fest. Die Verwendung einer elektrischen Bohrmaschine wird empfohlen.
3. Ein fachgerechter Einbau wird dringend empfohlen.

1. Il faut au moins deux personnes pour le montage.
2. Pour éviter tout grincement, veuillez serrer les boulons à fond. Il est recommandé d'utiliser une perceuse électrique.
3. Une installation professionnelle est fortement recommandée.

1. E' necessario due o più persone per l'installazione.
2. Per evitare cigolii, serrare bene i bulloni. Si consiglia di utilizzare un trapano elettrico.
3. Si consiglia vivamente un'installazione professionale.

1. Se necesitan dos o más personas para el montaje.
2. Para evitar chirridos, apriete todos los tornillos. Se recomienda utilizar un taladro eléctrico.
3. Se recomienda encarecidamente la instalación profesional.

Tools Required For Assembly
Für die Montage benötigte Werkzeuge
Outil Nécessaire Pour Le Montage
Strumenti necessari per il montaggio
Herramientas requeridas para el montaje

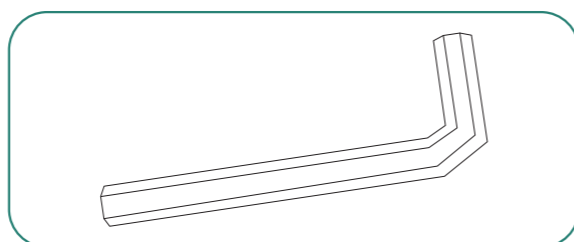

Item no. Nr. N° d'article Articolo No. Artículo No.	Reference Image Referenzbild Image de référence Immagine di riferimento Imagen de referencia	Qty. Menge Qté. Qtà Cant.
A		X 1
A1		X 1

Item no. Nr. N° d'article Articolo No. Artículo No.	Reference Image Referenzbild Image de référence Immagine di riferimento Imagen de referencia	Qty. Menge Qté. Qtà Cant.	Item no. Nr. N° d'article Articolo No. Artículo No.	Reference Image Referenzbild Image de référence Immagine di riferimento Imagen de referencia	Qty. Menge Qté. Qtà Cant.
B		X 2	D		X 1
C		X 2	E		X 3

Item no. Nr. N° d'article Articolo No. Artículo No.	Reference Image Referenzbild Image de référence Immagine di riferimento Imagen de referencia	Qty. Menge Qté. Qtà Cant.
F	 S5	X 1
G	 M8X16mm	X 48
H		X 2
I		X 9
J		X 1
J1		X 1

Item no. Nr. N° d'article Articolo No. Artículo No.	Reference Image Referenzbild Image de référence Immagine di riferimento Imagen de referencia	Qty. Menge Qté. Qtà Cant.
K		X 1
O		X 2
P		X 2
L		X 2
M		X 1
N		X 1
Q		X 1
R		X 1
S		X 2
T		X 1

M3X6mm

S4

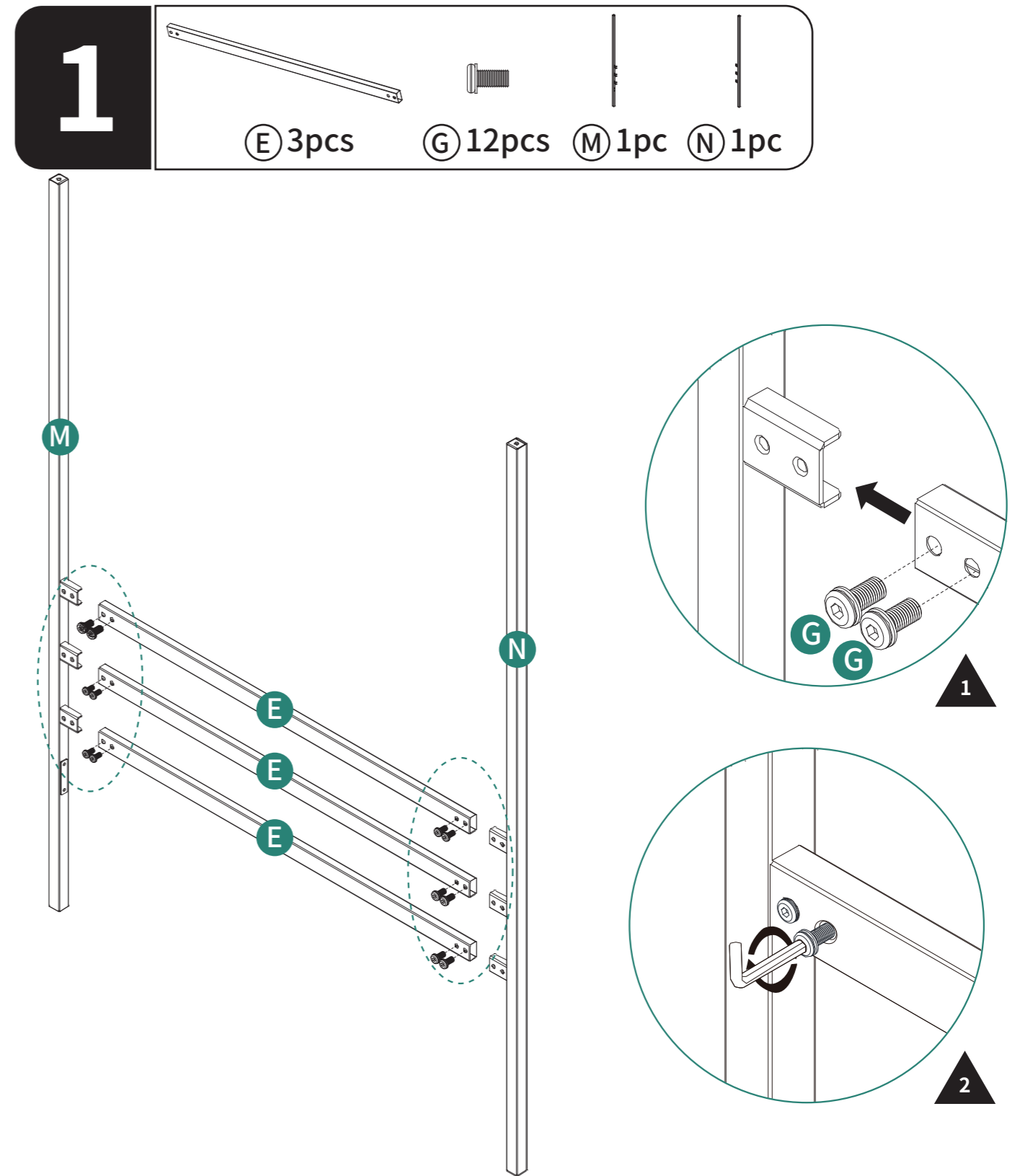

Do not fully tighten screws before completing step 2.

Vor Abschluss von Schritt 2 die Schrauben nicht vollständig festziehen.

Ne serrez pas complètement les vis avant d'avoir terminé l'étape 2.

Non stringere completamente le viti prima di completare il passaggio 2.

No apriete completamente los tornillos antes de completar el paso 2.

2

Ⓝ 1pc

Ⓞ 4pcs

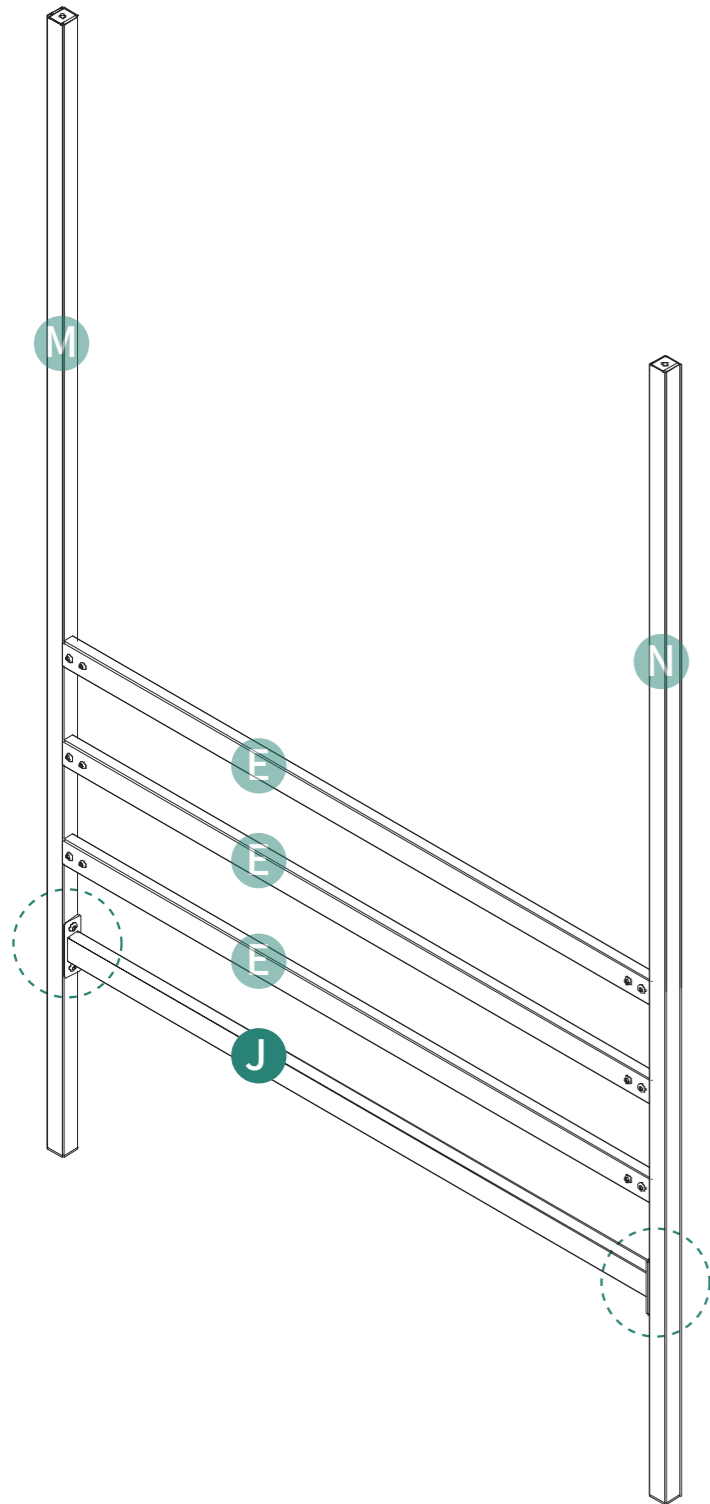
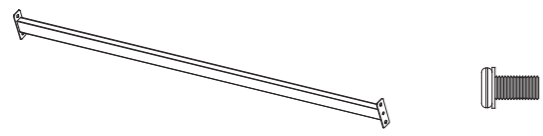

5

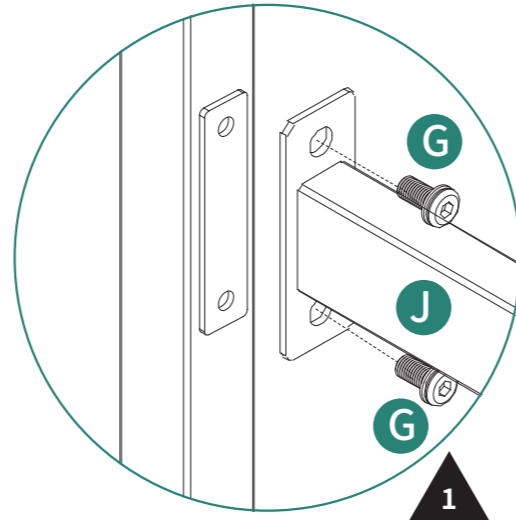

1

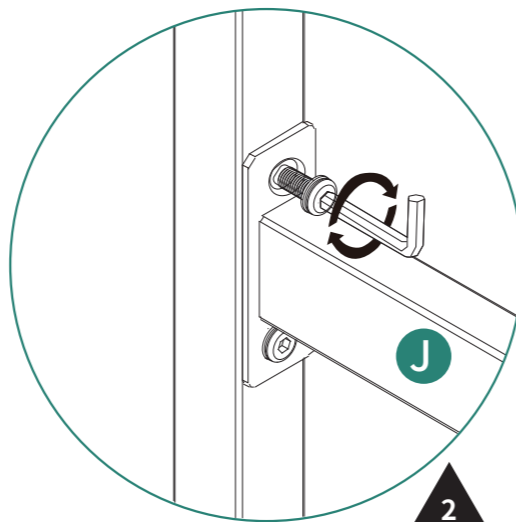

2

Further tighten the screw using a drill.
Ziehen Sie die Schraube mit einer Bohrmaschine weiter an.
Utilisez la perceuse électrique pour serrer davantage les vis.
Stringere bene la vite con un trapano.
Apriete los tornillos una vez más con el taladro eléctrico.

3

Ⓟ 2pcs

Ⓝ 1pc

Ⓞ 4pcs

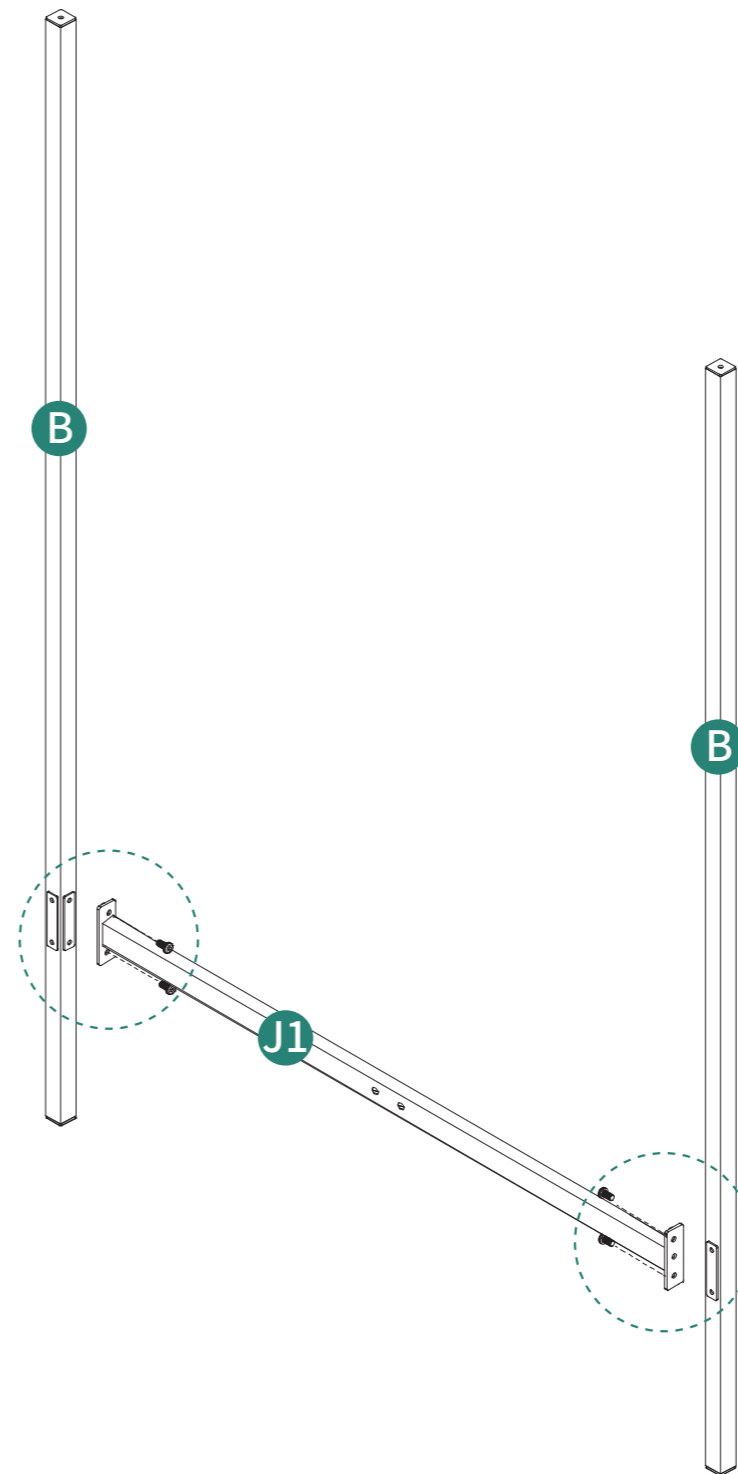
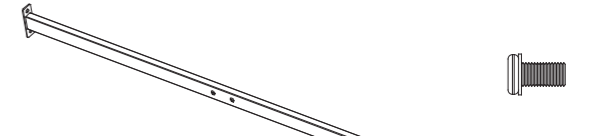

6

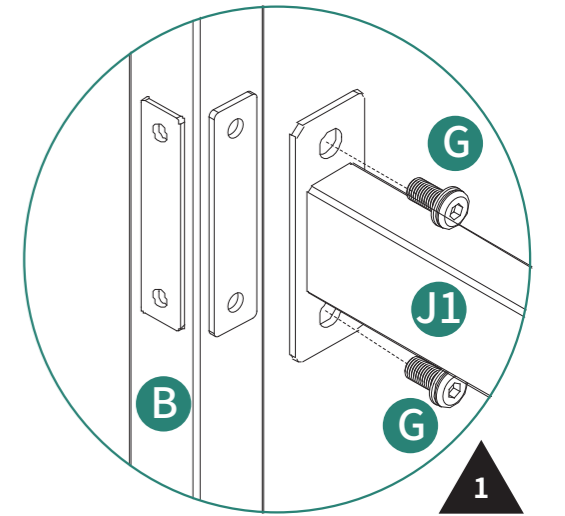

1

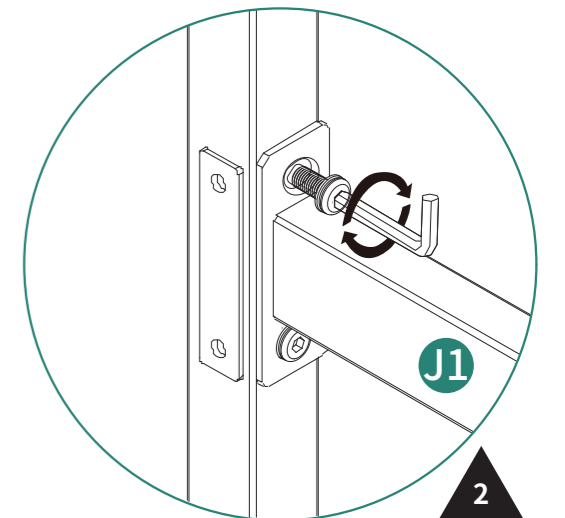

2

Further tighten the screw using a drill.
Ziehen Sie die Schraube mit einer Bohrmaschine weiter an.
Utilisez la perceuse électrique pour serrer davantage les vis.
Stringere bene la vite con un trapano.
Apriete los tornillos una vez más con el taladro eléctrico.

4

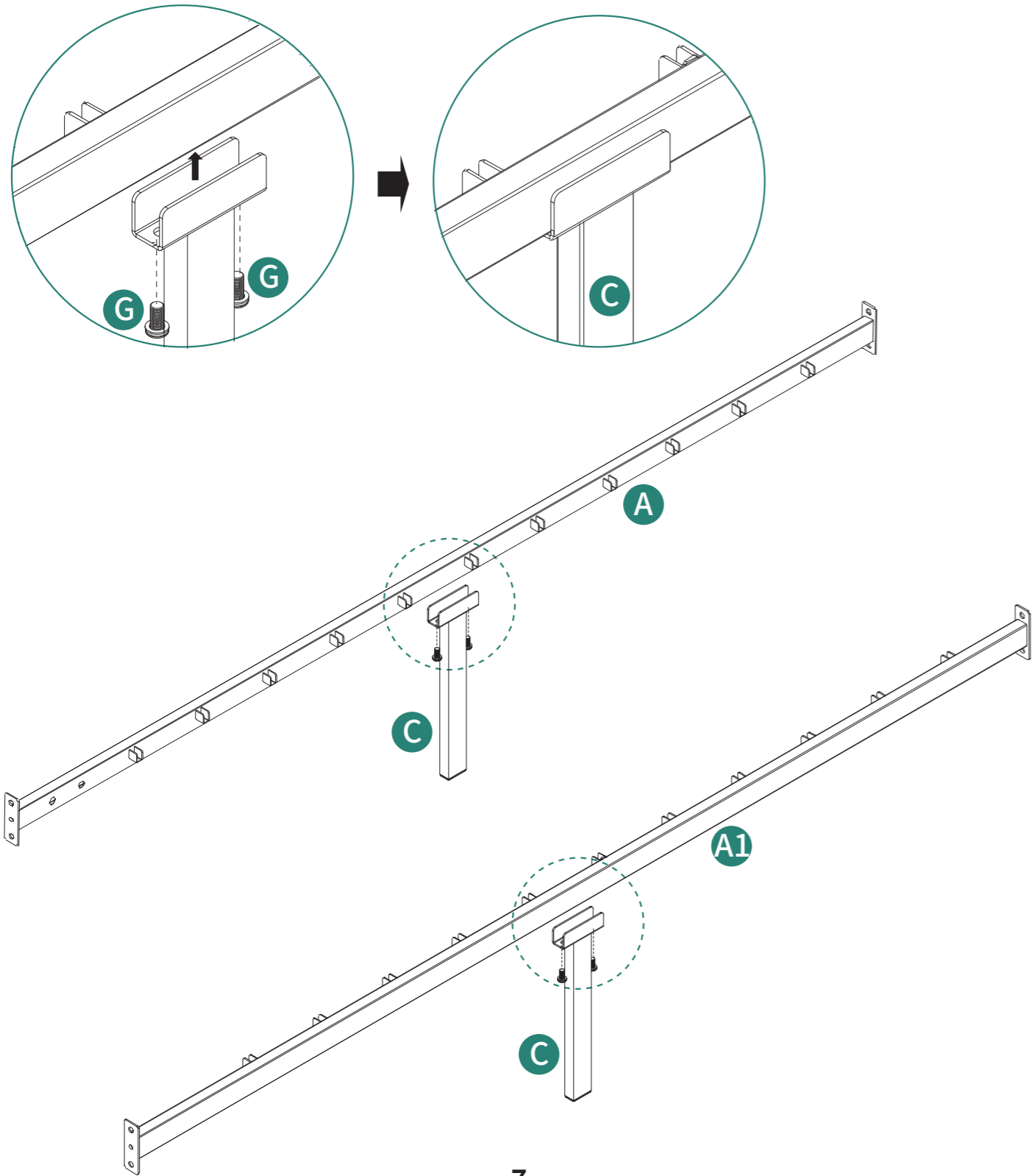
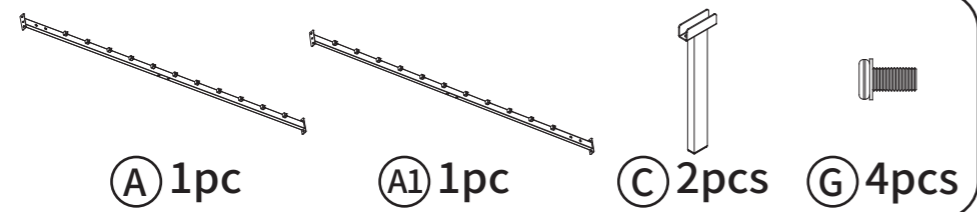

7

5

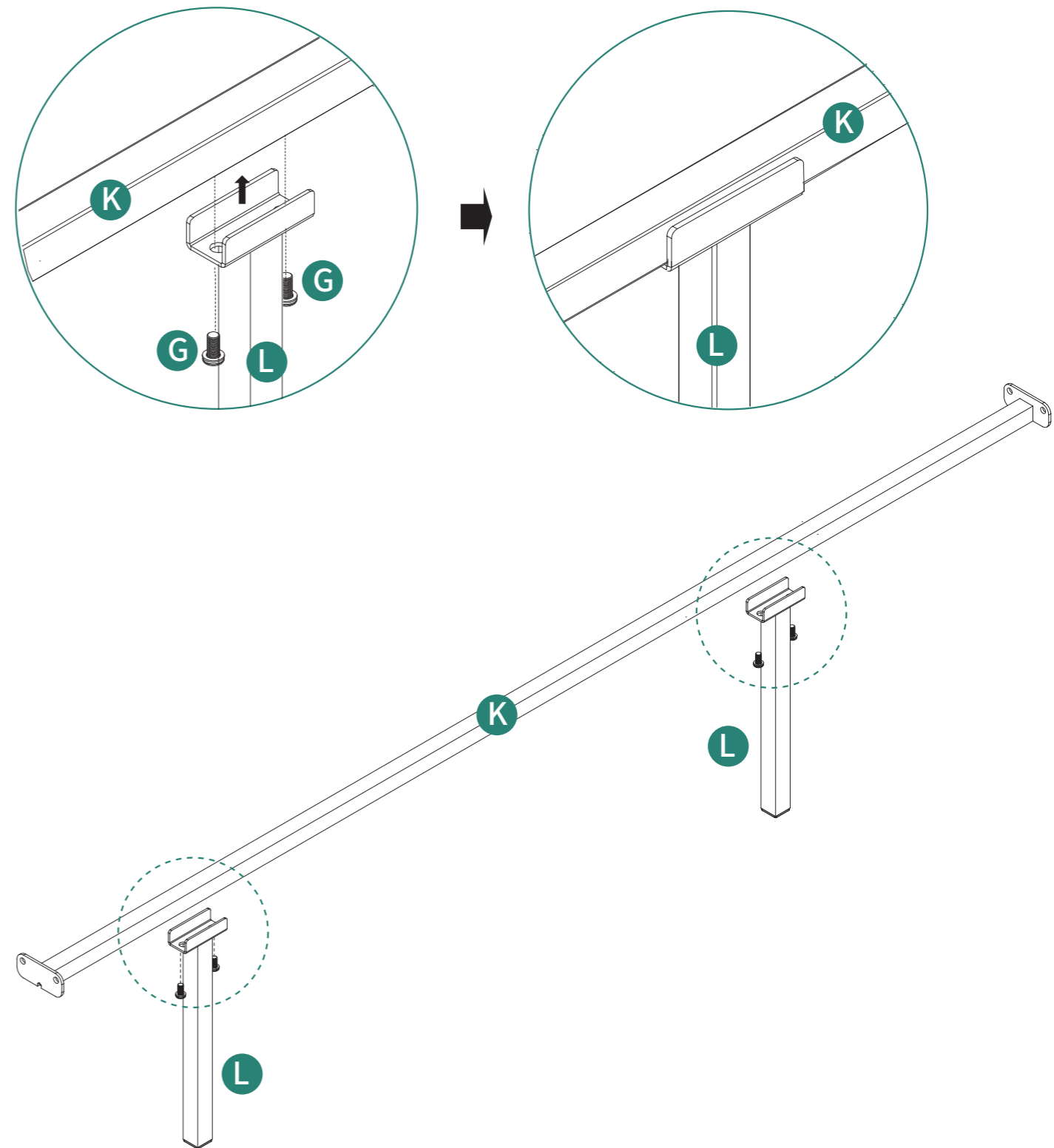
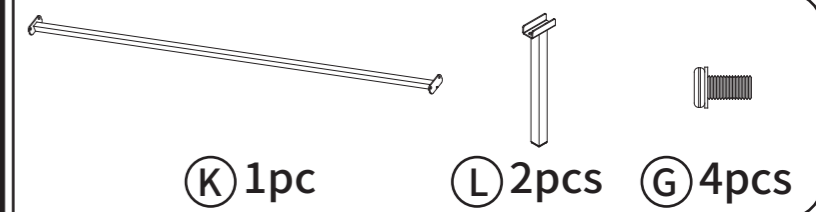

8

6

Ⓓ 1pc

Ⓔ 12pcs

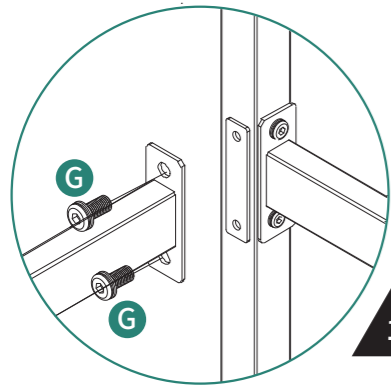
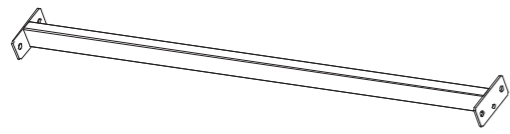

1

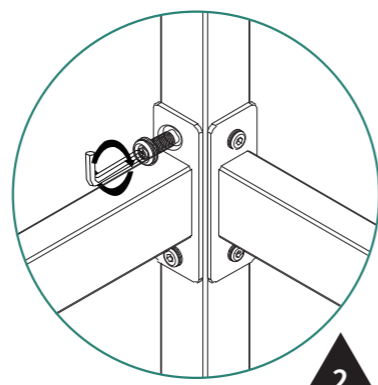

2

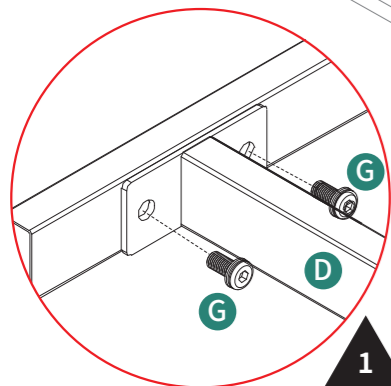
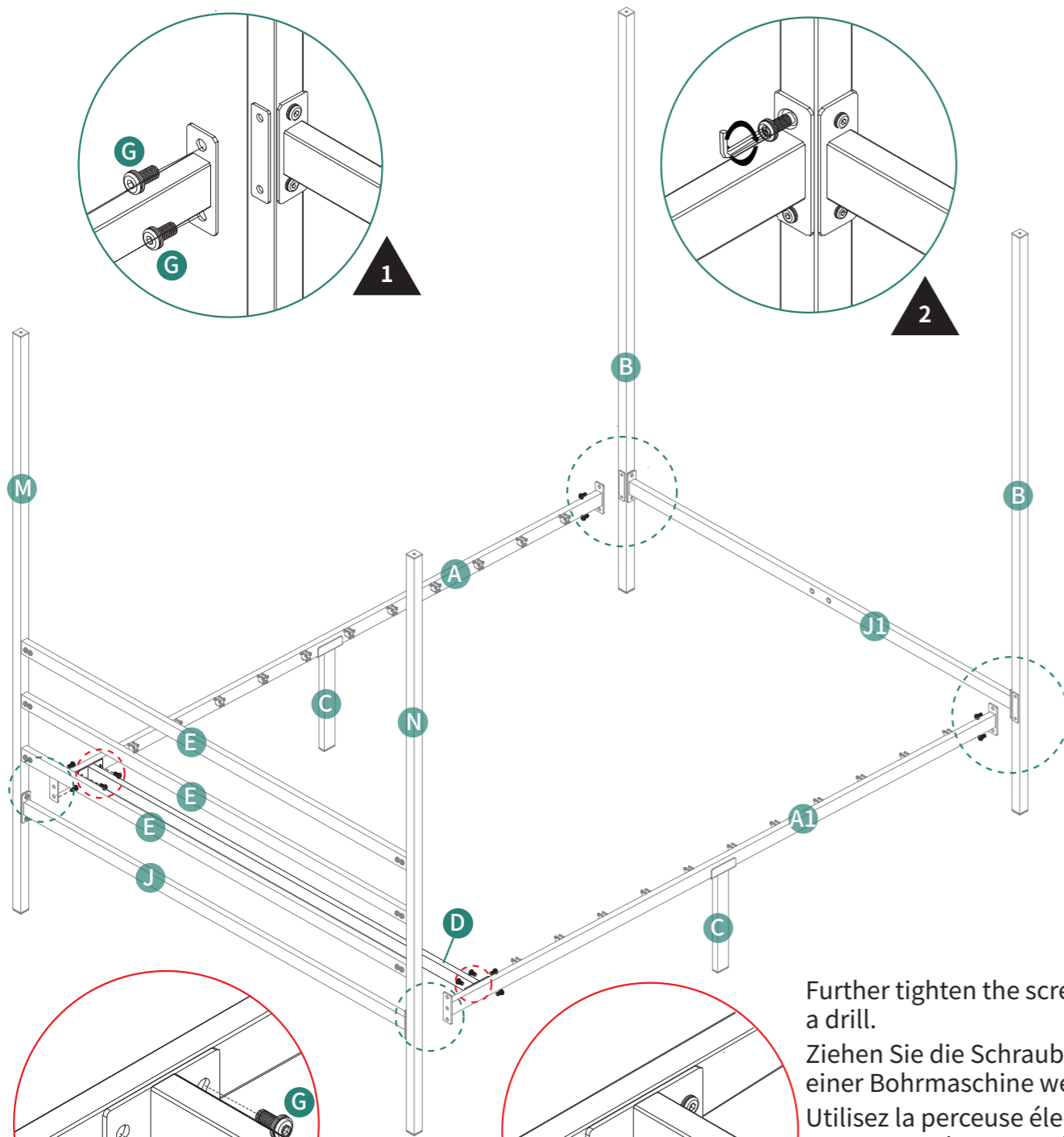

1

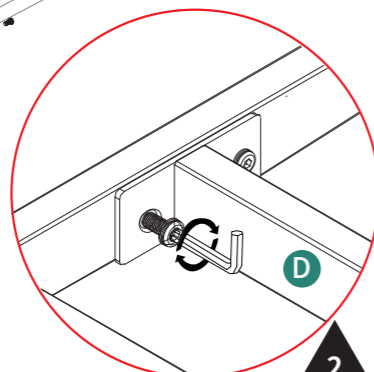

2

Further tighten the screw using a drill.
 Ziehen Sie die Schraube mit einer Bohrmaschine weiter an.
 Utilisez la perceuse électrique pour serrer davantage les vis.
 Stringere bene la vite con un trapano.
 Apriete los tornillos una vez más con el taladro eléctrico.

9

7

Ⓔ 4pcs

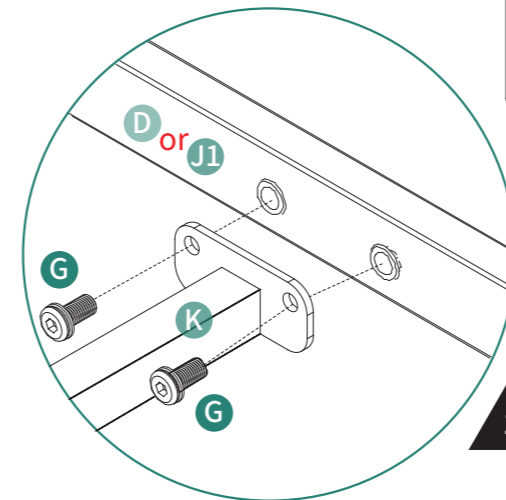
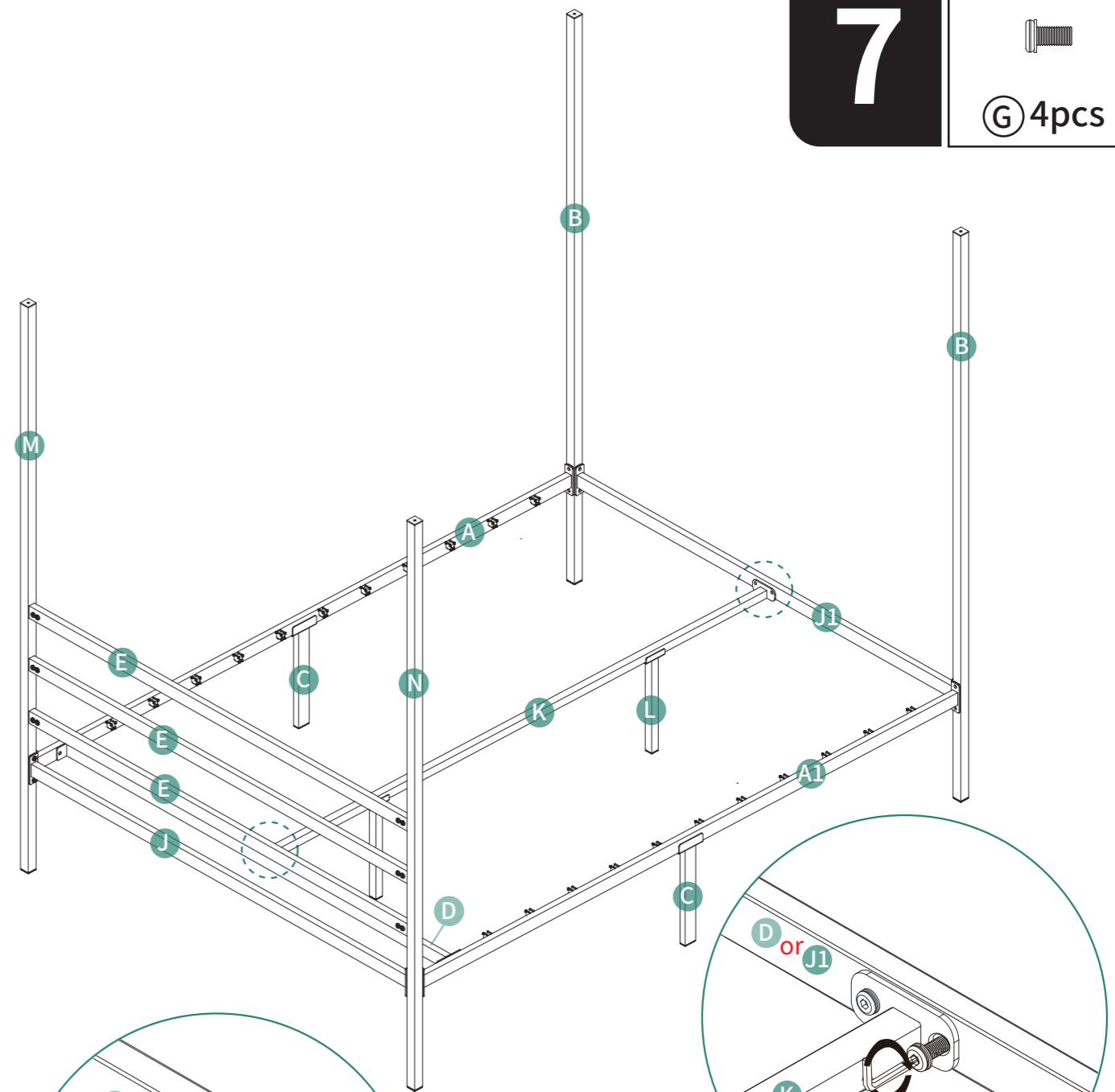

1

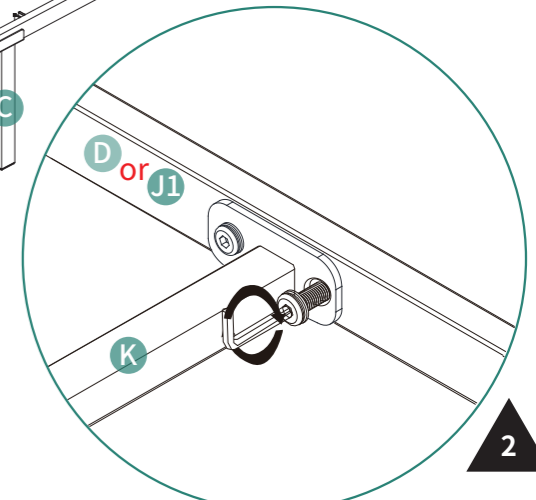

2

Further tighten the screw using a drill.
 Ziehen Sie die Schraube mit einer Bohrmaschine weiter an.
 Utilisez la perceuse électrique pour serrer davantage les vis.
 Stringere bene la vite con un trapano.
 Apriete los tornillos una vez más con el taladro eléctrico.

10

8

Ⓞ 2 pcs

Ⓟ 2 pcs

ⓖ 4 pcs

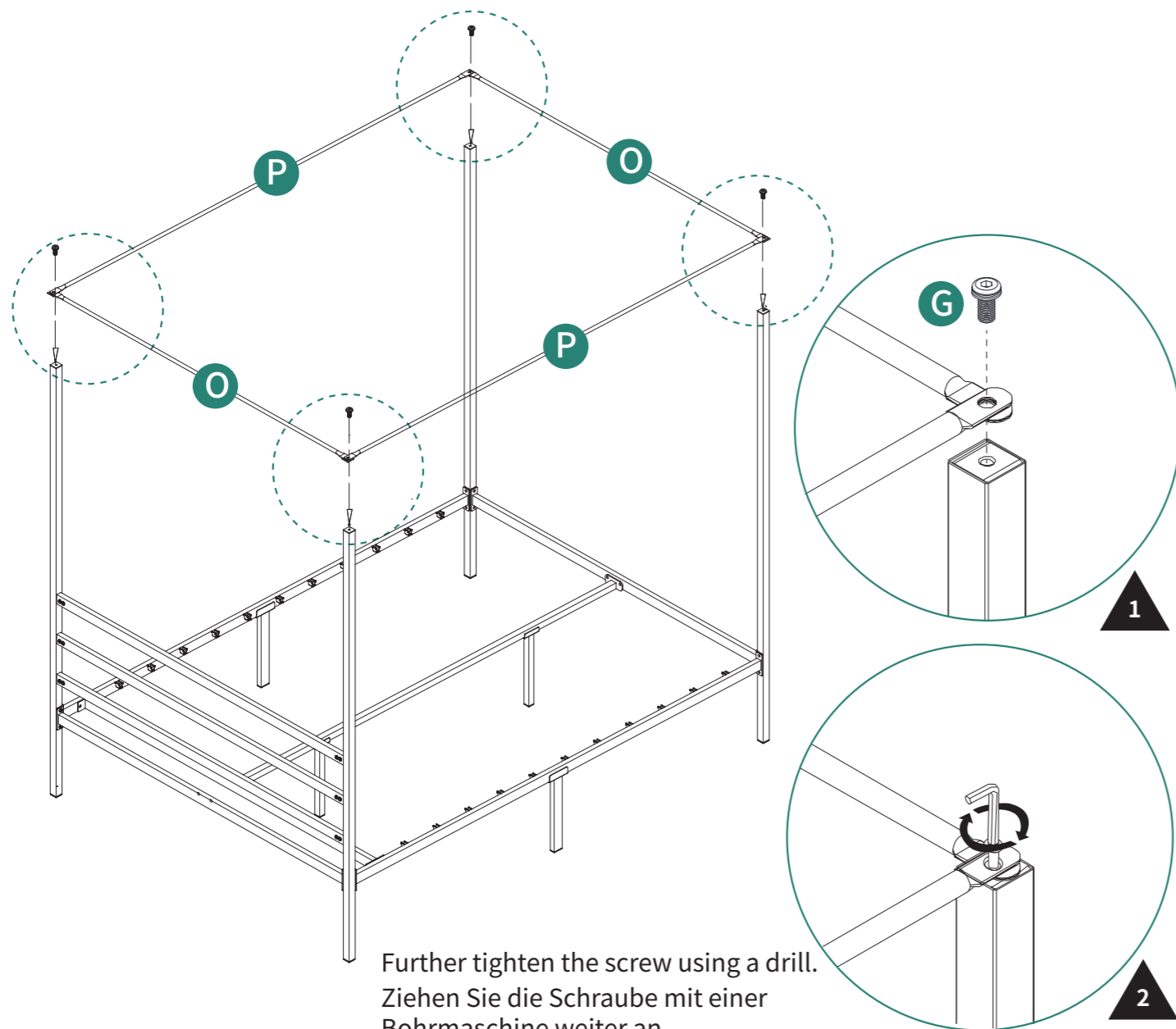

Further tighten the screw using a drill.
 Ziehen Sie die Schraube mit einer Bohrmaschine weiter an.
 Utilisez la perceuse électrique pour serrer davantage les vis.
 Stringere bene la vite con un trapano.
 Apriete los tornillos una vez más con el taladro eléctrico.

11**9**

ⓗ 2 pcs

Ⓢ 9 pcs

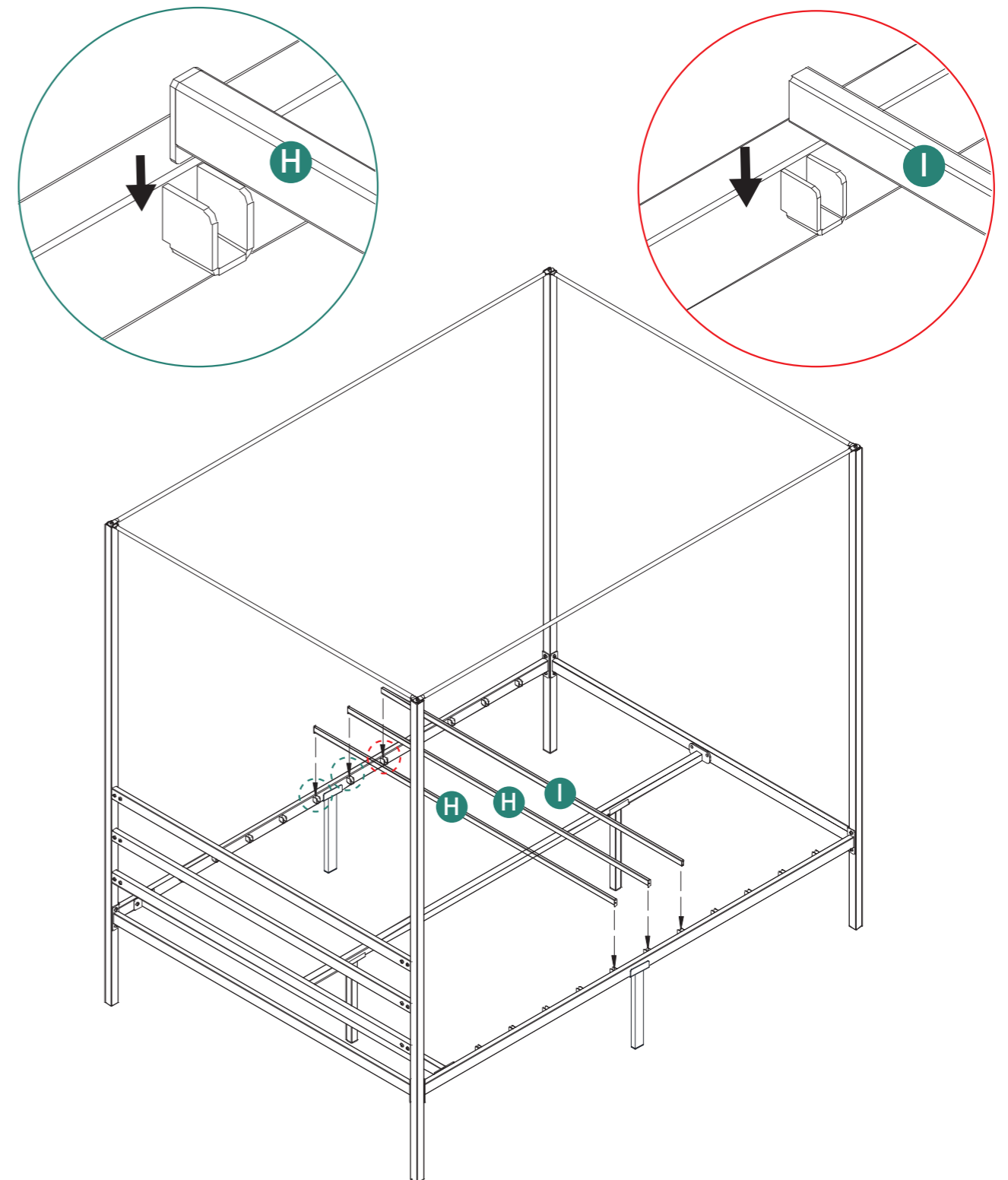
**12**

10

H-type steel slats can be installed into any side groove and provide solid support for the bed frame.

H-Stahl-Latten können in jede Seitennut eingesetzt werden und geben dem Bettrahmen einen festen Halt.

Les barres de la plaque en H peuvent être installées dans les évidements de chaque côté afin de fournir un support solide pour le cadre du lit.

Le doghe in acciaio di tipo H possono essere installate in qualsiasi scanalatura laterale e forniscono un solido supporto per il giroletto.

Las barras de la placa H pueden instalarse en cualquier ranura lateral para proporcionar un soporte sólido para el marco de la cama.

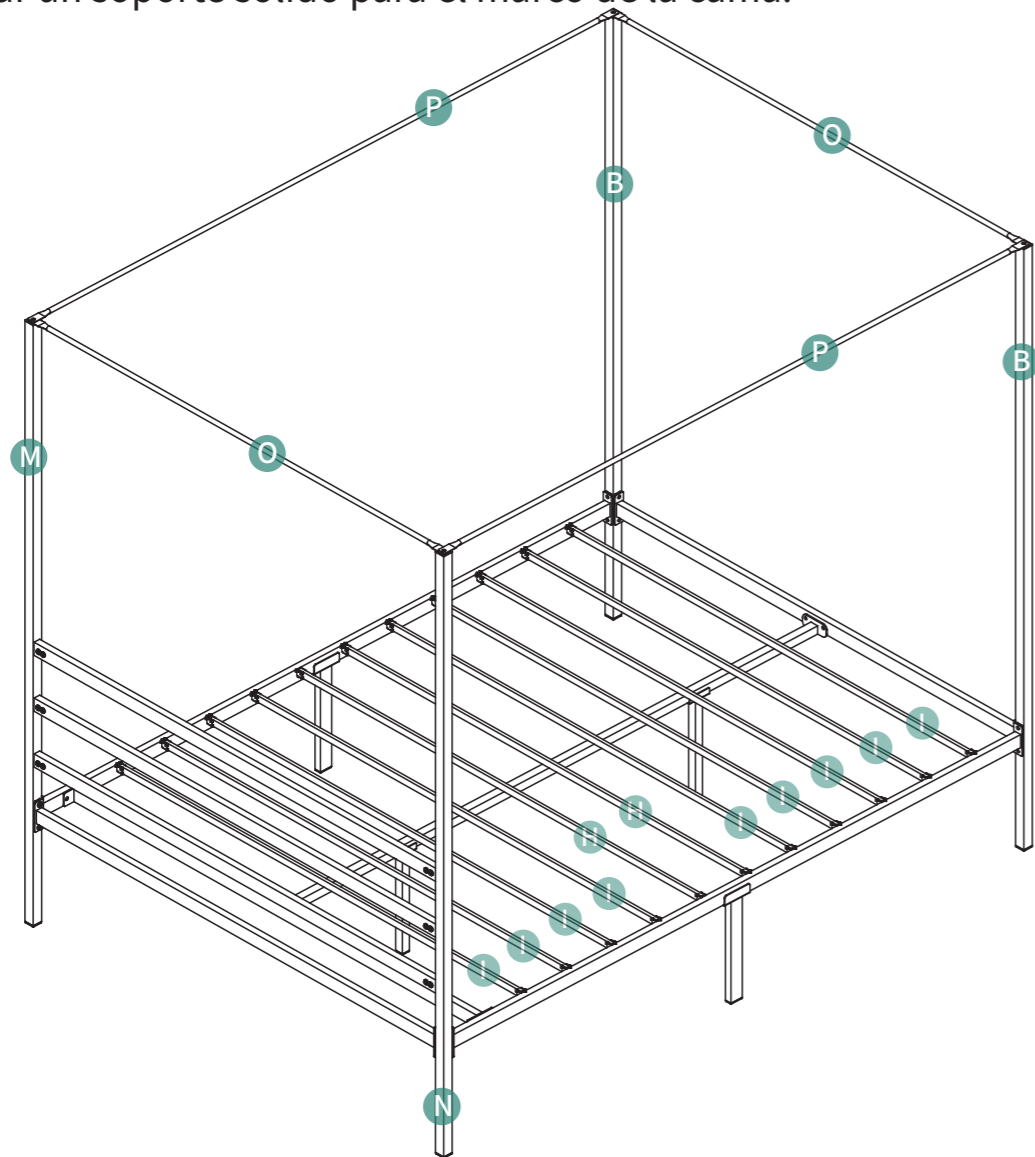

13

11

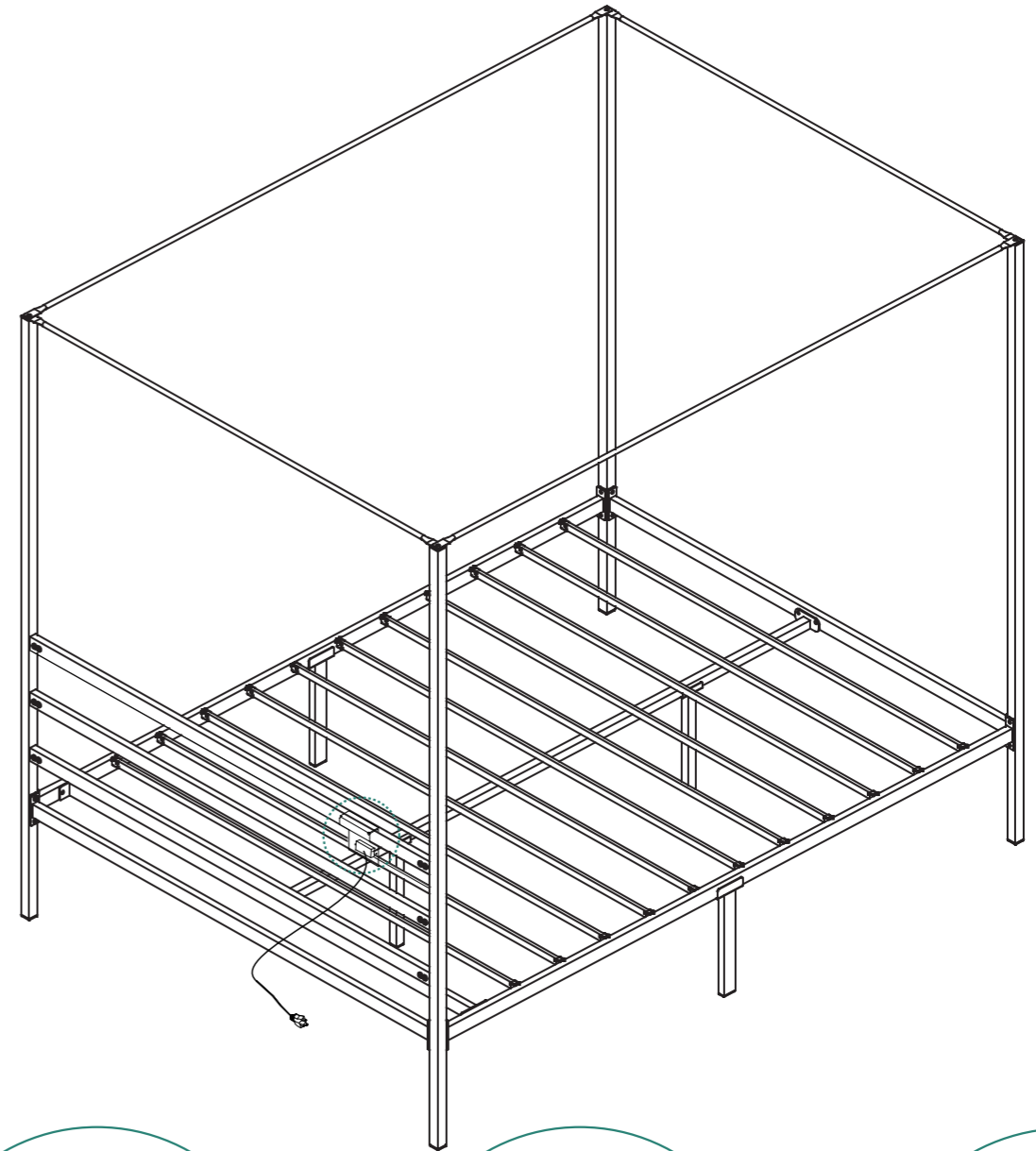
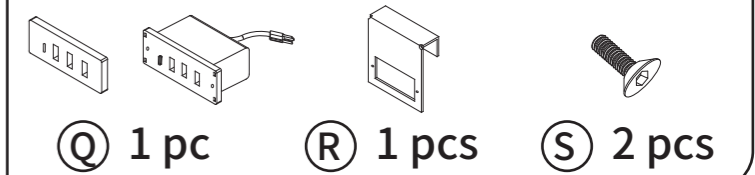

14

12

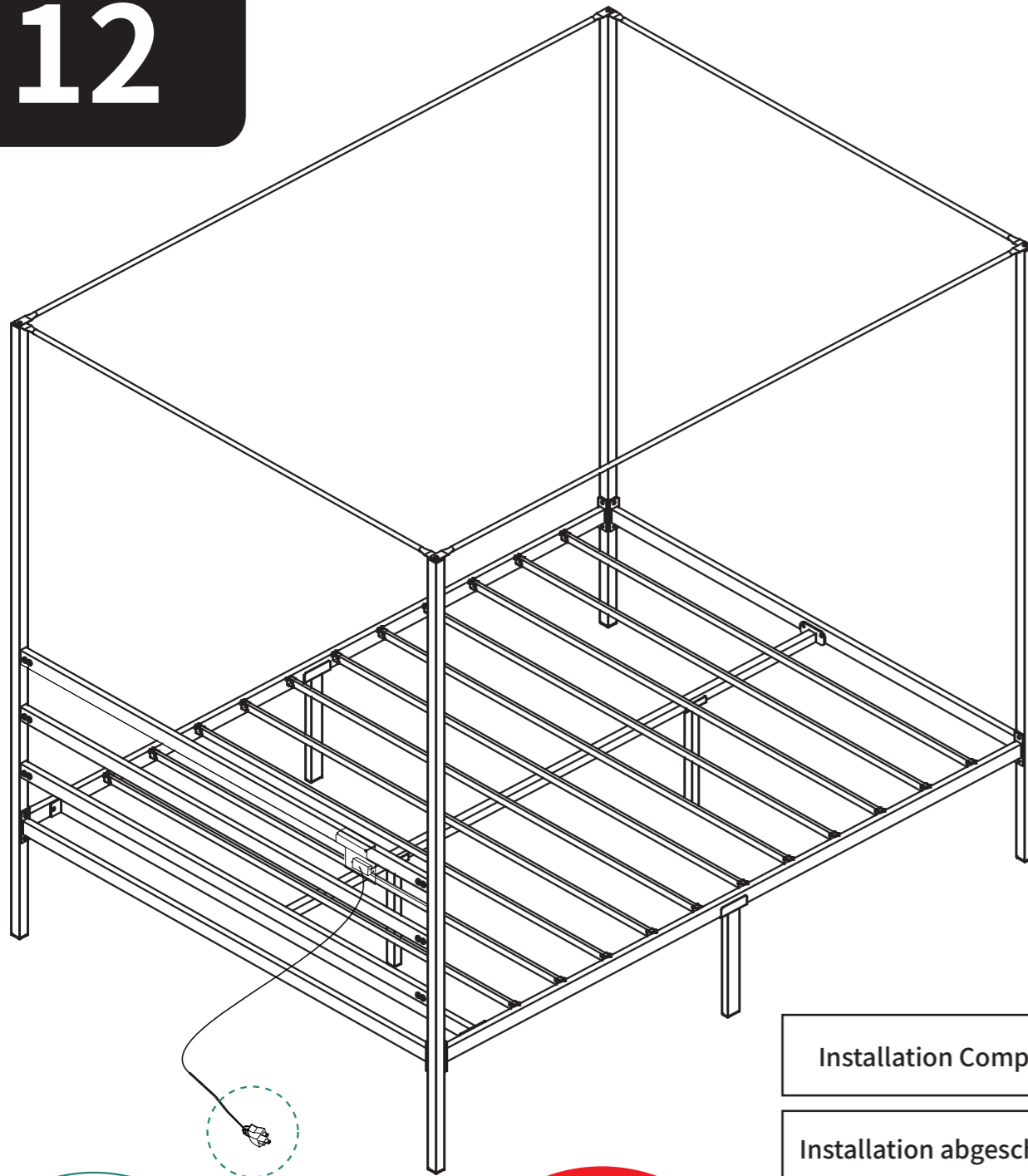

Installation Completed

Installation abgeschlossen

Installation complétée

Installazione completata

Instalación completada

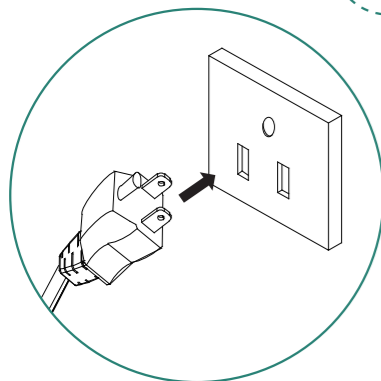

15