

# ASSEMBLY INSTRUCTION

Thank you for purchasing this quality product. Be sure to check all packing material carefully for small parts which may have come loose inside the carton during shipment. Separate, identify and count all parts and hardware. Compare with the parts list to be sure all parts are present.

**IMPORTANT : PLEASE READ INSTRUCTION BEFORE STARTING THE ASSEMBLY.**

**"DO NOT TIGHTEN SCREWS UNTIL COMPLETELY ASSEMBLED"**

**"DO NOT OVERTIGHT ANY HARDWARE"**

**WARNING : SMALL PARTS AND HARDWARE NOT FOR CHILDREN UNDER 3 YEARS. ADULT ASSEMBLY REQUIRED.**

## TABLE OF CONTENTS

HARDWARES LIST	PAGE 2
PARTS LIST	PAGE 3 - 4
PARTS' LOCATION	PAGE 5
ASSEMBLY STEPS	PAGE 6 - 10
ASSEMBLY COMPLETED	PAGE 10

## ASSEMBLY TOOLS REQUIRED

### 1. Screwdriver (not provide)



### 2. Hammer (not provide)









Skip the power trip this time.

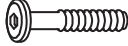
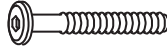

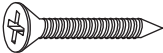
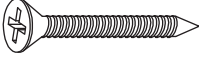

# ASSEMBLY INSTRUCTION

## HARDWARES LIST

ITEM	DESCRIPTION	DRAWING	QTY
A	JCBB SCREW M8 x 20MM		16 PCS
B	JCBC SCREW M6 x 35MM		4 PCS
C	JCBC SCREW M6 x 50MM		16 PCS
D	SPRING WASHER M6 x 13MM		16 PCS
E	FLAT WASHER M6 x 19MM		4 PCS
F	FLAT WASHER M6 x 13MM		12 PCS
G	CSK C/B SCREW (M4 x 16MM)		24 PCS
H	CSK C/B SCREW (M4 x 32MM)		16 PCS
I	M4 ALLEN KEY (100MM)		1 PC
J	M5 ALLEN KEY (65MM)		1 PC

# ASSEMBLY INSTRUCTION

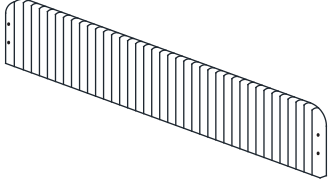
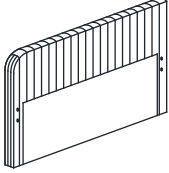
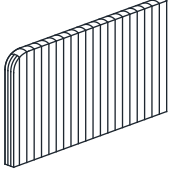
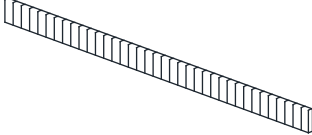
## PARTS LIST

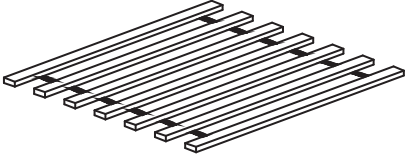
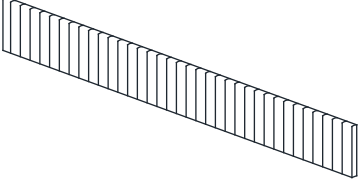
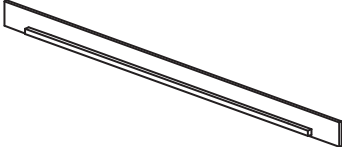
ITEM	DESCRIPTION	DRAWING	QTY
1	BACK PANEL		1 PC
2	SIDE PANEL (L)		1 PC
3	SIDE PANEL (R)		1 PC
4	FRONT SIDE RAIL		1 PC
5	BACK SIDE RAIL		1 PC
6	LEG		4 PCS
7	DAYBED SLAT		2 ROLL
8	TRUNDLE FRONT RAIL		1 PC
9	TRUNDLE BACK RAIL		1 PC

MORE PARTS DETAIL IN NEXT PAGE...

# ASSEMBLY INSTRUCTION

## PARTS LIST

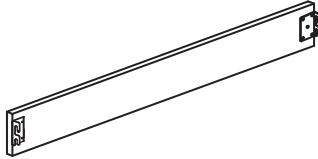
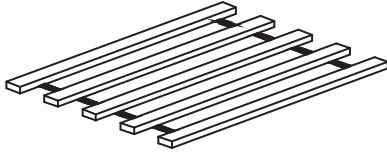
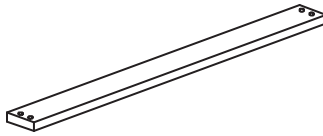
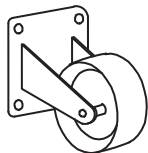
ITEM	DESCRIPTION	DRAWING	QTY
10	TRUNDLE SIDE RAIL		2 PCS
11	TRUNDLE SLAT		2 ROLL
12	SLAT SUPPORT		3 PCS
13	CASTOR		6 PCS

# ASSEMBLY INSTRUCTION

## PARTS ' LOCATION

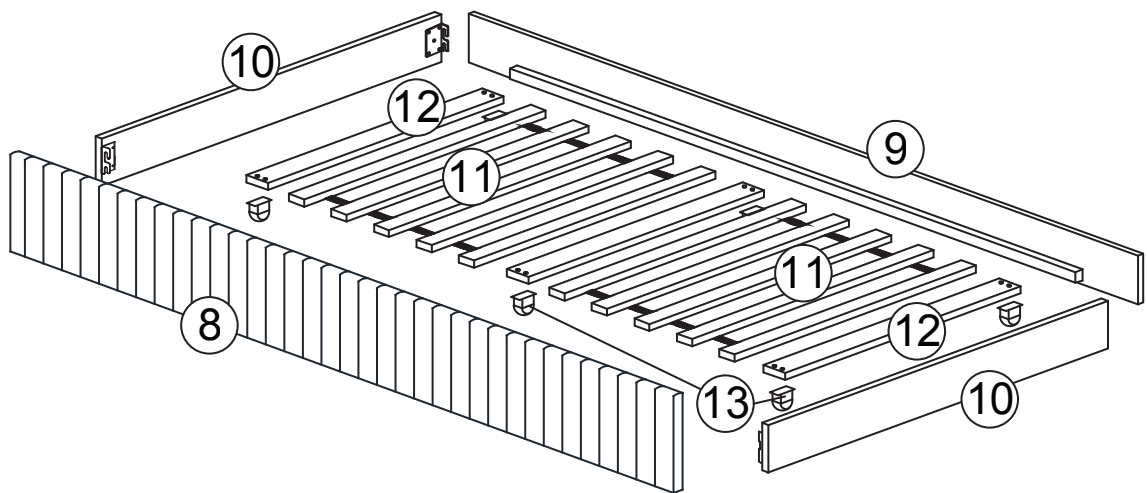
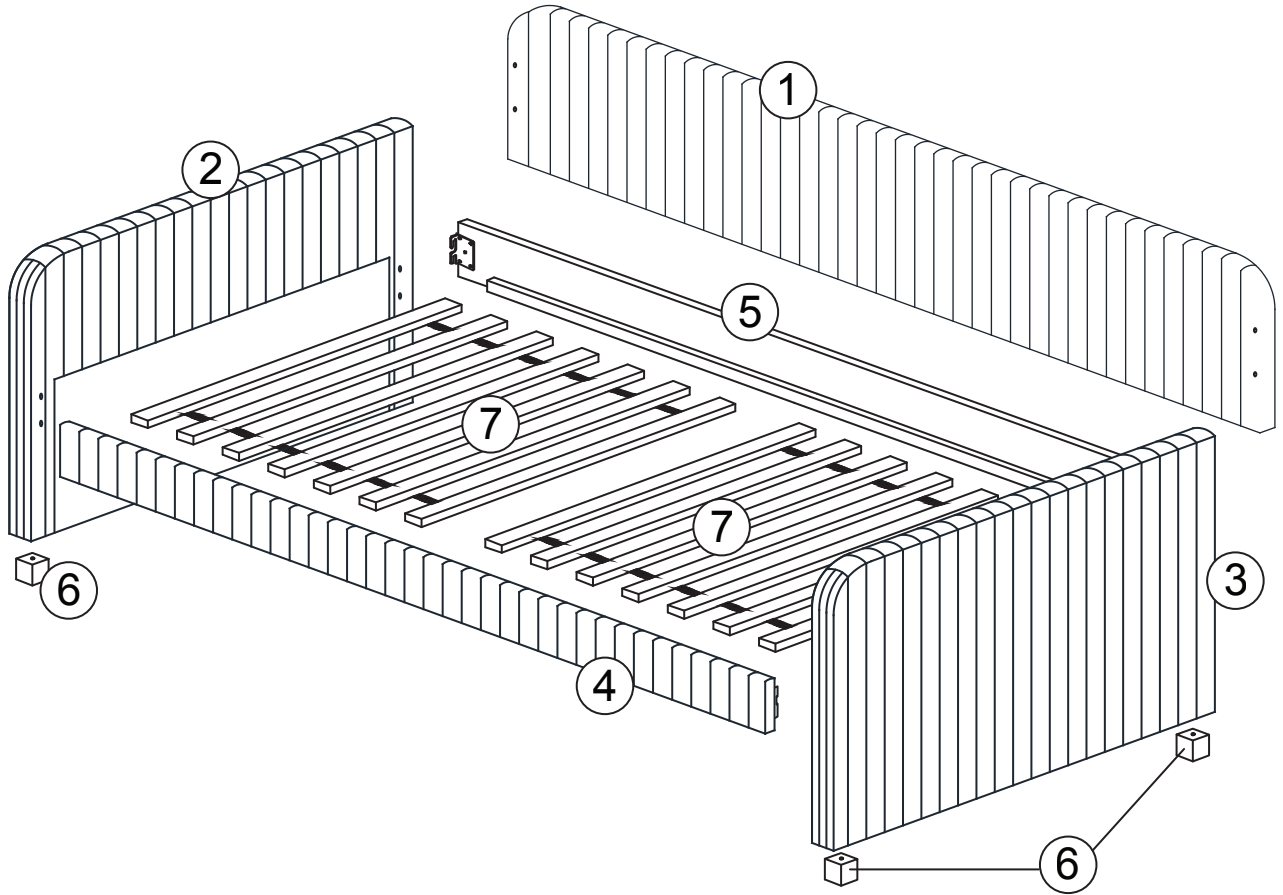

# ASSEMBLY INSTRUCTION

## STEP 1

Insert 4pcs (B) to combine 4pcs (6) to (2) and (3) as shown.

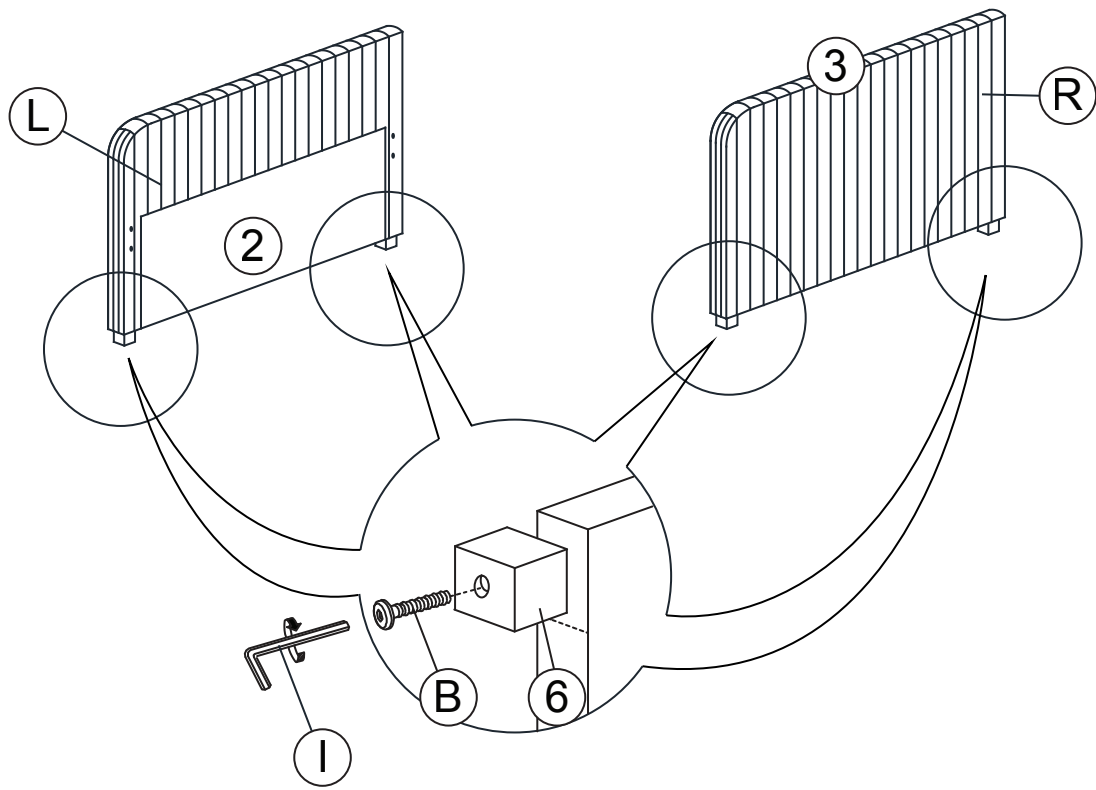

## STEP 2

Insert 8pcs (A) to combine (4) and (5) to (2) and (3) as shown.

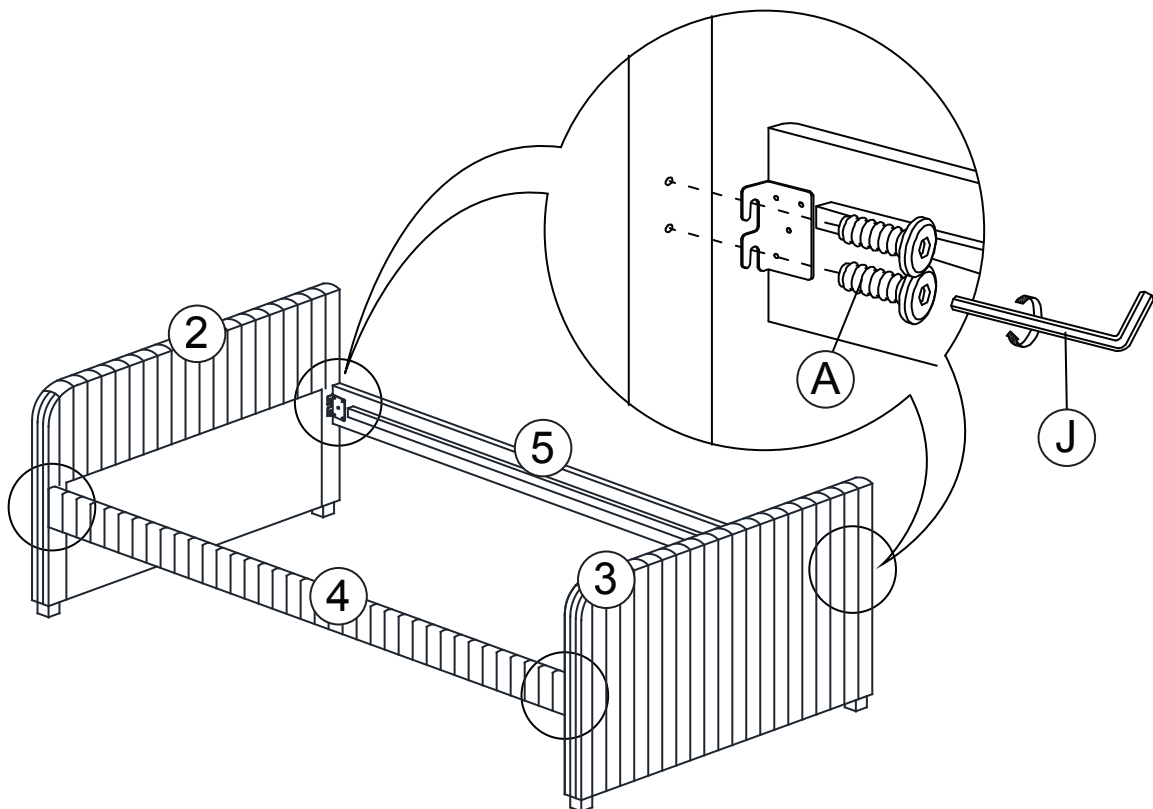

# ASSEMBLY INSTRUCTION

## STEP 3

Insert 4pcs (C) , (D) and (E) to combine (1) to (2) and (3) as shown.

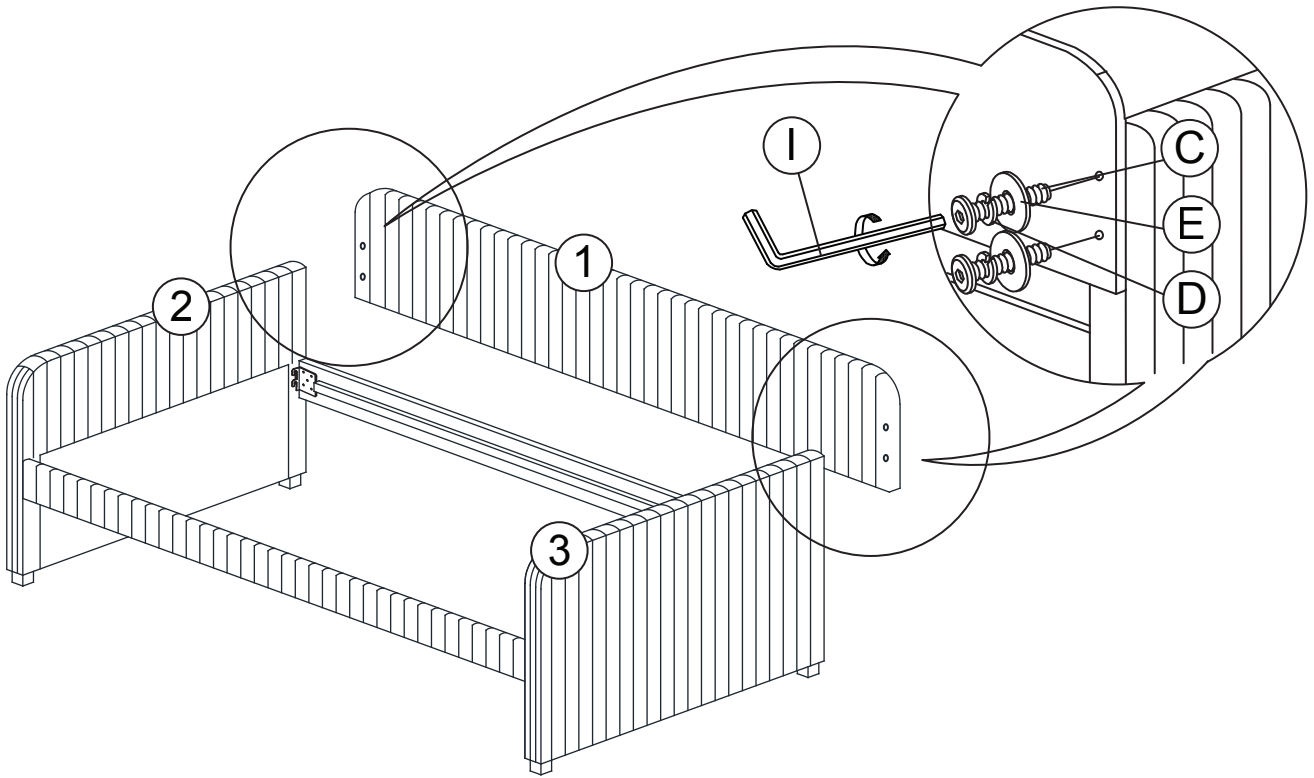

## STEP 4

Put the slat to the inside of daybed , then insert 8pcs (H) to tighten the slat.

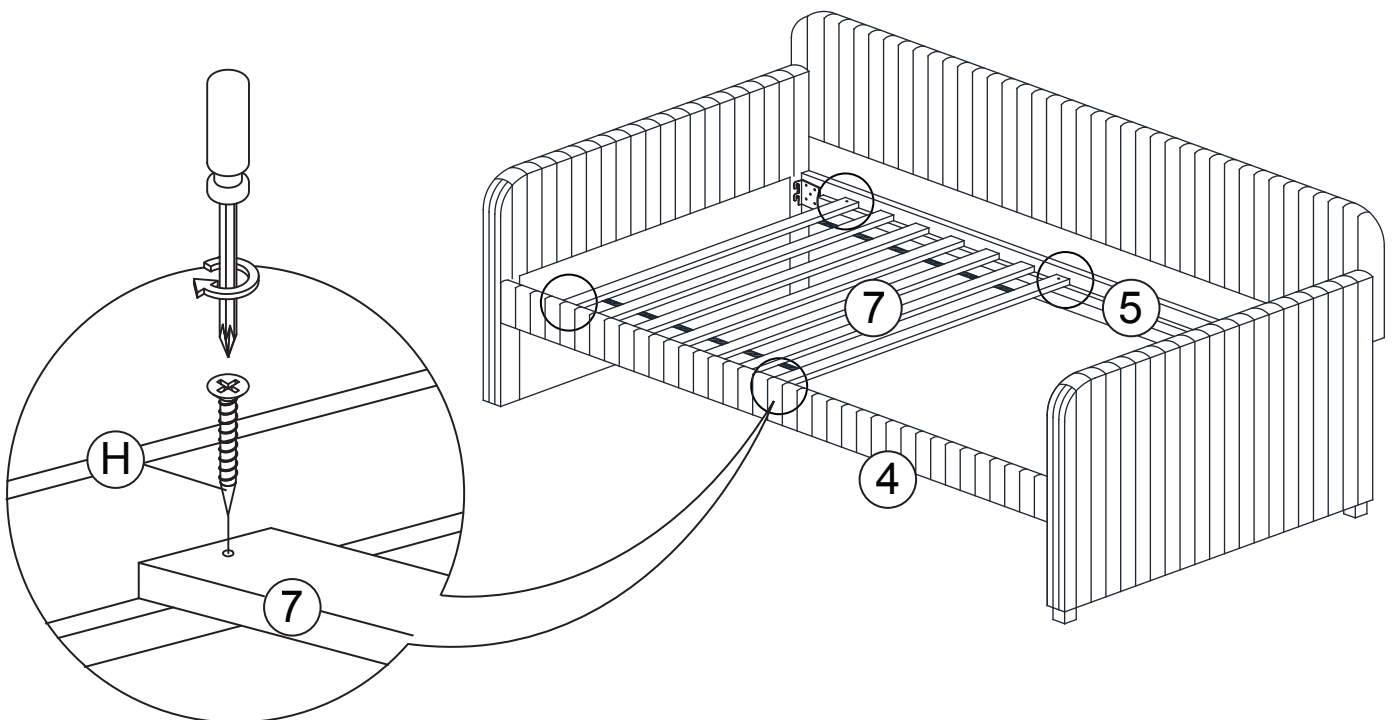

# ASSEMBLY INSTRUCTION

## STEP 5

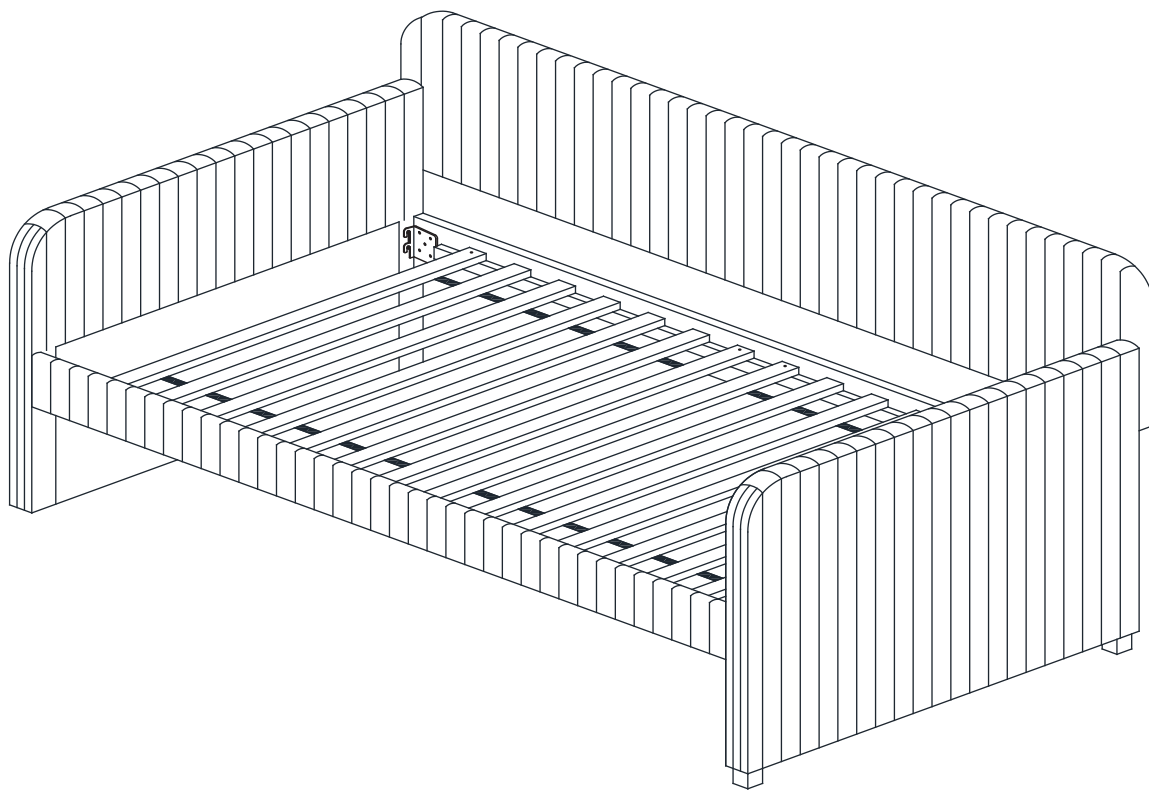

## STEP 6

Insert 8pcs (A) to combine (10) to (8) and (9) as shown.

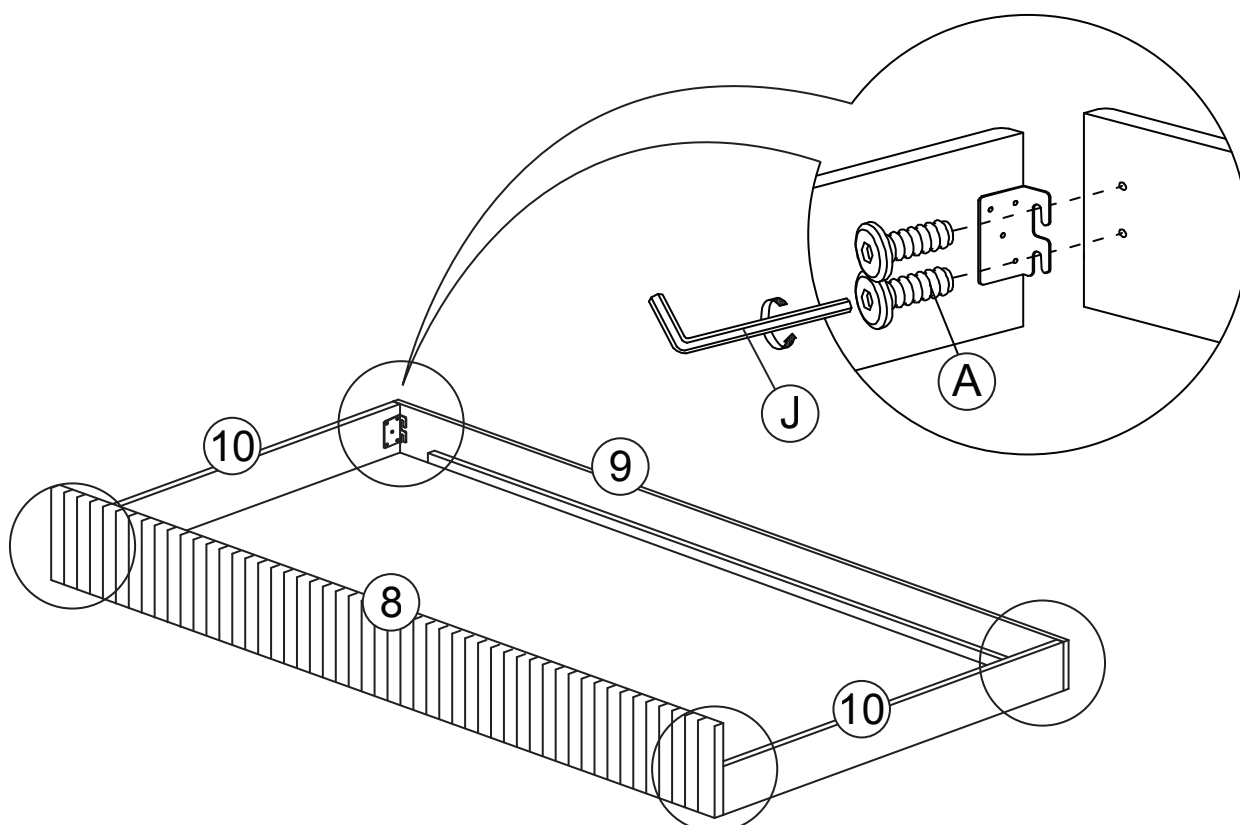

# ASSEMBLY INSTRUCTION

## STEP 7

Insert 24pcs (G) to combine 6pcs (13) to (12) as shown.

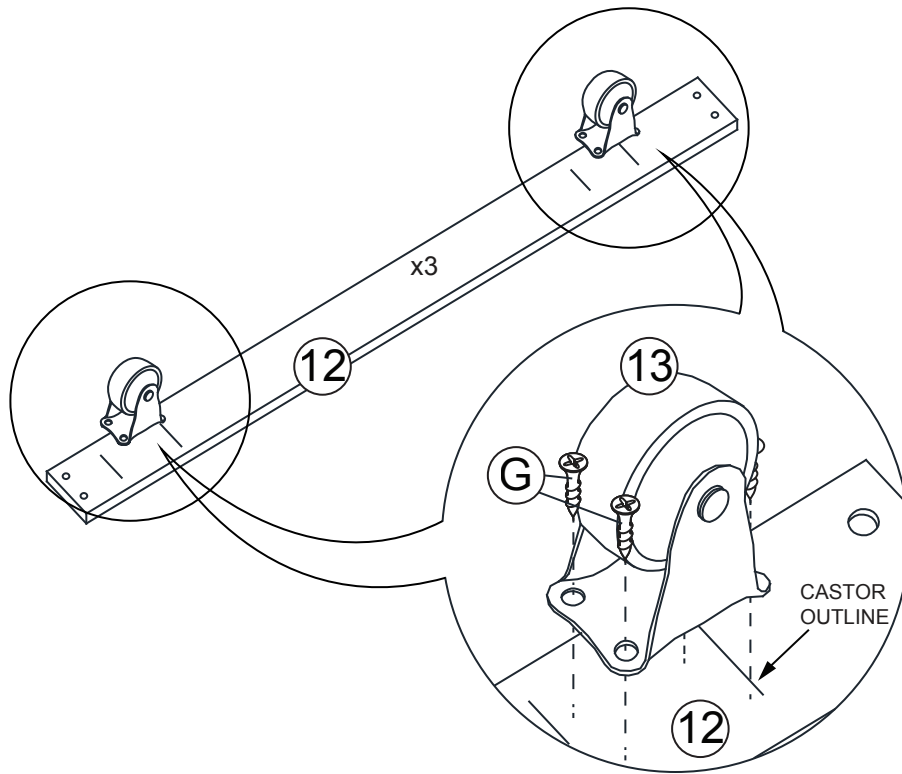

## STEP 8

Insert 12pcs (C) , (D) and (F) to combine 3pcs (12) to (8) and (9) as shown.

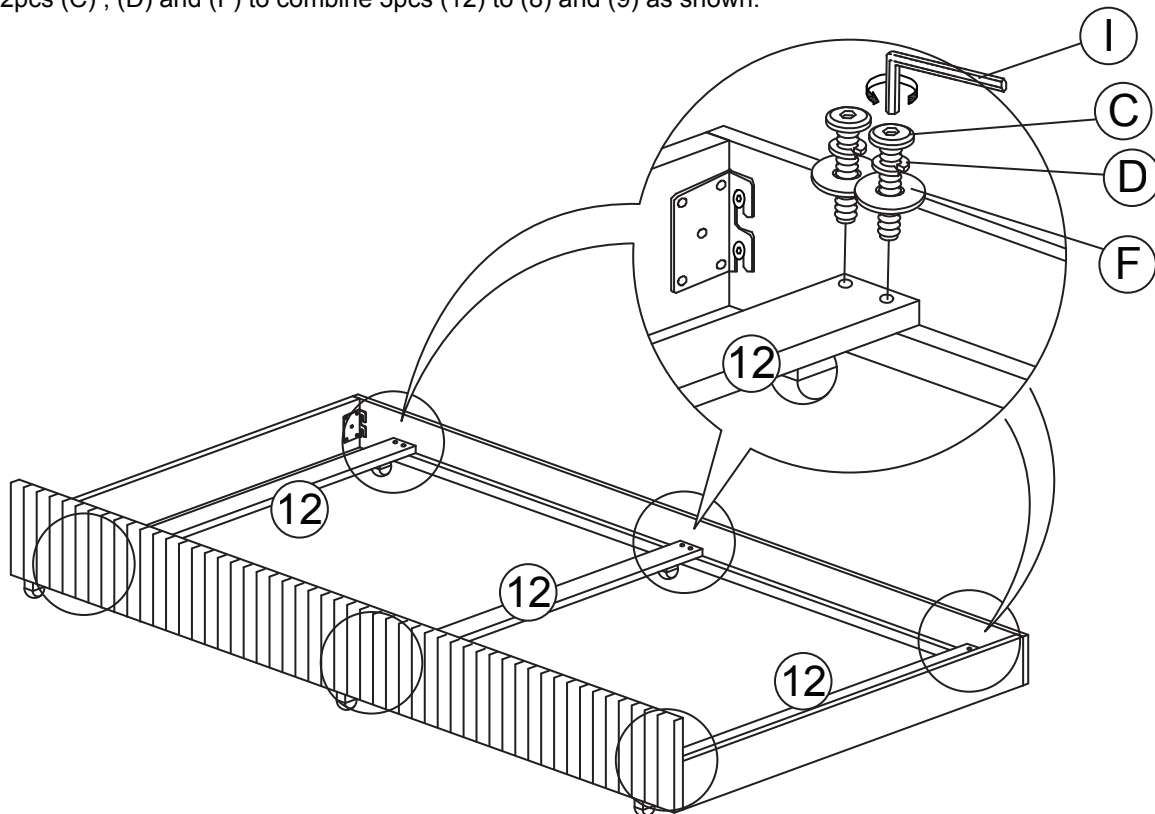

# ASSEMBLY INSTRUCTION

## STEP 9

Put the slat to the inside of trundle , then insert 8pcs (H) to tighten the slat.

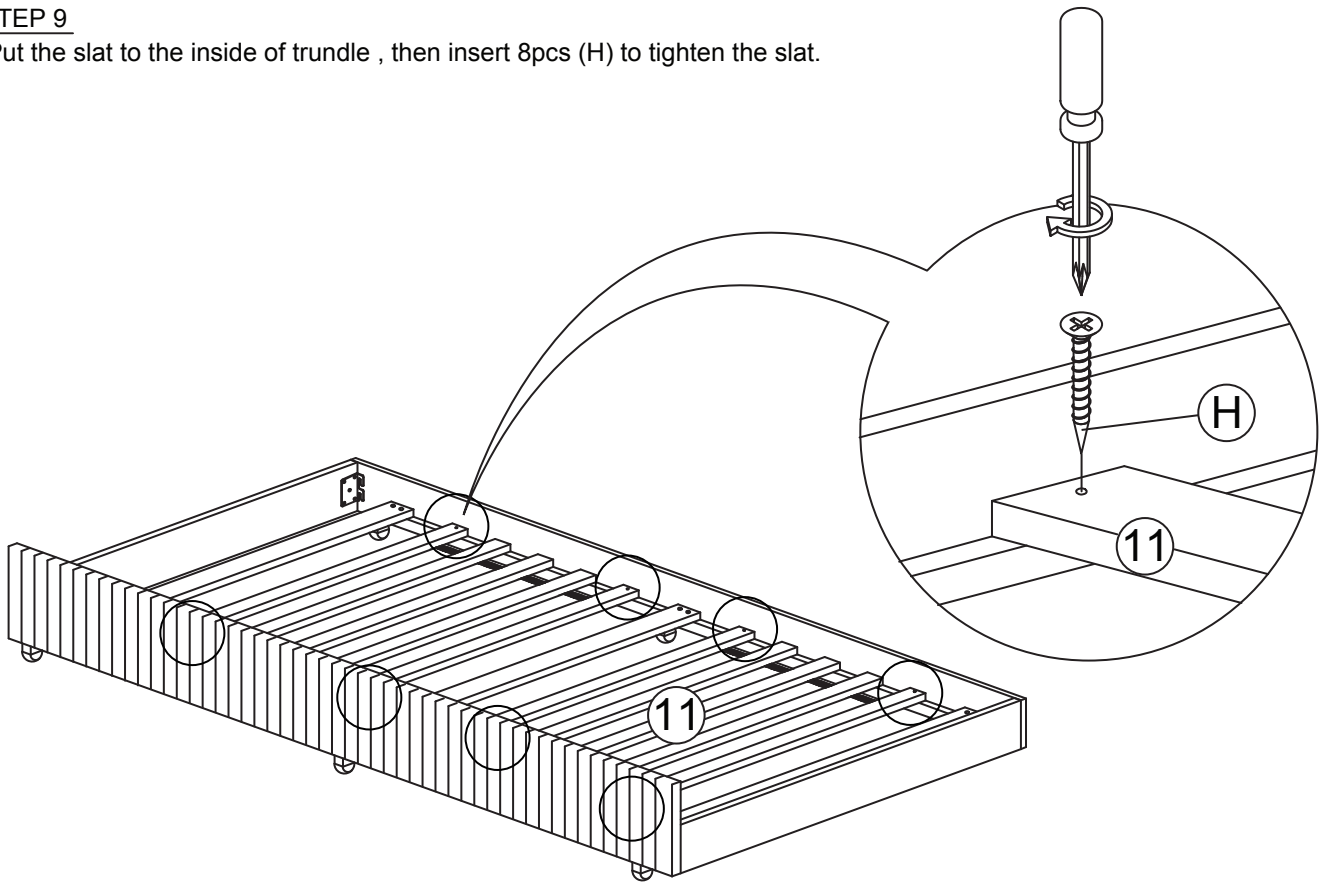

## STEP 10

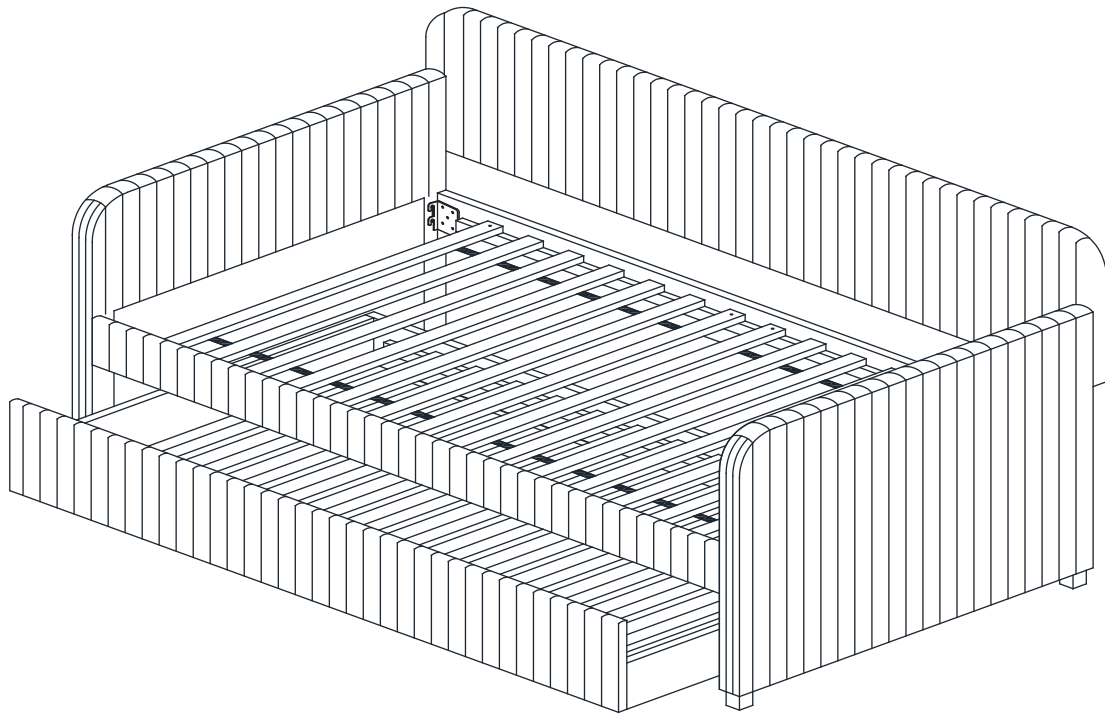

**ASSEMBLY COMPLETED**