

Installation Instruction

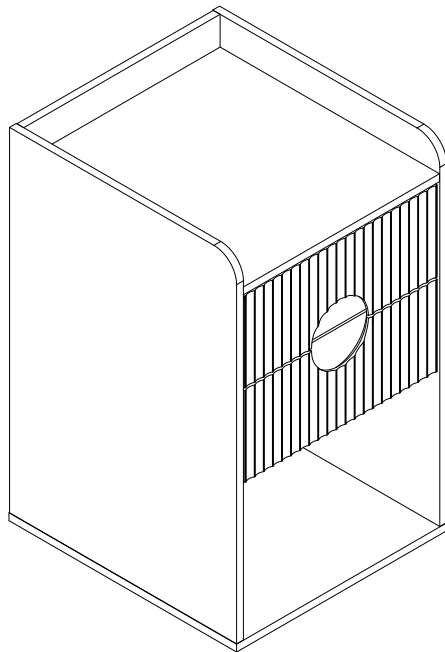

Assembling

What you need

- Use the packaging carton as a working surface to prevent product damage during assembly
- Phillips head screwdriver

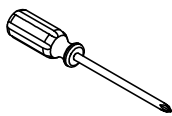

Weight Limitation



100 | **35**
lbs table top | lbs per

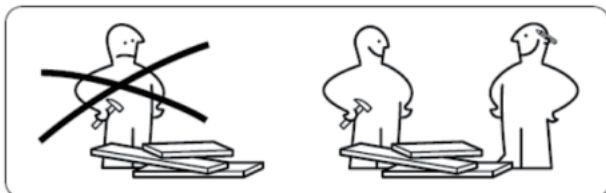

What' included

Code	Description	Qty
A	Cam Bolt M6X35MM	18
B	Cam Lock 15X9MM	18
C	Wooden Dowel M6X30MM	14
D	Screw M4X40MM	16
E	Screw M3.5X12MM	2
F	EVA foot mat	4
G	Circular hole Decals	18
H	Screw M3.0X12MM	24
I	Anchor	2
J	L-shaped metal sheet	2
K	The back button	8
CL	Left mother extended orbit	2
CR	Right mother extended orbit	2
DL	Left public extension track	2
DR	Right public extends track	2

The Hardwares

A

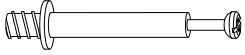

B

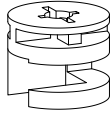

C

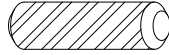

D

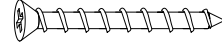

E



F

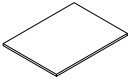

G

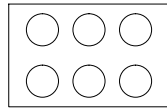

H



I

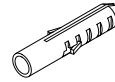

J

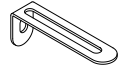

K

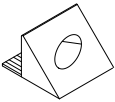

CL

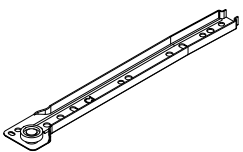

CR

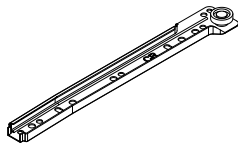

DL

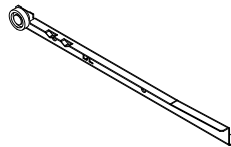

DR

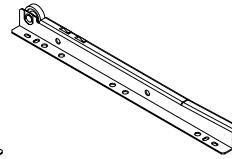

IMPORTANT:

1. Do not tighten bolts / screws completely until all bolts / screws are lined up and inserted into holes.
2. Do not over tighten screws and bolts to avoid stripping
3. Please use hand tools to assemble this product, you can also use power tools (please use power tools carefully)
4. In case of packaging damage during transportation, missing components, or the need for installation guidance, don't rush, feel free to reach out to our dedicated seller support team for professional assistance.

Included Accessories

Code	Description	Qty
1	Cabinet Top	1
2	Bottom Panel	1
3	Left Side Panel	1
4	Right Side Panel	1
5	Backboard	1
6	Drawer left side panel	2
7	Drawer right side panel	2
8	The drawer bottom	2
9	After the drawer board	2
10	Drawer panel	1
11	Drawer panel	1
12	Baffle	1
13	Back connection plate	1
14	Front connecting plate	1

The Accessoriess

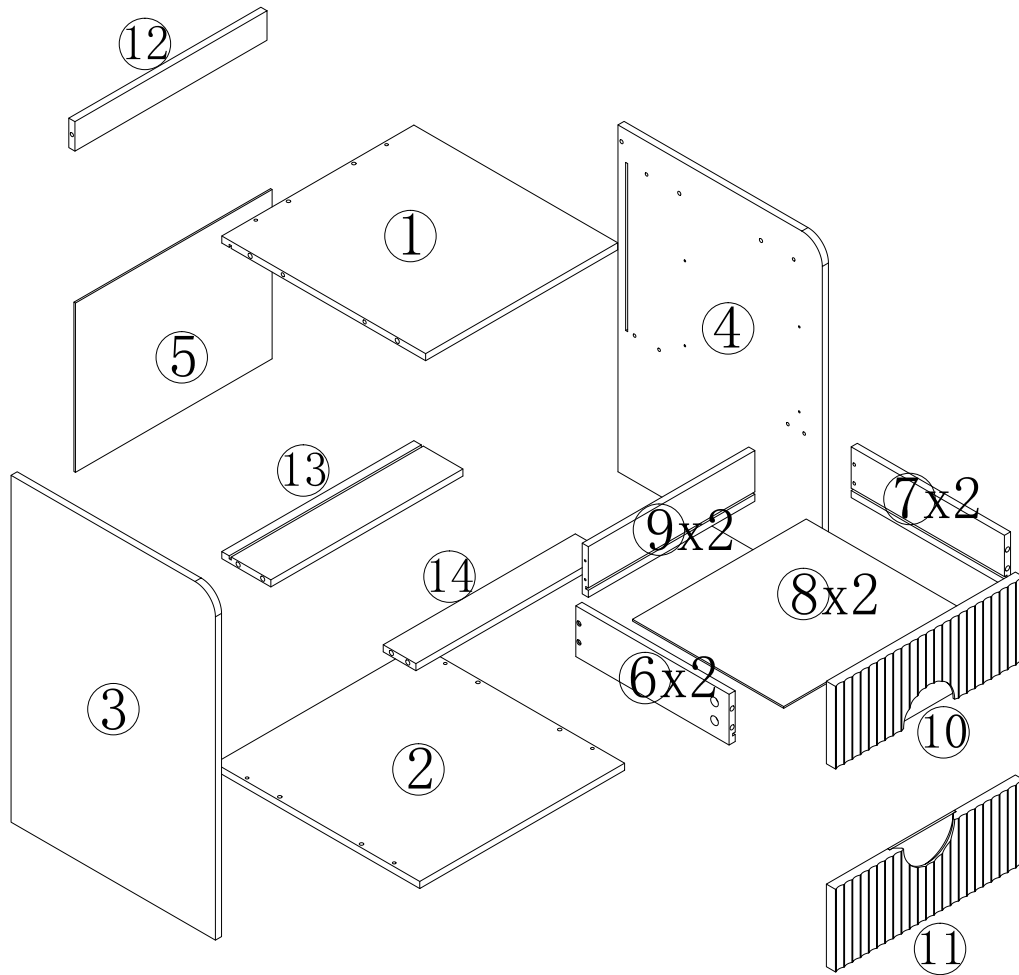

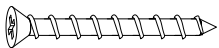

Step 1

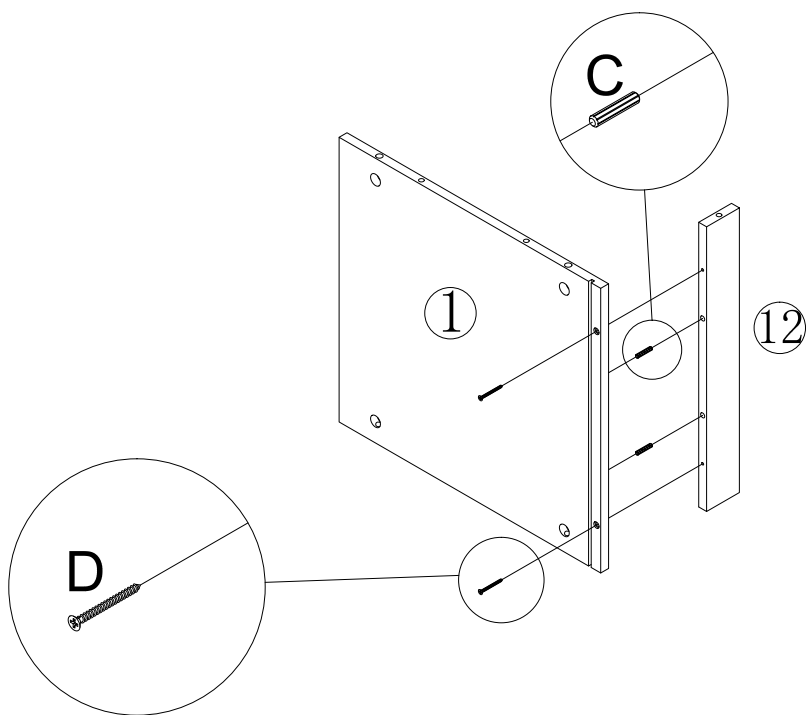
C	x 2	D	x 2
			



Step 2

CL	x 2	CR	x 2	H	x 8
					

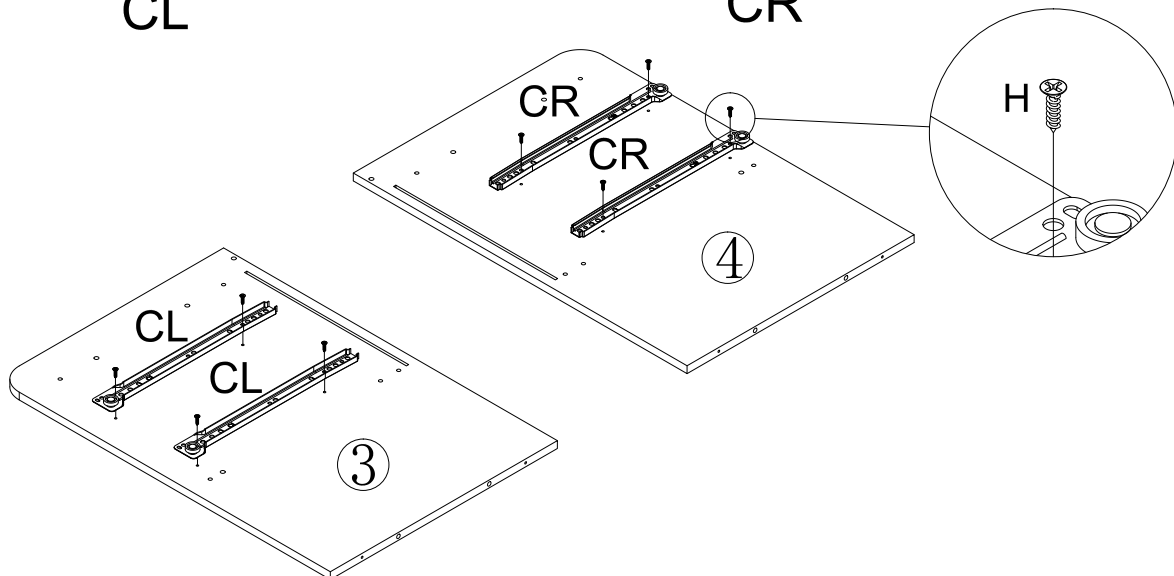
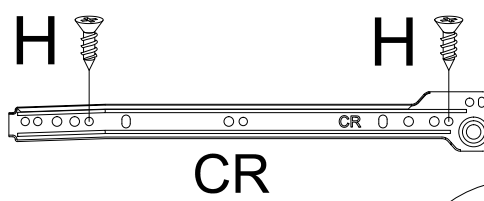
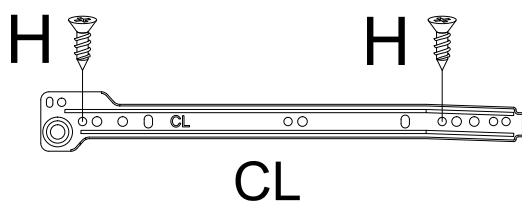

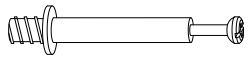

Step 3

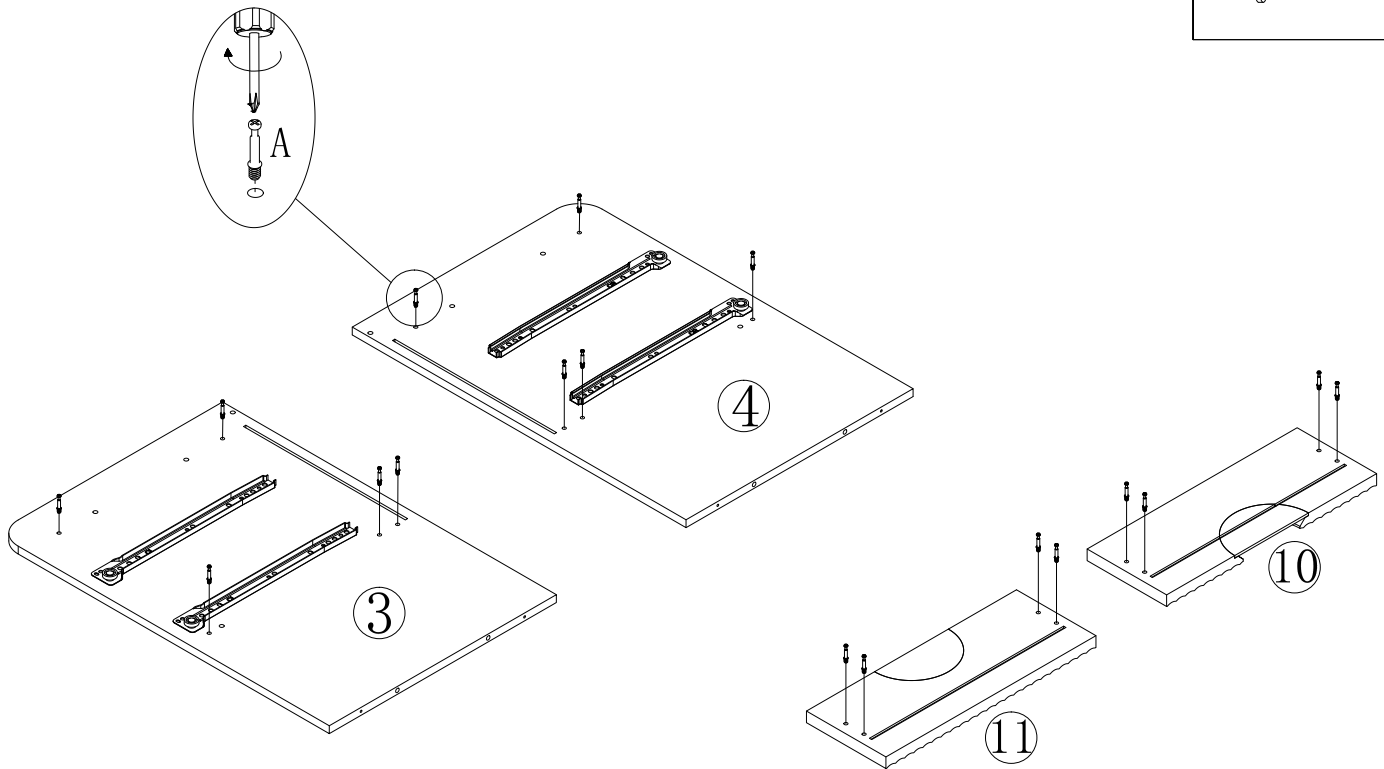
A	x 18
	

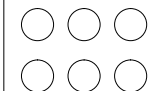

Step 4

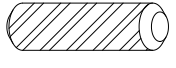
G	x 5	B	x 5	C	x 4
					

Pay attention to aligning the card slots during installation.

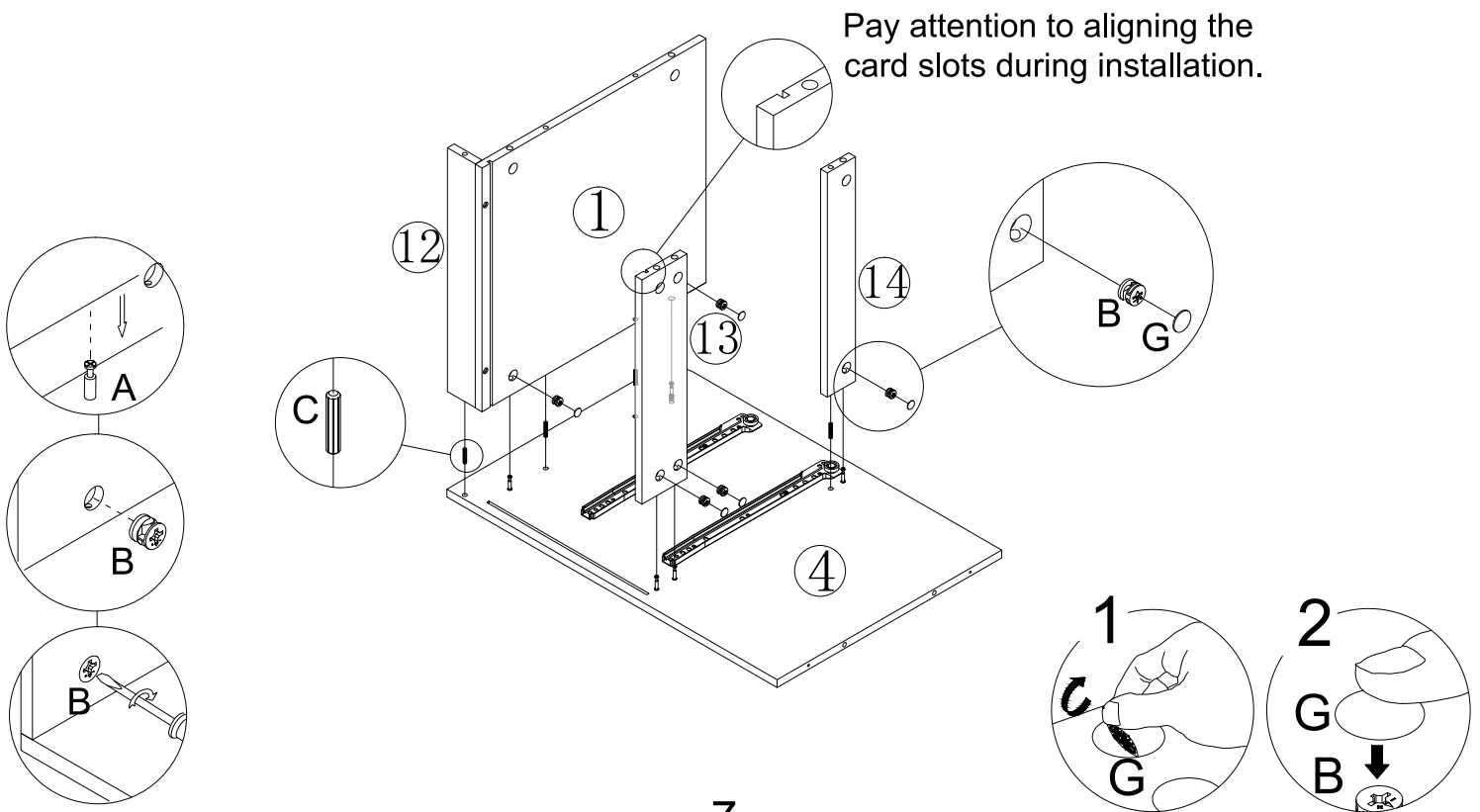

Step 5

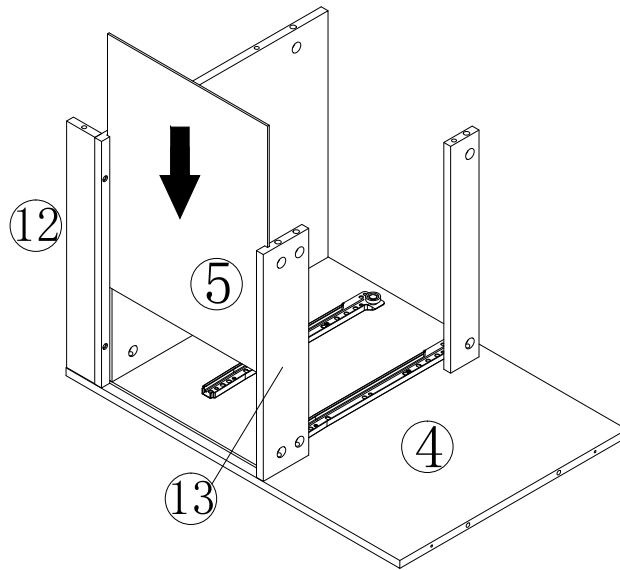

Step 6

G	x 5	B	x 5	C	x 4

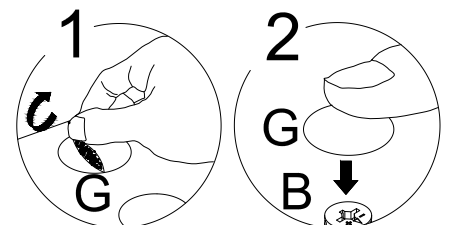
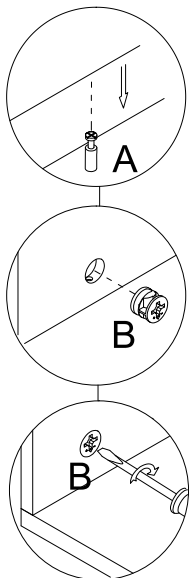
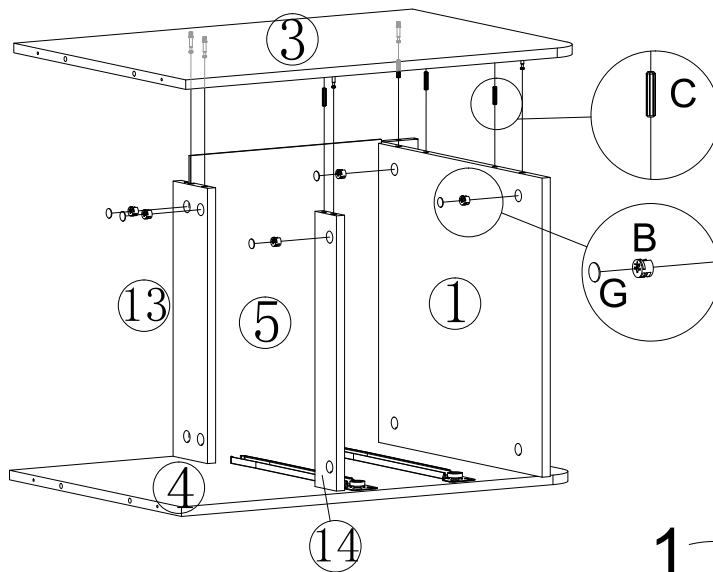

Step 7

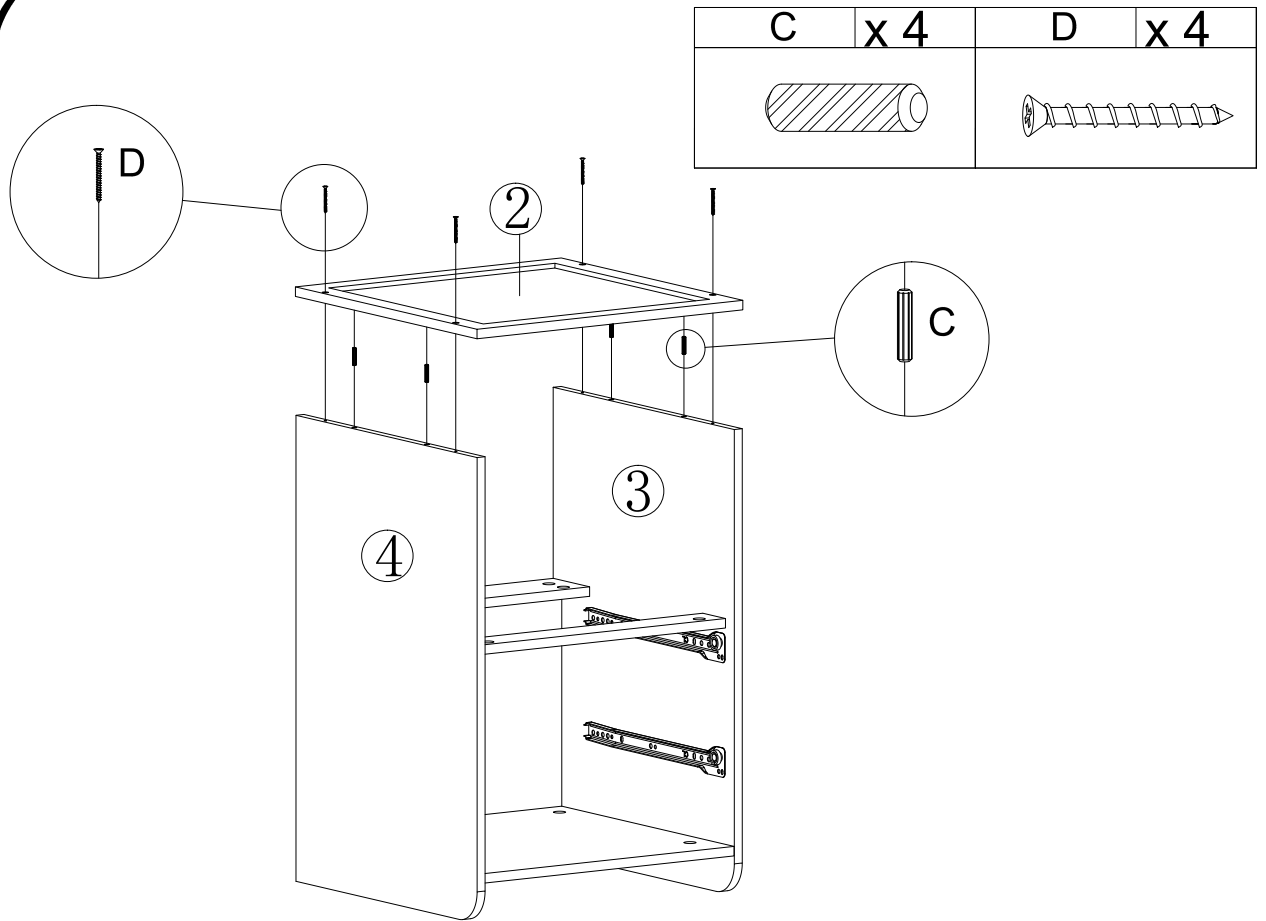

Step 8

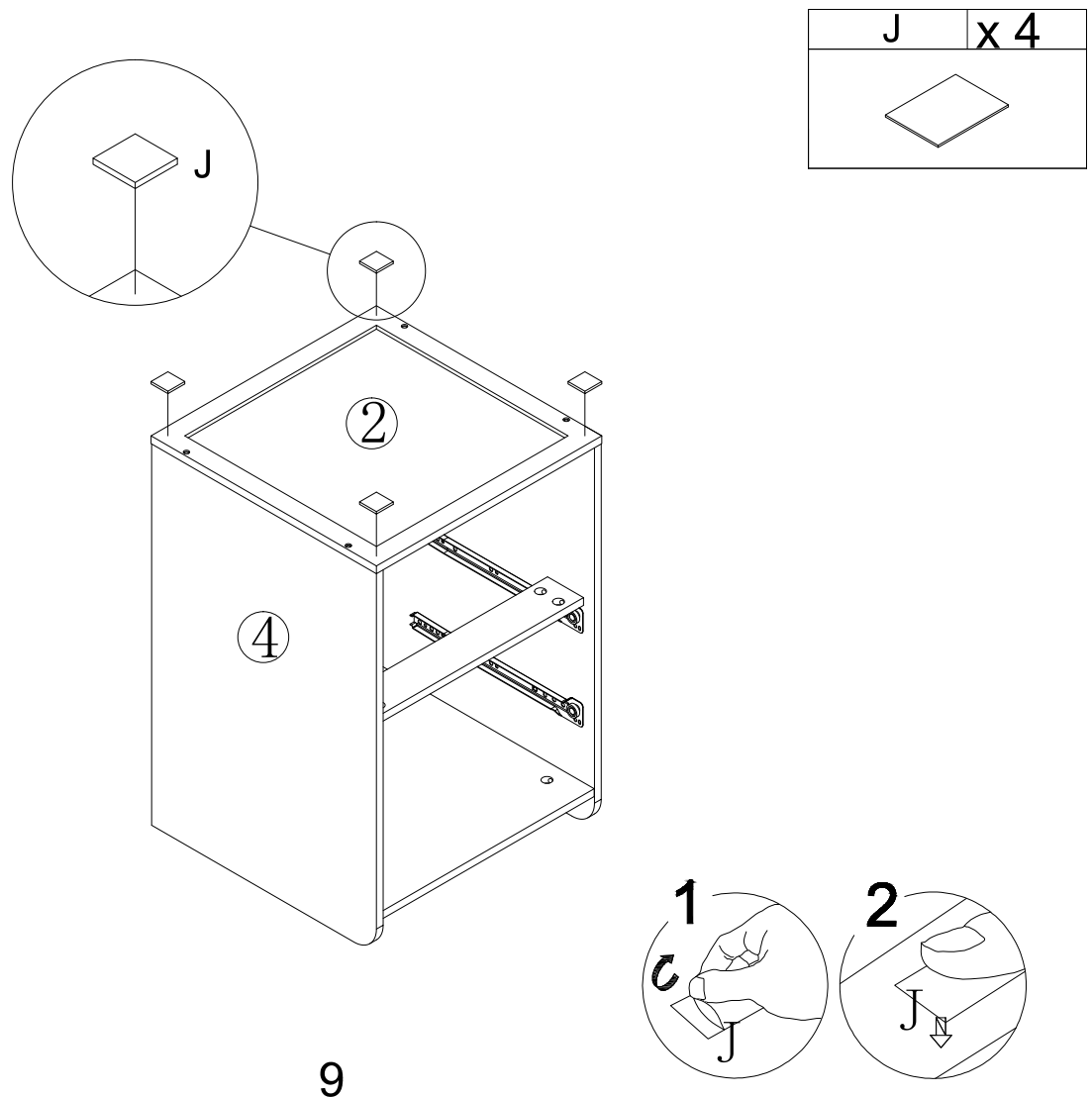

Step 9

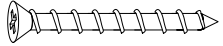
D	x 8
	

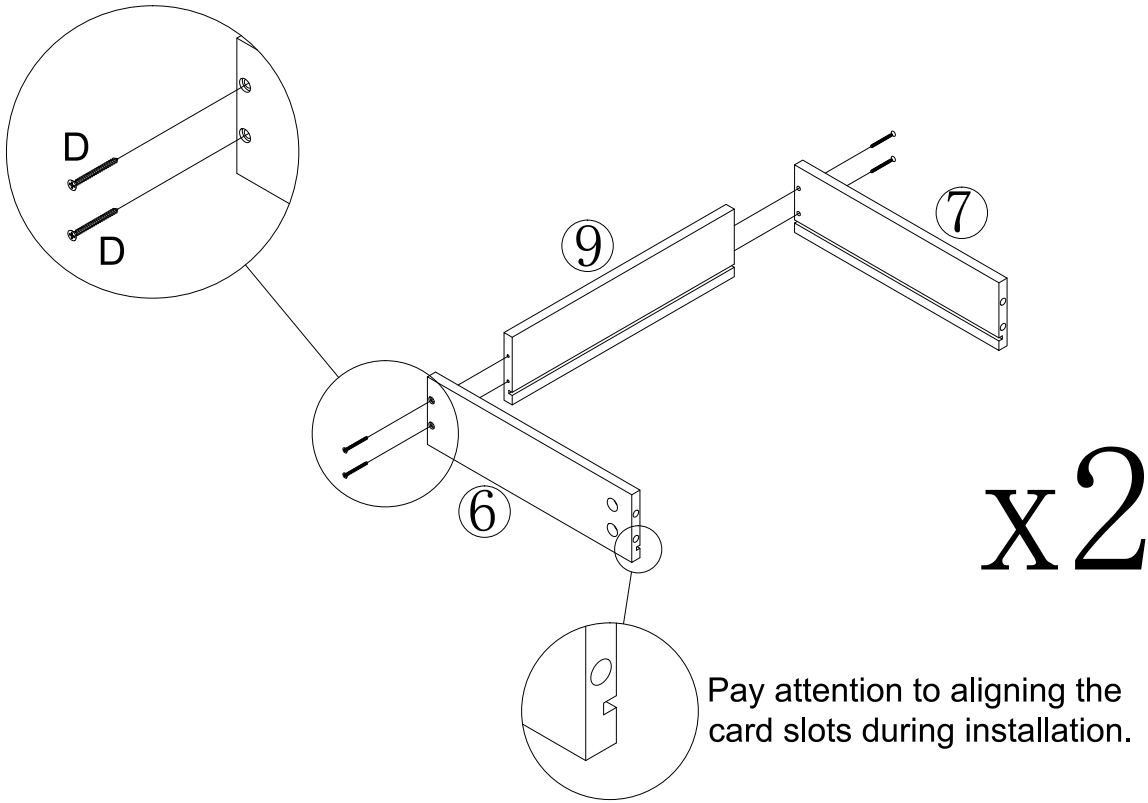

Step 10

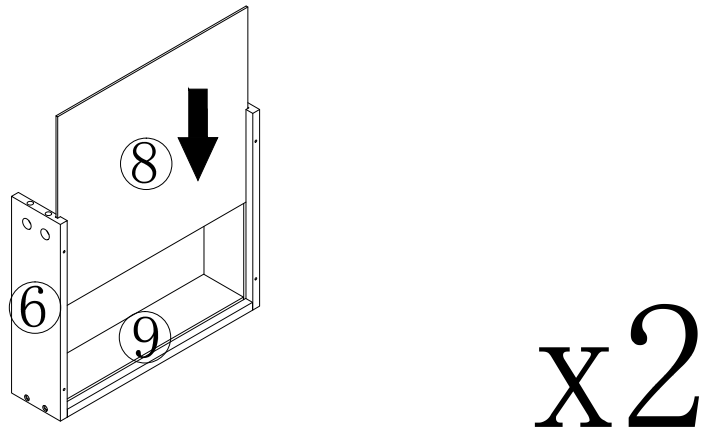

Step 11

G	x 8	B	x 8

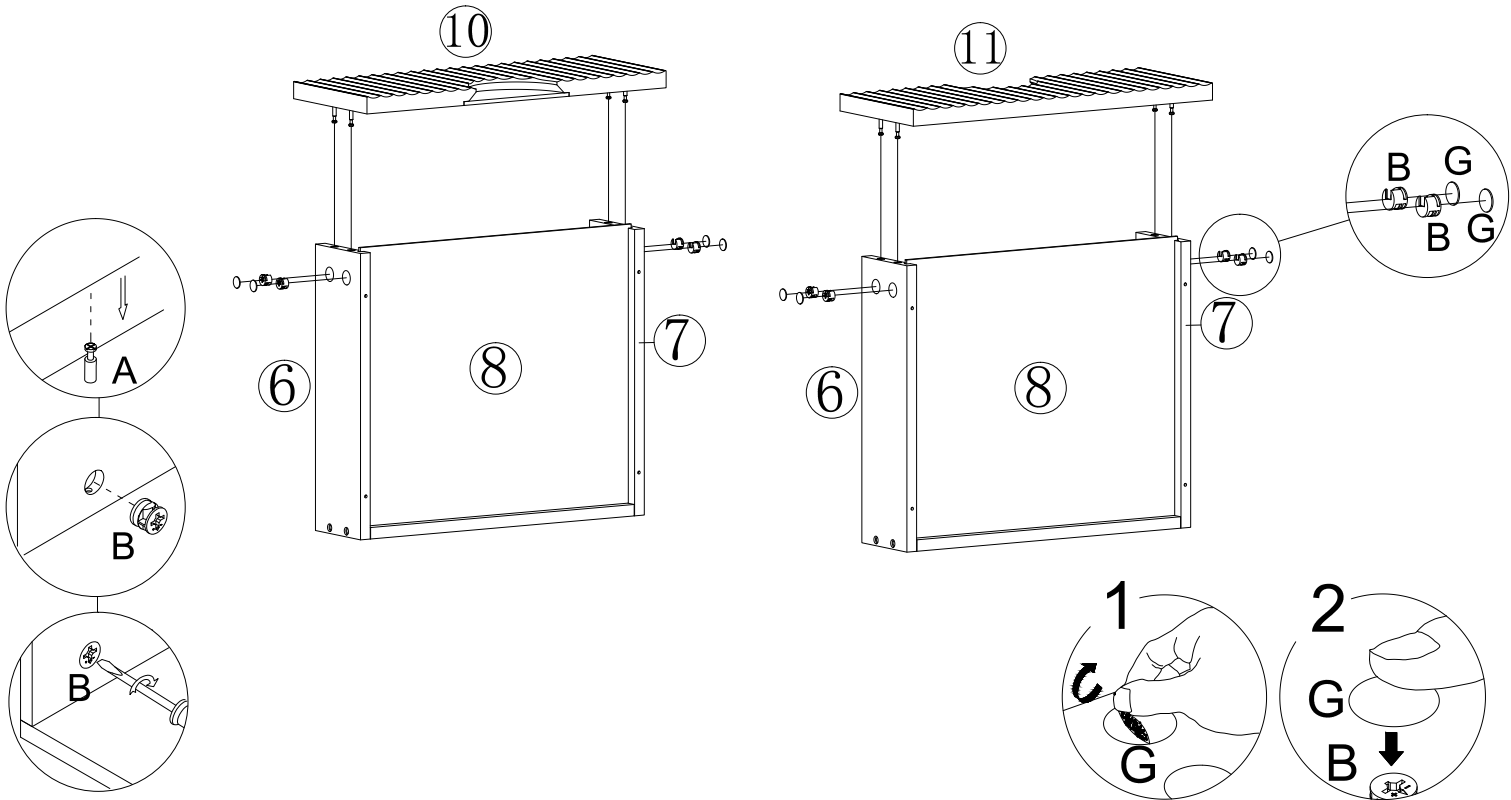

Step 12

DL	x 2	DR	x 2	H	x 8

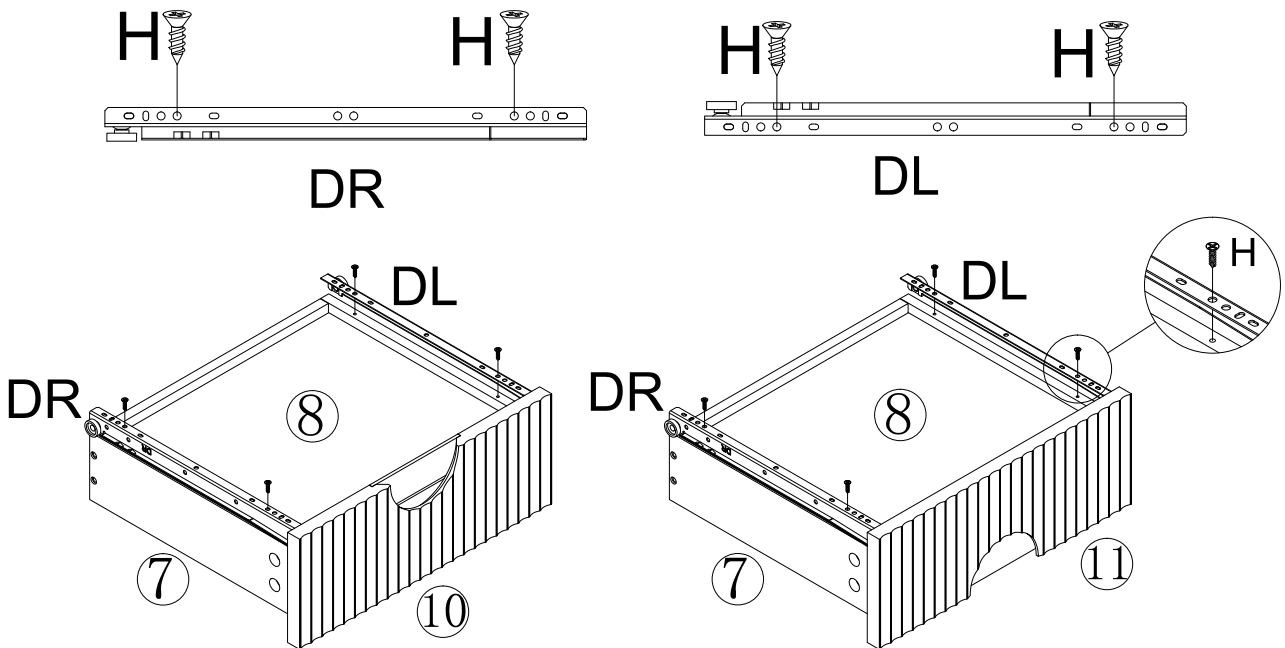

Step 13

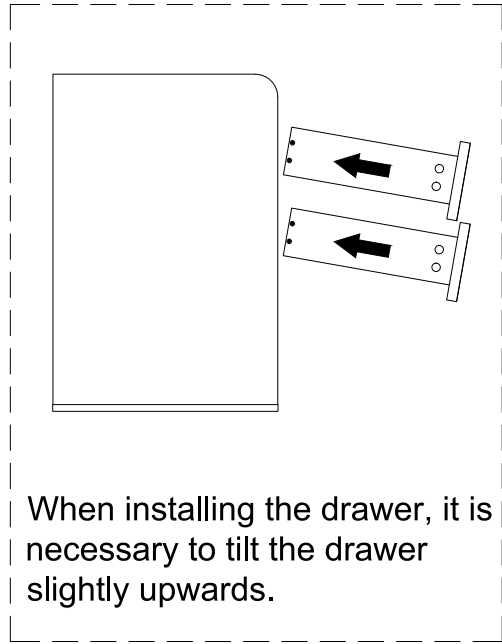
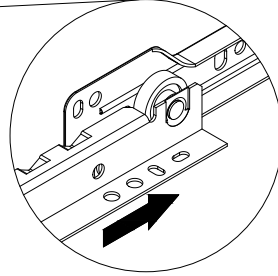
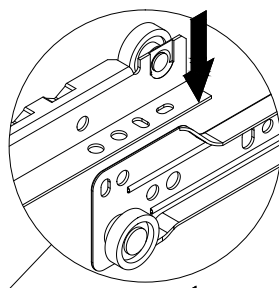
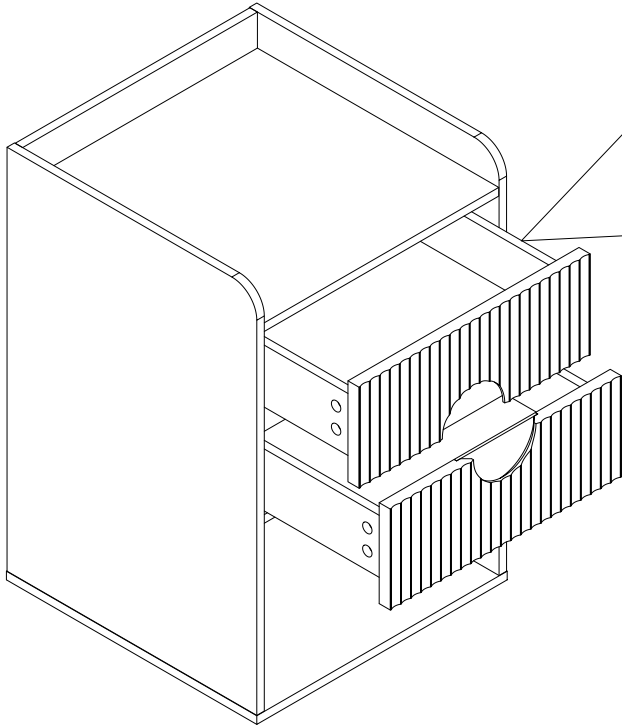

Step 14

I	x 2	H	x 8	D	x 2	K	x 8
						J	x 2

If the cabinet shakes, installing accessory I can solve the problem.

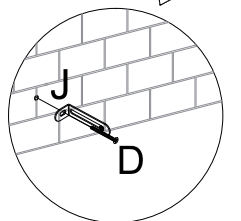
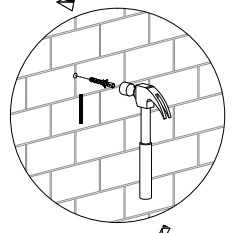
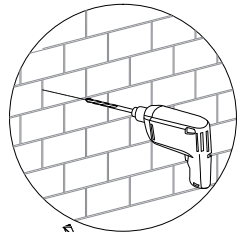
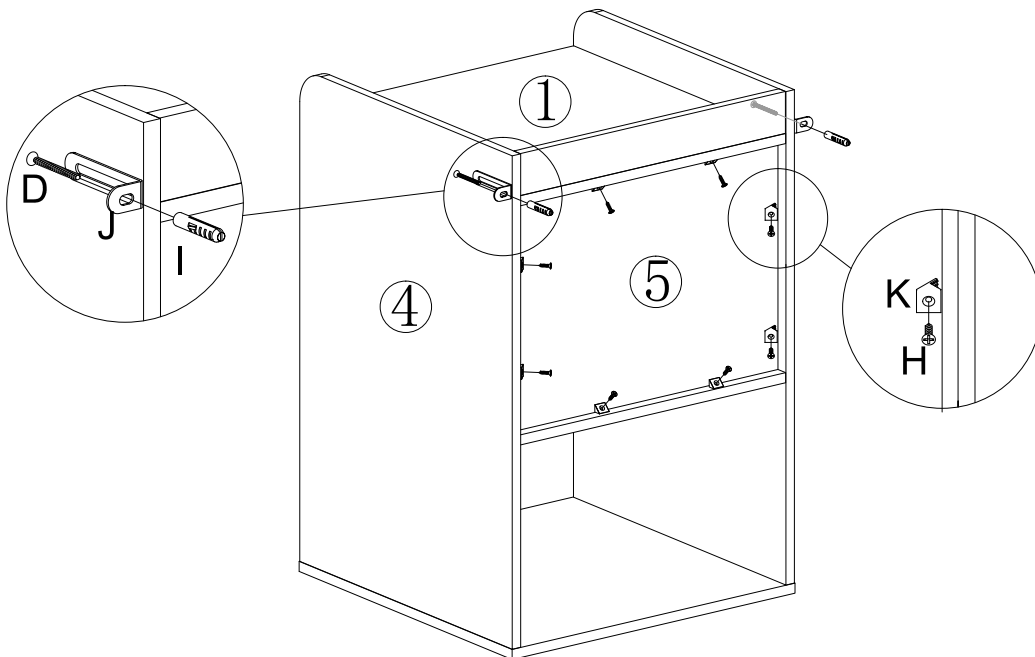

Step 15

E	x 2
