

Attention: Please don't tighten the screws completely and go back later for a final tightening of all the screws after pieces are aligned with each other. If the screws are tightened initially, subsequent hole positions may be misaligned.

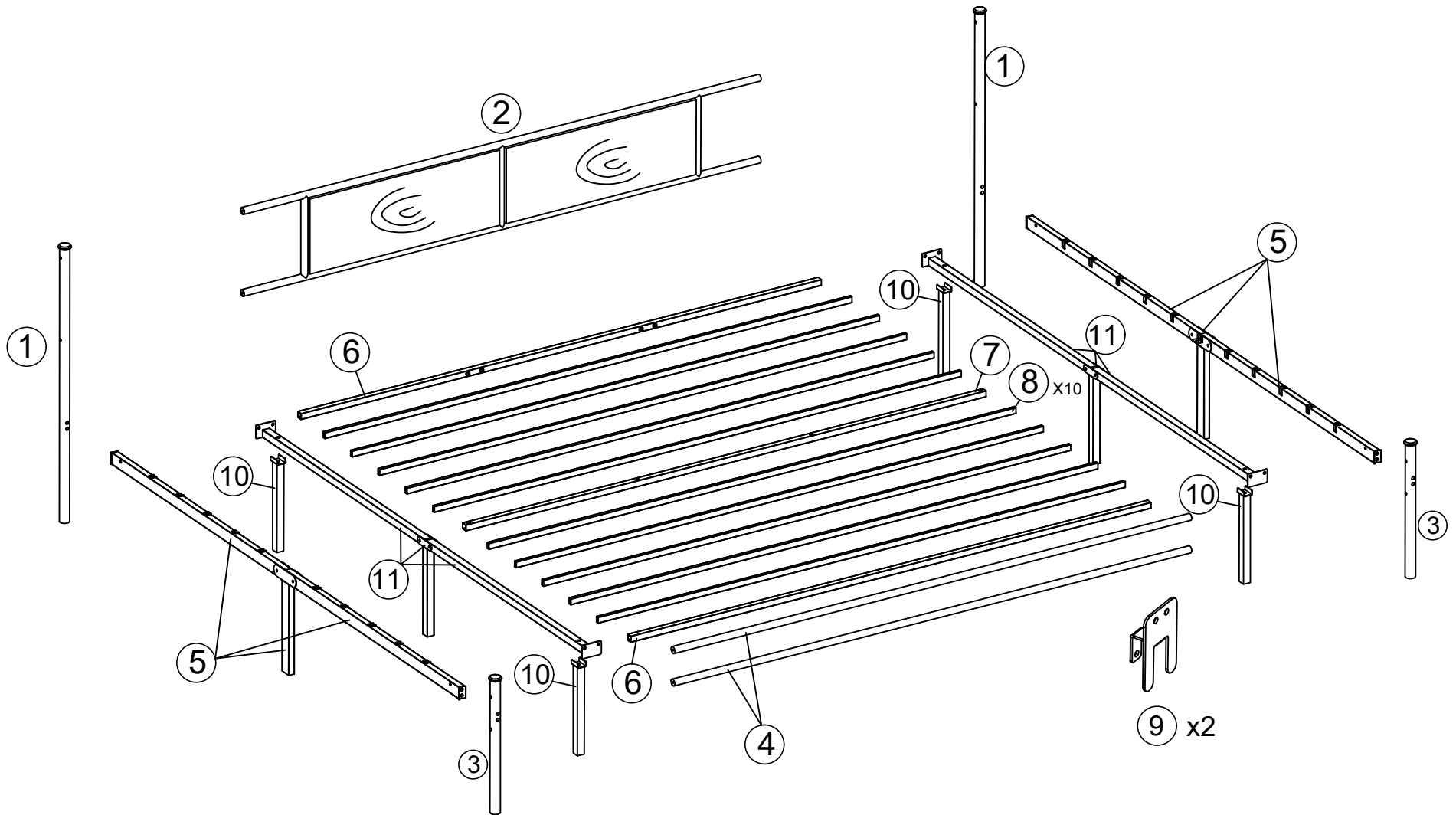

Hardware arts



M6X35
① 6PCS



M6X45
② 8PCS



M6X55
③ 2PCS



M8X15
④ 8PCS



M8X45
⑤ 12PCS



4#
⑥ 2PCS

Part list

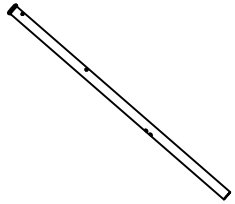

① 2PCS

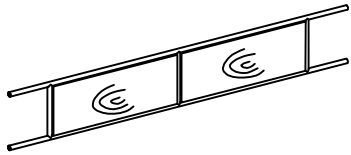

② 1PC

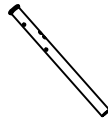

③ 2PCS

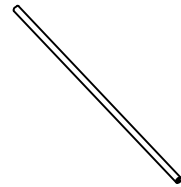

④ 2PCS

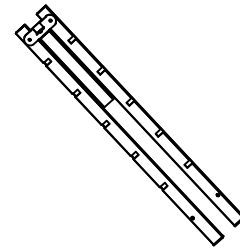

⑤ 2PCS

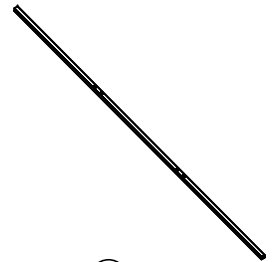

⑥ 2PCS

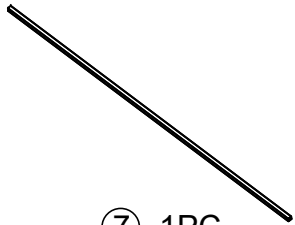

⑦ 1PC

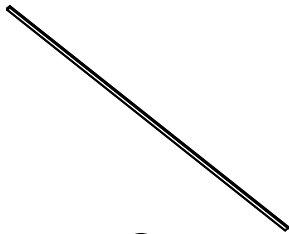

⑧ 10PCS



⑨ 2PCS



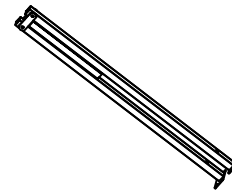

⑩ 4PCS





⑪ 2PCS

Step:1

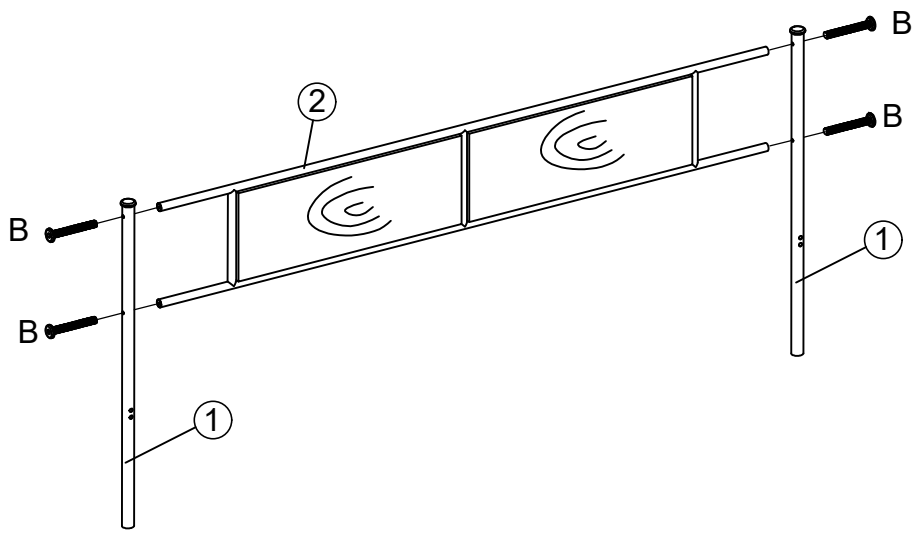
	M6X45	B	4PCS		4#	F	1PC
---	-------	---	------	--	----	---	-----



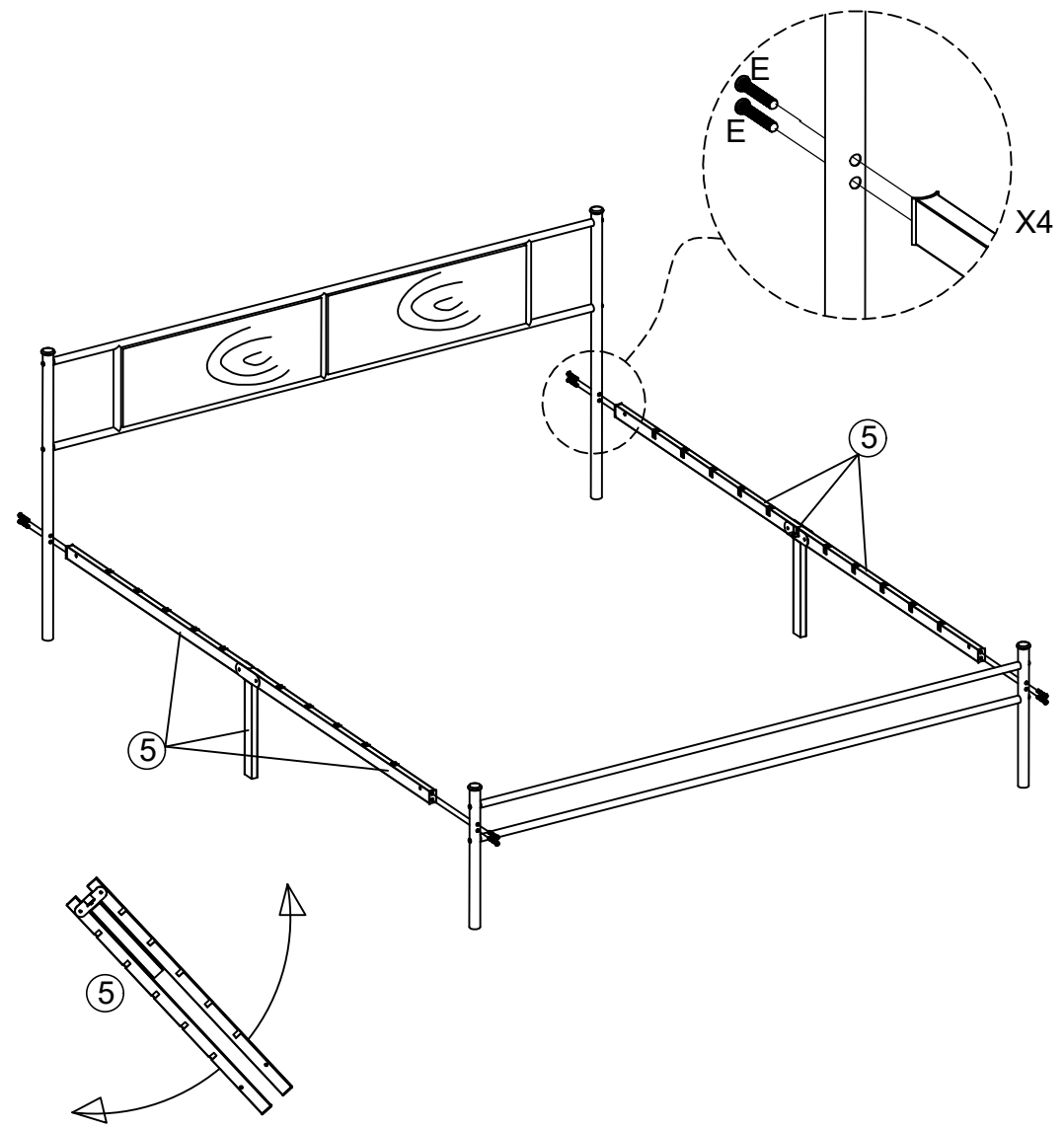

Step:3

	M8X45	E	8PCS		4#	F	1PC
---	-------	---	------	---	----	---	-----



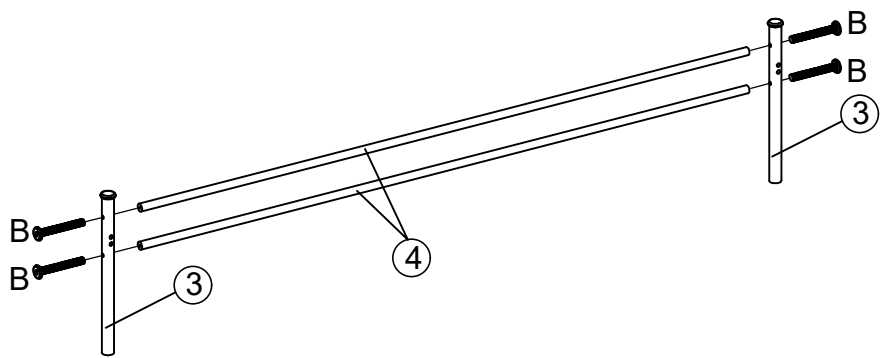

Step:2

	M6X45	B	4PCS		4#	F	1PC
---	-------	---	------	---	----	---	-----





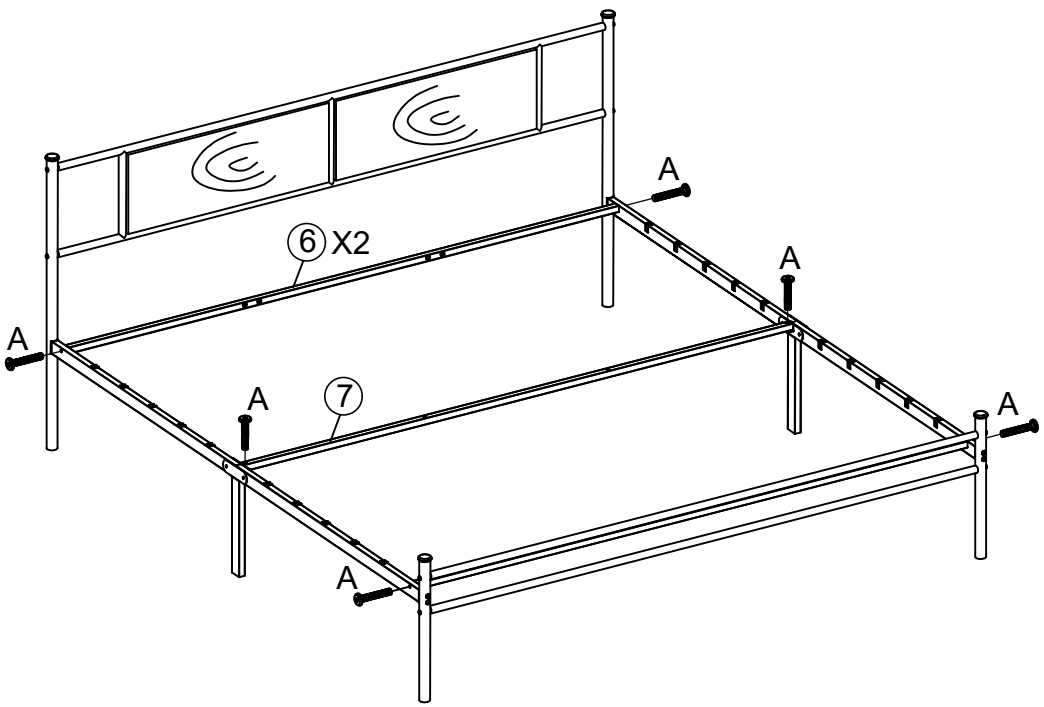

Step:4

	M6X35	A	6PCS
	4#	F	1PC



Step:5

	M8X45	E	4PCS
	M8X15	D	8PCS
	M6X55	C	2PCS
	4#	F	1PC

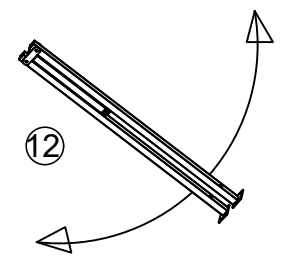
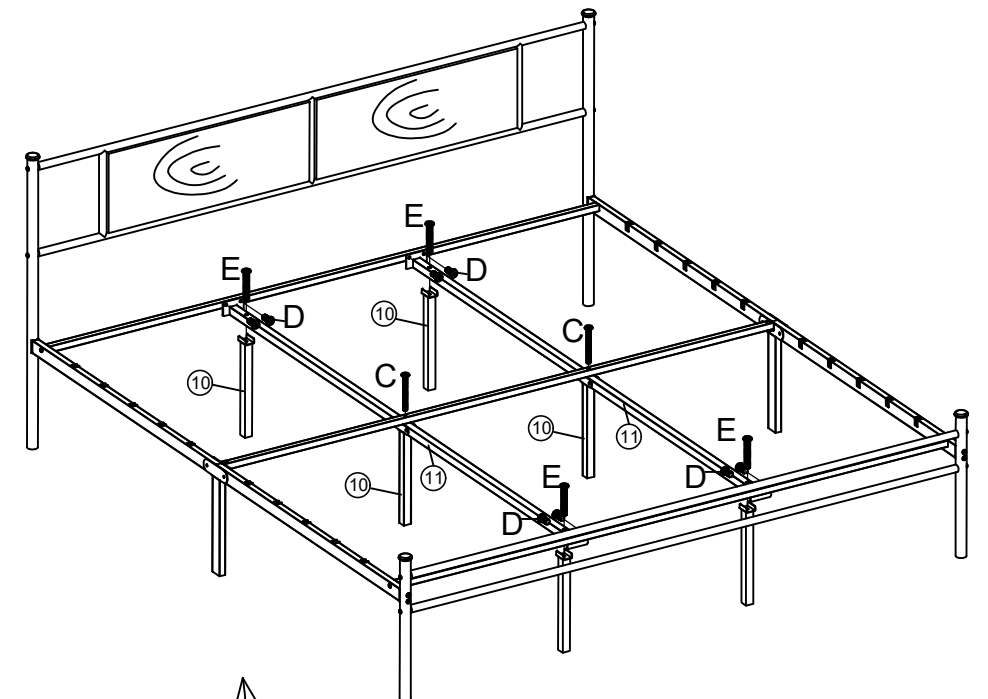

Step:6

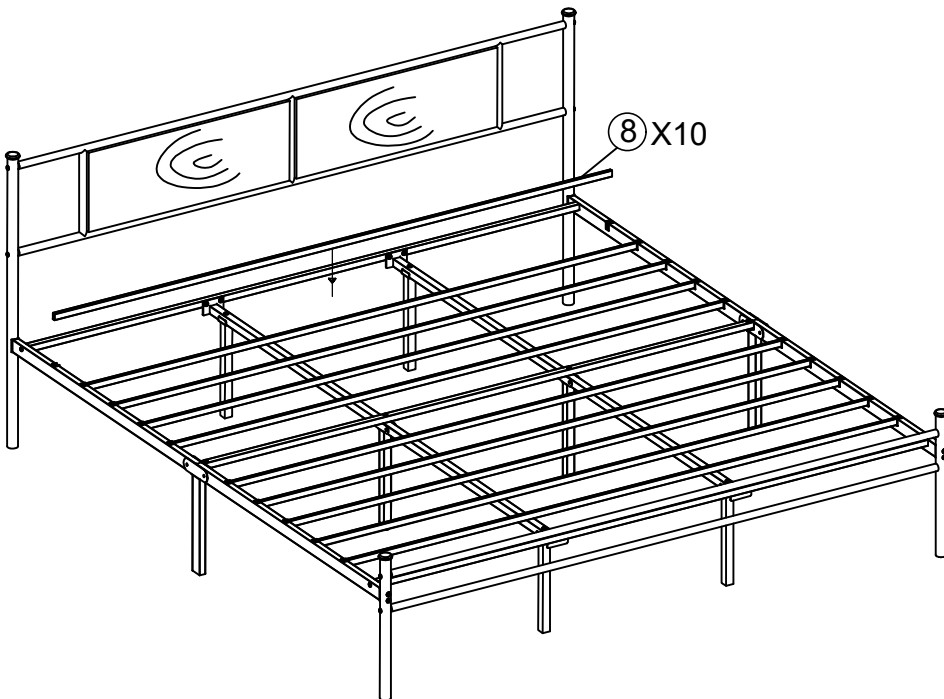

Step:7

