

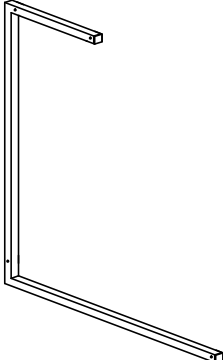
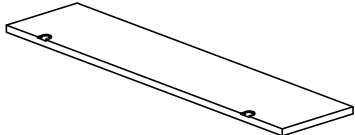
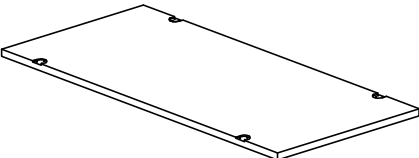
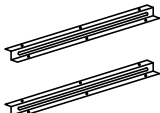
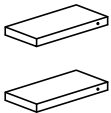
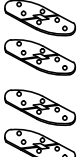
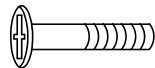
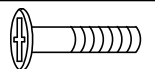

# Assembly Instructions

<p>①</p>  <p>x2</p>	<p>②</p>  <p>x4</p>	<p>③</p>  <p>x2</p>
<p>④</p>  <p>x1</p>	<p>⑤</p>  <p>x2</p>	<p>⑥</p>  <p>x2</p>
<p>⑦</p>  <p>x4</p>		

PART	QTY	SPEC	
<b>A</b>	8	6x40 MM	
<b>B</b>	4	6x35 MM	
PART	QTY	SPEC	
<b>C</b>	34	4x14 MM	