

2Pcs Teslin Lounge Chair

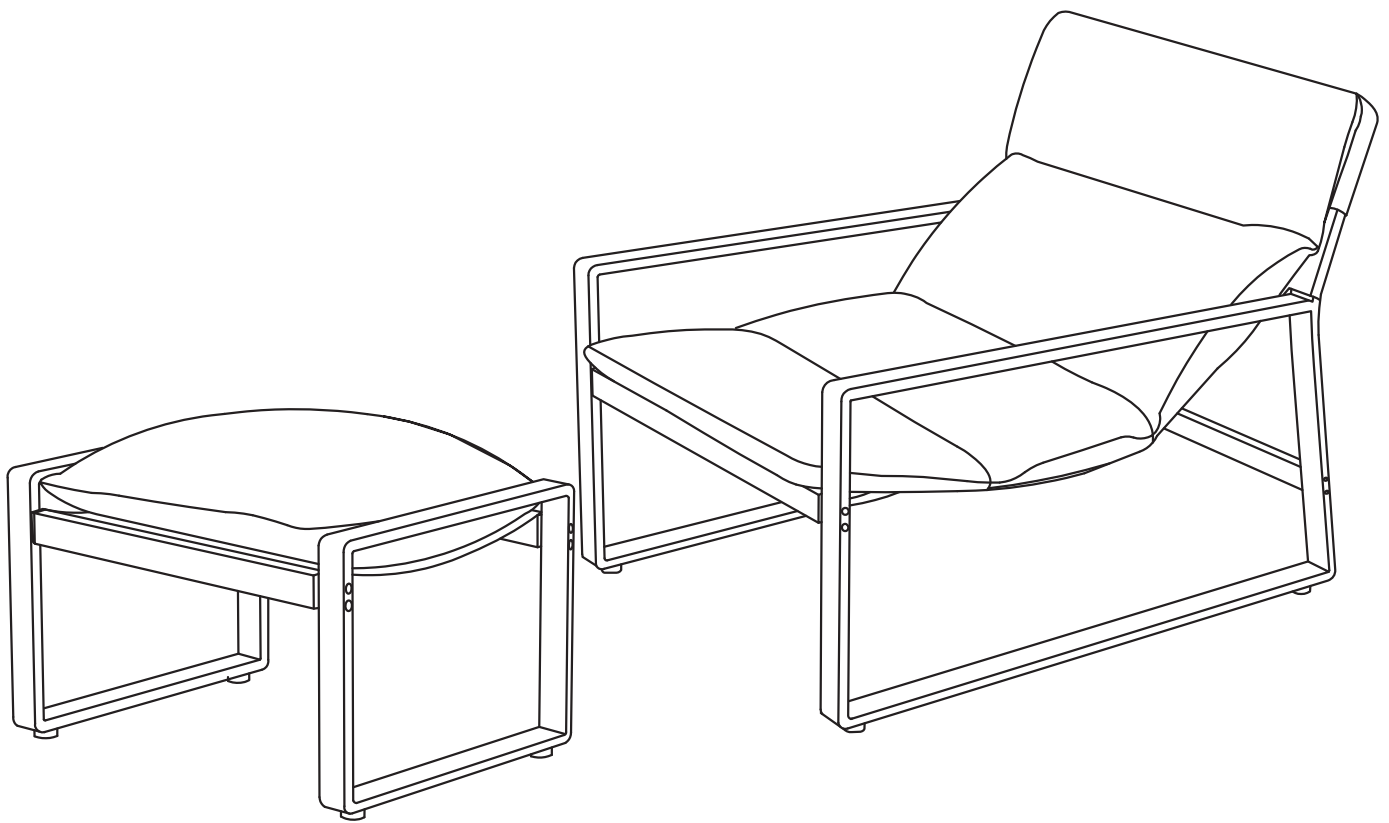

IMPORTANT
PLEASE READ BEFORE YOU COMMENCE ASSEMBLY

Follow the guidelines in this user guide to ensure correct assembly and care for this product.

2Pcs Teslin Lounge Chair

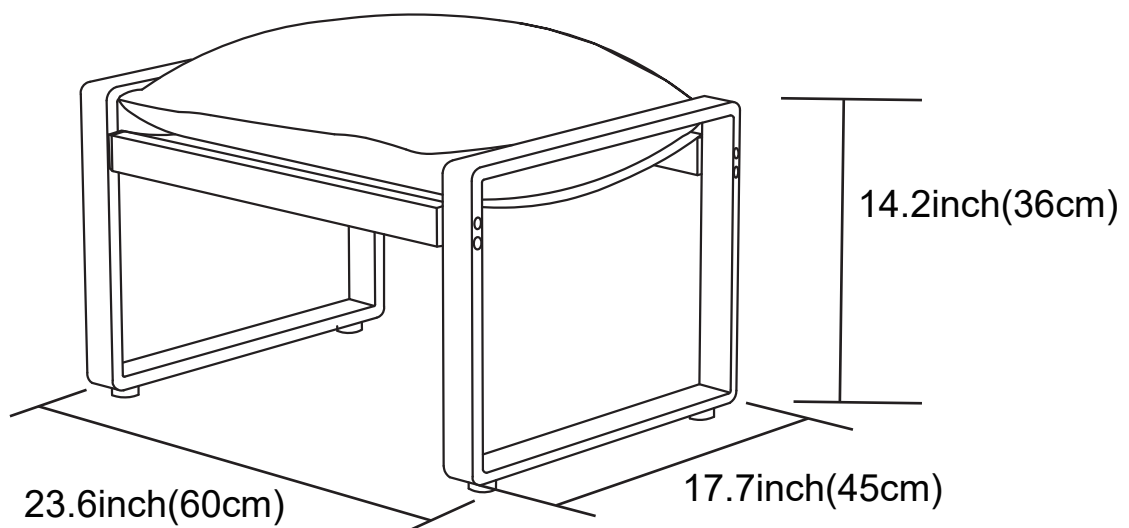
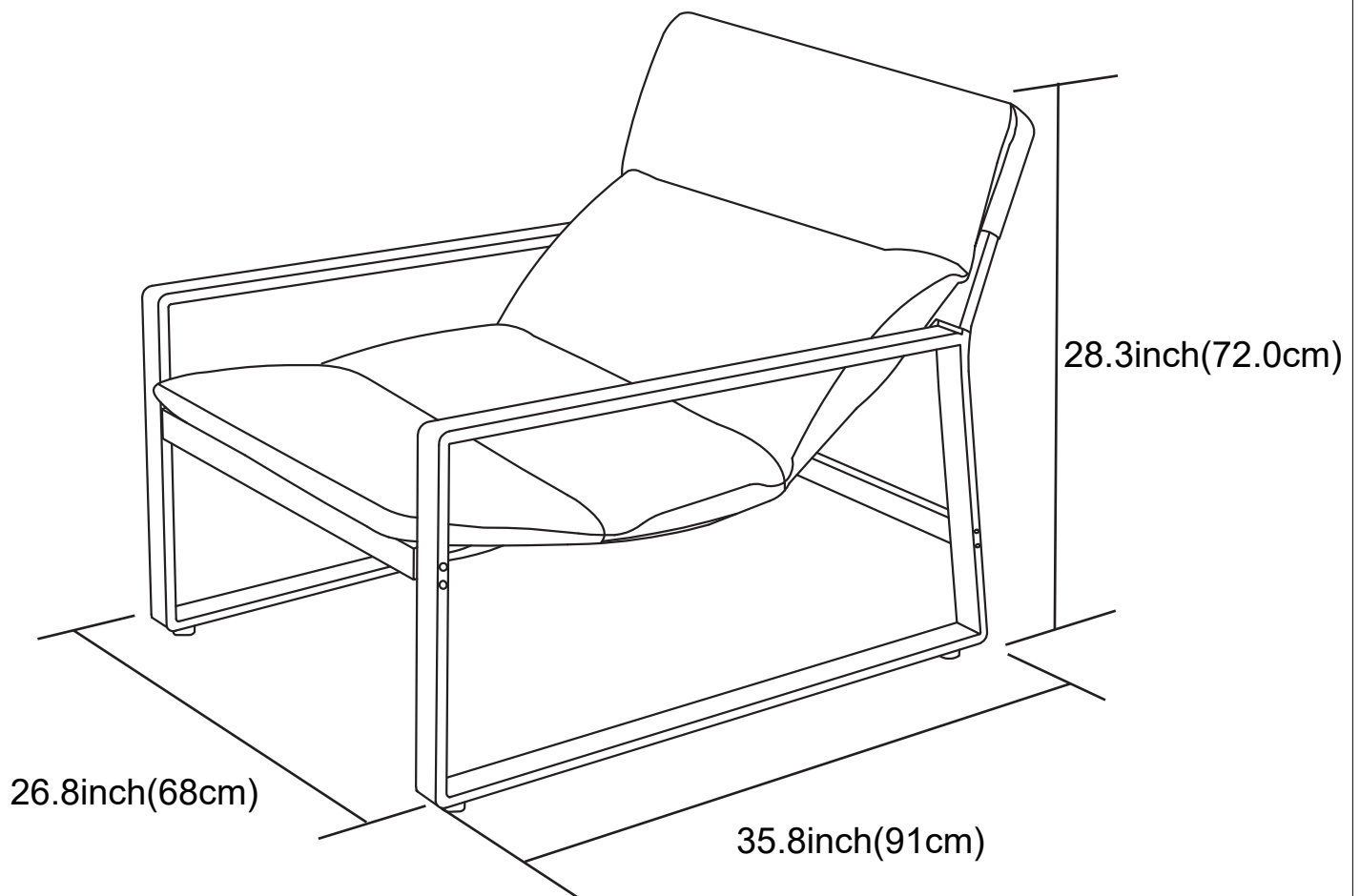

Catalog

Specifcations..... 01

Catalog..... 02

Notice..... 03

Part List And Screw Set List..... 04

How to Assemble The Footrest..... 05

How to Assemble The Chair..... 06



Before You Begin



Instructions are supplied in this manual and contain all appropriate information for your product.

Review all instructions before you begin and during assembly, follow the step sequence carefully for correct results.

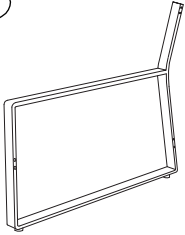

1. All parts are packaged within the carton. Separate contents of the carton by the part number while reviewing parts list. Check to be sure that you have all the necessary parts for building.
2. Familiarize yourself with the hardware and fasteners for easier use during construction.
3. The first few steps show how to join related parts which is to obtain larger sub-assemblies be used later.
4. Note that extra fasteners have been supplied for your convenience.
5. If you have an electric screwdriver, you can use it instead of the screwdriver we provide. An electric screwdriver can help you reduce assembly time.

PART LIST

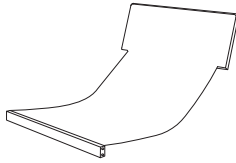
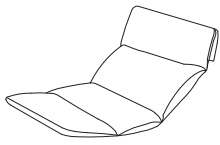
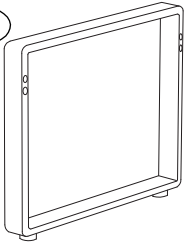
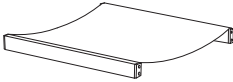
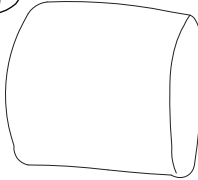
Part List

| | | | |
|---|---|--|---|
| <p>(L001)</p>  | <p>(L002)</p>  | <p>(L003)</p>  | <p>(L004)</p>  |
| <p>2PCS</p> | <p>2PCS</p> | <p>1PC</p> | <p>1PC</p> |
| <p>(L005)</p>  | <p>(L006)</p>  | <p>(L007)</p>  | |
| <p>2PCS</p> | <p>1PC</p> | <p>1PC</p> | |

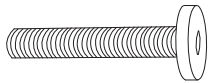
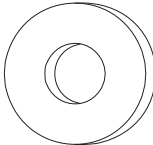
Screw Set

| | | |
|---|--|---|
| <p>(A)</p>  <p>M6*50</p> | <p>(B)</p>  <p>M6</p> | <p>(C)</p>  <p>4*4</p> |
| <p>20PCS</p> | <p>20PCS</p> | <p>1PC</p> |

Extra (Screw Set)

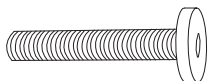
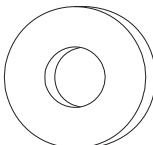
| | | |
|---|--|--|
| <p>(A)</p>  <p>M6*50</p> | <p>(B)</p>  <p>M6</p> | |
| <p>2PCS</p> | <p>2PCS</p> | |





How To Assemble The Footrest

STEP 01: Secure the Teslin seat to the footrest's two legs using screws.

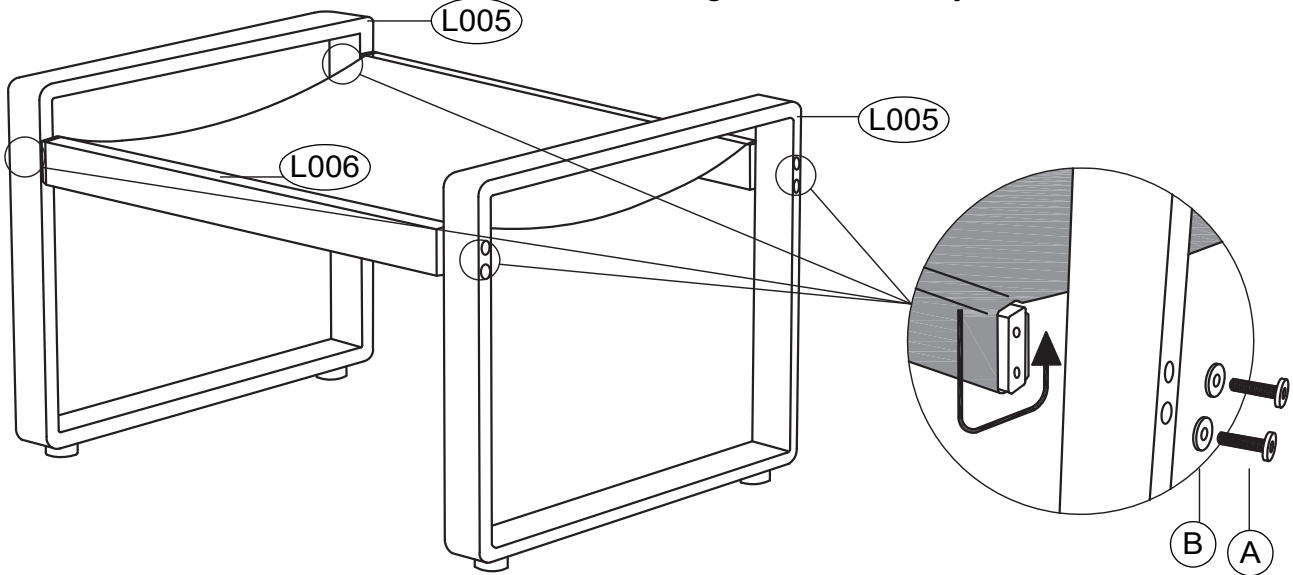
NOTE: Wrap the Teslin fabric around the metal support rod once before attaching it to the footrest legs.

First secure all four screws, then tighten them fully.



| | | | | | | | | | | | | | | |
|------|---|----|------|---|----|---|---|----|---|---|----|---|---|----|
| L005 |  | x2 | L006 |  | x1 | A |  | x8 | B |  | x8 | C |  | x1 |
|------|---|----|------|---|----|---|---|----|---|---|----|---|---|----|

STEP 02: Place the cushion on the Teslin seat surface to complete assembly.

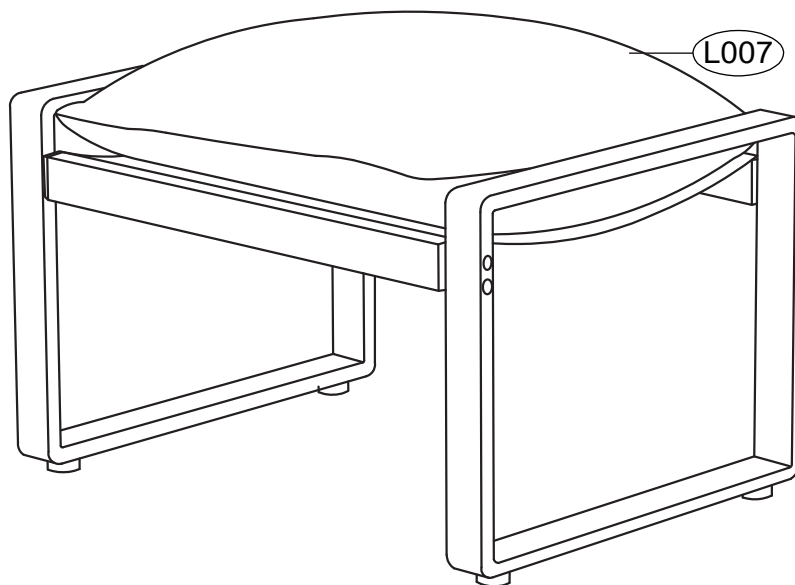





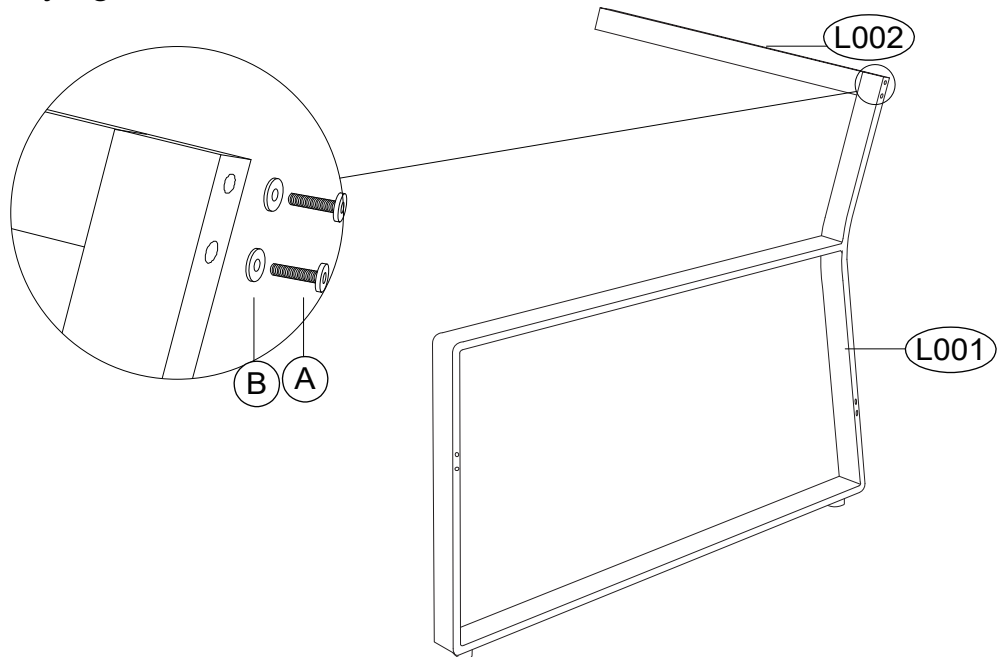

| | | |
|------|---|----|
| L007 |  | x1 |
|------|---|----|

How To Assemble The Chair

STEP 01: Secure the armrest (L001) to the central support rod (L002) using screws.

NOTE: Do not fully tighten the screws.





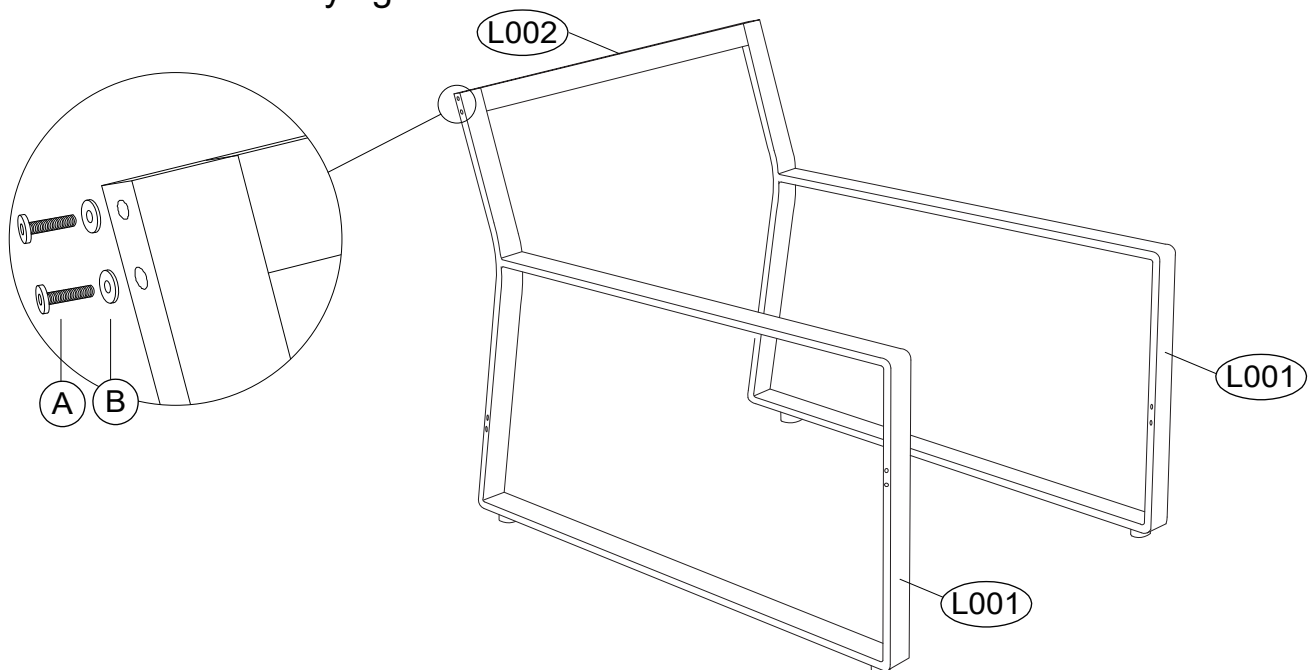

| | | | | | | | | | | | | | | |
|------|---|----|------|---|----|---|---|----|---|---|----|---|---|----|
| L001 |  | x1 | L002 |  | x1 | A |  | x2 | B |  | x2 | C |  | x1 |
|------|---|----|------|---|----|---|---|----|---|---|----|---|---|----|

STEP 02: Secure the other central support rod (L002) with screws to join the two armrests together at the position shown in the diagram.

NOTE: Do not fully tighten the screws.







| | | | | | | | | | | | |
|------|---|----|---|---|----|---|---|----|---|---|----|
| L001 |  | x1 | A |  | x2 | B |  | x2 | C |  | x1 |
|------|---|----|---|---|----|---|---|----|---|---|----|

Installation steps

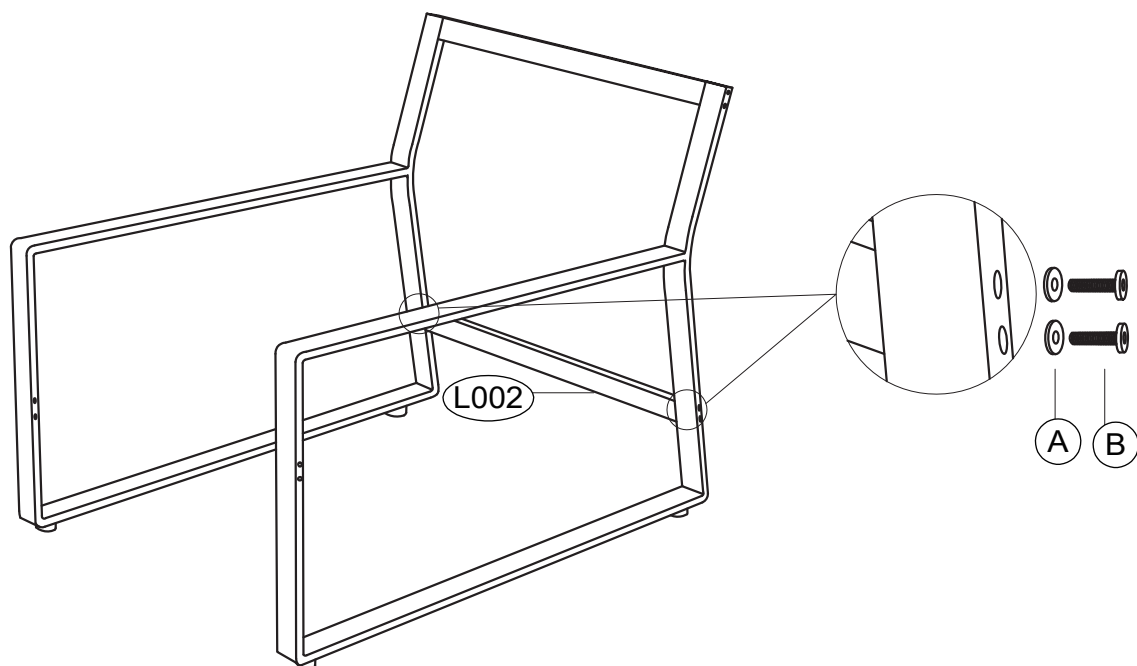
STEP 03: Secure the other armrest (L001) to the opposite side of the recently installed the central support rod (L002) using screws.

NOTE: Do not fully tighten the screws.



| | | | | | | | | | | | |
|------|---|----|---|---|----|---|---|----|---|---|----|
| L002 |  | x1 | A |  | x4 | B |  | x4 | C |  | x1 |
|------|---|----|---|---|----|---|---|----|---|---|----|

STEP 04: Place the Teslin fabric seat cover (L003) over the headrest section of the lounge.

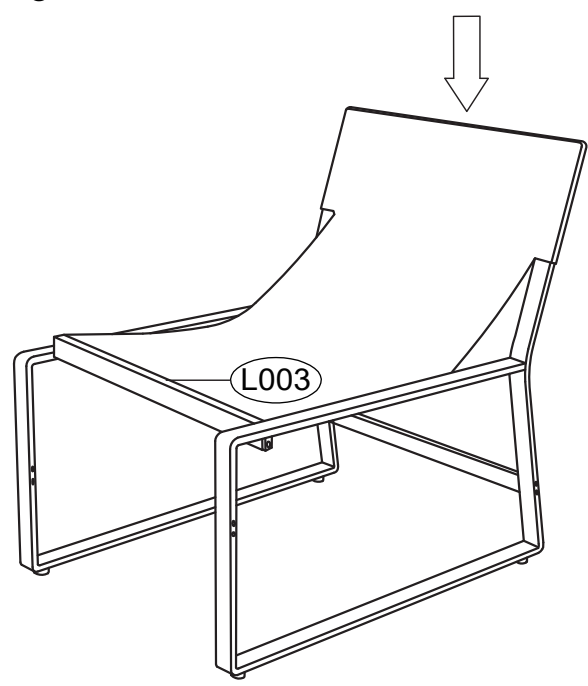

| | | |
|------|---|----|
| L003 |  | x1 |
|------|---|----|



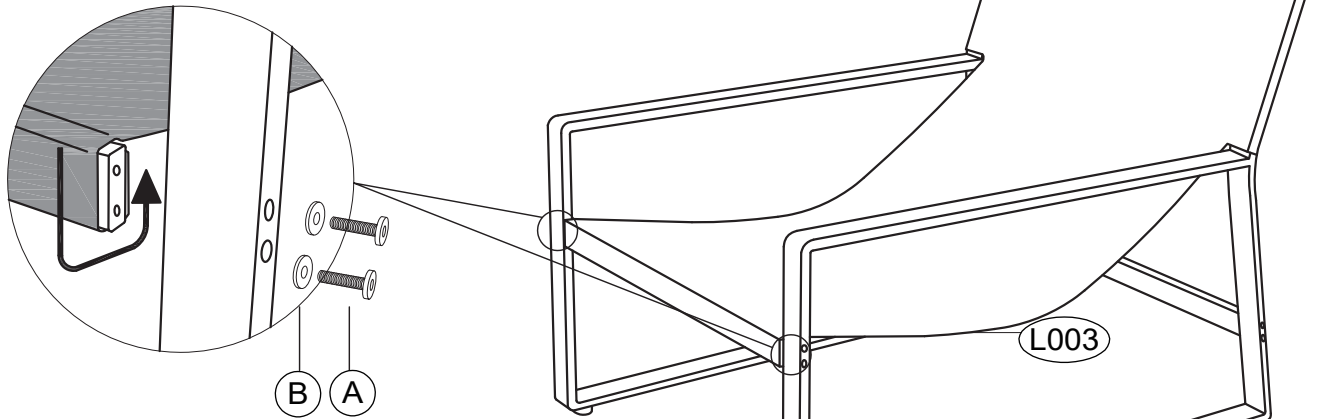

Installation steps

STEP 05: Secure the metal connectors, already fitted with Teslin fabric(L003), to each armrest using screws.

NOTE: Ensure all screws are fully tightened.



You may wrap the Teslin fabric around the metal connectors several times according to your sitting or reclining preferences to adjust the recliner's minimum height and reclining angle.

| | | | | | | | | | | | |
|------|---|----|---|---|----|---|---|----|---|---|----|
| L003 |  | x1 | A |  | x4 | B |  | x4 | G |  | x1 |
|------|---|----|---|---|----|---|---|----|---|---|----|

STEP 06: Place the cushion cover (L004) over the lounge.

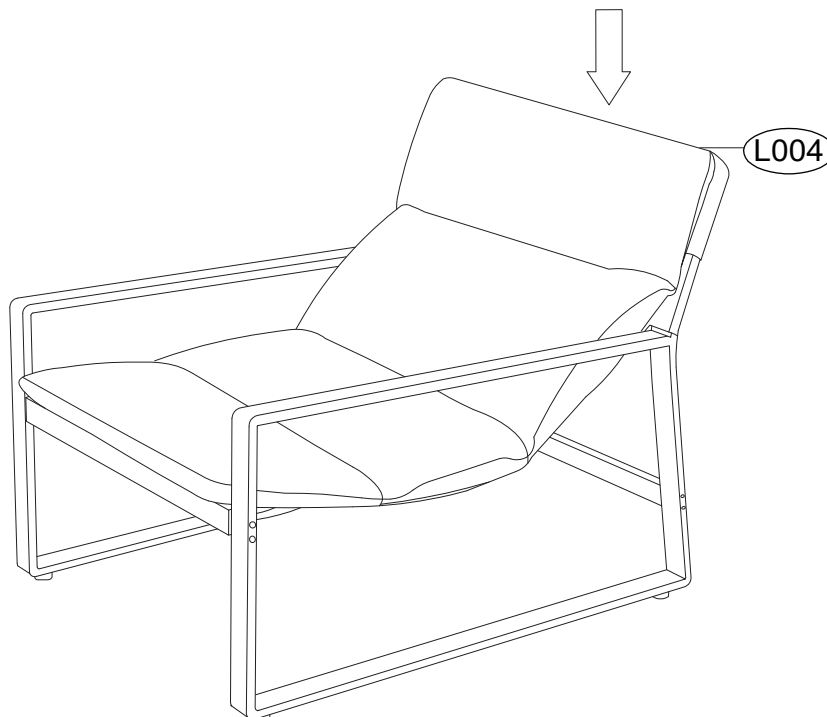

| | | |
|------|---|----|
| L004 |  | x2 |
|------|---|----|

2 Stück Teslin-Liegestuhl

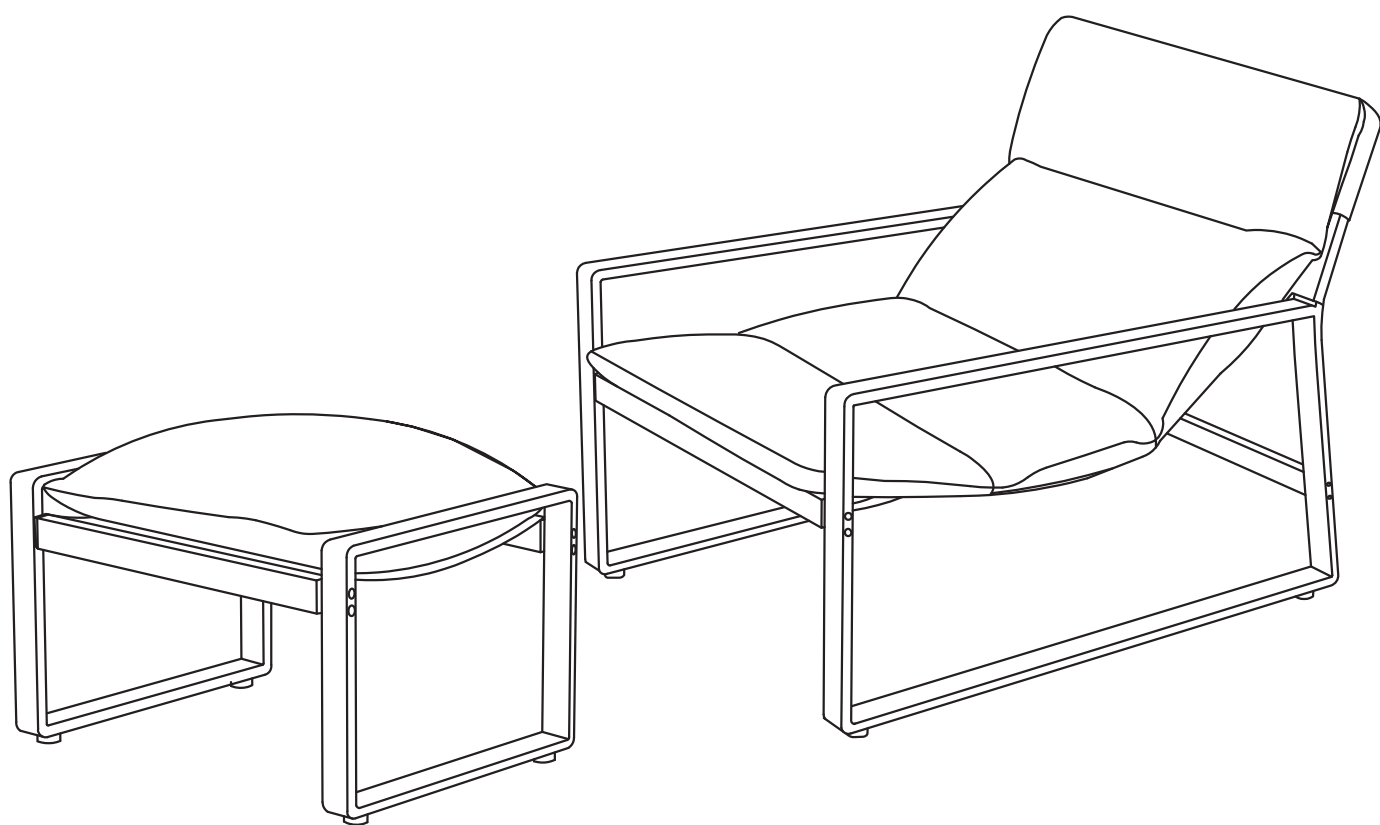

WICHTIG

BITTE VOR BEGINN DER MONTAGE LESEN

Befolgen Sie die Anweisungen in dieser Bedienungsanleitung, um eine korrekte Montage und Pflege dieses Produkts sicherzustellen.

2 Stück Teslin-Liegestuhl

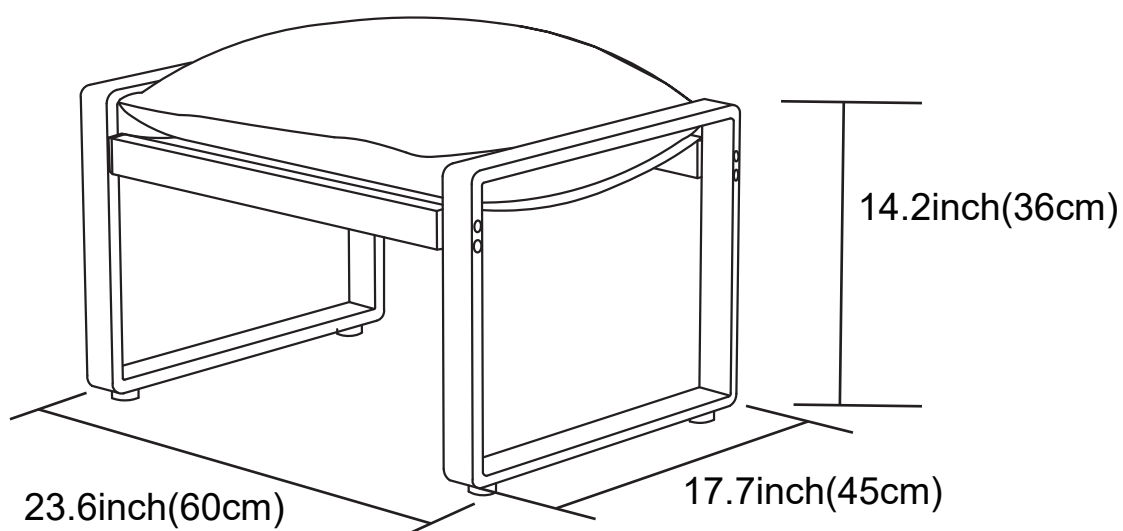
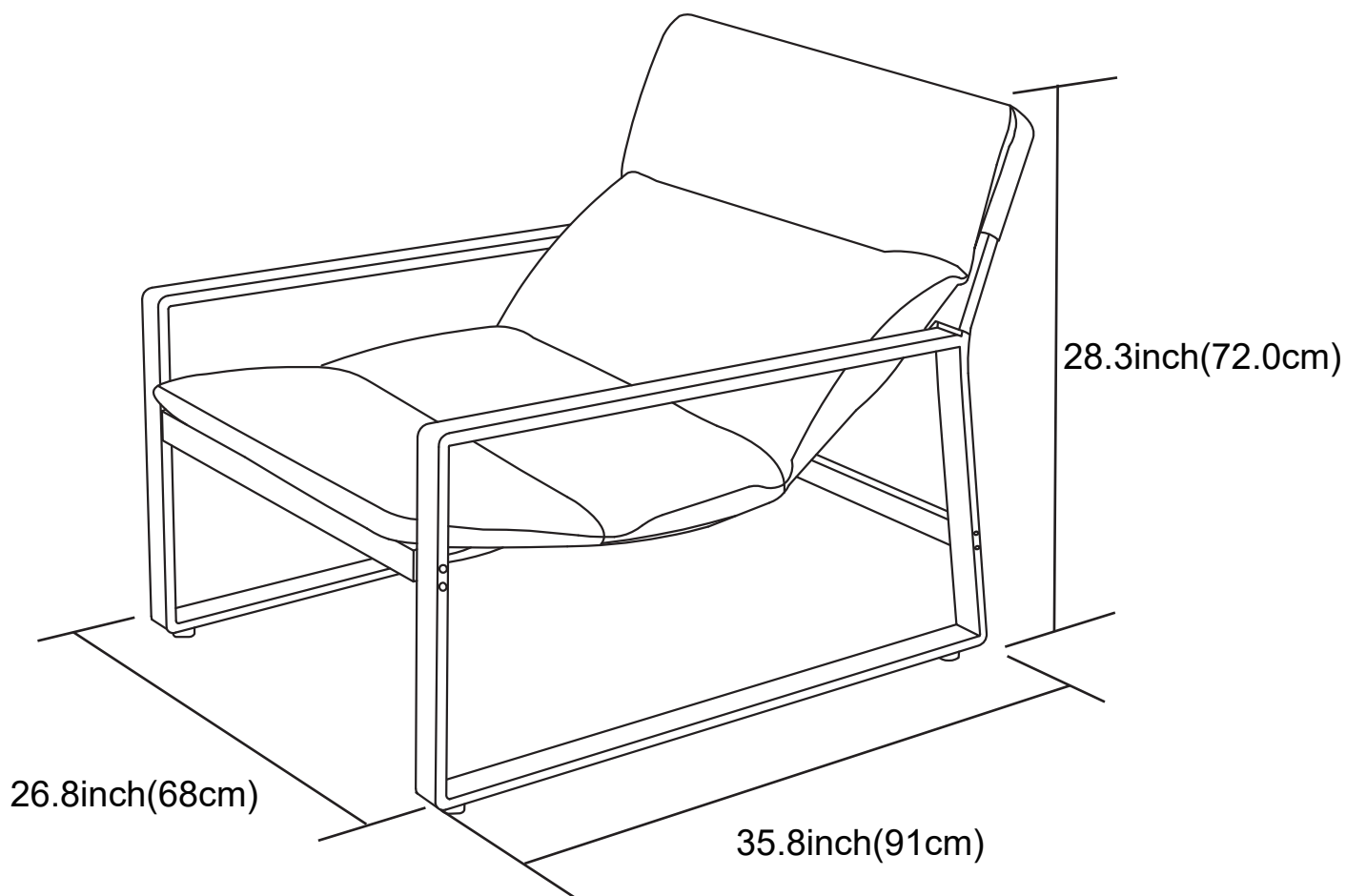

Katalog

| | |
|--|----|
| Spezifikationen..... | 01 |
| Katalog..... | 02 |
| Hinweis..... | 03 |
| Teileliste und Schraubensatzliste..... | 04 |
| Montage der Fußstütze..... | 05 |
| Montage der Stühle..... | 06 |



Bevor Sie beginnen

Die Anweisungen in diesem Handbuch enthalten alle relevanten Informationen zu Ihrem Produkt.

Lesen Sie alle Anweisungen vor Beginn und während der Montage sorgfältig durch und befolgen Sie die einzelnen Schritte genau, um ein korrektes Ergebnis zu erzielen.

1. Alle Teile sind im Karton verpackt. Sortieren Sie den Inhalt des Kartons anhand der Teilenummern, während Sie die Teileliste durchgehen. Vergewissern Sie sich, dass Sie alle für den Zusammenbau erforderlichen Teile haben.
2. Machen Sie sich mit den Beschlägen und Befestigungselementen vertraut, um den Zusammenbau zu erleichtern.
3. Die ersten Schritte zeigen, wie Sie verwandte Teile miteinander verbinden, um größere Baugruppen zu erhalten, die später verwendet werden.
4. Beachten Sie, dass Ihnen zusätzliche Befestigungselemente zur Verfügung gestellt wurden.
5. Wenn Sie einen Elektroschrauber besitzen, können Sie diesen anstelle des mitgelieferten Schraubendrehers verwenden. Mit einem Elektroschrauber können Sie die Montagezeit verkürzen.

TEILELISTE

Teileliste

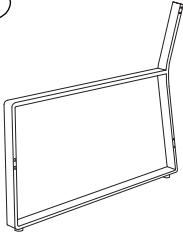
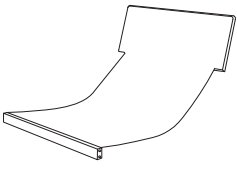
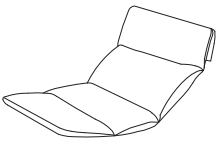
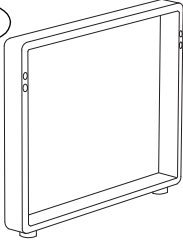
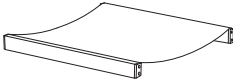
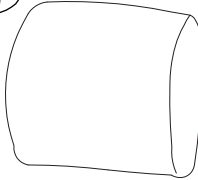
| | | | |
|---|---|--|---|
| <p>L001</p>  | <p>L002</p>  | <p>L003</p>  | <p>L004</p>  |
| <p>2PCS</p> | <p>2PCS</p> | <p>1PC</p> | <p>1PC</p> |
| <p>L005</p>  | <p>L006</p>  | <p>L007</p>  | |
| <p>2PCS</p> | <p>1PC</p> | <p>1PC</p> | |

Schraubensatz

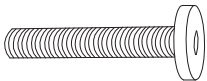
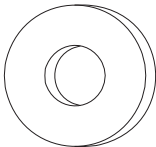
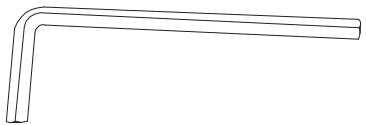
| | | |
|---|--|---|
| <p>A</p>  <p>M6*50</p> | <p>B</p>  <p>M6</p> | <p>C</p>  <p>4*4</p> |
| <p>20PCS</p> | <p>20PCS</p> | <p>1PC</p> |

Extra (Schraubensatz)

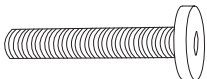
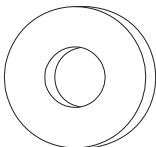
| | | |
|---|--|--|
| <p>A</p>  <p>M6*50</p> | <p>B</p>  <p>M6</p> | |
| <p>2PCS</p> | <p>2PCS</p> | |

How To Assemble The Footrest

SCHRITT 01: Befestigen Sie den Teslin-Sitz mit Schrauben an den beiden Beinen der Fußstütze.

HINWEIS: Wickeln Sie den Teslin-Stoff einmal um die Metallstützstange, bevor Sie ihn an den Beinen der Fußstütze befestigen.
Befestigen Sie zunächst alle vier Schrauben und ziehen Sie sie dann vollständig fest.

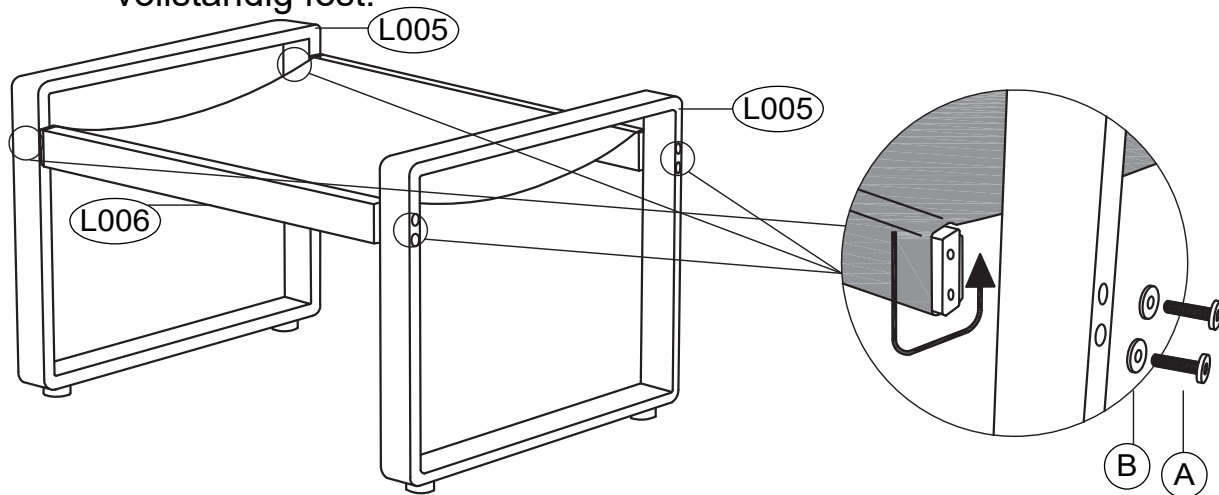

| | | | | | | | | | | | | | | |
|------|--|----|------|--|----|---|--|----|---|--|----|---|--|----|
| L005 | | x2 | L006 | | x1 | A | | x8 | B | | x8 | C | | x1 |
|------|--|----|------|--|----|---|--|----|---|--|----|---|--|----|

SCHRITT 02: Legen Sie das Polster auf die Teslin-Sitzfläche, um die Montage abzuschließen.

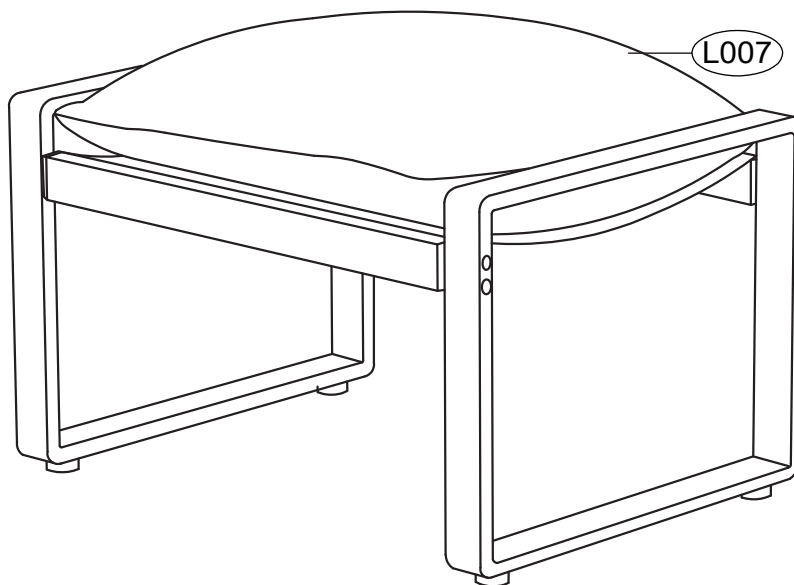





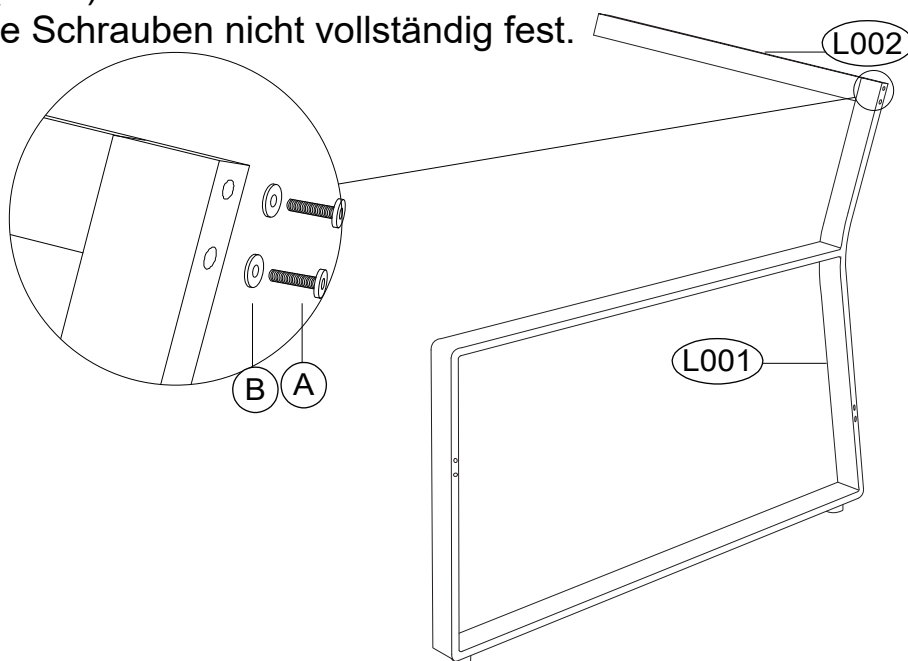

| | | |
|------|--|----|
| L007 | | x1 |
|------|--|----|

How To Assemble The Chair

SCHRITT 01: Befestigen Sie die Armlehne (L001) mit Schrauben an der zentralen Stützstange (L002).

HINWEIS: Ziehen Sie die Schrauben nicht vollständig fest.





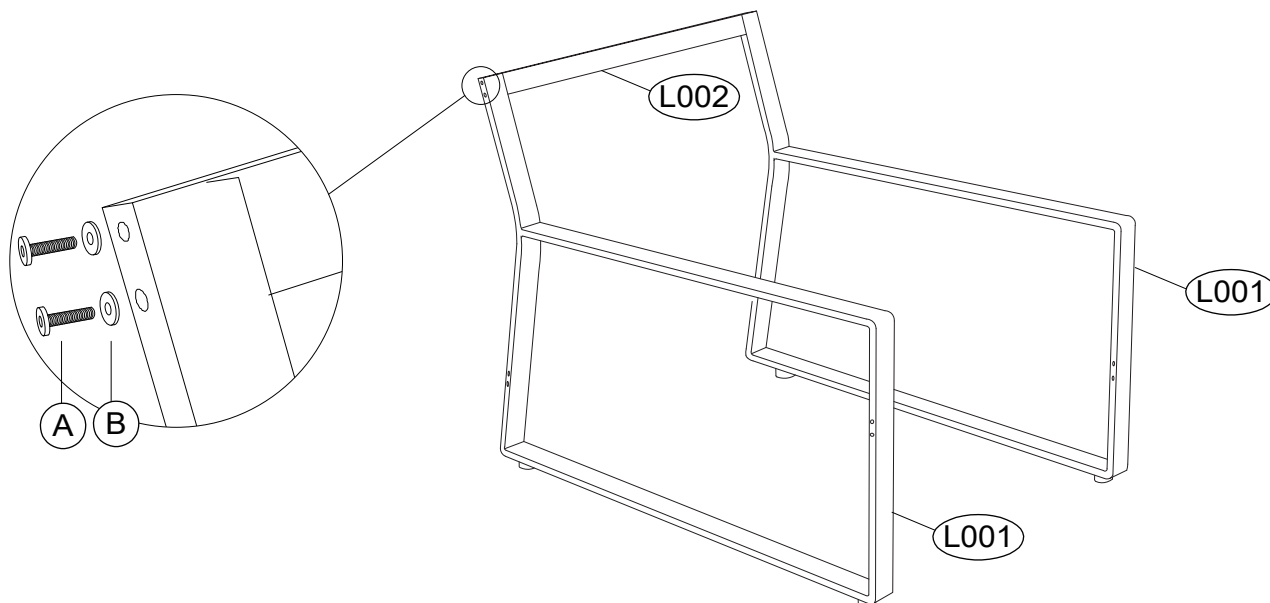

| | | | | | | | | | | | | | | |
|------|---|----|------|---|----|---|---|----|---|---|----|---|---|----|
| L001 |  | x1 | L002 |  | x1 | A |  | x2 | B |  | x2 | C |  | x1 |
|------|---|----|------|---|----|---|---|----|---|---|----|---|---|----|

SCHRITT 02: Befestigen Sie die andere zentrale Stützstange (L002) mit Schrauben, um die beiden Armlehnen an der in der Abbildung gezeigten Position miteinander zu verbinden.

HINWEIS: Ziehen Sie die Schrauben nicht vollständig fest.





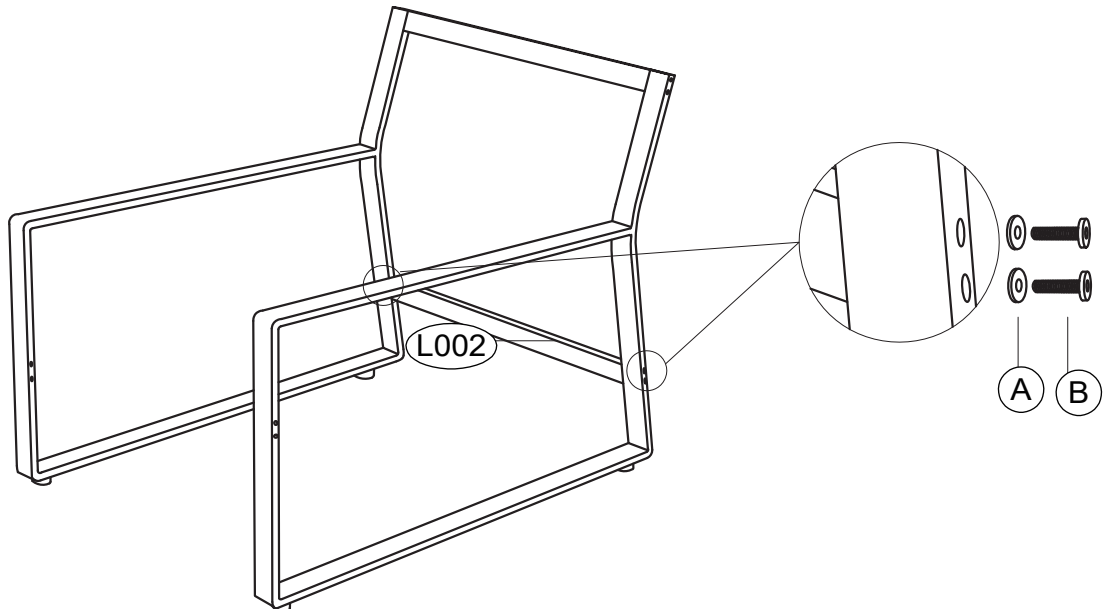

| | | | | | | | | | | | |
|------|---|----|---|---|----|---|---|----|---|---|----|
| L001 |  | x1 | A |  | x2 | B |  | x2 | C |  | x1 |
|------|---|----|---|---|----|---|---|----|---|---|----|

SCHRITT 03: Befestigen Sie die andere Armlehne (L001) mit Schrauben an der gegenüberliegenden Seite der gerade montierten zentralen Stützstange (L002).

HINWEIS: Ziehen Sie die Schrauben nicht vollständig fest.



| | | | | | | | | | | | |
|------|---|----|---|---|----|---|---|----|---|---|----|
| L002 |  | x1 | A |  | x4 | B |  | x4 | C |  | x1 |
|------|---|----|---|---|----|---|---|----|---|---|----|

SCHRITT 04: Legen Sie den Sitzbezug aus Teslin-Gewebe (L003) über den Kopfstützenbereich der Liege.

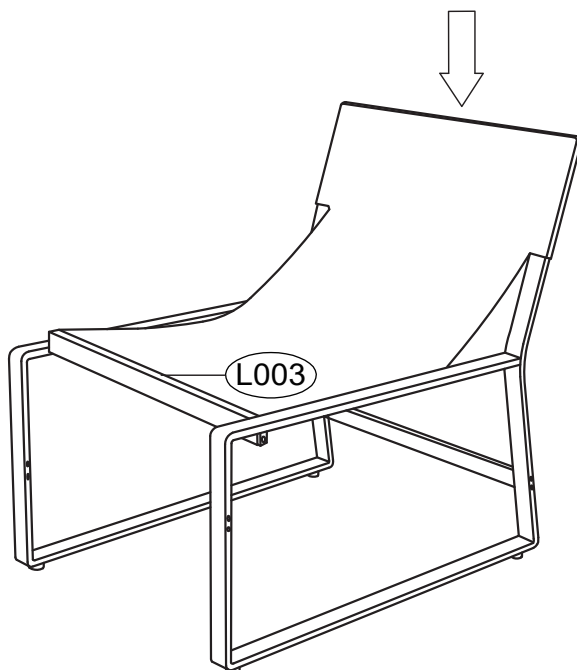



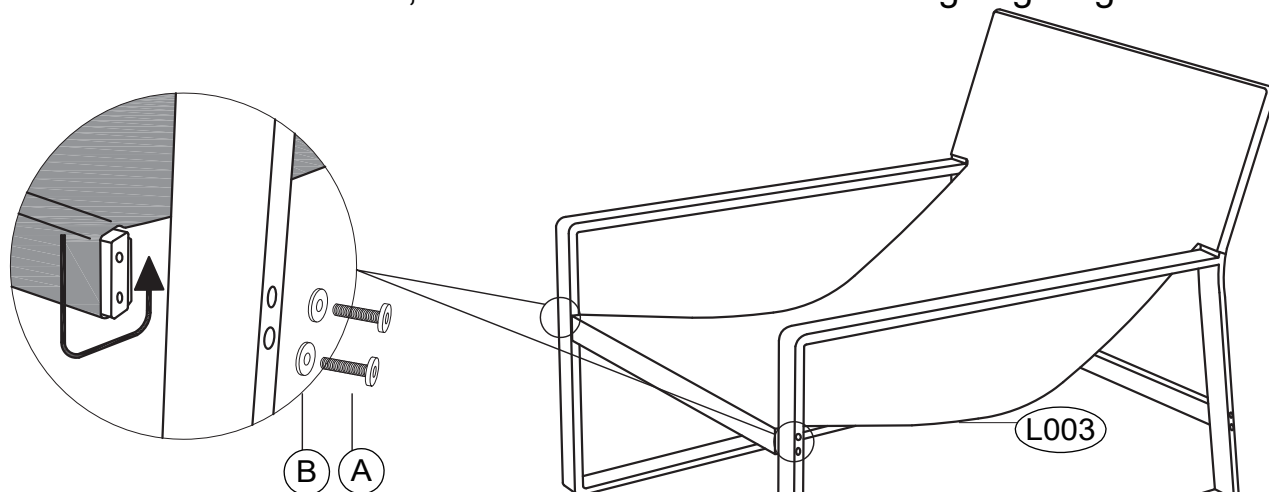

| | | |
|------|---|----|
| L003 |  | x1 |
|------|---|----|

SCHRITT 05: Befestigen Sie die Metallverbinder, die bereits mit Teslin-Gewebe (L003) versehen sind, mit Schrauben an jeder Armlehne.

HINWEIS: Stellen Sie sicher, dass alle Schrauben vollständig angezogen sind.



Sie können das Teslin-Gewebe entsprechend Ihren Sitz- oder Liegevorlieben mehrmals um die Metallverbinder wickeln, um die Mindesthöhe und den Neigungswinkel des Liegestuhls anzupassen.

| | | | | | | | | | | | |
|------|---|----|---|---|----|---|---|----|---|---|----|
| L003 |  | x1 | A |  | x4 | B |  | x4 | G |  | x1 |
|------|---|----|---|---|----|---|---|----|---|---|----|

SCHRITT 06: Legen Sie den Kissenbezug (L004) über die Liege.

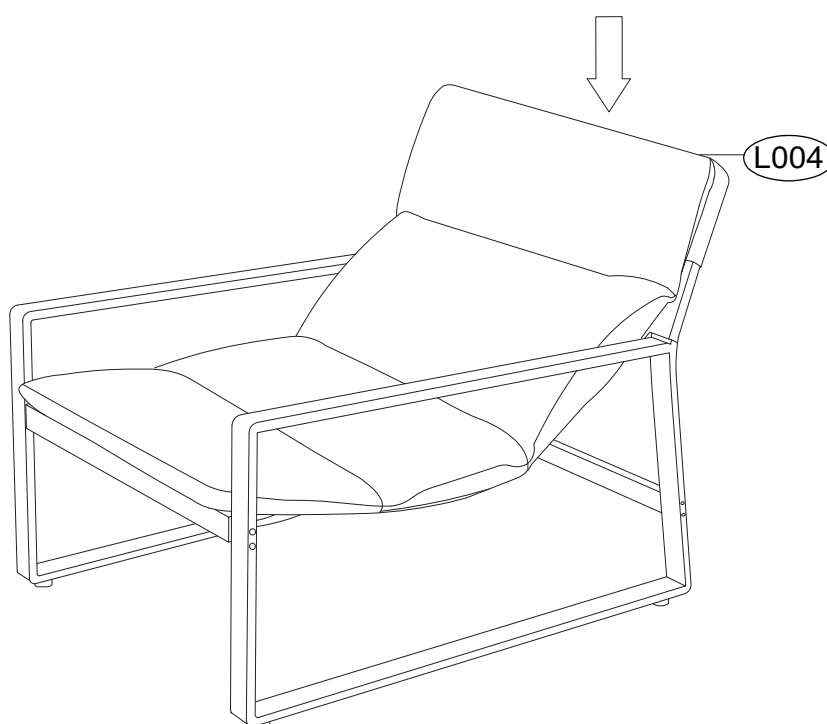

| | | |
|------|---|----|
| L004 |  | x2 |
|------|---|----|

2 pièces Fauteuil Teslin

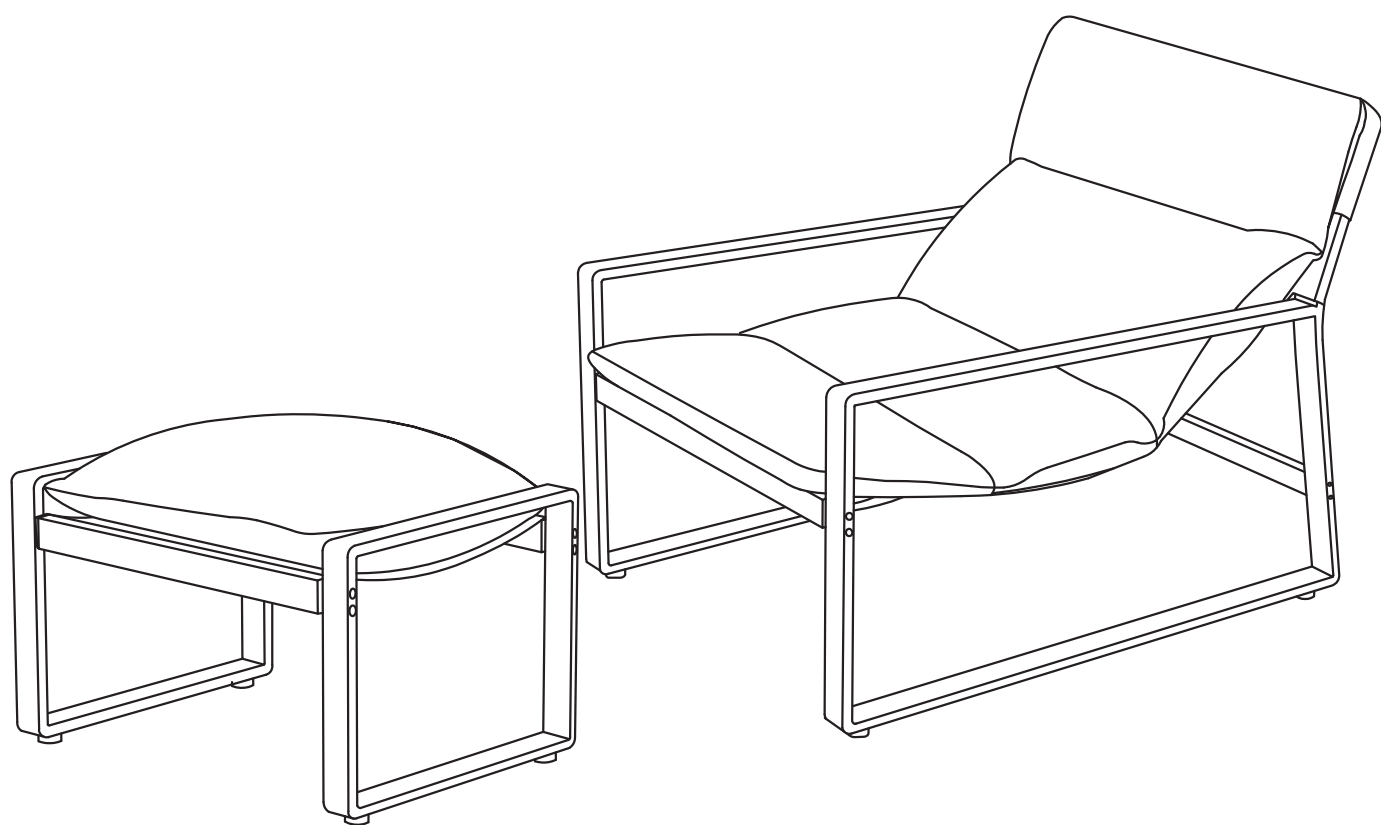

IMPORTANT

VEUILLEZ LIRE AVANT DE COMMENCER L'ASSEMBLAGE

Suivez les instructions contenues dans ce guide d'utilisation afin d'assurer un assemblage et un entretien corrects de ce produit.

2 pièces Fauteuil Teslin

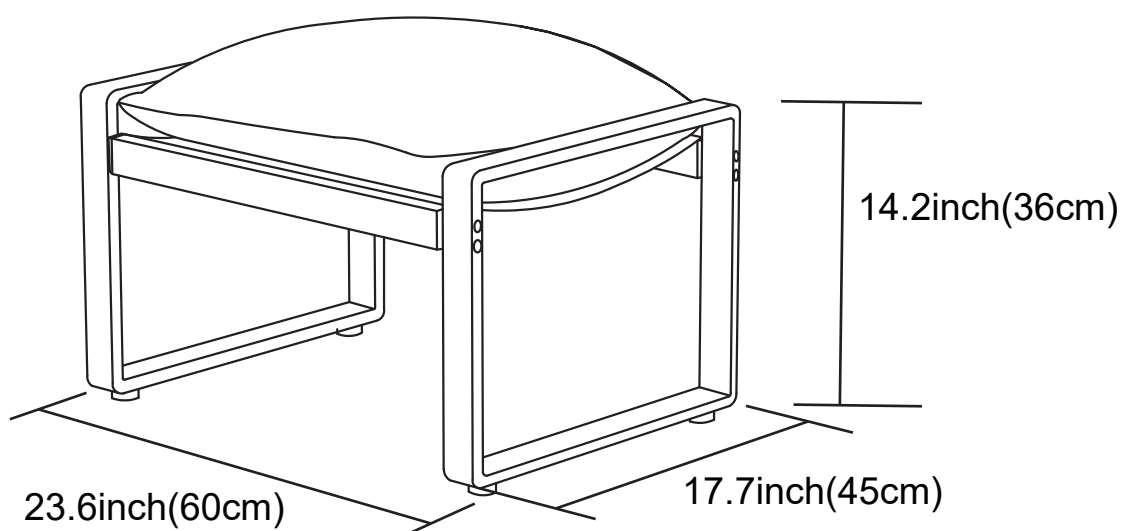
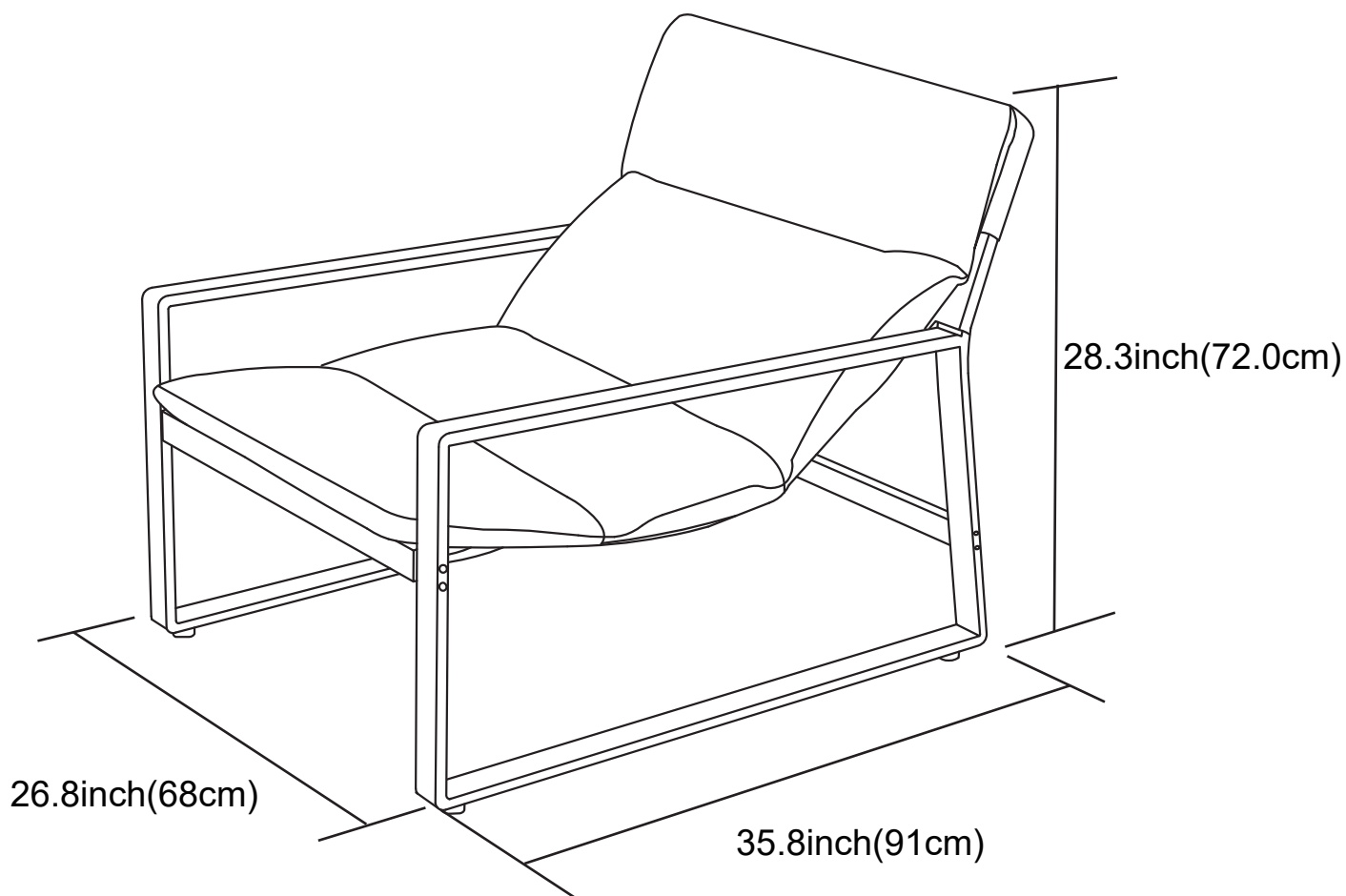

Catalogue

| | |
|--|----|
| Spécifications..... | 01 |
| Catalogue..... | 02 |
| Avis..... | 03 |
| Liste des pièces et liste des vis..... | 04 |
| Comment assembler le repose-pieds..... | 05 |
| Comment assembler la chaise..... | 06 |



Avant de commencer



Les instructions fournies dans ce manuel contiennent toutes les informations nécessaires concernant votre produit.

Veillez lire attentivement toutes les instructions avant de commencer et, pendant l'assemblage, suivez scrupuleusement les étapes indiquées afin d'obtenir un résultat correct.

1. Toutes les pièces sont emballées dans le carton. Triez le contenu du carton par numéro de pièce tout en consultant la liste des pièces. Vérifiez que vous disposez de toutes les pièces nécessaires à la construction.
2. Familiarisez-vous avec le matériel et les fixations afin de faciliter leur utilisation pendant la construction.
3. Les premières étapes montrent comment assembler les pièces connexes afin d'obtenir des sous-ensembles plus grands qui seront utilisés ultérieurement.
4. Veuillez noter que des fixations supplémentaires ont été fournies pour votre commodité.
5. Si vous disposez d'un tournevis électrique, vous pouvez l'utiliser à la place du tournevis que nous fournissons. Un tournevis électrique peut vous aider à réduire le temps d'assemblage.

LISTE DES PIÈCES

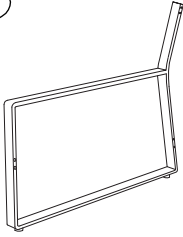
Liste des pièces

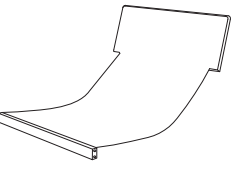
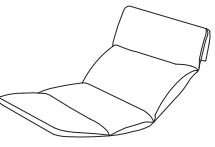
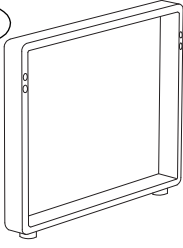
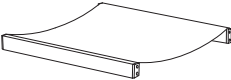
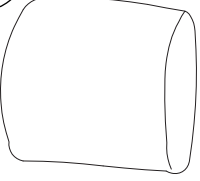
| | | | |
|---|---|--|---|
| <p>(L001)</p>  | <p>(L002)</p>  | <p>(L003)</p>  | <p>(L004)</p>  |
| 2PCS | 2PCS | 1PC | 1PC |
| <p>(L005)</p>  | <p>(L006)</p>  | <p>(L007)</p>  | |
| 2PCS | 1PC | 1PC | |

Jeu de vis

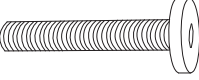
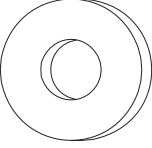
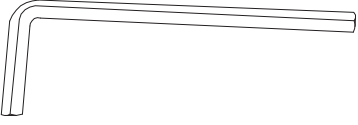
| | | |
|---|--|---|
| <p>(A)</p>  <p>M6*50</p> | <p>(B)</p>  <p>M6</p> | <p>(C)</p>  <p>4*4</p> |
| 20PCS | 20PCS | 1PC |

Supplément (jeu de vis)

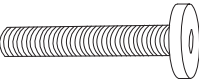
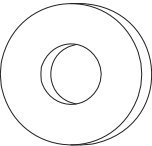
| | | |
|---|--|--|
| <p>(A)</p>  <p>M6*50</p> | <p>(B)</p>  <p>M6</p> | |
| 2PCS | 2PCS | |





Comment assembler le repose-pieds

ÉTAPE 01 : Fixez le siège en Teslin aux deux pieds du repose-pieds à l'aide de vis.

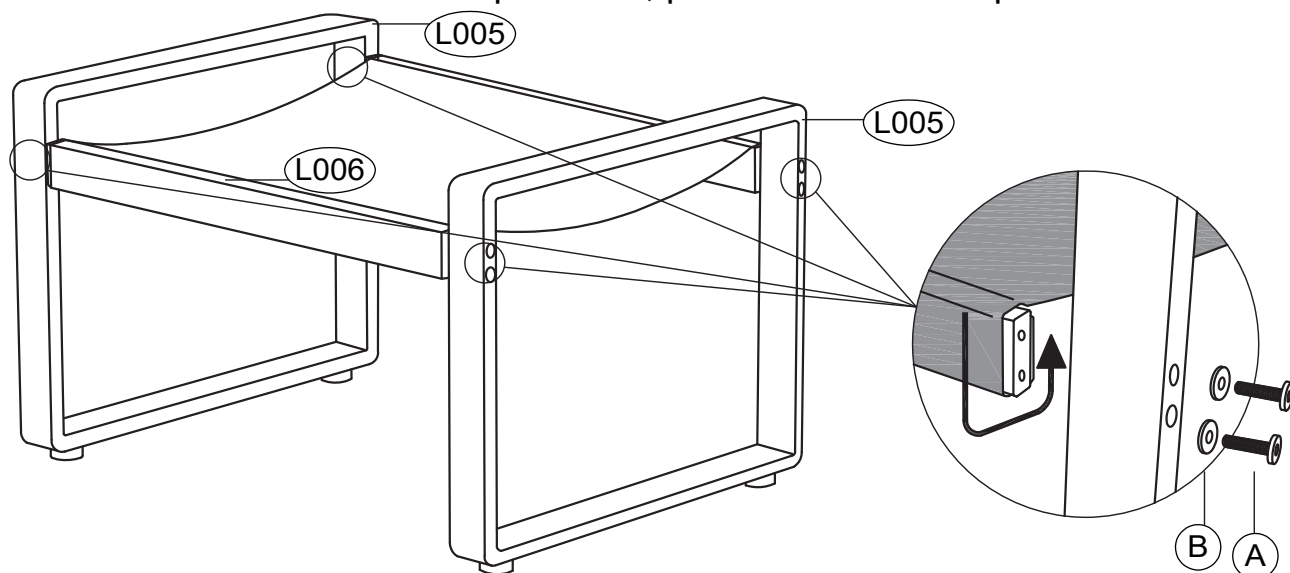
REMARQUE : Enroulez le tissu Teslin une fois autour de la tige de support métallique avant de le fixer aux pieds du repose-pieds.

Fixez d'abord les quatre vis, puis serrez-les complètement.



| | | | | | | | | | | | | | | |
|------|---|----|------|---|----|---|---|----|---|---|----|---|---|----|
| L005 |  | x2 | L006 |  | x1 | A |  | x8 | B |  | x8 | C |  | x1 |
|------|---|----|------|---|----|---|---|----|---|---|----|---|---|----|

ÉTAPE 02 : Placez le coussin sur la surface du siège en Teslin pour terminer l'assemblage.

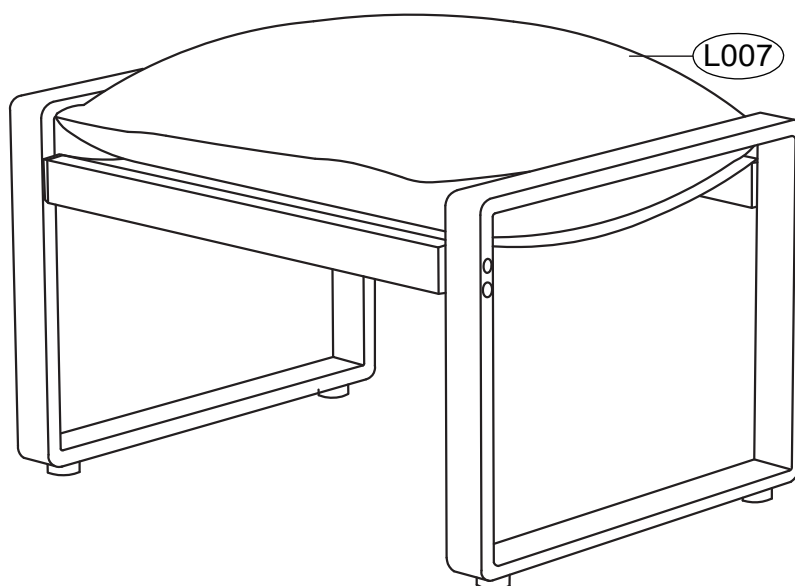





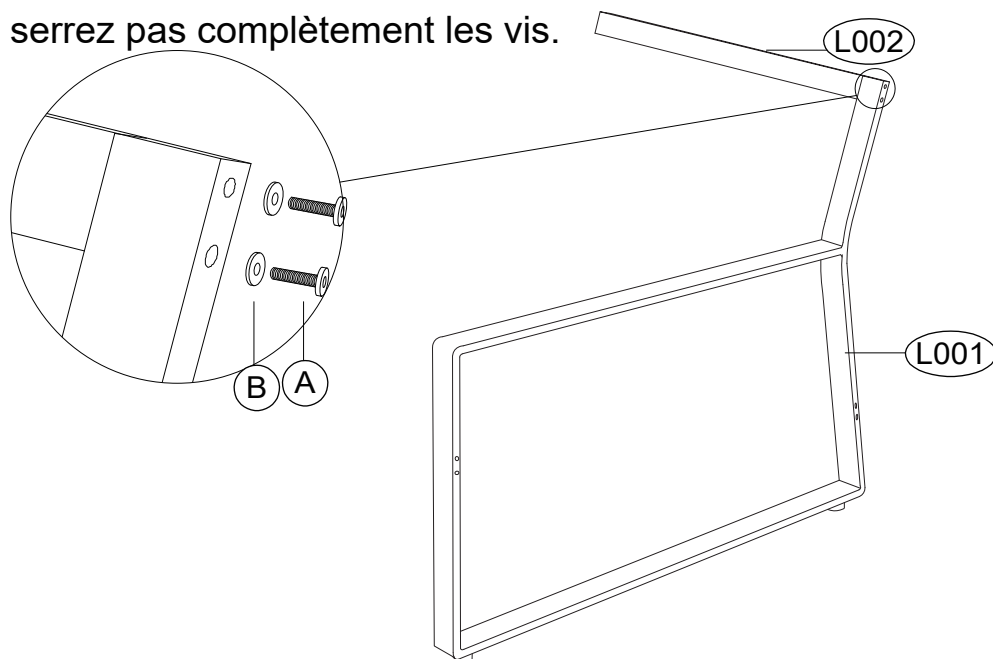

| | | |
|------|---|----|
| L007 |  | x1 |
|------|---|----|

How To Assemble The Chair

ÉTAPE 01 : Fixez l'accoudoir (L001) à la tige de support centrale (L002) à l'aide de vis.

REMARQUE : Ne serrez pas complètement les vis.





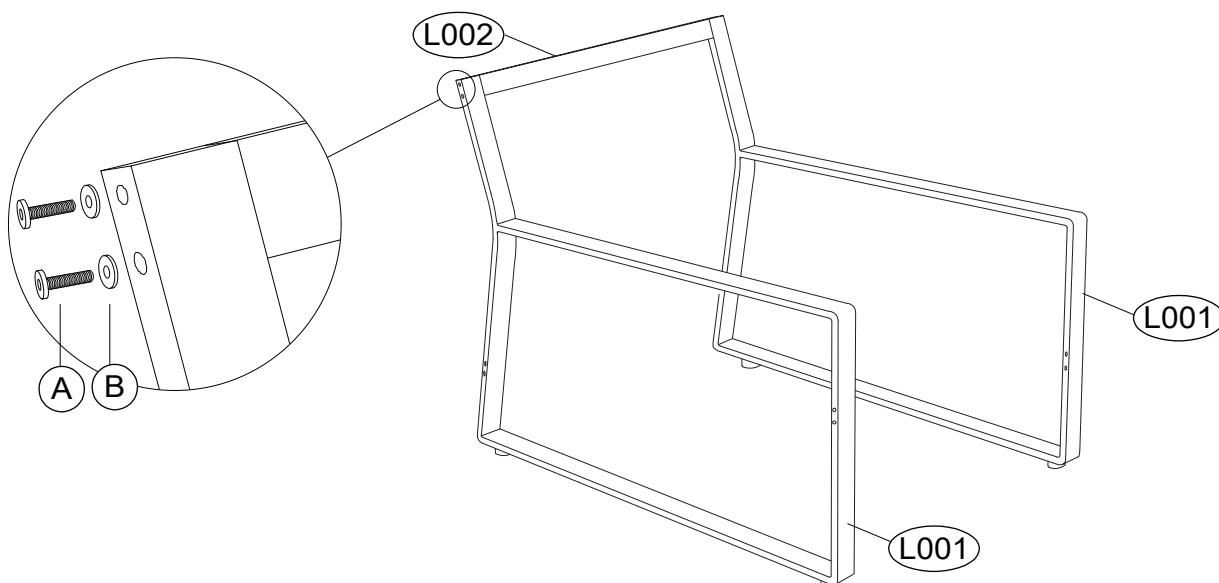

| | | | | | | | | | | | | | | |
|------|---|----|------|---|----|---|---|----|---|---|----|---|---|----|
| L001 |  | x1 | L002 |  | x1 | A |  | x2 | B |  | x2 | C |  | x1 |
|------|---|----|------|---|----|---|---|----|---|---|----|---|---|----|

ÉTAPE 02 : Fixez l'autre tige de support centrale (L002) à l'aide de vis pour assembler les deux accoudoirs à l'emplacement indiqué sur le schéma.

REMARQUE : Ne serrez pas complètement les vis.



| | | | | | | | | | | | |
|------|---|----|---|---|----|---|---|----|---|---|----|
| L001 |  | x1 | A |  | x2 | B |  | x2 | C |  | x1 |
|------|---|----|---|---|----|---|---|----|---|---|----|

Étapes d'installation

ÉTAPE 03 : Fixez l'autre accoudoir (L001) au côté opposé de la tige de support centrale (L002) récemment installée à l'aide de vis.

REMARQUE : Ne serrez pas complètement les vis.

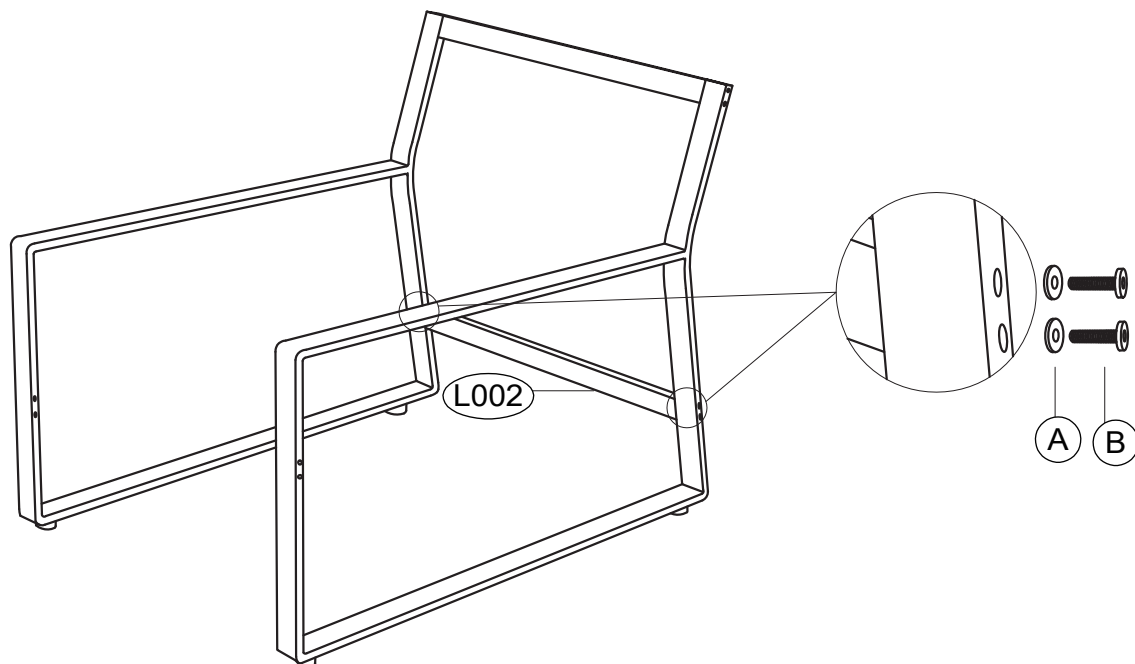

| | | | | | | | | | | | |
|------|---|----|---|---|----|---|---|----|---|---|----|
| L002 |  | x1 | A |  | x4 | B |  | x4 | C |  | x1 |
|------|---|----|---|---|----|---|---|----|---|---|----|

ÉTAPE 04 : Placez la housse de siège en tissu Teslin (L003) sur la partie appuie-tête du fauteuil.

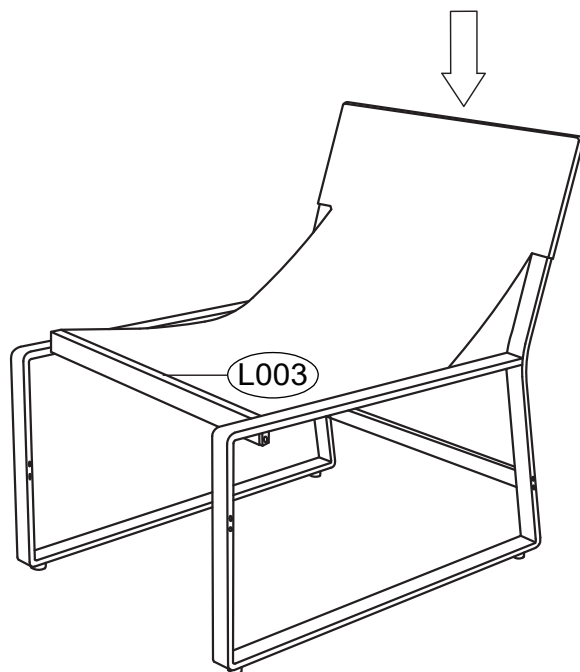

L003

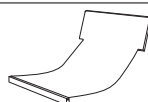

x1

Étapes d'installation

ÉTAPE 05 : Fixez les connecteurs métalliques, déjà équipés de tissu Teslin (L003), à chaque accoudoir à l'aide de vis.

REMARQUE : Assurez-vous que toutes les vis sont bien serrées.

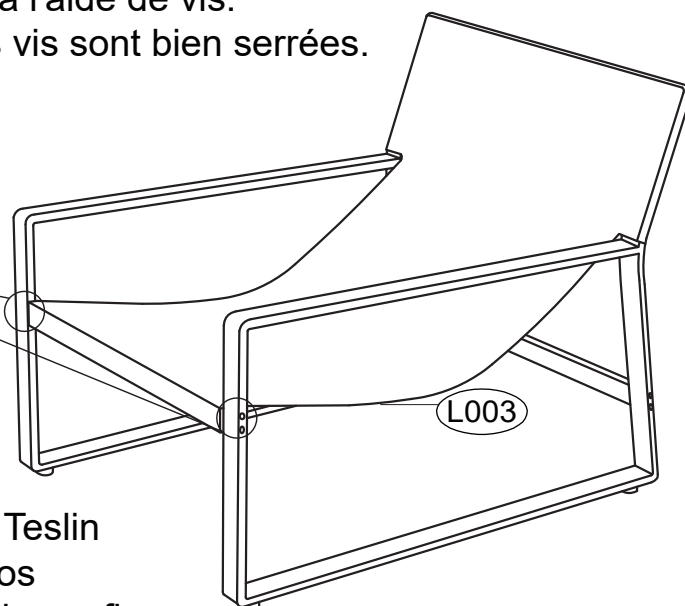
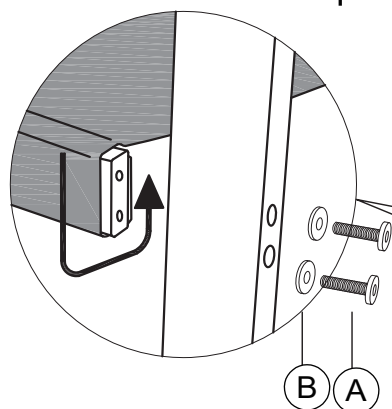

Vous pouvez enrouler plusieurs fois le tissu Teslin autour des connecteurs métalliques selon vos préférences en matière d'assise ou d'inclinaison afin de régler la hauteur minimale et l'angle d'inclinaison du fauteuil inclinable.

| | | | | | | | | | | | |
|------|--|----|---|--|----|---|--|----|---|--|----|
| L003 | | x1 | A | | x4 | B | | x4 | G | | x1 |
|------|--|----|---|--|----|---|--|----|---|--|----|

ÉTAPE 06 : Placez la housse de coussin (L004) sur le fauteuil.

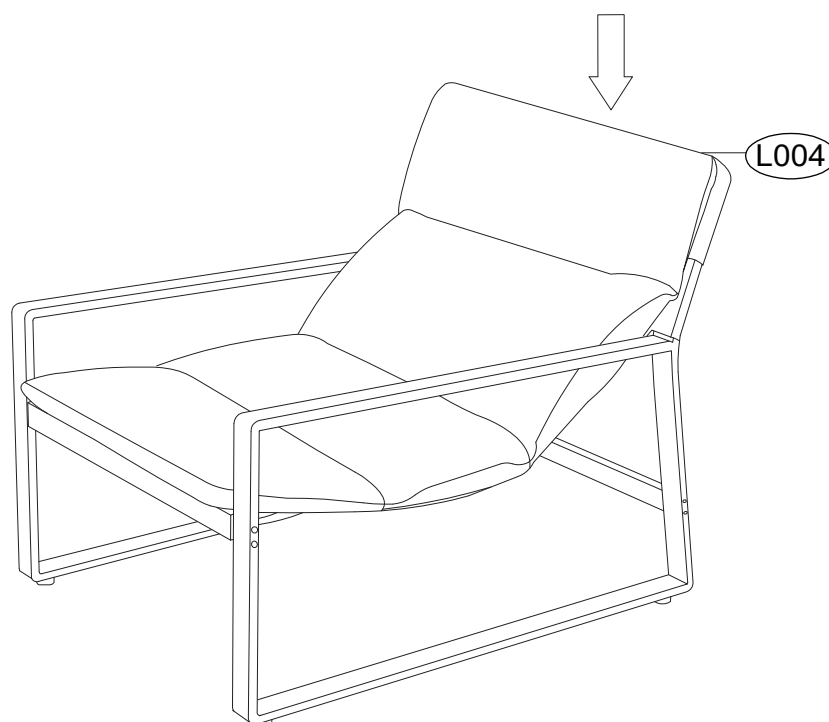

| | | |
|------|--|----|
| L004 | | x2 |
|------|--|----|

2 unidades de sillón Teslin

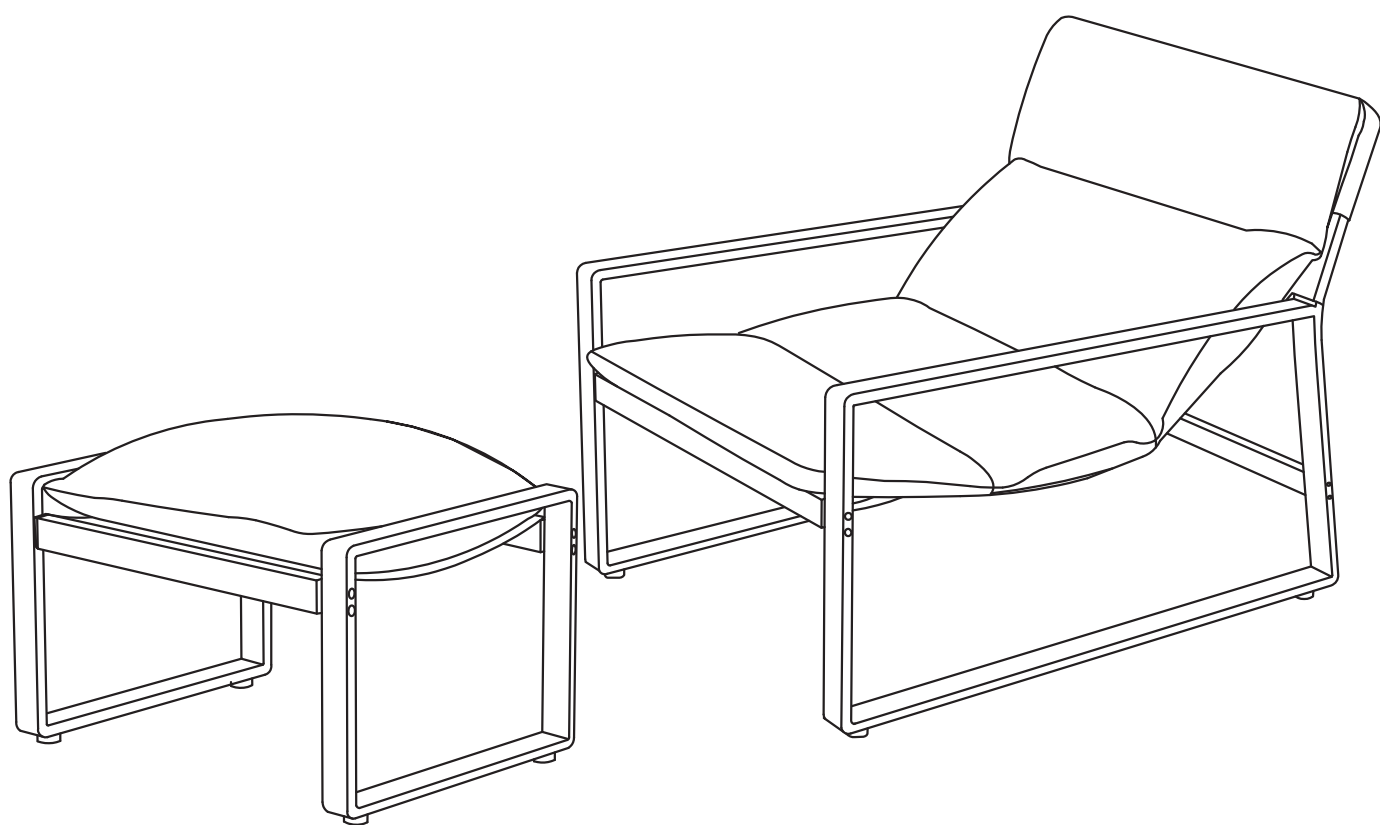

IMPORTANTE

LEA ANTES DE COMENZAR EL MONTAJE

Siga las instrucciones de esta guía del usuario para garantizar el montaje y cuidado correctos de este producto.

2 unidades de sillón Teslin

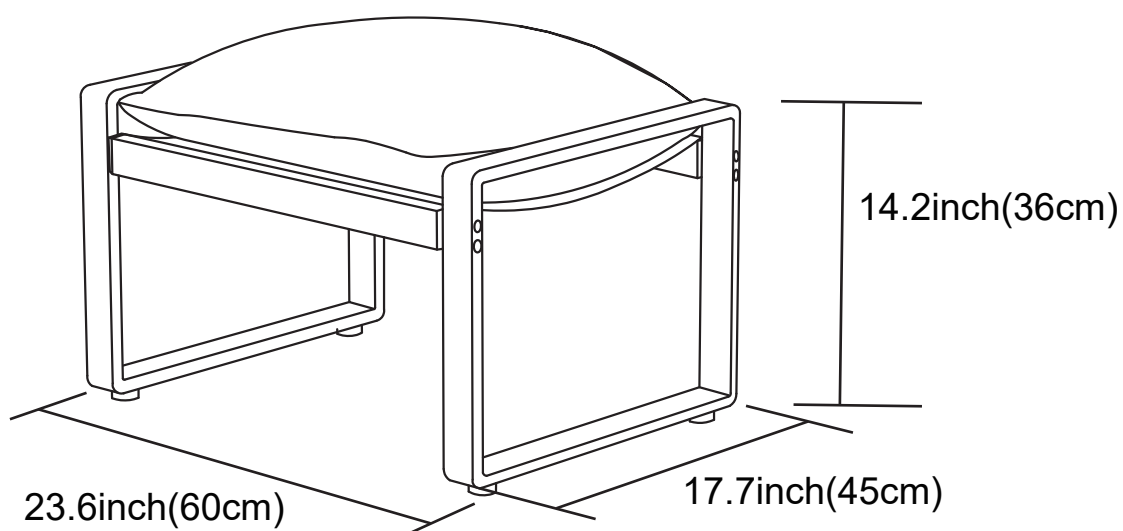
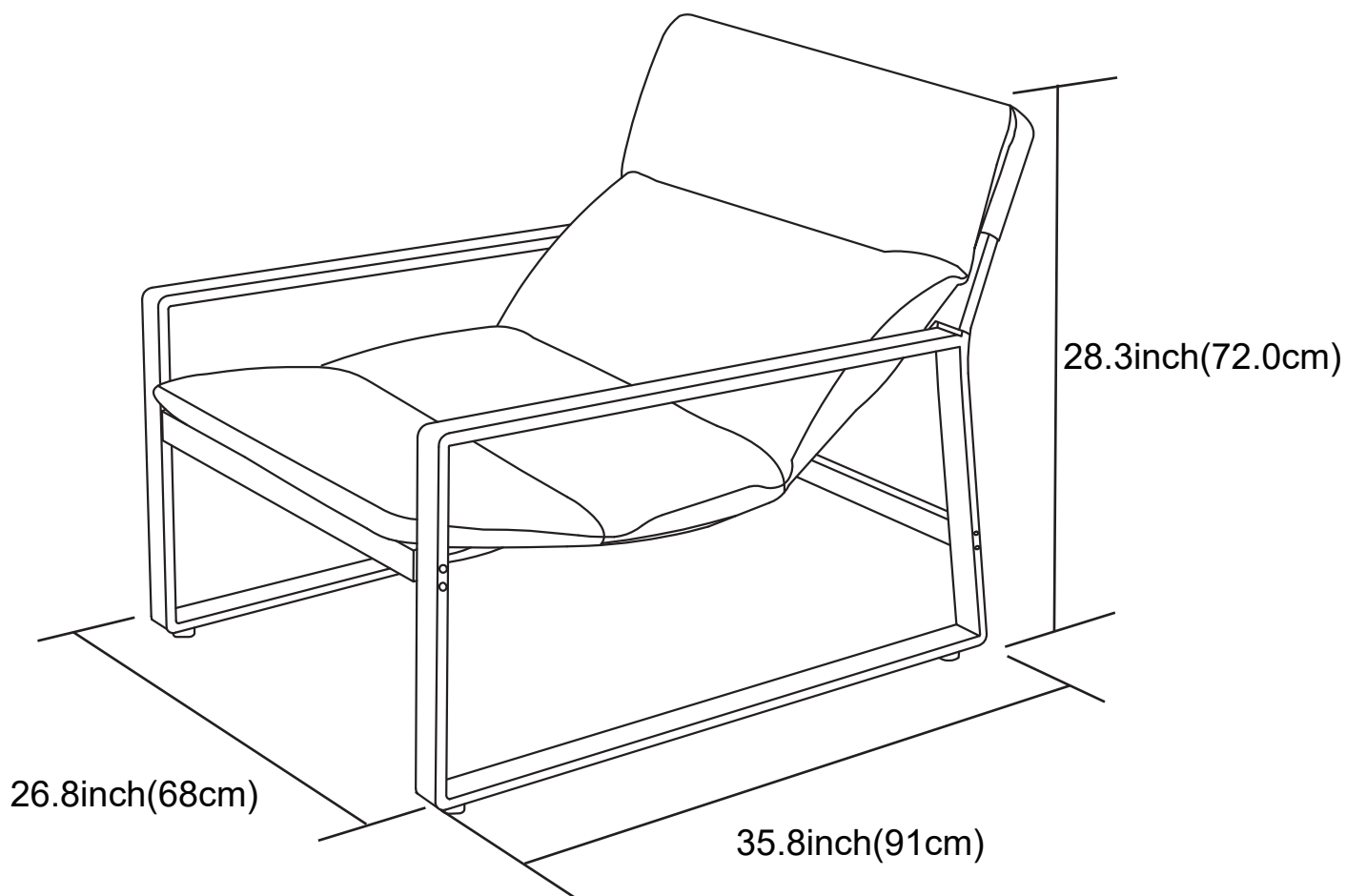

Catálogo

Especificaciones..... 01

Catálogo..... 02

Aviso..... 03

Lista de piezas y lista de tornillos..... 04

Cómo montar el reposapiés..... 05

Cómo montar la silla..... 06



Antes de comenzar



Las instrucciones se proporcionan en este manual y contienen toda la información pertinente para su producto.

Revise todas las instrucciones antes de comenzar y, durante el montaje, siga cuidadosamente la secuencia de pasos para obtener resultados correctos.

1. Todas las piezas están embaladas dentro de la caja de cartón. Separe el contenido de la caja por número de pieza mientras revisa la lista de piezas. Compruebe que tiene todas las piezas necesarias para el montaje.
2. Familiarícese con los herrajes y los elementos de fijación para facilitar su uso durante el montaje.
3. Los primeros pasos muestran cómo unir las piezas relacionadas para obtener subconjuntos más grandes que se utilizarán más adelante.
4. Tenga en cuenta que se han suministrado sujetadores adicionales para su comodidad.
5. Si dispone de un destornillador eléctrico, puede utilizarlo en lugar del destornillador que le proporcionamos. Un destornillador eléctrico puede ayudarle a reducir el tiempo de montaje.

LISTA DE PIEZAS

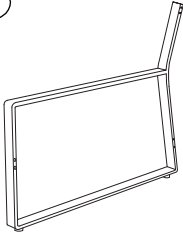
Lista de piezas

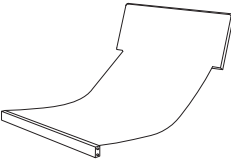
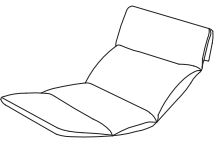
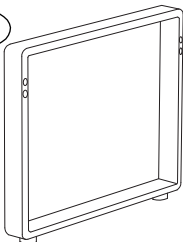
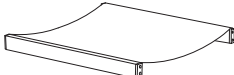
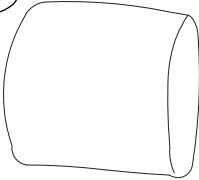
| | | | |
|---|---|--|---|
| <p>L001</p>  | <p>L002</p>  | <p>L003</p>  | <p>L004</p>  |
| <p>2PCS</p> | <p>2PCS</p> | <p>1PC</p> | <p>1PC</p> |
| <p>L005</p>  | <p>L006</p>  | <p>L007</p>  | |
| <p>2PCS</p> | <p>1PC</p> | <p>1PC</p> | |

Juego de tornillos

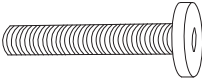
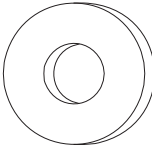
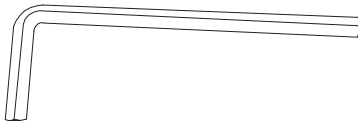
| | | |
|---|--|---|
| <p>A</p>  <p>M6*50</p> | <p>B</p>  <p>M6</p> | <p>C</p>  <p>4*4</p> |
| <p>20PCS</p> | <p>20PCS</p> | <p>1PC</p> |

Extra (juego de tornillos)

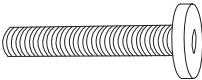
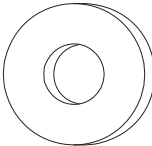
| | | |
|---|--|--|
| <p>A</p>  <p>M6*50</p> | <p>B</p>  <p>M6</p> | |
| <p>2PCS</p> | <p>2PCS</p> | |





Cómo montar el reposapiés

PASO 01: Fije el asiento de Teslin a las dos patas del reposapiés con tornillos.

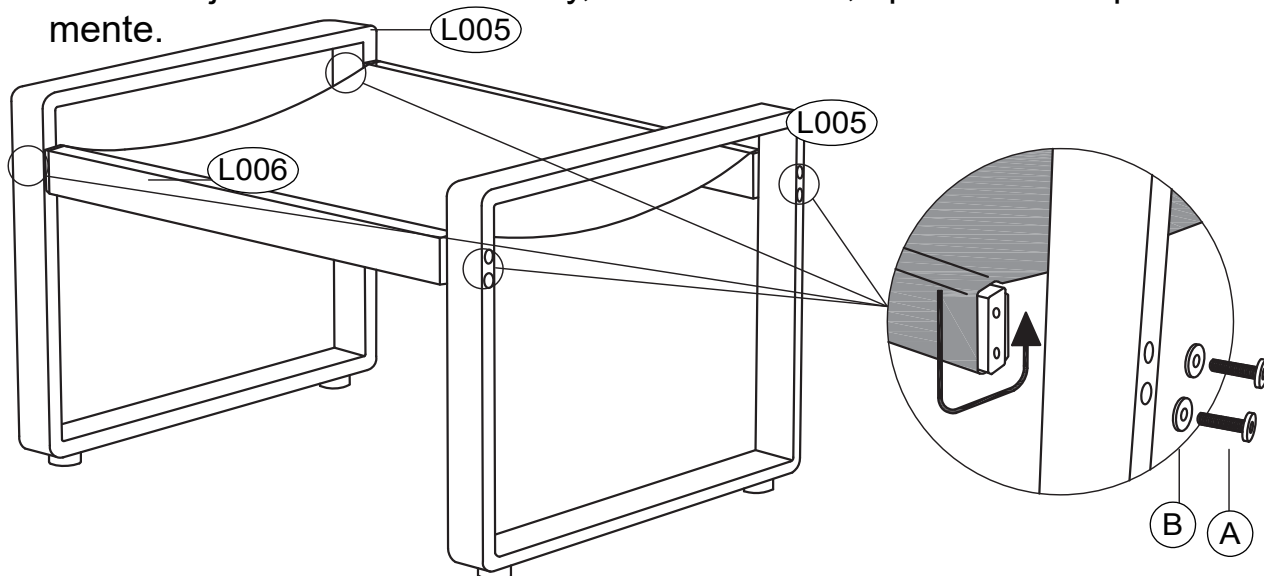
NOTA: Enrolle la tela de Teslin una vez alrededor de la barra de soporte metálica antes de fijarla a las patas del reposapiés.

Primero fije los cuatro tornillos y, a continuación, apriételos completamente.



| | | | | | | | | | | | | | | |
|------|---|----|------|---|----|---|---|----|---|---|----|---|---|----|
| L005 |  | x2 | L006 |  | x1 | A |  | x8 | B |  | x8 | C |  | x1 |
|------|---|----|------|---|----|---|---|----|---|---|----|---|---|----|

PASO 02: Coloque el cojín sobre la superficie del asiento Teslin para completar el montaje.

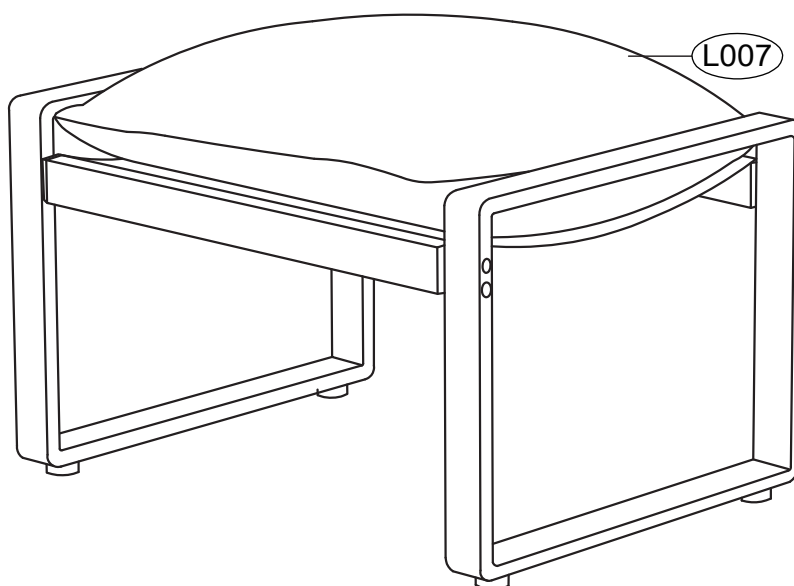





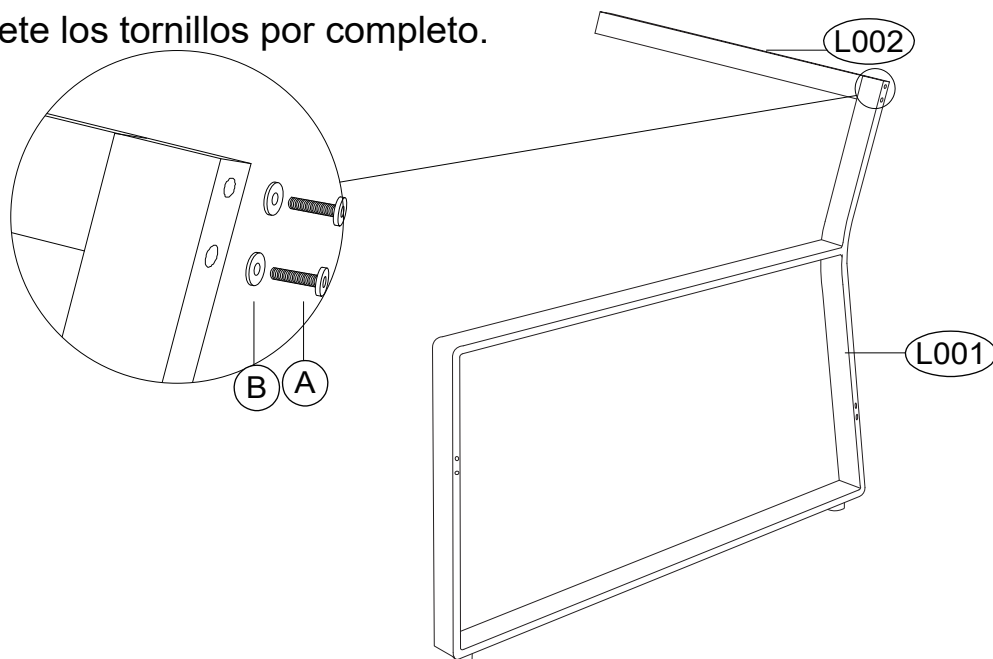

| | | |
|------|---|----|
| L007 |  | x1 |
|------|---|----|

Cómo montar la silla

PASO 01: Fije el reposabrazos (L001) a la barra de soporte central (L002) con tornillos.

NOTA: No apriete los tornillos por completo.





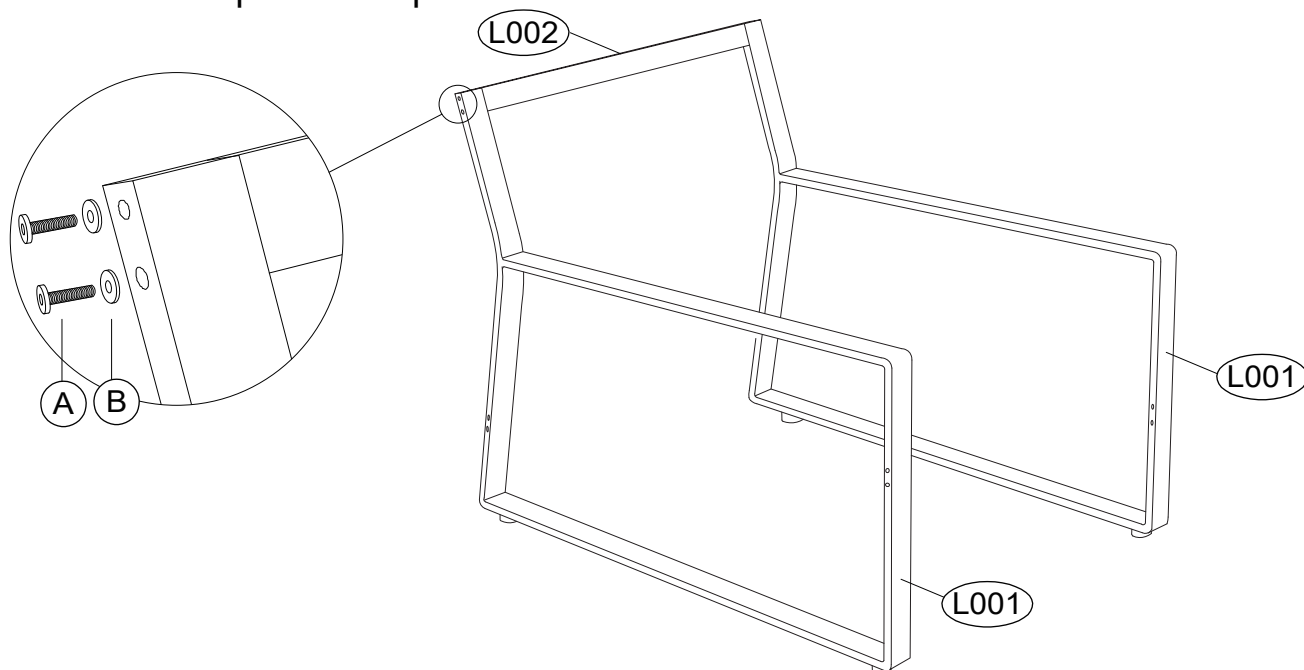

| | | | | | | | | | | | | | | |
|------|---|----|------|---|----|---|---|----|---|---|----|---|---|----|
| L001 |  | x1 | L002 |  | x1 | A |  | x2 | B |  | x2 | C |  | x1 |
|------|---|----|------|---|----|---|---|----|---|---|----|---|---|----|

PASO 02: Fije la otra barra de soporte central (L002) con tornillos para unir los dos reposabrazos en la posición que se muestra en el diagrama.

NOTA: No apriete completamente los tornillos.



| | | | | | | | | | | | |
|------|---|----|---|---|----|---|---|----|---|---|----|
| L001 |  | x1 | A |  | x2 | B |  | x2 | C |  | x1 |
|------|---|----|---|---|----|---|---|----|---|---|----|

Pasos de instalación

PASO 03: Fije el otro reposabrazos (L001) al lado opuesto de la barra de soporte central (L002) recién instalada utilizando tornillos.

NOTA: No apriete los tornillos completamente.

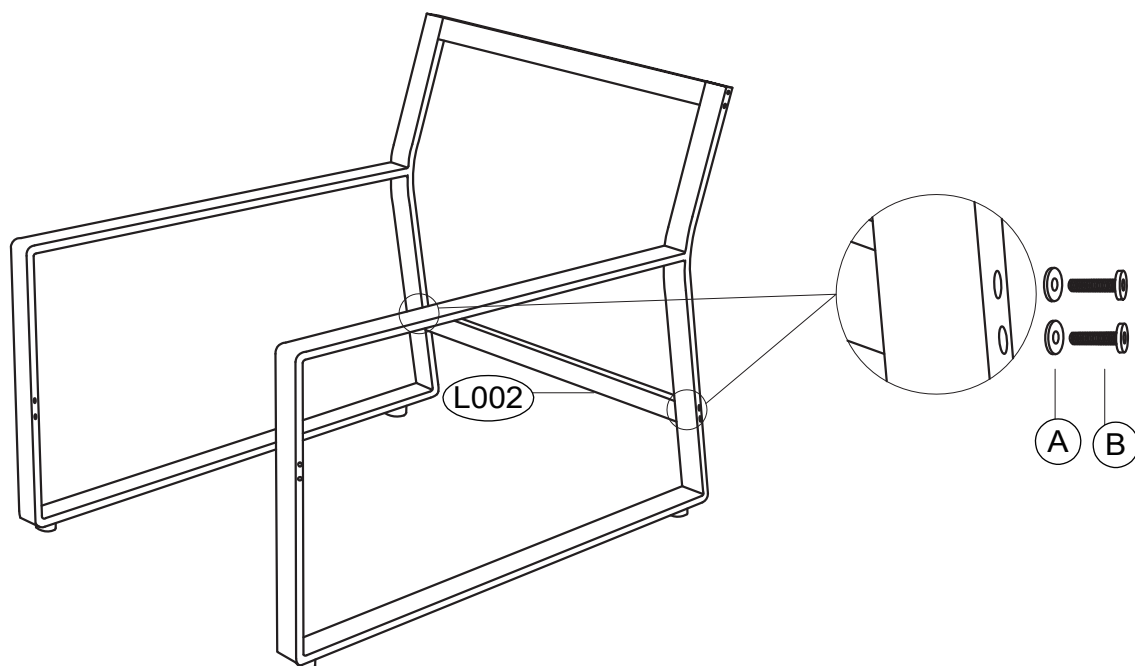

L002 x1 A x4 B x4 C x1

PASO 04: Coloque la funda de tela Teslin (L003) sobre la sección del reposacabezas del sillón.

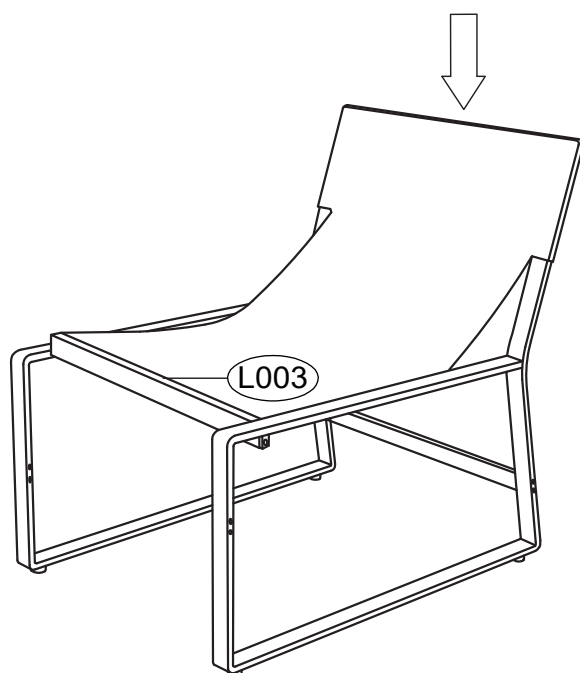

L003

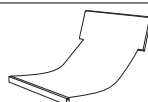

x1



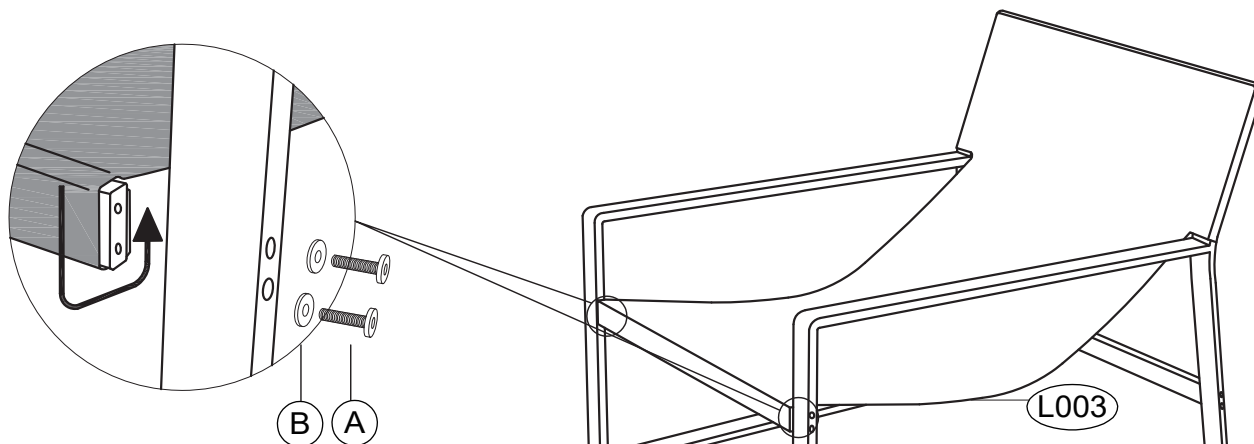

Pasos de instalación

PASO 05: Fije los conectores metálicos, ya equipados con tejido Teslin (L003), a cada reposabrazos con tornillos.

NOTA: Asegúrese de que todos los tornillos estén bien apretados.



Puede enrollar la tela Teslin varias veces alrededor de los conectores metálicos según sus preferencias de posición sentada o reclinada para ajustar la altura mínima y el ángulo de reclinación del sillón reclinable.

| | | | | | | | | | | | |
|------|---|----|---|---|----|---|---|----|---|---|----|
| L003 |  | x1 | A |  | x4 | B |  | x4 | G |  | x1 |
|------|---|----|---|---|----|---|---|----|---|---|----|

PASO 06: Coloque la funda de cojín (L004) sobre el sillón.

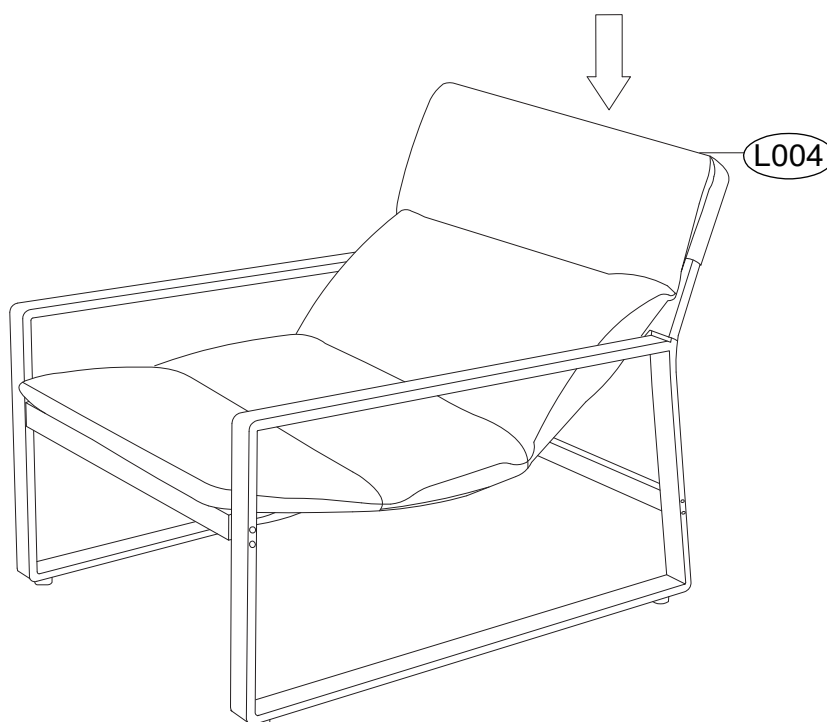

| | | |
|------|---|----|
| L004 |  | x2 |
|------|---|----|

2 pezzi Poltrona Teslin

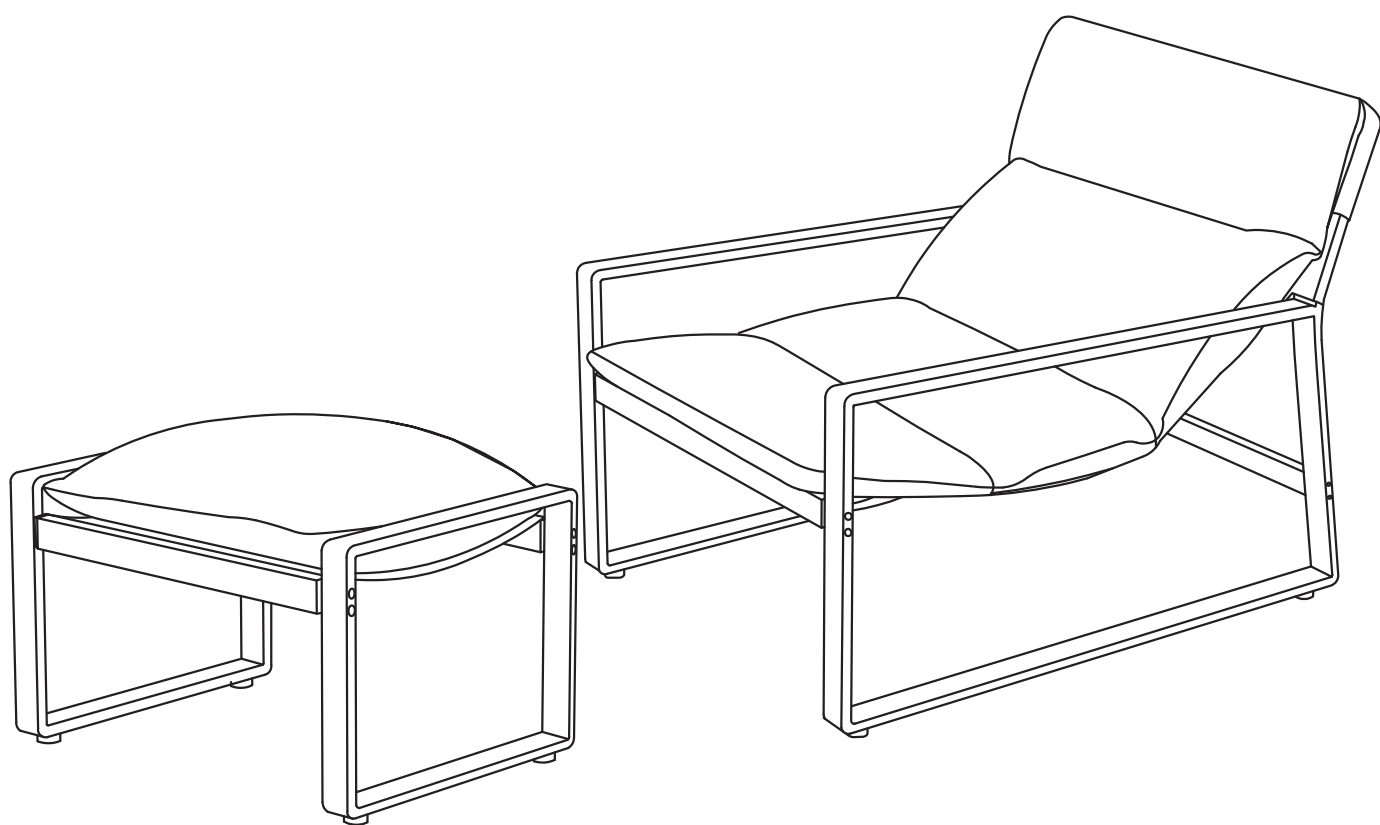

IMPORTANTE

LEGGERE PRIMA DI INIZIARE IL MONTAGGIO

Seguire le istruzioni contenute nel presente manuale d'uso per garantire il corretto montaggio e la corretta manutenzione del prodotto.

2 pezzi Poltrona Teslin

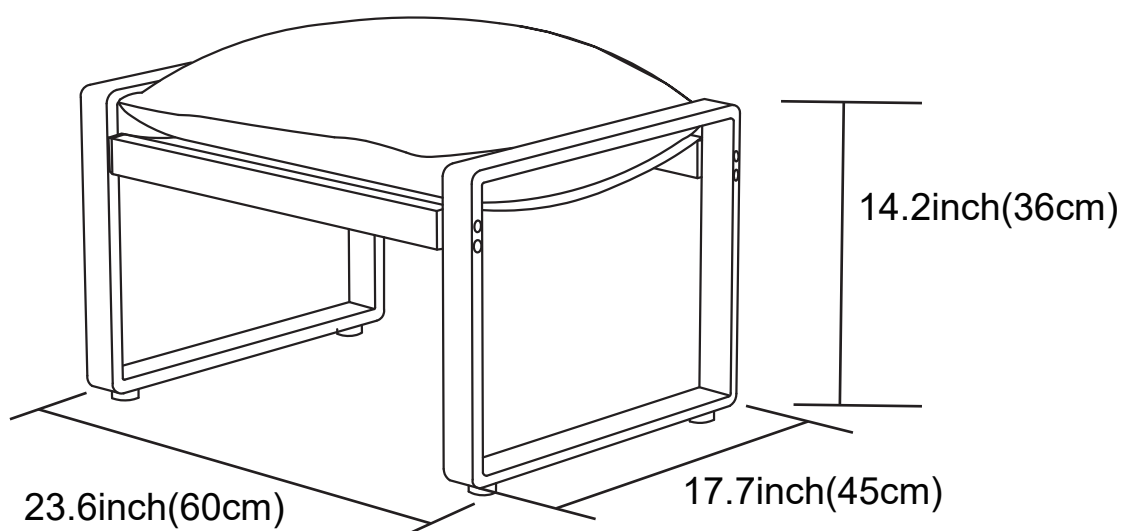
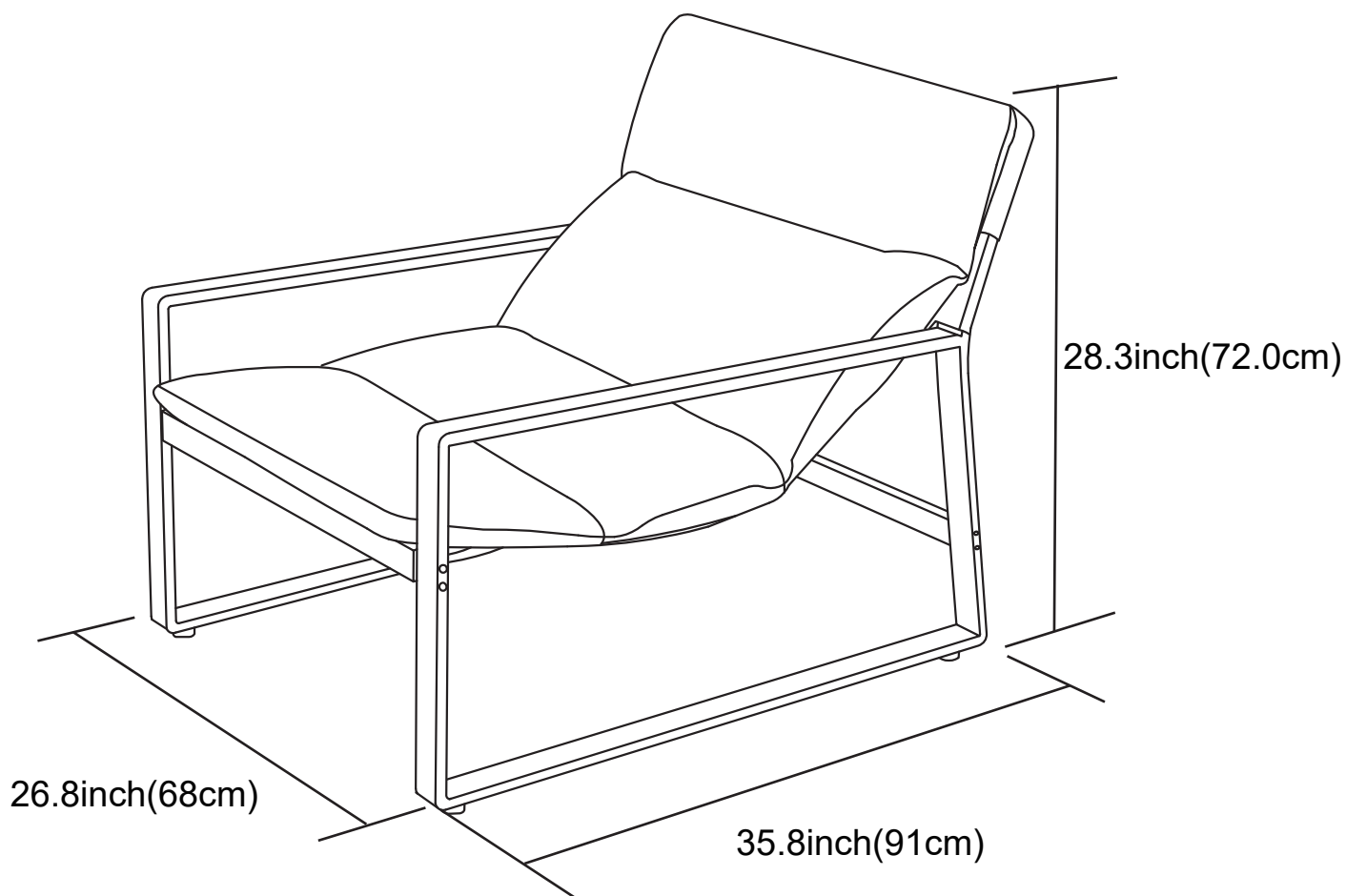

Catalogo

| | |
|---|----|
| Specifiche..... | 01 |
| Catalogo..... | 02 |
| Avviso..... | 03 |
| Elenco dei componenti e delle viti..... | 04 |
| Come assemblare il poggiapiedi..... | 05 |
| Come assemblare la sedia..... | 06 |



Prima di iniziare

Le istruzioni sono fornite in questo manuale e contengono tutte le informazioni necessarie per il vostro prodotto.

Leggete tutte le istruzioni prima di iniziare e durante il montaggio seguite attentamente la sequenza dei passaggi per ottenere risultati corretti.

1. Tutti i componenti sono contenuti all'interno del cartone. Separare il contenuto del cartone in base al numero di serie, controllando l'elenco dei componenti. Verificare di avere tutti i componenti necessari per il montaggio.
2. Familiarizzare con la ferramenta e i dispositivi di fissaggio per facilitarne l'uso durante il montaggio.
3. I primi passaggi mostrano come unire i componenti correlati per ottenere sottogruppi più grandi da utilizzare in seguito.
4. Si noti che sono stati forniti elementi di fissaggio aggiuntivi per comodità.
5. Se si dispone di un cacciavite elettrico, è possibile utilizzarlo al posto del cacciavite in dotazione. Un cacciavite elettrico può aiutare a ridurre i tempi di assemblaggio.

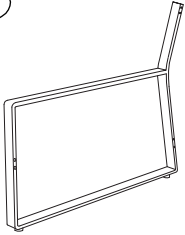
Elenco dei componenti

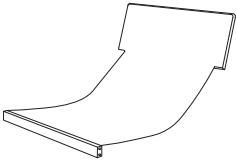
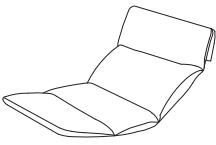
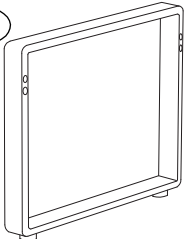
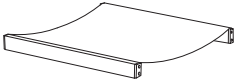
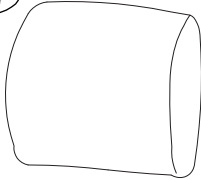
| | | | |
|---|---|--|---|
| <p>L001</p>  | <p>L002</p>  | <p>L003</p>  | <p>L004</p>  |
| <p>2PCS</p> | <p>2PCS</p> | <p>1PC</p> | <p>1PC</p> |
| <p>L005</p>  | <p>L006</p>  | <p>L007</p>  | |
| <p>2PCS</p> | <p>1PC</p> | <p>1PC</p> | |

Set di viti

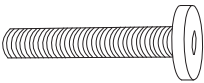
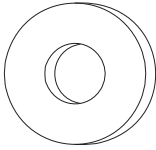
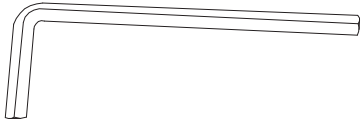
| | | |
|---|--|---|
| <p>A</p>  <p>M6*50</p> | <p>B</p>  <p>M6</p> | <p>C</p>  <p>4*4</p> |
| <p>20PCS</p> | <p>20PCS</p> | <p>1PC</p> |

Extra (set di viti)

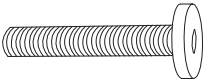
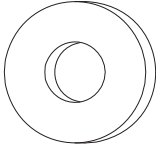
| | | |
|---|--|--|
| <p>A</p>  <p>M6*50</p> | <p>B</p>  <p>M6</p> | |
| <p>2PCS</p> | <p>2PCS</p> | |





Come montare il poggiatesta

FASE 01: Fissare il sedile in Teslin alle due gambe del poggiatesta utilizzando delle
NOTA: viti.

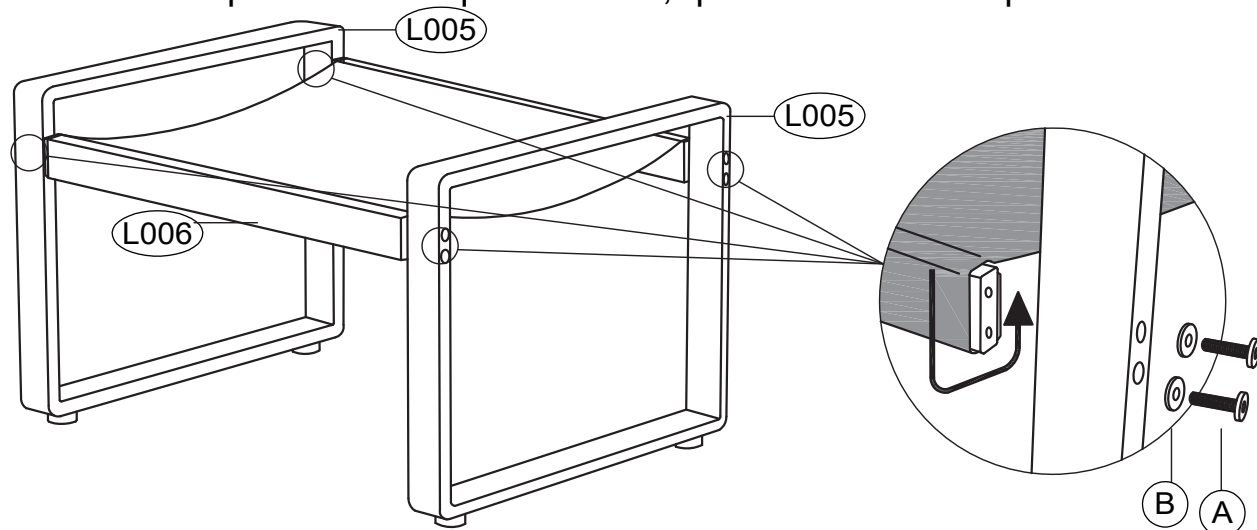
Avvolgere il tessuto Teslin attorno all'asta di supporto metallica una volta prima di fissarlo alle gambe del poggiatesta.

Fissare prima tutte e quattro le viti, quindi serrarle completamente.



| | | | | | | | | | | | | | | |
|------|---|----|------|---|----|---|---|----|---|---|----|---|---|----|
| L005 |  | x2 | L006 |  | x1 | A |  | x8 | B |  | x8 | C |  | x1 |
|------|---|----|------|---|----|---|---|----|---|---|----|---|---|----|

FASE 02: Posizionare il cuscino sulla superficie del sedile Teslin per completare il montaggio.

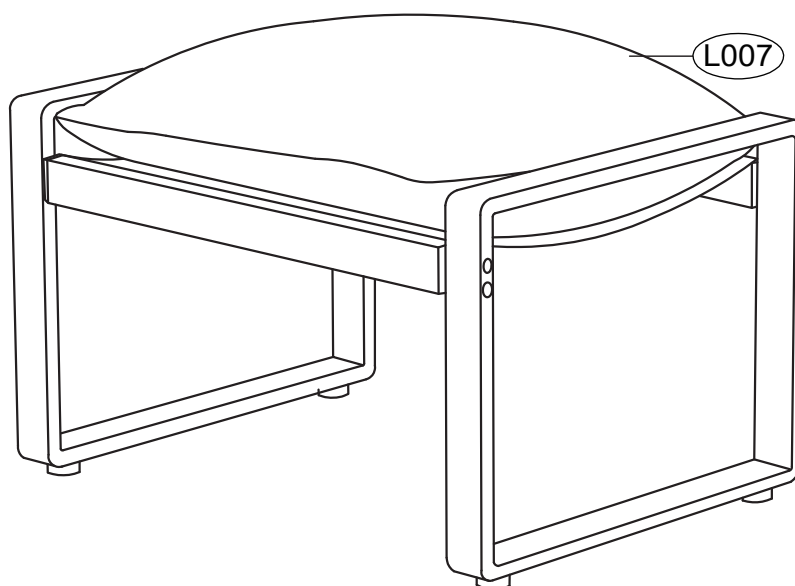





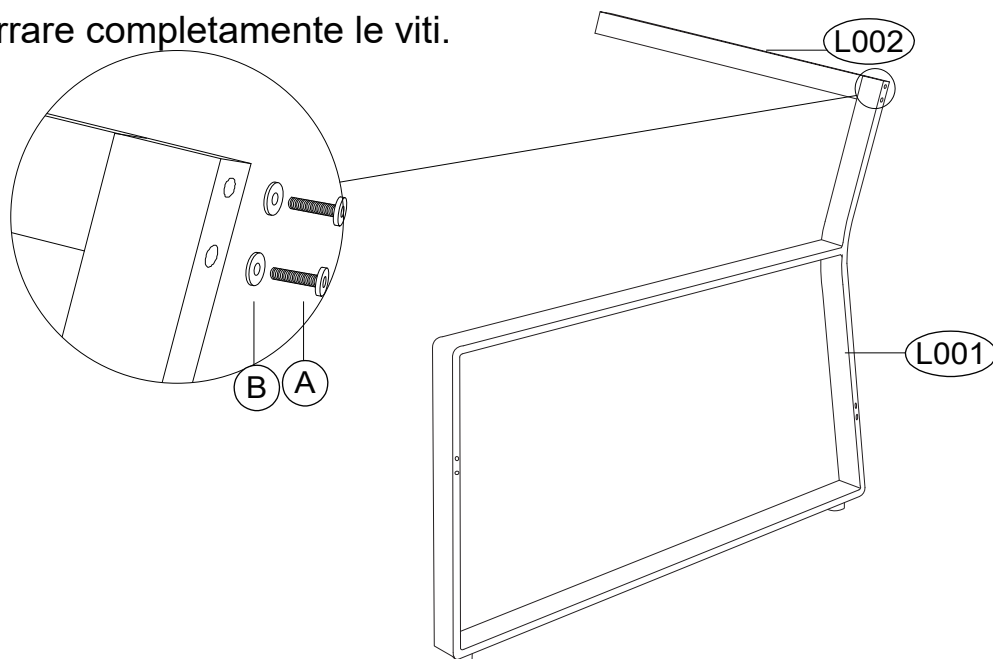

| | | |
|------|---|----|
| L007 |  | x1 |
|------|---|----|

Come assemblare la sedia

FASE 01: Fissare il bracciolo (L001) all'asta di supporto centrale (L002) utilizzando le viti.

NOTA: Non serrare completamente le viti.





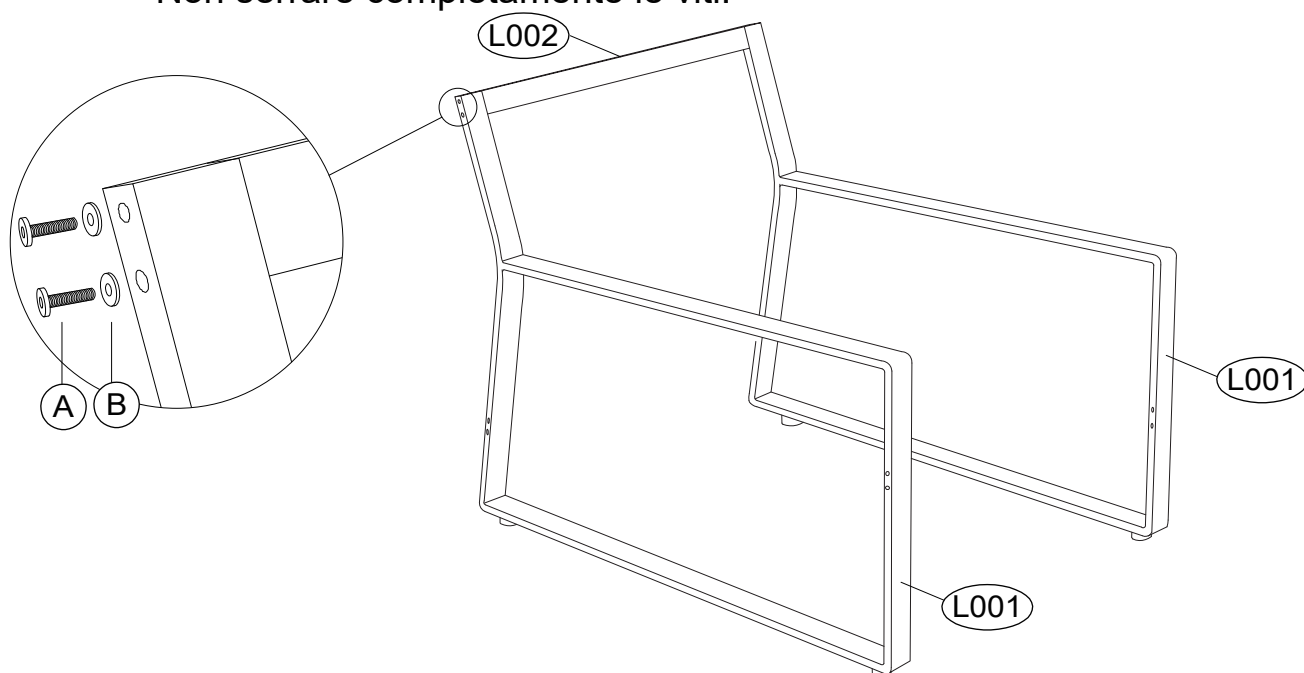

| | | | | | | | | | | | | | | |
|------|---|----|------|---|----|---|---|----|---|---|----|---|---|----|
| L001 |  | x1 | L002 |  | x1 | A |  | x2 | B |  | x2 | C |  | x1 |
|------|---|----|------|---|----|---|---|----|---|---|----|---|---|----|

FASE 02: Fissare l'altra asta di supporto centrale (L002) con le viti per unire i due braccioli nella posizione indicata nel diagramma.

NOTA: Non serrare completamente le viti.





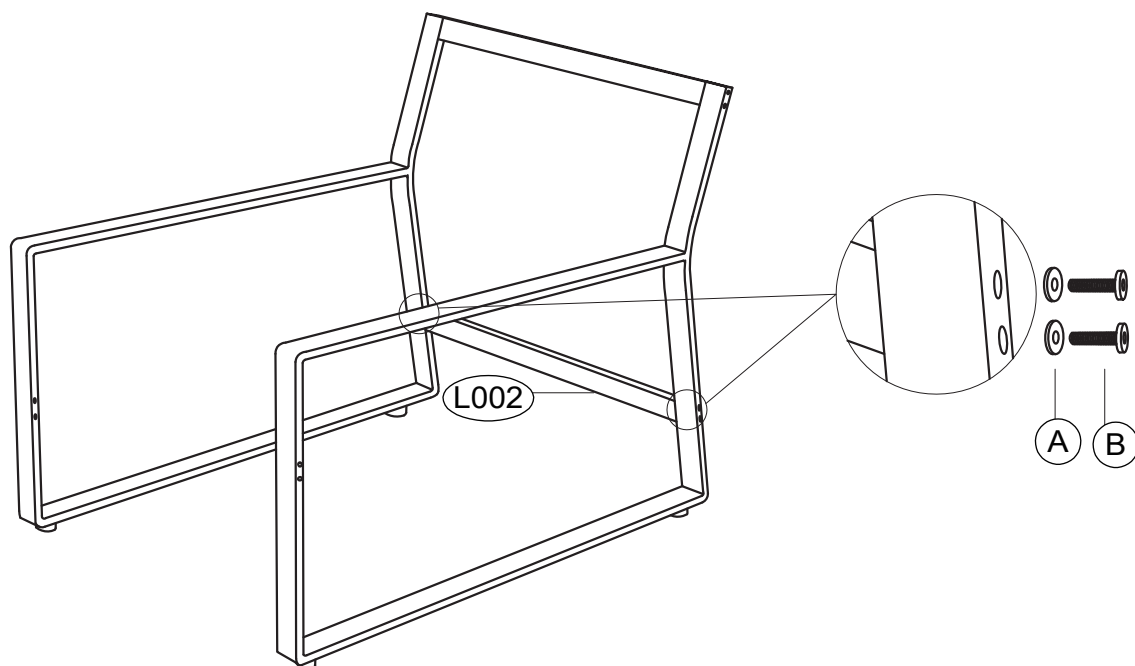

| | | | | | | | | | | | |
|------|---|----|---|---|----|---|---|----|---|---|----|
| L001 |  | x1 | A |  | x2 | B |  | x2 | C |  | x1 |
|------|---|----|---|---|----|---|---|----|---|---|----|

FASE 03: Fissare l'altro bracciolo (L001) al lato opposto dell'asta di supporto centrale (L002) appena installata utilizzando le viti.

NOTA: Non serrare completamente le viti.



| | | | | | | | | | | | |
|------|---|----|---|---|----|---|---|----|---|---|----|
| L002 |  | x1 | A |  | x4 | B |  | x4 | C |  | x1 |
|------|---|----|---|---|----|---|---|----|---|---|----|

FASE 04: Posizionare il rivestimento in tessuto Teslin (L003) sulla sezione poggiatesta della poltrona.

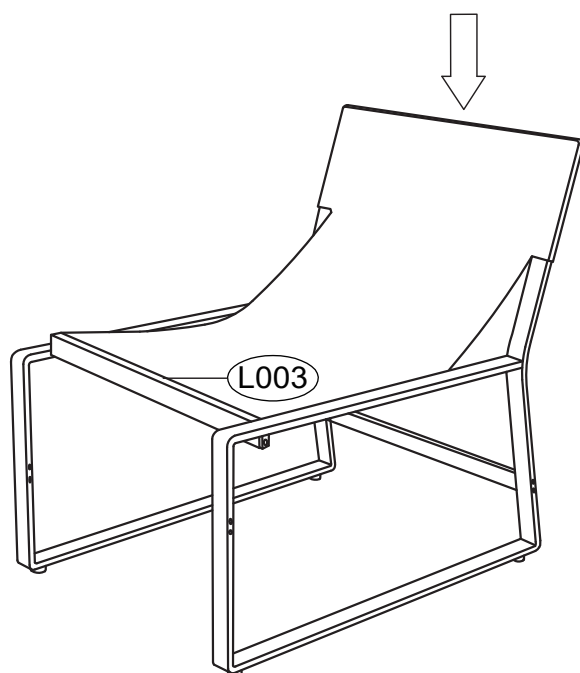

| | | |
|------|---|----|
| L003 |  | x1 |
|------|---|----|

FASE 05: Fissare i connettori metallici, già dotati di tessuto Teslin (L003), a ciascun bracciolo utilizzando le viti.

NOTA: Assicurarsi che tutte le viti siano completamente serrate.

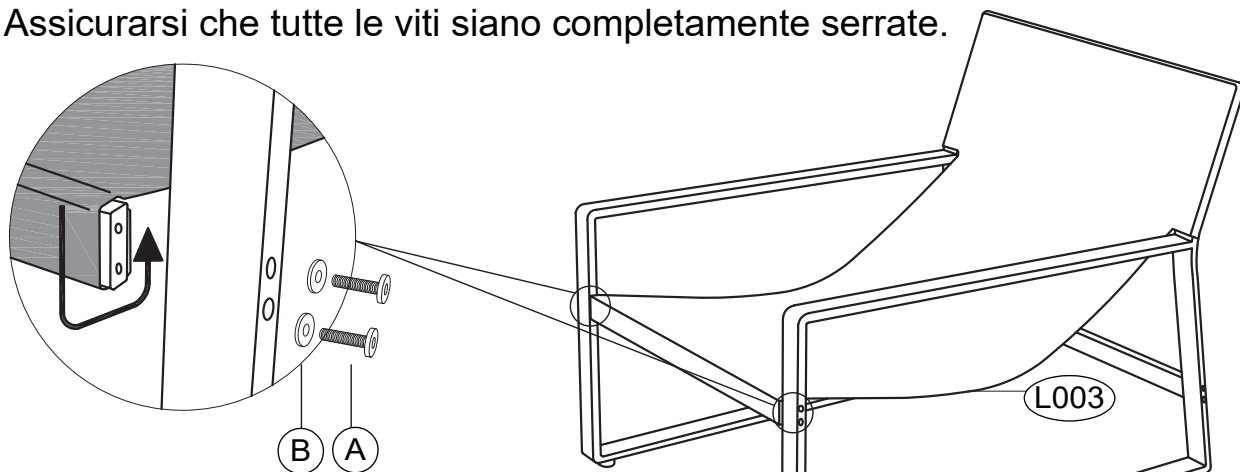

È possibile avvolgere il tessuto Teslin attorno ai connettori metallici più volte, in base alle proprie preferenze di seduta o reclinazione, per regolare l'altezza minima e l'angolo di reclinazione della poltrona reclinabile.

| | | | | | | | | | | | |
|------|--|----|---|--|----|---|--|----|---|--|----|
| L003 | | x1 | A | | x4 | B | | x4 | G | | x1 |
|------|--|----|---|--|----|---|--|----|---|--|----|

FASE 06: Posizionare il copricuscino (L004) sul divano.

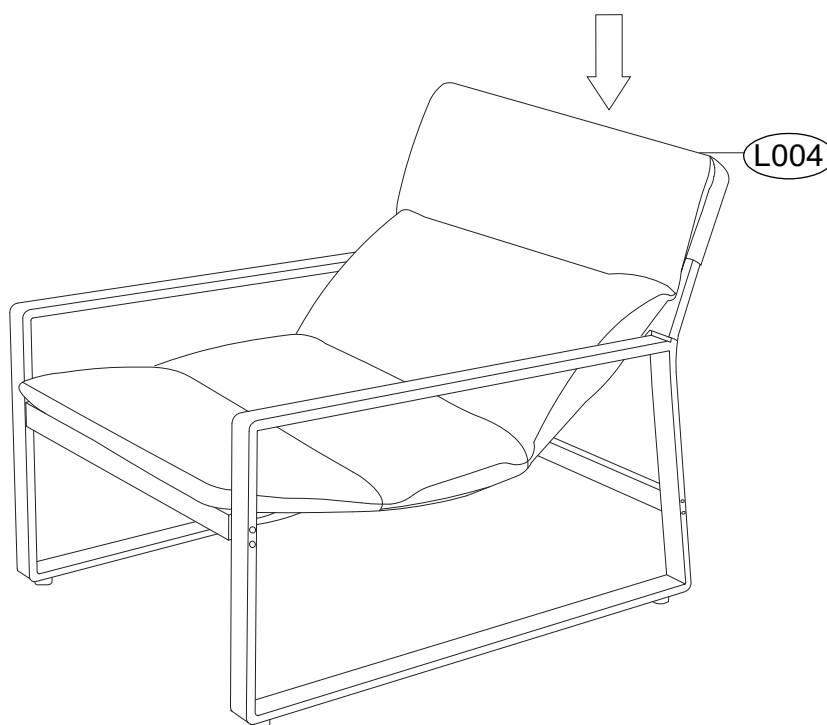

| | | |
|------|--|----|
| L004 | | x2 |
|------|--|----|