

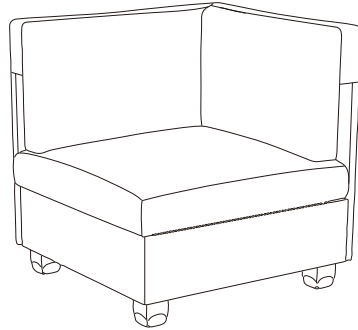

ASSEMBLY INSTRUCTION

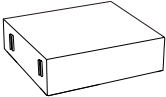
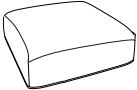
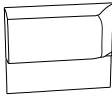
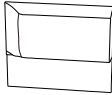

PARTS LIST

				
A x1	B x1	C x1	D x1	E x2
				
1 x4				

Open up Velcro of Non-Woven Fabric cover on the bottom of the to remove **HARDWARE** and **legs**. Please allow at least 24 hours for the cushions to recover to its natural state after removing from the package.

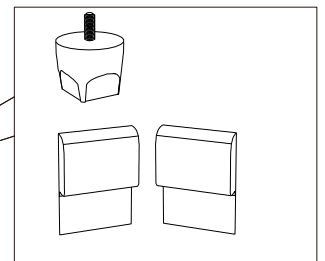
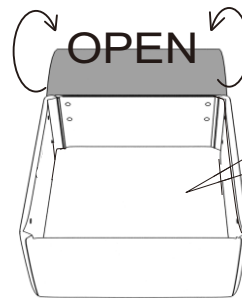

After removing the cushion from the compress bag, please allow air to flow through the cushion for few days. You can try to fluff cushion by push in and push out on all four sides of the cushion. Hitting the top/front of the cushion with your hand to fluff them after installation.

ASSEMBLY INSTRUCTION

Step1

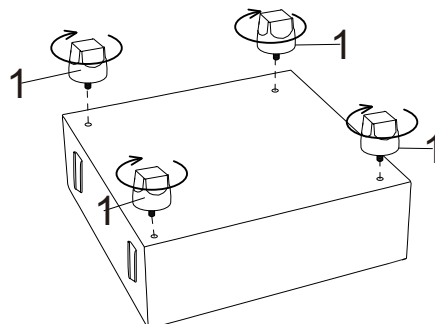

Step2

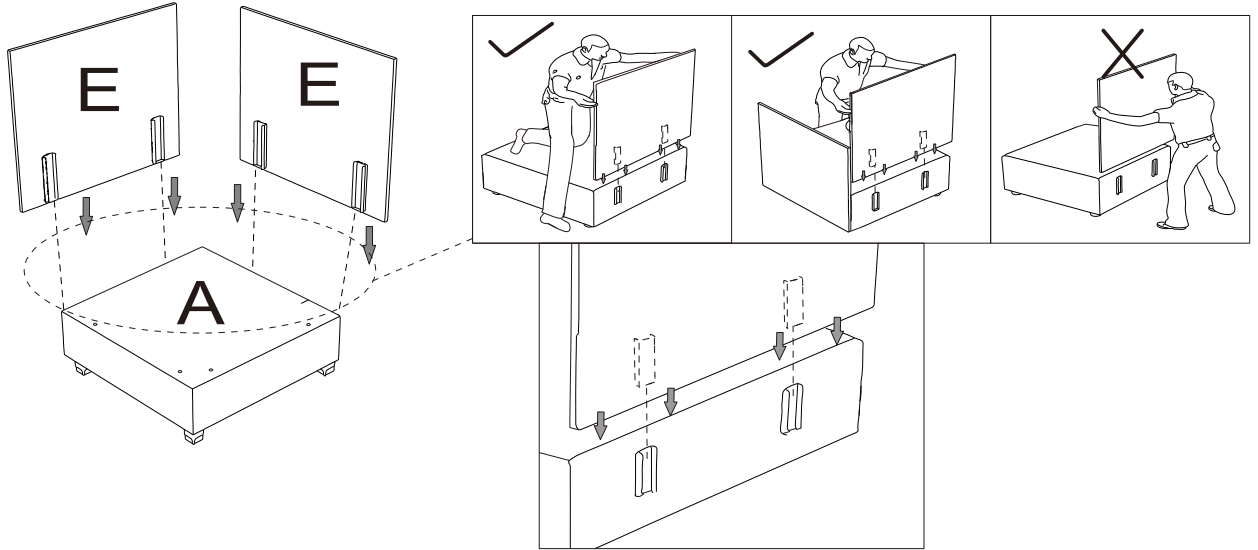

Step3

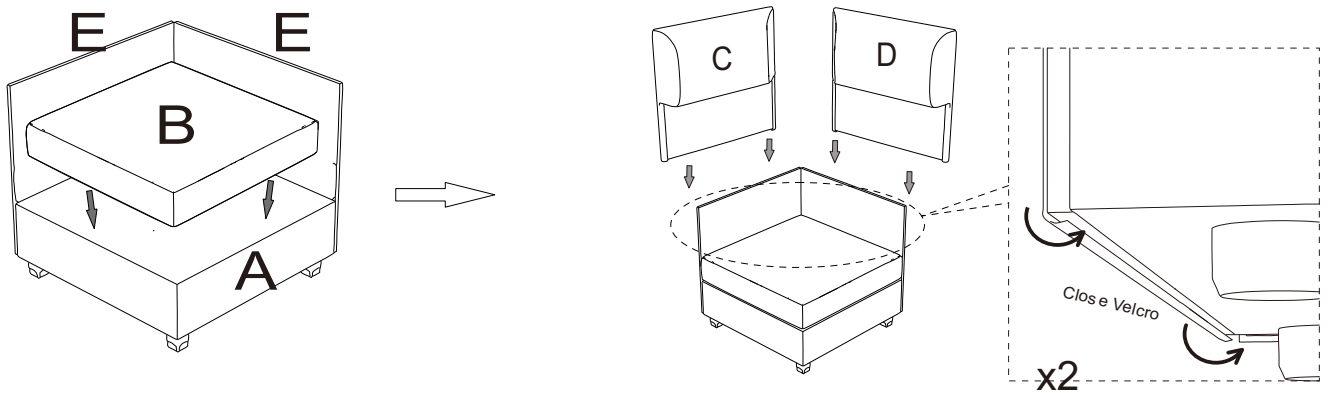

Step4

1. Located on the bottom of each pieces are wedges and clamps.

Rotate the clamps 180° so the teeth are facing outward.

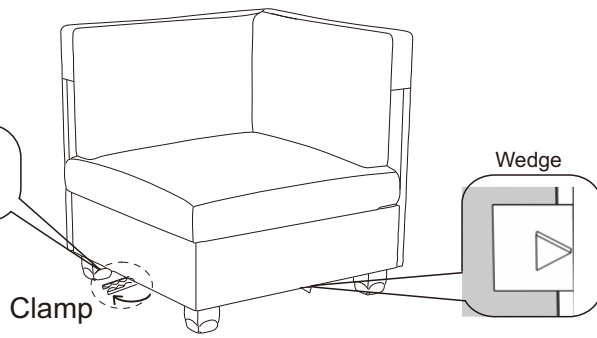

2. Slide the pieces together until the wedge engages the teeth clamp and the two pieces are snug.

Custom Modulas Sectional
Connect different pieces into
the desired configuration

