

BED FRAME

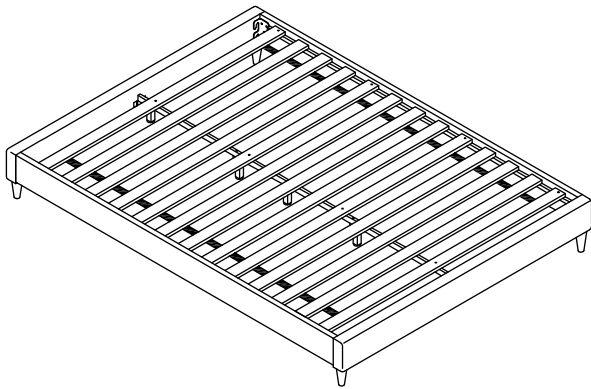

Thank you for purchasing the **FULL / QUEEN BED FRAME**

Before you start, here are some helpful advice:

1. We suggest that you spend a short time reading through this leaflet and then follow the simple step-by-step instructions.
2. Owing to the size and weight of the bed frame, we recommend that it is assembled by two adults, on a carpeted or padded area, in the room that it is intended for. Approximate assembly time: 45 minutes.
3. Please do not use any tools other than those provided or recommended in these instructions.
4. Please do not throw away any of the packaging or the instruction until you have checked all the components and hardware and the furniture is fully assembled. Please ensure that the packaging is disposed of in a safe environmentally friendly way.
5. Assemble all components loosely until advised to tighten. Depending on use, it may be necessary to tighten the components from time to time, so please save the tools that have been provided.
6. Please keep all fitting out of reach of children.



Hardware list:

- | | | | |
|---|--|-----------------|-----|
| A |  | Bolt M8 x 20mm | x8 |
| B |  | Screw M4 x 32mm | x14 |
| C |  | M5 Allen Key | x1 |

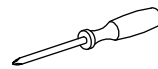

PHILLIPS HEAD SCREW DRIVER
NOT PROVIDED

Components:

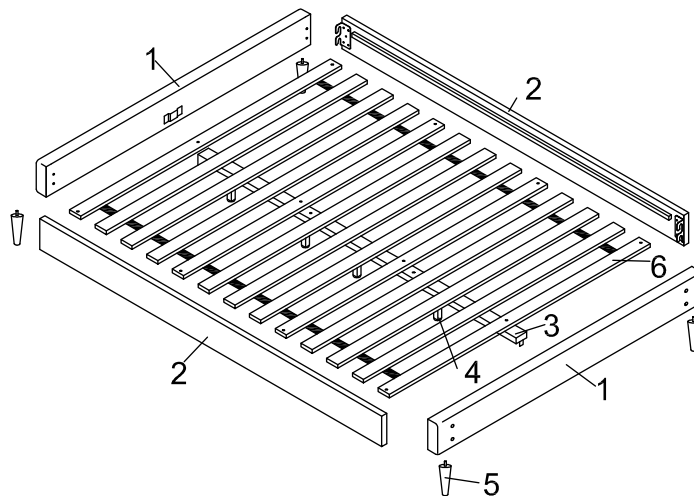

- | | | | | | |
|----------------|----|--------------|----|---------------|-----|
| 1 Short Board | x2 | 2 Long Board | x2 | 3 Center Rail | x1 |
| 4 Support Legs | x4 | 5 Legs | x4 | 6 Roll Slats | x13 |
- (Round leg or square leg)

BED FRAME

STEP 1

Secure the 2 pieces of **Wooden Leg (5)** to the **Short Board (1)** as shown. Repeat the same steps for the remaining 1 piece of **Short Board (1)**. Tighten the **Leg (5)** clockwise until secure.

Attention: If it is square leg, please make sure the leg direction is level with frame.

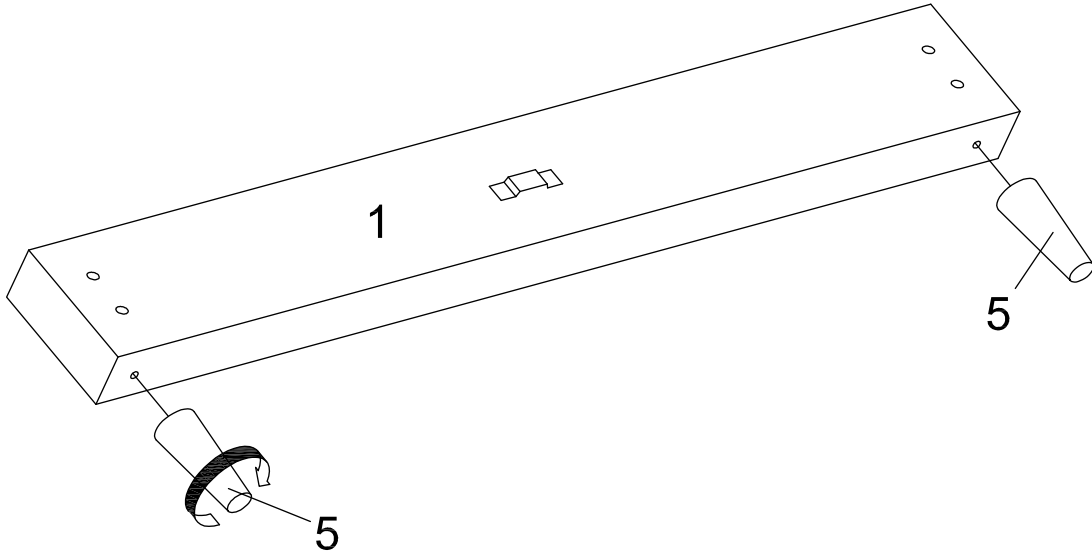

STEP 2

Place 1 piece of **Long Board (2)** to the assembled 2 pieces **Short Board (1)** by two adults. Attach them by using 4 pieces of **Bolt (A)** as shown.

Use **Allen Wrench (C)** to tighten the **Bolts (A)** clockwise until secure.

Repeat the same steps for the remaining 1 piece of **Long Board (2)**.

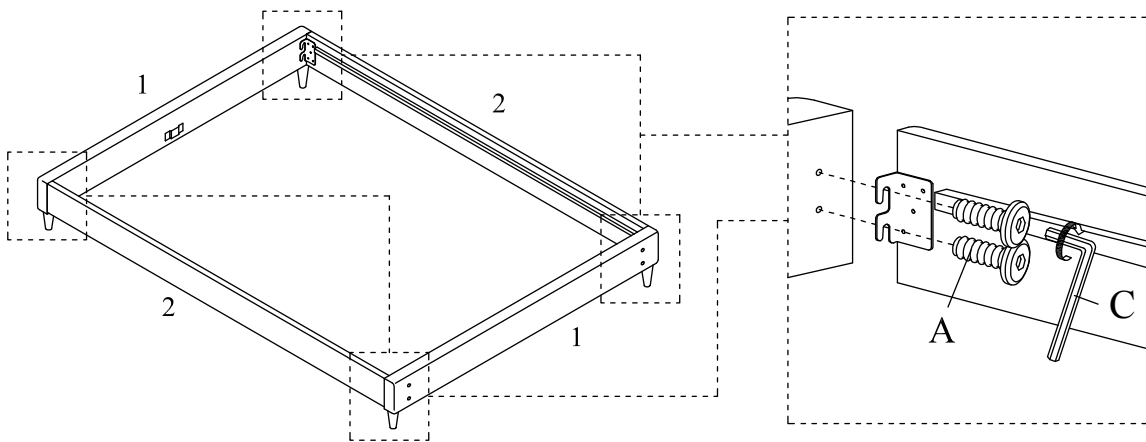

A x 8	C x 1

Hardware & Tool required

BED FRAME

STEP 3

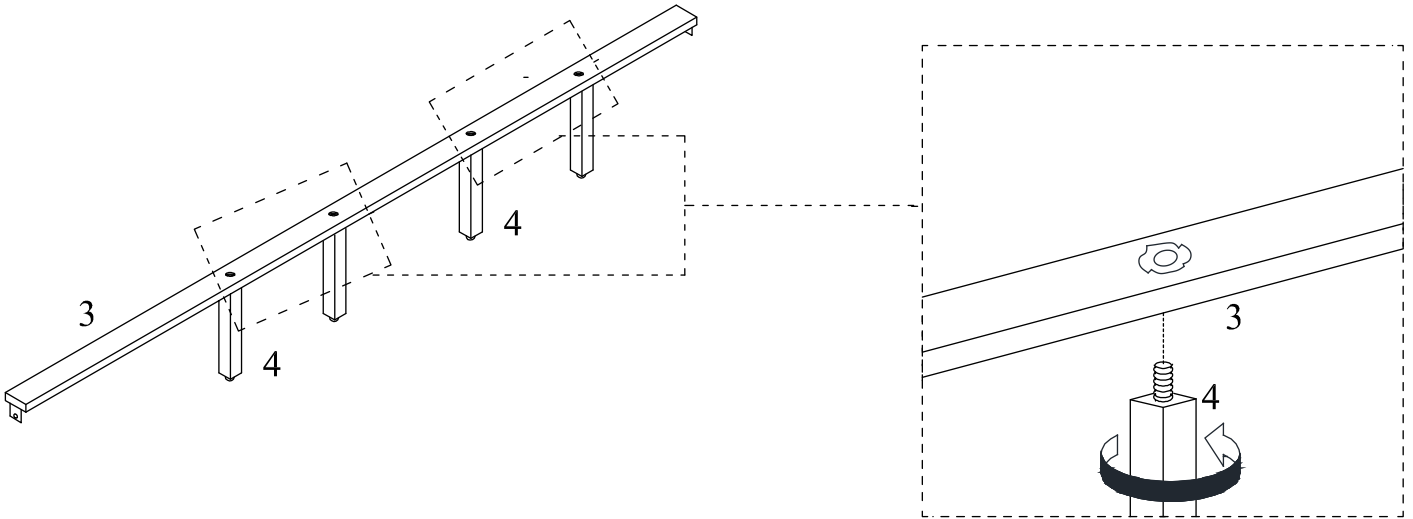

Secure 4 pieces of **Support Leg (4)** to the **Center Rail (3)** with pre-set T-nut as shown. Tighten the **Support leg (4)** clockwise until secure.

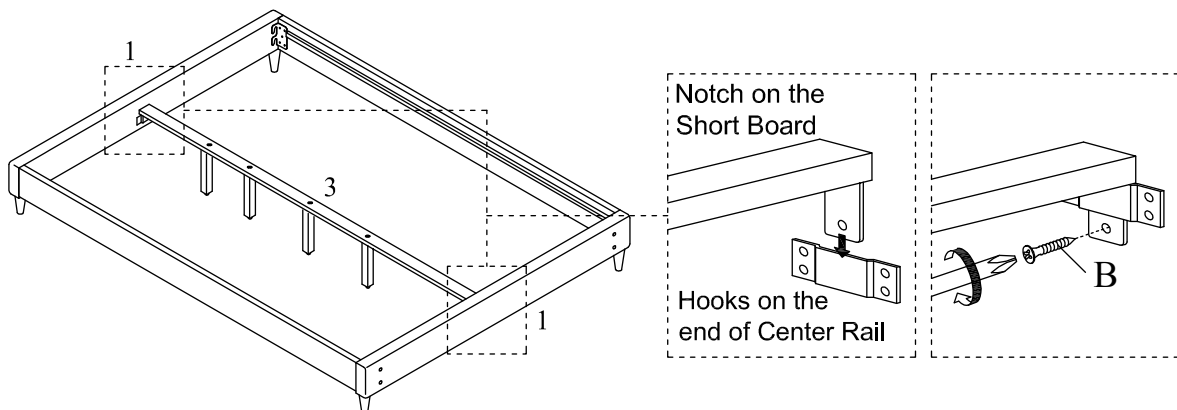

STEP 4

Insert **Center Rail (3)** to the bracket (provided) on **Short Board (1)** and then secure with 1 piece **Screw (B)** per each end. Tighten the **Screw (B)** with Phillips Head Screw Driver (not provided).



	
B x 2	Phillips Head Screw Driver (not provided)

Hardware & Tool required

BED FRAME

STEP 5

Place the **Roll Slats (6)** to the **Long Board (2)** as shown.

Secure 4 pieces of **Roll Slats (6)** which have countersink holes on each end into the **Long Board (2)** by using 8 pieces of **Screw (B)** as shown.

Tighten the **Screws (B)** with Philips Head Screw Driver (not provided).

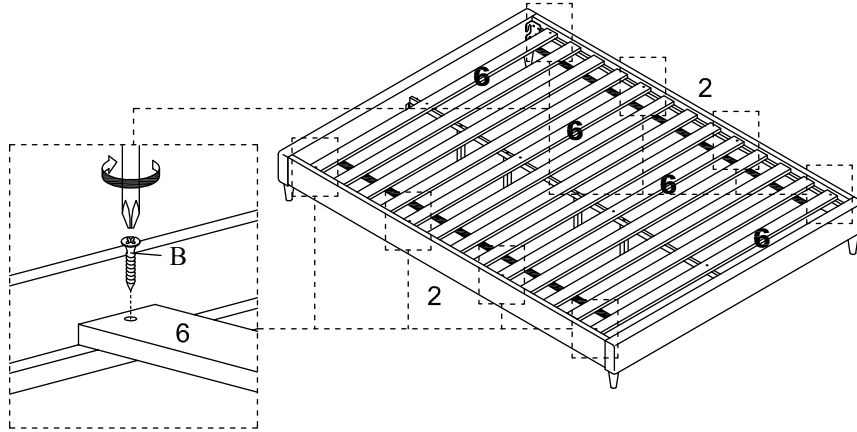

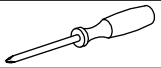
	
B x 8	Phillips Head Screw Driver (not provided)

Hardware & Tool required

STEP 6

Secure 4 pieces of **Screw (B)** into the **Slat (6)** on the top of **Center Rail (3)** as shown.

Tighten the **Screws (B)** with Phillips Head Screw Driver (not provided).

Attention: Please adjust the adjustable glide on the Support Leg (4) once the bed is unlevel.

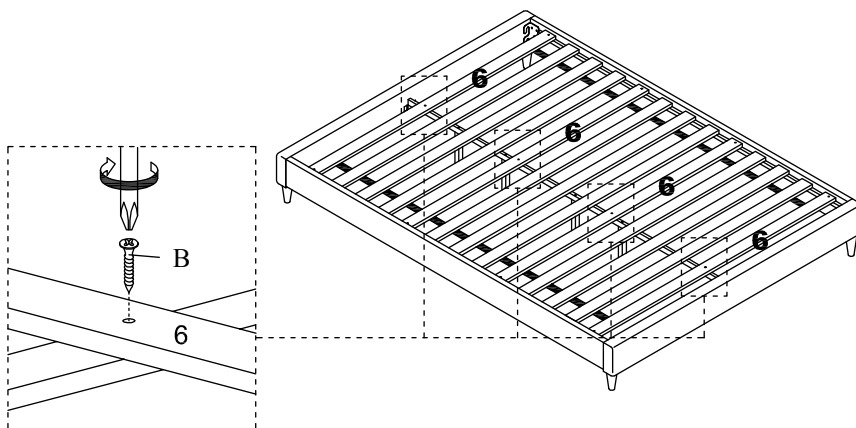

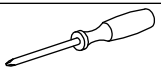
	
B x 4	Phillips Head Screw Driver (not provided)

Hardware & Tool required

Assembly is complete. The bed frame is ready to use now!

NOTE: Hardware may loosen over time. Periodically check that all connections are tight.

ASSEMBLY INSTRUCTIONS

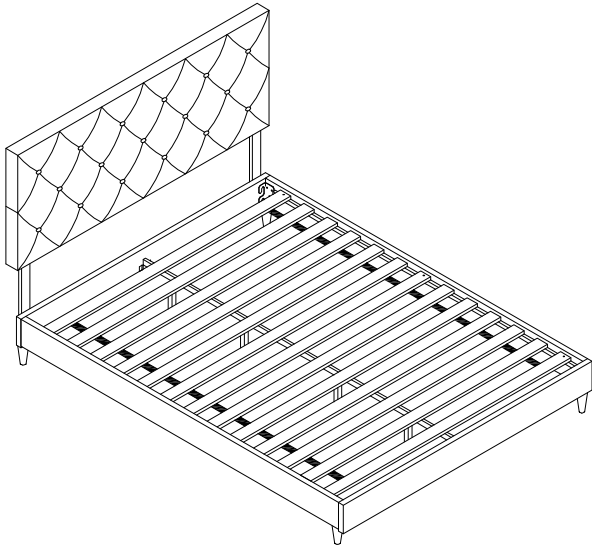

Hardware list:

A		Bolt M6 x 45mm	x4
B		Flat Washer M6	x4
C		Spring Washer M6	x4
D		M4 Allen Key	x1

Reminder: All the hardware packed in the Headboard you bought. Please use only the above hardware from Haedboard Hardware Package to assemble the Bed Frame and Headboard.

Component:

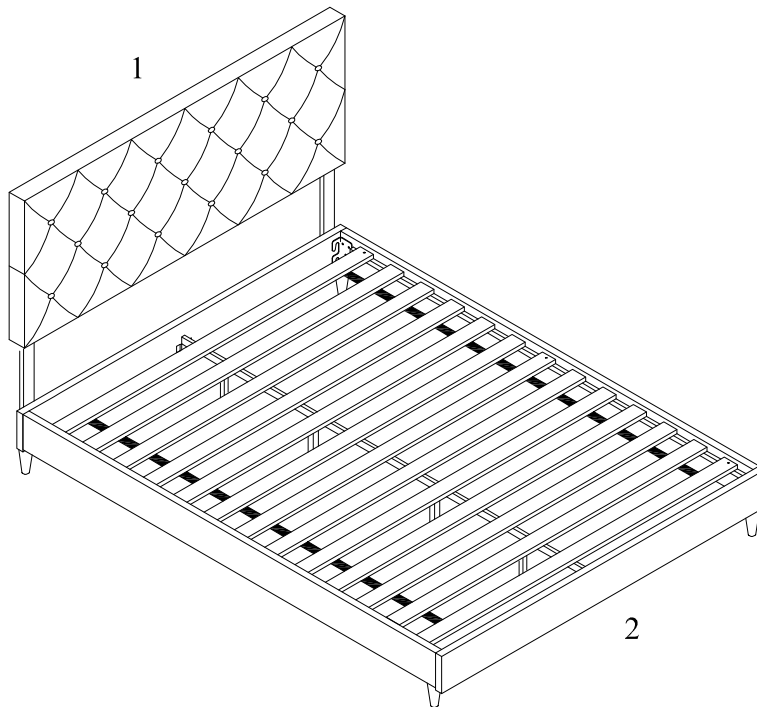

1) Headboard x1

2) Bed Frame x1

(Style may vary)

CONNECTING BED FRAME TO HEADBOARD

STEP 1





Line up the **Bed Frame (2)** board's pre-drilled holes to match those of the **Headboard (1)**.

Secure the **Headboard (1)** to the **Bed Frame (2)** by using 2 pieces of **Bolts (A)** with 2 pieces of **Spring Washer (C)**, 2 pieces of **Washer (B)** into the **Bed Frame (2)**.

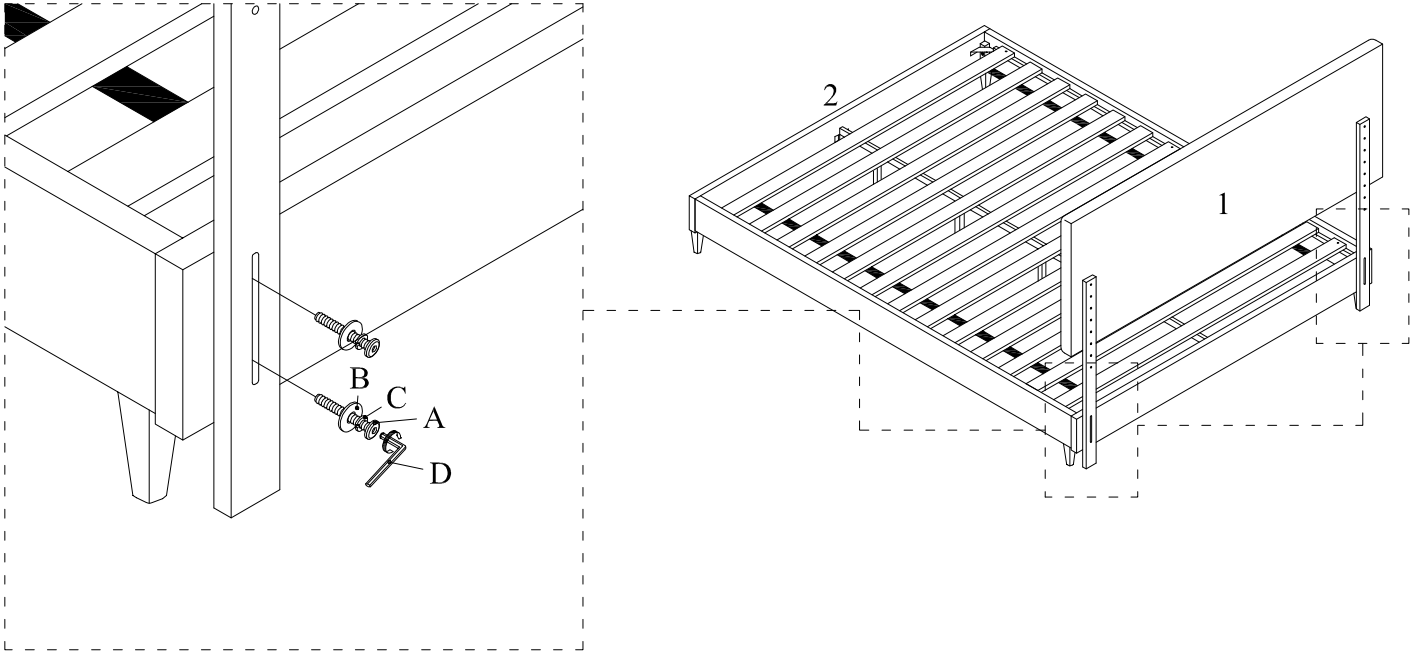
Then tighten the **Bolts (A)** by using **Allen Wrench (D)**.

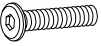
Repeat the same procedure for each bolt and each side of the **Bed Frame (2)**.



			
A x 4	B x 4	C x 4	D x 1

Hardware & Tool required

STEP 2:

Carefully position the assembled bed to the desired location by four adults.

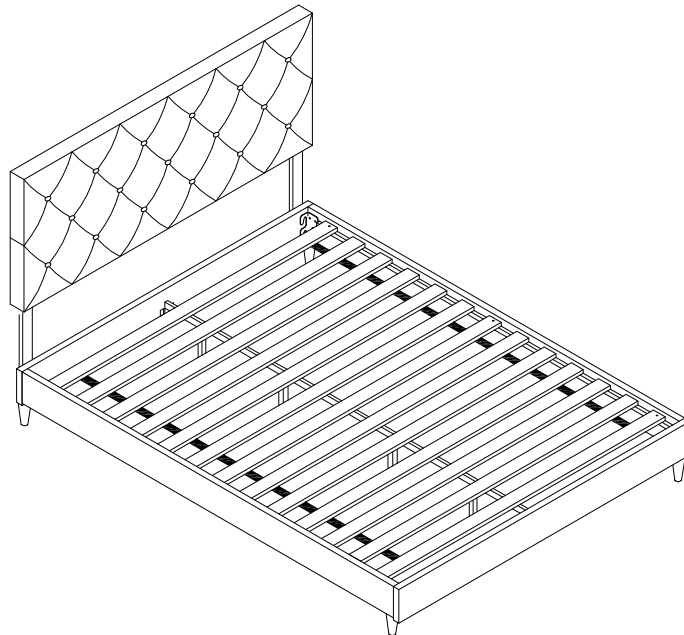

Assembly is complete. The headboard is ready to use now!

NOTE: Hardware may loosen over time. Periodically check that all connections are tight.