

Chair

Assembly Instructions
Instrucciones De Asamblea
Instructions d'Assemblée

PARTS

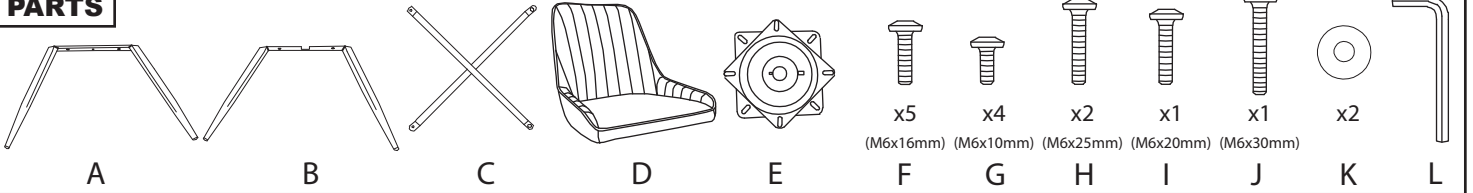

1

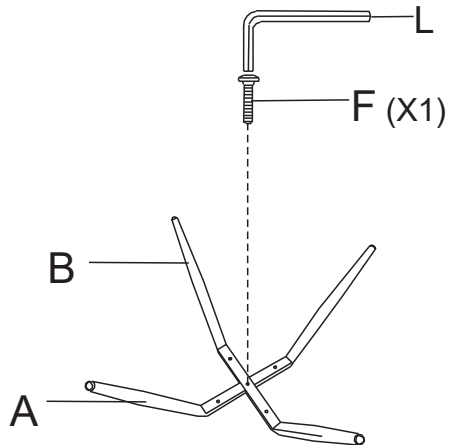

2

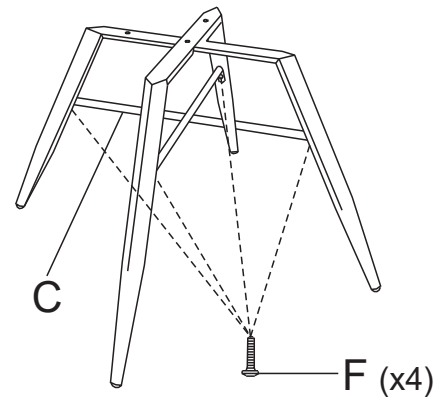

3

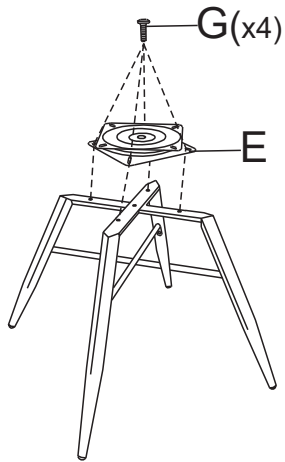

4

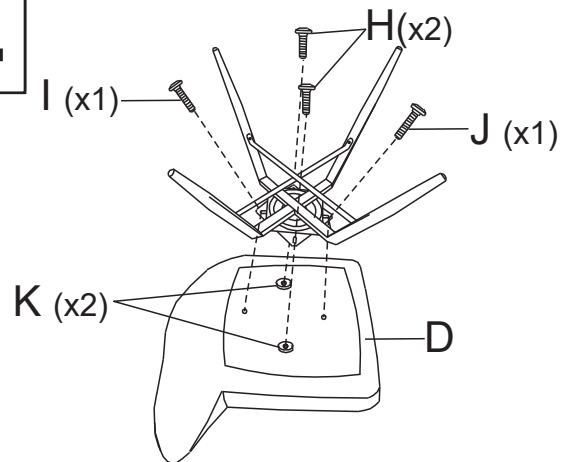

5

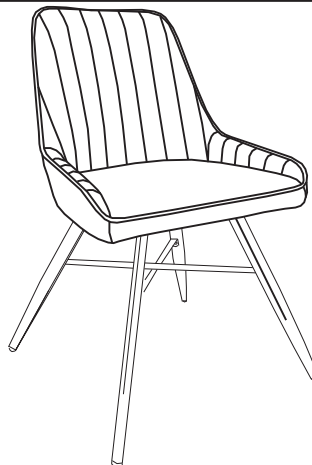

Do not over tighten.
Do not use power tools to assemble.